

Simply a question of  
**better measurement**



## **SCHMIDT® Flow Sensor SS 20.600**

The powerful industrial professional  
for demanding applications invol-  
ving air and gases

Industrial processes

Pneumatic technology





## Flow rate volumes of gases – an important parameter in industrial processes

Measurements to save energy and to assure quality in the production process constitute crucial components in industrial processes. The ability to measure volumetric flow rates and volumetric flow of gases precisely has an important role to play in this. The requirements imposed on the flow rate sensor used for this are demanding: the sensor has to be capable of delivering precise measuring results for different gases, at high positive pressures and across wide ranges of temperature. It also has to be able to do so under the most difficult environmental conditions such as areas at risk of explosion, and in the open air. A further criterion involved in the selection of a suitable sensor is the prevention of maintenance and its attendant high secondary costs. Ease of assembly and reliable measuring values for many years: that is the objective.

## The “true professional” for industrial processes and pneumatic technology

The thermal **SCHMIDT® Flow Sensor SS 20.600** is the robust solution for demanding industrial applications. It can be used for a diverse range of applications, such as compressed air monitoring, gas monitoring on process burners, consumption recording of gases and a great deal more. The sensor records flow speed as well as media temperatures of up to 120°C. It can be used in small tubes from DN 25 upwards and can involve a sensor length of up to 1 metre to measure the volumetric flow rate in large channels and ducts. If the standard version is not sufficient for positive pressures of up to 16 bar, a version rated for up to 40 bar can be selected.

This sensor is incredibly easy to install: screw down the sensor using the threaded dowel, align the sensor in the gas flow and centrally in the pipe, connect up its electrical wiring – and job done!

This sensor operates without any moving parts and employs a measuring principle that eliminates any drift or signs of ageing. This reduces the maintenance required for the sensor – depending on how dirty the medium becomes – to the occasional need for the sensor head to be blown through (air blast) or rinsed in water.

## High gas speeds, special gases or explosion protection? The SS 20.600 can do (almost) everything!

The special chamber head sensor records flow speeds of 0.2 m/s up to 220 m/s. In order to obtain precise measuring results across this very broad speed range, every sensor is individually checked and compared in an elaborate pressurised wind tunnel.

To enable this sensor to be used in different gases, a range of individual versions is available, e. g. for pure oxygen, CO<sub>2</sub>, methane. Of particular interest: Hydrogen will become an important parameter in future, and it can also be measured using the **SS 20.600** (option). For use in other media in potentially explosive atmospheres and environments, the sensor is optionally available in an explosion-protected version (ATEX).

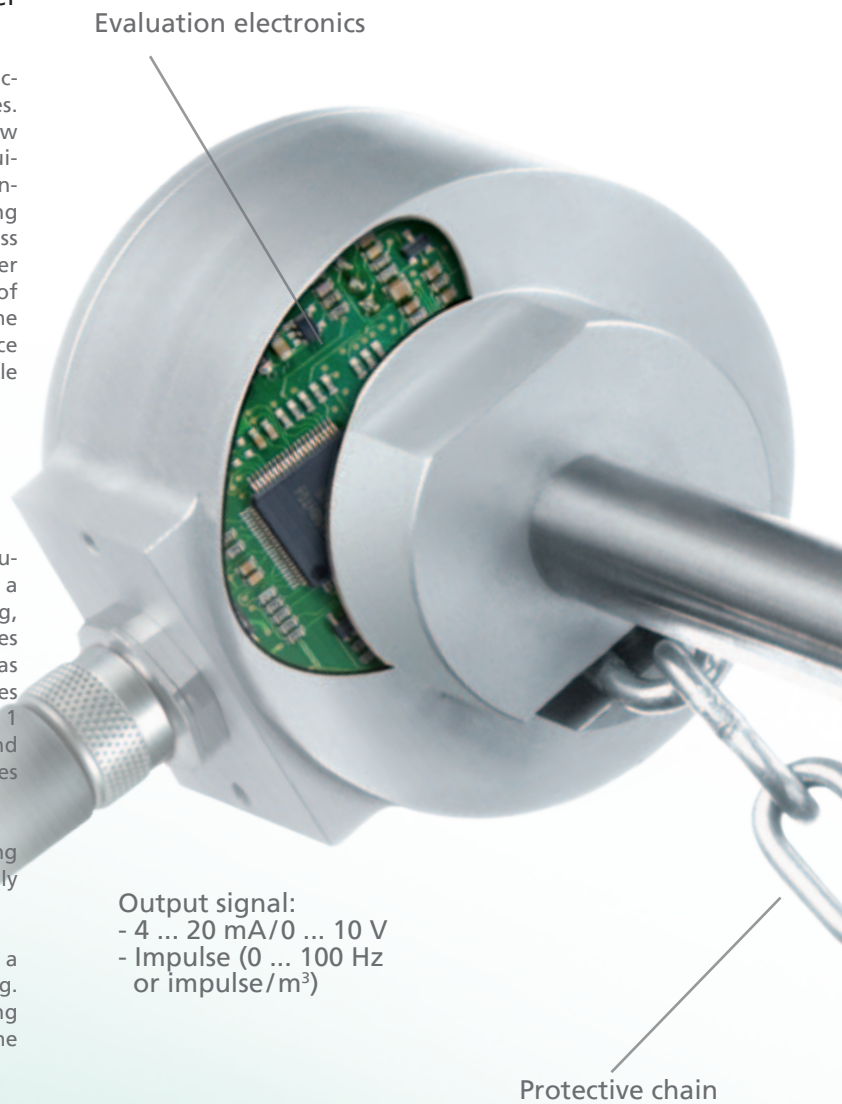

## Practical examples

Branch	Application	The solution with SS 20.600
Industrial processes	Measurement of incoming air to control industrial burners/ incinerators	- High flow rate speeds of up to 220 m/s - Measurement of standard volumetric flow rate independent of pressure and temperature - O <sub>2</sub> version for pure oxygen
	Recording of inert gas volumes (nitrogen)	- Specific versions for gas and gas mixtures - Resistant to positive pressure up to 40 bar
	Feedback control of combustion gas volume (natural gas, methane, ...)	- ATEX version - For pipe diameters from DN 25
	Detection of gas consumption	- Acquisition of the flow rates of "almost zero" to the maximum value (detection gas slippage) - From -40 °C Temperature of medium usable (ATEX version)
Pneumatic technology	Compressed air consumption, compressor control	- Extremely wide measuring ranges for flow rate - Simple signal processing: Impulse per m <sup>3</sup>
	Leakage measurement	- Measurement from 0.2 m/s - Design principle eliminates age-dependent drift
	Monitoring of minimum flow rate	- Monitoring of minimum flow rate - High-precision comparison (1 % precision) - Very fast response speed

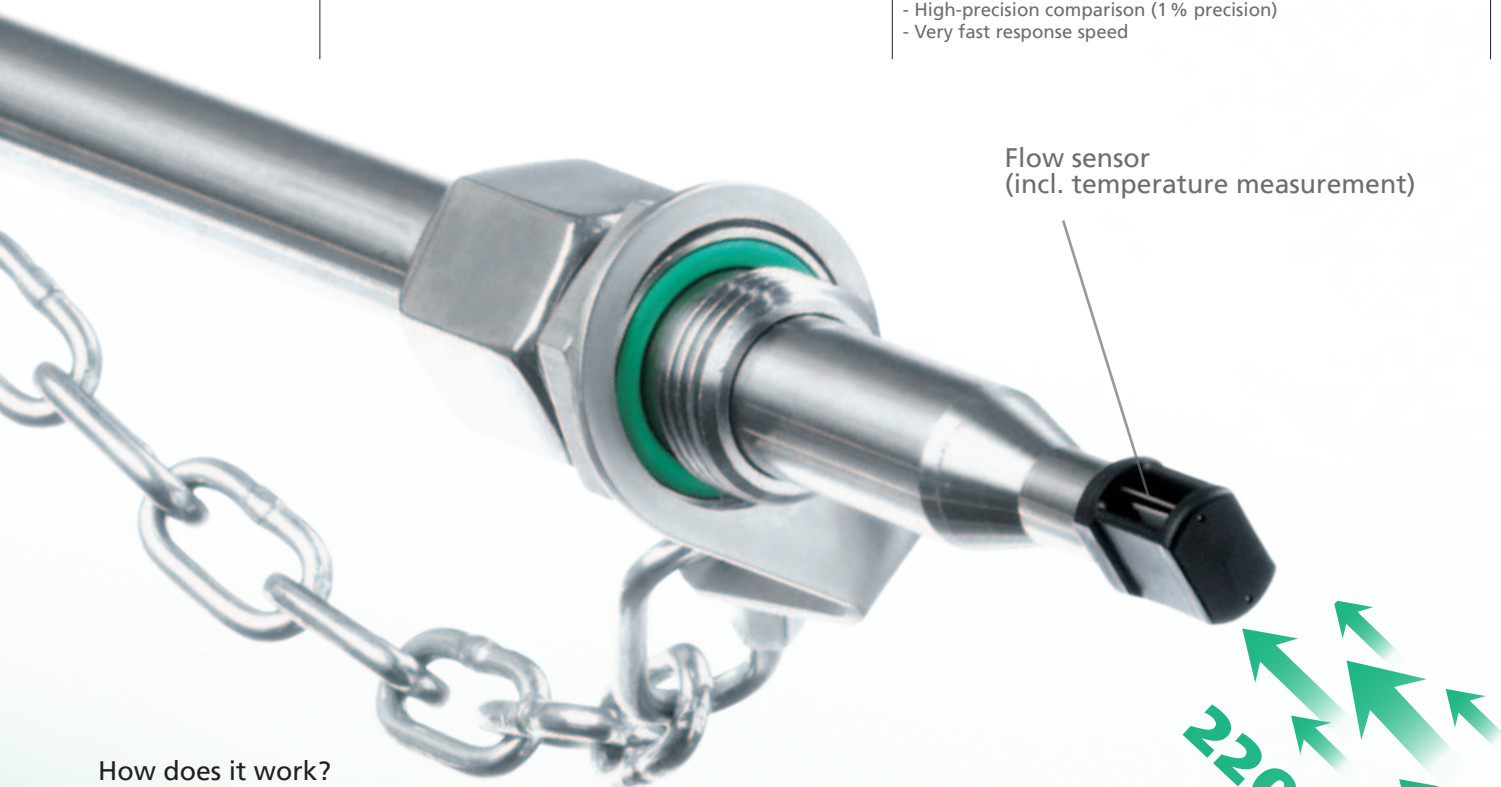

### How does it work?

The flow sensor element is protected, and is positioned in the chamber head in a way that favours unimpeded flow. Sensors for flow rate as well as temperature are arranged on the ceramic sensor element. For protection purposes, sensors are coated with a thin layer of glass. The flow rate sensor is heated to 40 K above the temperature of the medium. The power required to maintain this positive temperature differential ("overtemperature") is an indicator for the flow rate speed that the sensor issues as "normal speed" (linear flow rate/voltage/impulse signal). This is a great advantage of the measuring principle: No additional measurement of the pressure or temperature of the medium is required.

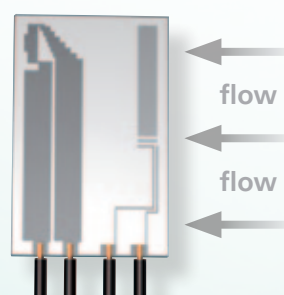



## Individually adapted to suit every application – you have the choice!

For optimum installation in the various different pipe diameters, 4 standard sensor lengths as well as special lengths of 120 to 1000 mm can be selected. An remote version is available for difficult installation conditions. The probe length itself and the cable length between sensor and housing can be selected.

To enable the sensor to be adapted to suit prevailing flow rate conditions, 6 standard measuring ranges are available, extending up to 220 m/s. The volumetric flow rate is the product of the flow rate speed, multiplied by the pipe cross-sectional surface area and a profile factor. However, customer-specific measuring ranges can also be supplied in increments of 0.1 m/s. The advantage of this is that a desired maximum volumetric flow rate determines the measuring range of the sensor as a function of pipe diameter. Example: Maximum volumetric flow rate of 450 m<sup>3</sup>/hr with a pipe diameter of DN 65 yields a maximum flow rate measuring range for the sensor of 48.1 m/s (= 20 mA or 10 V). For the purposes of simple conversion, the homepage features a flow rate calculator that also determines the profile factor, which is dependent on the pipe cross section.

For evaluation systems with impulse inputs, the **SS 20.600** offers an additional impulse output for the flow rate signal. Here, there is a standard measuring range of 0 ... 100 Hz or, if the pipe diameter is indicated, the choice of 1 impulse per m<sup>3</sup> as a customer-specific output.

## Measure other gas media too? Absolutely!

More often than not, the medium being measured is not air, but instead comprises other gases or gas mixtures. For these specialist applications, gas-specific versions of the **SS 20.600** can be supplied. With these versions, the sensor has a specific correction – based on a comparison check in air – programmed in. These correction factors were established individually for each gas on genuine gas channels. For gas mixtures, each correction is calculated on the basis of a individual customer specification. For media with an oxygen content of > 21 % of volume all components in contact with the media must be cleaned to remove greases, oils and/or other combustible constituent elements. A specific grease-free and O<sub>2</sub> > 21 % variant provides the required safety for this application.

## Accuracy – in black & white

As an option, the **SS 20.600** can be supplied with a high precision adjustmant for air that can also be used for pure oxygen and nitrogen. This measurement is carried out in house of **SCHMIDT Technology**. The high levels of precision and reproducibility are documented in an ISO calibration certificate (attached). This calibration can be renewed to suit user definitions.

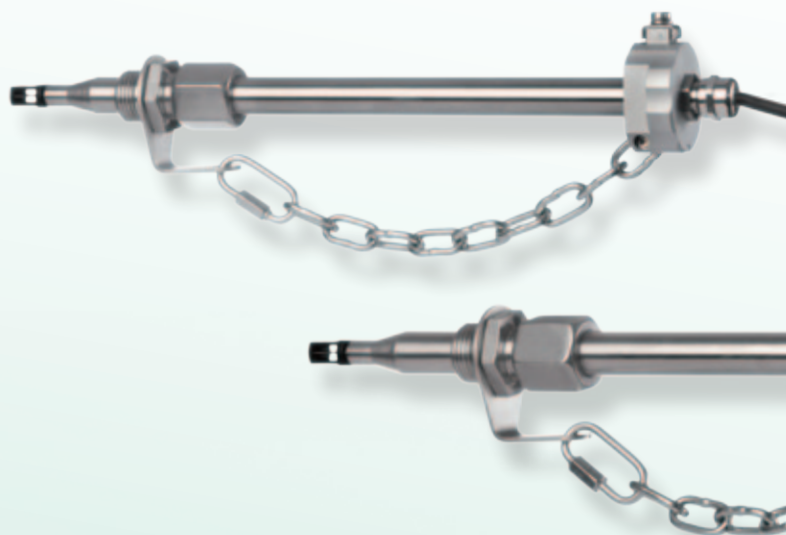

## Everything in view

The LED display is dual function. In "normal" operation the 4 x LED's illuminate steady green in sequence. In "fault" condition reportable faults are indicated by red flashing LED's. The instrument will output V and mA and change-over is automatic.

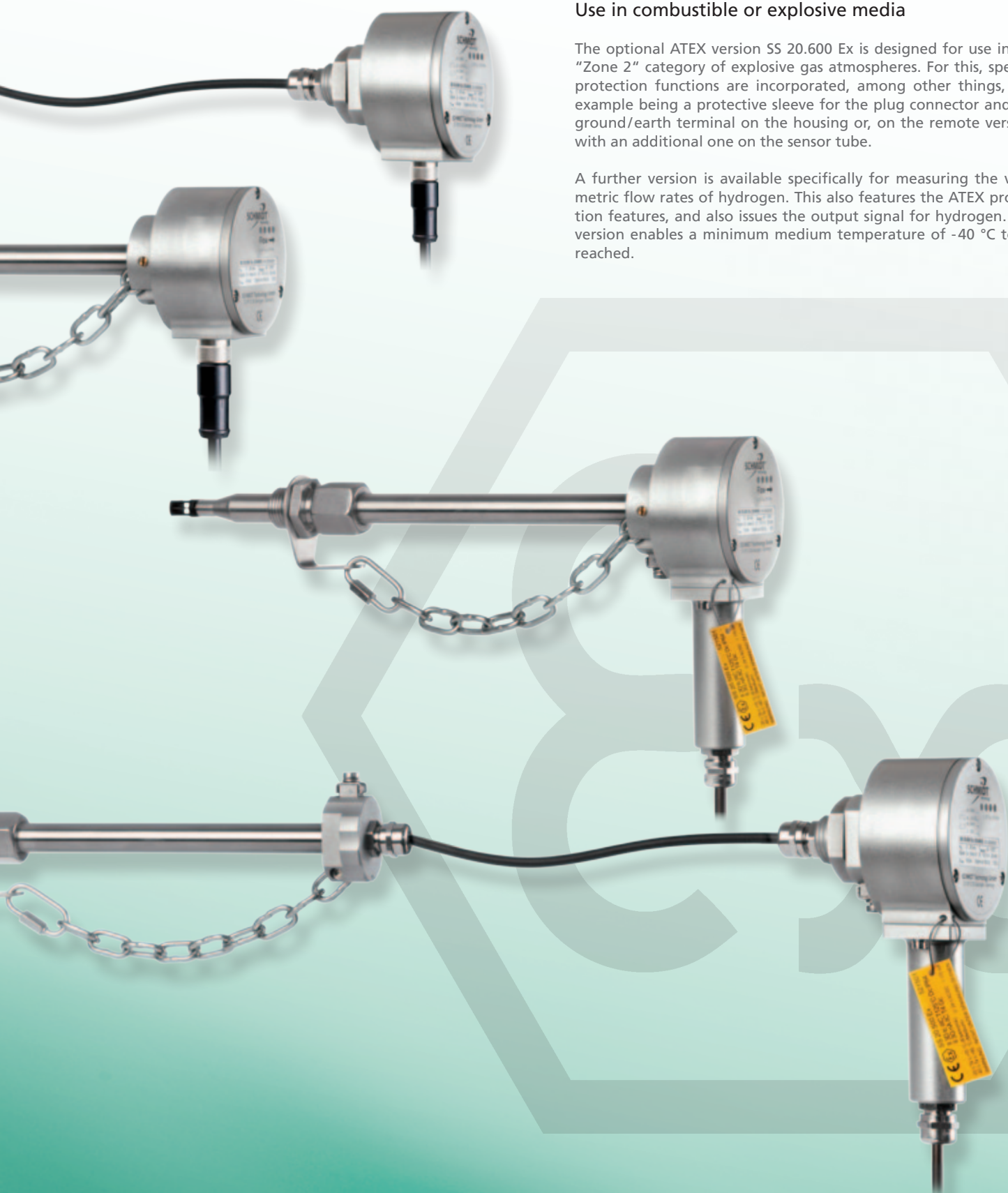

### Use in combustible or explosive media

The optional ATEX version SS 20.600 Ex is designed for use in the "Zone 2" category of explosive gas atmospheres. For this, specific protection functions are incorporated, among other things, one example being a protective sleeve for the plug connector and the ground/earth terminal on the housing or, on the remote version, with an additional one on the sensor tube.

A further version is available specifically for measuring the volumetric flow rates of hydrogen. This also features the ATEX protection features, and also issues the output signal for hydrogen. This version enables a minimum medium temperature of  $-40\text{ }^{\circ}\text{C}$  to be reached.

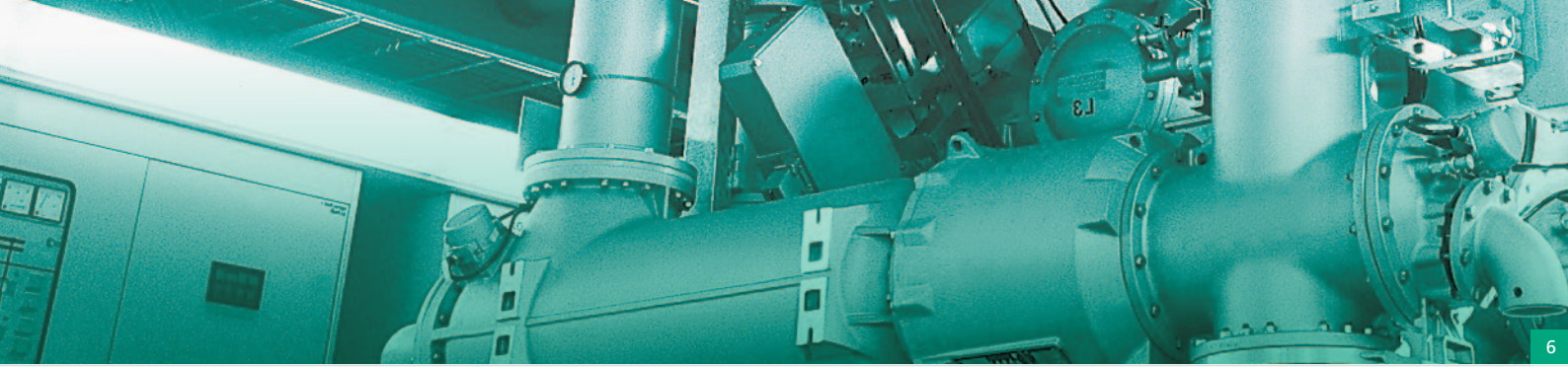

### Dimensions of the basic sensor

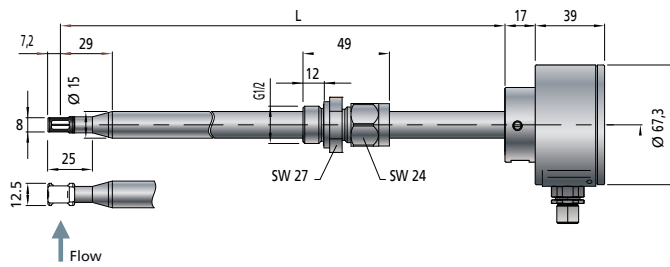

### ATEX version SS 20.600 Ex (optional)

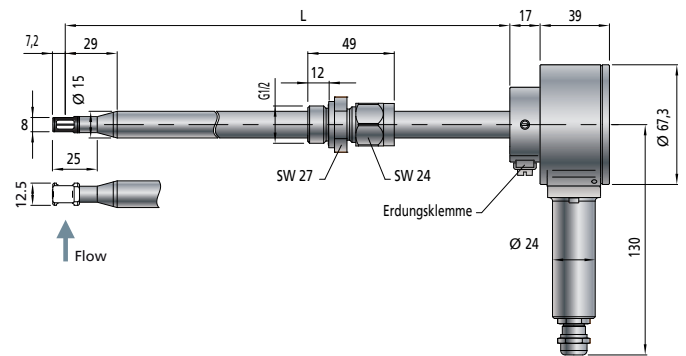

### Remote sensor including wall mounting bracket

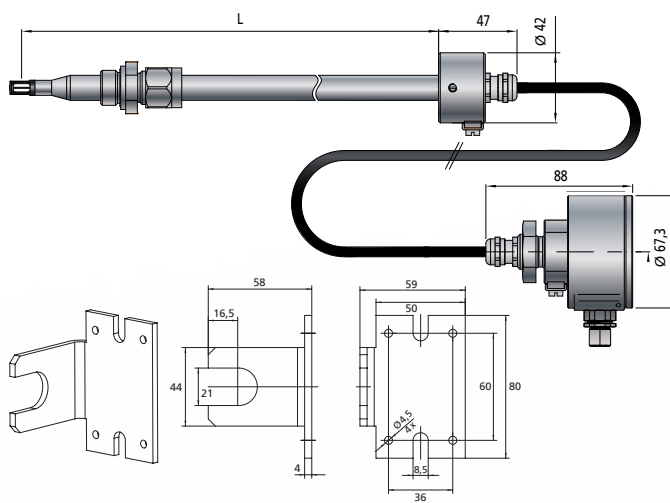

### Remote sensor, ATEX version (optional) including wall mounting bracket

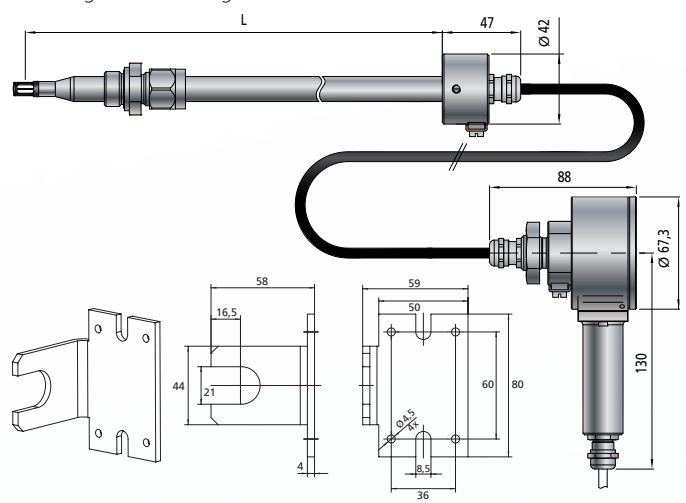

### Mounting instructions

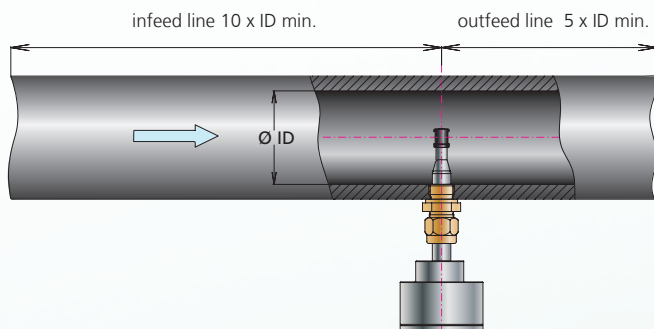

### Mounting parameters

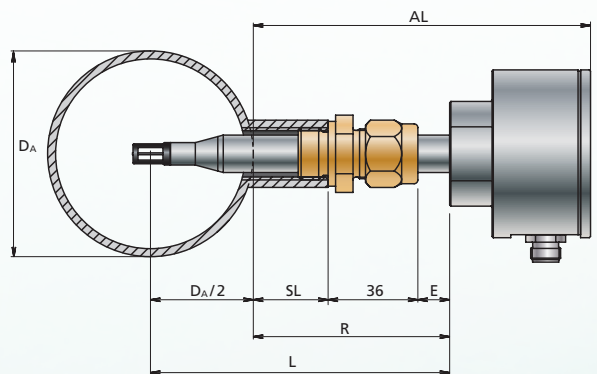

- $D_A$  = Outer diameter of tube
- SL = Length of welded journals
- E = Adjustable length of sensor tube
- AL = Extended length of compact sensor
- R = Reference length
- L = Length of sensor
- All dimensions in mm

## Technical Data

Measuring data	
Measurement values $w_N$	Standard flow velocity $w_N$ normalized to 20 °C and 1.013,25 hPa
Measuring fluid	Air, nitrogen; optional: Natural gas, biogas, CO <sub>2</sub> , hydrogen and specialty gases and gas mixtures
Measuring range flow $w_N$	0 ... 10/20/60/90/140/220 m/s; optional: customised measuring ranges in 0,1 m/s-steps
Lower detection limit $w_N$	0.2 m/s
Measuring Range $T_M$	-20 ... +120 °C; SS 20.600 EX: -40 ... +120 °C
Accuracy	
Standard $w_N$	±3 % of measurement + (0.4 % MBE; min. 0,08 m/s)*
High precision $w_N$ (optional, for Air, nitrogen, oxygen only)	±1 % of measurement + (0.4 % MBE; min. 0,08 m/s)*
Repeatability $w_N$	±1 % of measurement
Response time $t_{90} w_N$	1 s (jump from 0 to 5 m/s air)
Temperature gradient $w_N$	< 8 K/min bei $w_N = 5$ m/s
Measurement accuracy temperature $T_M$	±1 K (10 ... 30 °C); ±2 K remaining measuring range (bei $w_N > 5$ m/s)
Operating temperature	
Sensor	-20 ... +120 °C; SS 20.600 EX: -40 ... +120 °C
Electronics	-20 ... +70 °C
Storage temperature	-20 ... +85 °C
Material	
Housing	Aluminium, anodized
Sensor tube, screw connection	Stainless steel 1.4571
Sensor head	Board element (glass-passivized), PPO/PA
Protective sleeve	Aluminium, anodized
Sensor cable (on offset sensor)	PUR mantle, halogen-free, UL
General Data	
Medium, environment	non-condensing (up to 95 % rF)
Maximum pressure	16 or 40 bar
Display	4 x Duo LEDs green / red / orange
Supply voltage	24 VDC ±20 %
Current intake	approx. 50 mA (without impulse outputs); max. 250 mA
Analogue outputs for temperature and flow rate Auto U/I	0 ... 10 V / 4 ... 20 mA (protected against short circuits) Voltage output: > 550 Ω Current output: < 500 Ω Hysteresis: 50 Ω
Impulse outputs	Frequency 0 ... 100 Hz, as an option: 1 Impuls/1 m <sup>3</sup> ; 1 Impuls/0.1 m <sup>3</sup> /h; 1 impulse/0.01 m <sup>3</sup> /hr (max. 100 Hz) 1. Highside driver to supply voltage (not electrically isolated) 2. Semiconductor relay (electr. isolated); max. 30 V/50 mA High level: > supply voltage - 3 V Short circuit current limitation: 200 mA
Electrical connection	M 12 plug connection, screwed, 8-pin
Maximum line length	Voltage signal: 15 m, current signal/Impulse: 100 m
Mounting position	any, (with vertical gravity flow: lower limit of measuring range 2 m/s at 16 bar)
Installation tolerance	±3° to the flow direction
Minimum immersion depth	20 mm
Type/class of protection	IP 65 (housing), IP 67 (sensor) / III or PELV
ATEX category	II 3G Ex nA ic IIC T4 Gc
Sensor length	Compact sensor: 120 / 250 / 400 / 600 mm; special lengths of sensor from 120 to 1000 mm
Weight	approx. 500 g max. (without connection cables)

\* under reference conditions, related to comparative reference

## Accessories

### SCHMIDT® Probe ball valve

(see separate brochure)

A choice of probe ball valves are available to facilitate fast removal and installation in 1" to 2" pipework. Advantage: even while the system is under pressure, it is no problem to install or remove the sensor.

A straight-run ball valve is available for larger diameters of pipework.



### SCHMIDT® LED measured value display

(see separate brochure)

For display purposes directly on location, an LED unit is available to display measuring values.

The advantages:

- Display in m/s or m<sup>3</sup>/h
- Programmable output signal
- Two programmable relay outputs
- Power supply: 85 – 250 V AC or 24 V DC
- Power supply to the connected sensor
- Separate version with "sum" function
- Detection of direction of flow involves the use of two SS 20.600 units arranged at 180° to one another

### Extended connection options with field bus modules

(available from Q4, 2012)

As an option, the following variants are available for integrating the SS 20.600 into existing BUS systems:

- DeviceNet
- ProfiBUS DP
- others on request

The BUS modules are housed in a rugged auxiliary housing. The standard outputs are available in addition to the BUS signal.

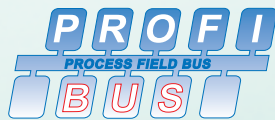
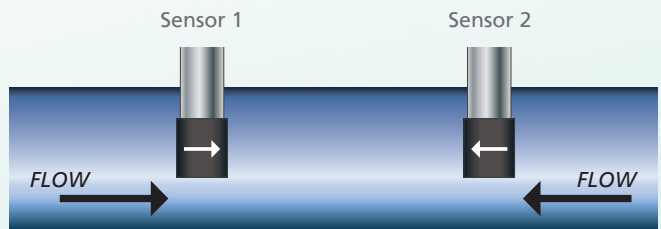

Shielded connection cable available in various lengths



Coupler socket with screw type terminals  
Type no. 524 929



Welding steel sleeves Type no. 524 916  
or stainless steel Type no. 524 882

## Order information for the SCHMIDT® Flow Sensor SS 20.600

	Description	Article number									
		524 600	A	B	C	D	E	F	G	H	PP
Basic sensor	SCHMIDT® Flow Sensor SS 20.600; output signal 4 ... 20 mA and 0 ... 10 V; impulse output, incl. pressure-tight stainless steel compression fitting										
	<b>Optionen</b>										
Mechanical type	Probe length 120 mm		1								
	Probe length 250 mm		2								
	Probe length 400 mm		3								
	Probe length 600 mm		4								
	Special lengths (> 120 mm to 1000 mm): Length: ____ mm		8								
	Offset sensor (Length: 120/250/400/600 mm) and cable (Length: ____ m (max. 10 m)), incl. wall mounting bracket		9								
	Pressure-tight compression fitting, stainless steel G ½			1							
	Pressure-tight compression fitting, stainless steel R ½ (PT)			2							
Measuring ranges <sup>1</sup> and calibration	Measuring range 0 ... 10 m/s				1						
	Measuring range 0 ... 20 m/s				2						
	Measuring range 0 ... 60 m/s				3						
	Measuring range 0 ... 90 m/s				4						
	Measuring range 0 ... 140 m/s				5						
	Measuring range 0 ... 220 m/s				6						
	Special measuring range (10 ... 220 m/s) in 0,1 m/s-steps: ____, ____ m/s				9						
	Standard adjustment					1					
	High-precision adjustment check incl. ISO calibration certificate					2					
	Standard adjustment check with conversion factor for methane <sup>2)</sup>					3					
	Standard adjustment check with conversion factor for biogas (60% methane, 40% CO <sub>2</sub> ) <sup>2)</sup>					4					
	Standard adjustment check with conversion factor for CO <sub>2</sub> <sup>2)</sup>					5					
	Standard adjustment check with conversion factor for H <sub>2</sub> <sup>2)</sup>					6					
Standard adjustment check with conversion factor for special gases and mixtures <sup>2)</sup>					9						
Impulse output	Standard 100 Hz (= limit value of measuring range w <sub>N</sub> )					1					
	1 impulse / 1 m <sup>3</sup> for pipe diameter (round) ____ mm					2					
	1 impulse/0.1 m <sup>3</sup> for pipe diameter (round) ____ mm					3					
	1 impulse/0.01 m <sup>3</sup> for pipe diameter (round) ____ mm					4					
Additional outputs	Without communications module							1			
	Communications modules for Modbus, DeviceNet, ProfiBUS (from Q4, 2012)							*			
Protection version ATEX	Without ATEX version (SS 20.600)								1		
	ATEX version (SS 20.600 EX) <sup>2)</sup>								2		
Protection version, grease-free; O <sub>2</sub>	Standard application									1	
	Grease-free and for O <sub>2</sub> > 21% <sup>2)</sup>									2	
Overpressure	Operating pressure DD: 00 (atmospheric) ... 16 (16 bar positive pressure)									00 ... 16	
	Operating pressure DD: 17 ... 40 (40 bar positive pressure) <sup>2)</sup>									17 ... 40	

\* On request

<sup>1)</sup> To select the appropriate measurement range use our **flow computer** on [www.schmidttechnology.de](http://www.schmidttechnology.de)

<sup>2)</sup> Not in combination with the option "special lengths" available

## Order information SCHMIDT<sup>®</sup> Flow Sensor SS 20.600

	Description	Article number
Accessories	Connecting cable, 8 pole, cable length 5 m, with coupling socket and open cable end sleeves	524 921
	Connecting cable, 8 pole, length can be selected, with cable end sleeves, free of halogen	524 942
	Coupler socket, 8 pole, with screw type terminals, for ø 6 cables ... 8 mm	524 929
	G½ steel welding sleeve, acc. to EN 10241, 5 pieces	524 916
	1.4571 G½ stainless steel welding sleeve, acc. to EN 10241, 2 pieces	524 882
	Power supply unit 24 VDC	535 282
	SCHMIDT <sup>®</sup> LED display MD 10.010; in wall housing to show the volume flow and flow velocity, 85 ... 250 V AC and sensor supply	527 320
	SCHMIDT <sup>®</sup> LED display MD 10.010; similar to 527 320, but with 24 V DC voltage supply	528 240
	SCHMIDT <sup>®</sup> LED display MD 10.015; in wall-mounted housing, similar to 527 320 but with additional sum function and second measuring input	527 330
	SCHMIDT <sup>®</sup> LED display MD 10.015; similar to 527 330, but with 24 V DC voltage supply	528 250
	Assembly kit for pipe assembly, suitable for MD 10.010 / 10.015, including pipe clamps and collar for adjustment to the pipe diameter	531 394
	Probe ball valve 1" internal thread, connection to flow sensor: ½" internal thread incl. plug and chain	530 940
	Probe ball valve 1¼" internal thread, connection to flow sensor: ½" internal thread incl. plug and chain	530 941
	Probe ball valve 1½" internal thread, connection to flow sensor: ½" internal thread incl. plug and chain	530 942
	Probe ball valve 2" internal thread, connection to flow sensor: ½" internal thread incl. plug and chain	530 943
	Full-length probe ball valve ¾" internal thread, with threaded adapter for ½" full-length screw connection ¾"	532 355
	Welded socket, steel, external thread ¾", 5 pieces	531 200
	Welded socket, stainless steel, external thread ¾", 2 pieces	531 201

### SCHMIDT Technology GmbH

Feldbergstraße 1  
78112 St. Georgen/Germany

Phone +49 77 24/8990  
Fax +49 24/899101

sensors@schmidttechnology.de  
www.schmidttechnology.de