

Simply a question of
better measurement



**SCHMIDT[®] LED Measured Value Display
MD 10.010
Instructions for Use**

Table of Contents

1	Important Information	3
2	Application range	4
3	Mounting instructions.....	4
4	Electrical connection.....	6
5	Signalizations	8
6	Startup	9
7	Service information.....	16
8	Technical data	17
9	EC Declaration of conformity.....	18

Legal note:

Copyright 2011 **SCHMIDT Technology**

All rights reserved

Version 531010.02

Subject to modifications

1 Important Information

These instructions for use contain all the required information for a fast commissioning and a safe operation of **SCHMIDT**[®] LED measured value displays:

- These instructions for use must be read completely and observed carefully, before putting the unit into operation.
- Any claims under the manufacturer's liability for damage resulting from non-observance or non-compliance with these instructions will become void.
- Tampering with the device in any way whatsoever - with the exception of the designated use and the operations described in these instructions for use - will forfeit any warranty and exclude any liability.
- The unit is designed exclusively for the use described below (refer to *chapter 2*). In particular, it is not designed for direct or indirect personal protection.
- **SCHMIDT Technology** cannot give any warranty as to its suitability for a certain purpose and cannot be held liable for accidental or sequential damage in connection with the delivery, performance or use of this unit.

Symbols used in this manual

The symbols used in this manual are explained in the following section.



Danger warnings and safety instructions - please read them!

Non-observance of these instructions may lead to injury of the personnel or malfunction of the device.

General note

All dimensions are indicated in mm.

2 Application range

The **SCHMIDT**[®] LED measured value display MD 10.010 (material numbers: 527320 and 528240) is used to display measured values which are transmitted by a sensor in form of an analog signal (current or voltage). The supply voltage of the sensor can be provided by the LED measured value display. Switching points for two alarm outputs can be derived from the input signal. The galvanically isolated analog output is able to send the modified input signal.

The **SCHMIDT**[®] LED measured value display MD 10.010 can also be used for **SCHMIDT**[®] flow sensors as well as for other sensors (e.g. pressure, temperature, humidity) which are equipped with standard analog outputs.

The **SCHMIDT**[®] LED measured value display MD 10.010 is designed for the use inside closed rooms and is not suitable for outdoor use (risk of condensation on electronic parts). Moreover, the uses in safety relevant applications are not allowed.

3 Mounting instructions

Dimensions

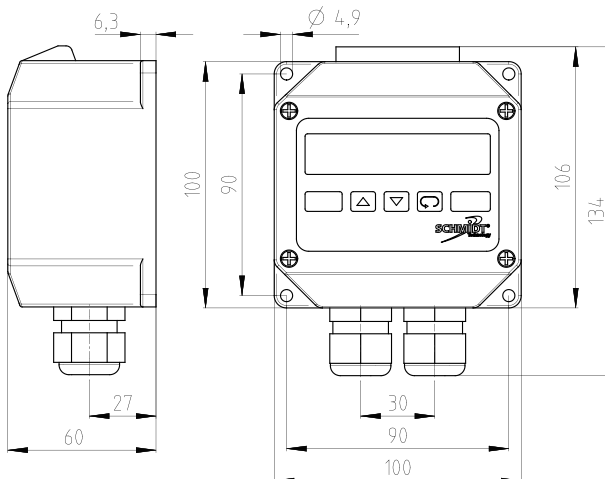

Figure 1: Dimensions of the housing

Wall mounting

The measured value display is installed on the wall by means of four screws. The distances of the holes are indicated in Figure 1. Please make sure that there is enough space to open the upper part of the housing in order to establish the electrical connection.

Lateral through-bolt joints

After installation of the measured value display, the through bolt joints included in the delivery can be mounted instead of the dummy plugs.

Opening the housing

To establish the electrical connection, the housing must be opened. For this, loosen the four screws on the housing. To facilitate the opening of the housing, loosen the screws, pull them to the top as far as possible and fix them in the cover by turning them to the left.



During electrical installation ensure that no voltage is applied and inadvertent activation of the operating voltage is not possible.

As a result of the design, the components susceptible to ESD inside the open housing are not protected against unintentional contact. The terminals are resistant to ESD in contrast to the other parts of the electronic system (e.g. cover board with configuration jumper). In order to avoid damages to the electronic parts, make sure that no ESD spark can be transmitted to the electronic parts (e.g. electronic discharge of the operating person on a grounded object before opening the housing).



Take respective protective measures to avoid damages due to electrostatic discharge (ESD).

4 Electrical connection



During electrical installation ensure that no voltage is applied and inadvertent activation is not possible.



The electrical connection must be carried out by trained and qualified personnel.

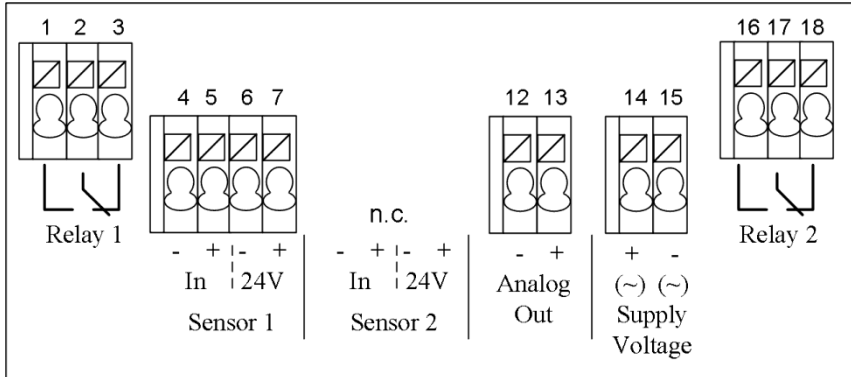

Figure 2: Terminals

Terminal	Designation	Function
1 - 3	Relay 1	Alarm output 1 (max. 250 VAC / 5 A)
4	Sensor 1 In-	GND
5	Sensor 1 In+	Analog input 1 (jumper Ch.1 for configuration of current or voltage input)
6	Sensor 1 24V -	GND
7	Sensor 1 24V+	Supply voltage of the sensor (24 V \pm 15 %, max. 160mA)
12	Analog Out -	AGND (galvanically isolated from GND)
13	Analog Out+	Analog output
14 - 15	Supply Voltage	Operating voltage according to the version: DC: (10) 24V, (11) GND AC: (10) , (11)
16 - 18	Relay 2	Alarm output 2 (max. 250 VAC / 5 A)

Table 1: Connection

Operating voltage

For the proper operation, the measured value display requires DC voltage with a nominal value of 24 V with permitted tolerance of $\pm 20\%$ (material No. 527320) or an AC voltage between 90 and 230 VAC (material No. 528240).



Only operate the measured value display in the defined operating voltage range and with the respective voltage type.

Undervoltage may result in malfunction, overvoltage may lead to irreversible damages.

Analog input

The jumper in the housing cover can be used to switch the analog input of the display between current and voltage signal.

If the bridge is placed on the left contact pins (*Voltage*) a voltage signal is expected. If the plug connects the right pair of pins (*Current*), a current signal must be active.

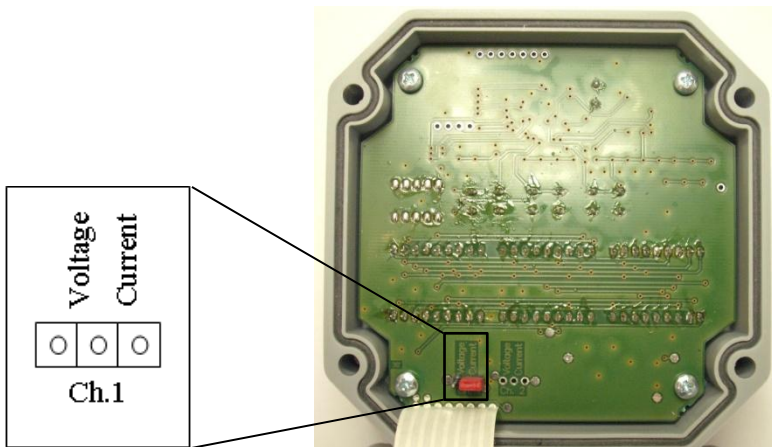

Figure 3: Jumper current/voltage input in the housing cover

Analog output

The analog output of the MD 10.010 is galvanically isolated from the energy supply and the sensor. Depending on the value of the measuring resistance R_L (switching threshold: $R_L = 500 \Omega$), the signal electronics switches automatically between the operation as voltage interface (U) or current interface (I). In the configuration menu, a beginning of the measuring range without offset (0 mA or 0 V) or with offset (signal transmitting zero point: 2 V or 4 mA) can be selected.

5 Signalizations

Display

Display	State
Initialization	Initialization of measured value display. Duration approx. 5s after having switched on the supply voltage
Lock	Key lock activated
Error	Error message of the sensor
Display flashes	Area that can be displayed is exceeded or not reached

Table 2

Analog output

If the connected sensor indicates an error, the error is also transmitted to the analog output:

- Output area without offset: 0 ... 20 mA and ... 10 V
In the current mode the interface outputs 0 mA.
In the voltage mode the output switches to 0 V.
- Output area with offset: 4 ... 20 mA and 2 ... 10 V
In the current mode the interface outputs 2 mA.
In the voltage mode the output switches to 1 V.

6 Startup

Before switching on the **SCHMIDT**[®] measured value display MD 10.010, check whether the device is installed correctly, both mechanically and electrically.

If the measured value display is in the correct operational state, the display is ready for operation approx. 5 s after switching on the supply voltage.

Operating and display elements

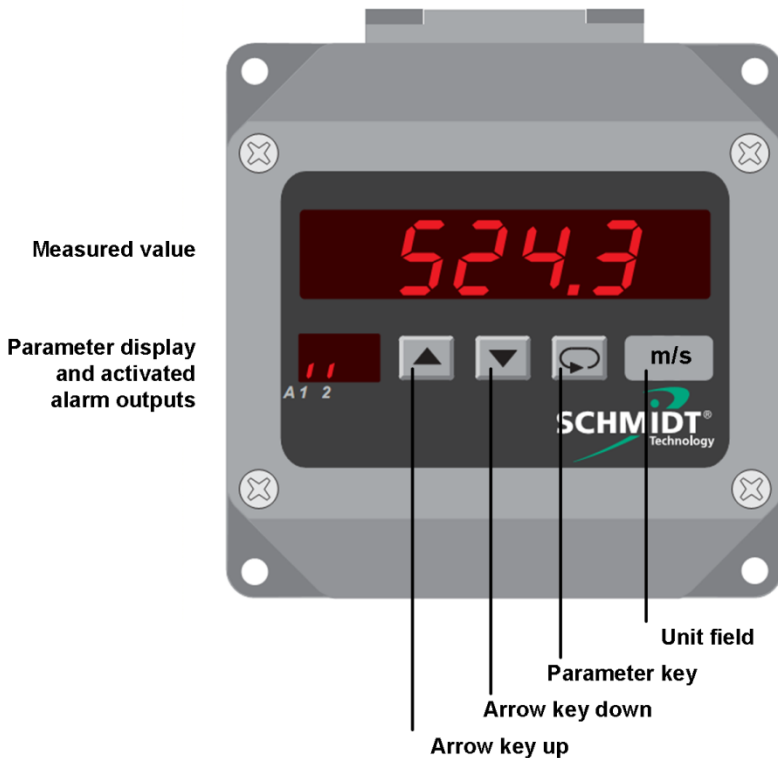

Figure 4: Operating and display elements

General

After switching on the supply voltage, the device is ready for operation as a standard display device and indicates the current measured value and the states of the alarm outputs.

The device can be operated by means of two different menus. In both menus, the menu items are selected using the parameter key. The settings in the selected menu item can be modified using the arrow keys.

Shortly press the parameter key to open the display menu. In this menu, the current measured values, the minimum and maximum values and the switching points of the alarm outputs can be selected. If no key is pressed for more than two minutes, the device returns automatically to the main display.

If the parameter key is pressed for more than 2 s, the configuration menu opens. It can be used to configure the measuring input (sensor signal), both alarm outputs and the analog output.

The configuration menu of the display is left automatically after the last menu item or if no key is pressed for more than 2 minutes. It can also be quitted at any time by a long press on the parameter key.

The labels included in the delivery can be placed on the unit field to indicate the desired measuring unit (e.g. m/s, m³/h, ...) of the main display.

States of the alarm outputs





Display	State
	Alarm output 1 not activated Alarm output 2 not activated
	Alarm output 1 activated Alarm output 2 not activated
	Alarm output 1 not activated Alarm output 2 activated
	Alarm output 1 activated Alarm output 2 activated

Table 3

Information regarding the display



Menu item is only displayed if the respective configuration is selected

Display menu

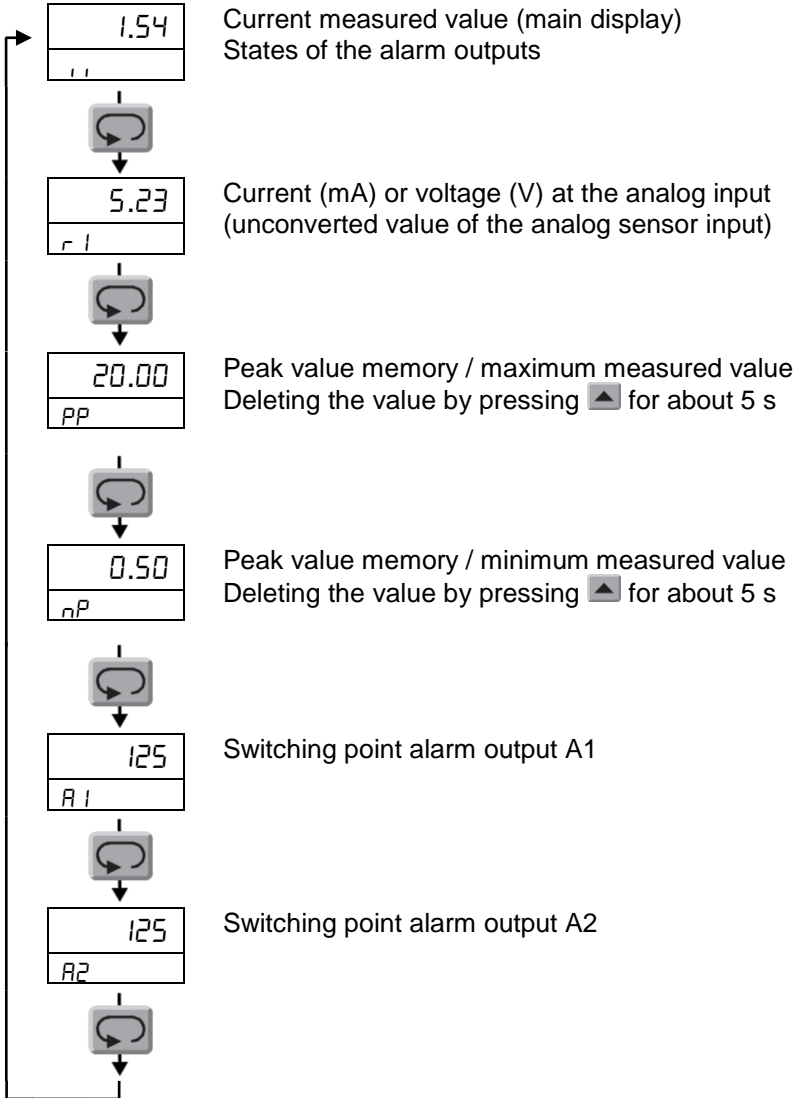

Configuration menu

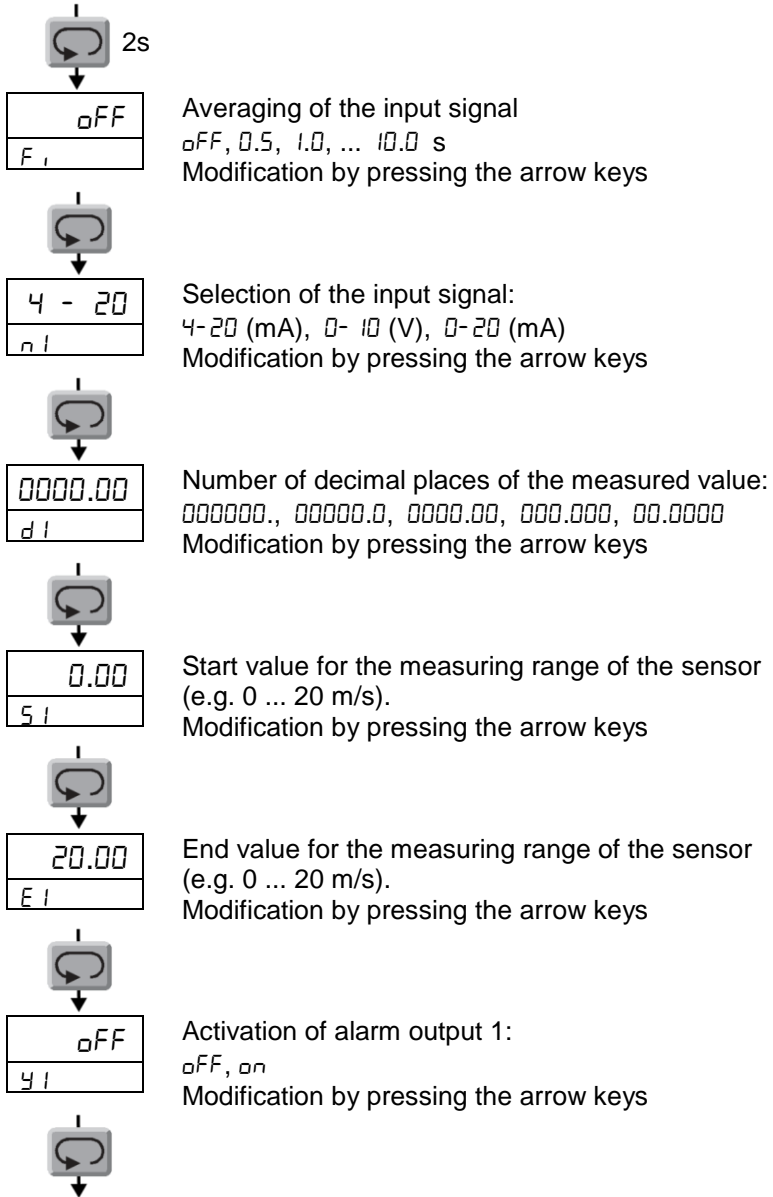

onr
42

Switching behavior alarm output 1:

onr (Switches as soon as the switching point is exceeded)

onL (Switches if the value falls below the switching point)

Modification by pressing the arrow keys



5.00
43

Switching point alarm output 1:

Modification by pressing the arrow keys



0.50
44

Hysteresis alarm output 1 (four digits)

Modification by pressing the arrow keys



0.00.00
45

Response delay alarm output 1:

0.00.00 ... 9.00.00 (h.mm.ss)

Modification by pressing the arrow keys



0.00.00
46

Release delay alarm output 1:

0.00.00 ... 9.00.00 (h.mm.ss)

Modification by pressing the arrow keys



oFF
21

Activation of alarm output 2:

oFF, on

Modification by pressing the arrow keys

Parameterization alarm output 2 identical to parameterization of alarm output 1 (menu items 22 to 26)



oFF
o5

Activation of analog output:

oFF, on

Modification by pressing the arrow keys



4 - 20
no

Selecting the signal mode of output signal:
 4-20 (mA), 0-10 (V), 0-20 (mA)
 Modification by pressing the arrow keys



0.00
50

Start value for display range of analog output
 Modification by pressing the arrow keys



20.00
Er

End value for indication range of analog output
 Modification by pressing the arrow keys



oFF
Lc

Key lock:
 oFF, on
 Modifications in the configuration menu and reset of
 the peak value memory are locked
 Modification using the arrow keys even if the key
 lock is active



1.54
..

Return to the main display

Application example

The volume flow in a measuring tube with DN 80 is to be measured. Alarm should be sent to the alarm output 1 as soon as 500 m³/h is exceeded. The analog output should convert the area of 0 ... 600 m³/h to 0 ... 10 V.

Sensor data:

- Measuring range 0...60 m/s or 0 ... 920 m³/h in the tube DN 80.
- Analog output 4 ... 20 mA

Determining the volume flow measuring range using the data sheet of the sensor or with the help of the **SCHMIDT**[®] flow calculator on our homepage (www.schmidttechnology.de).

Note: Plug the jumper in the housing cover for current measurement.

Menu item	Setting	Meaning
n1	4 - 20	Signal mode analog input: 4 ... 20 mA
d1	0000.00	Display accuracy: 2 decimal places
S1	0.00	Start value: 0 m ³ /h (corresponds to 4 mA)
E1	920.00	End value: 920 m ³ /h (corresponds to 20 mA)
y1	on	Configuration alarm output 1: ➤ Activation of the alarm output ➤ Switching mode: active when exceeded ➤ Switching point: 500 m ³ /h ➤ Switching hysteresis: 10 m ³ /h (alarm output is released if the value falls below 490 m ³ /h) ➤ Response delay: 30 s ➤ Release delay: 30 s
y2	onr	
y3	500.00	
y4	10.00	
y5	0.00.30	
y6	0.00.30	
z1	oFF	Alarm output 2: deactivated
a5	on	Configuration analog output: ➤ Signal mode: 0 ... 10 V ➤ Start value: 0 m ³ /h (\pm 0 V) ➤ End value: 600 m ³ /h (\pm 10 V)
no	0 - 10	
So	0.00	
EO	600.00	

Table 4: Configuration example

7 Service information

Eliminating malfunctions

The following table lists possible errors (error images). A description of the way to detect errors is given. Furthermore, the possible causes and measures to be taken to eliminate errors are listed.

Error image	Possible causes	Troubleshooting
Displays off, analog output to zero	Supply voltage U_B : <ul style="list-style-type: none"> ➤ No U_B present ➤ U_B (DC) has wrong polarity ➤ U_B too low Measured value display defective	Supply voltage: <ul style="list-style-type: none"> ➤ Check if connected correctly to control unit ➤ Check the voltage type (DC, AC) ➤ Check if there is supply voltage at the terminal (cable break)
Measuring range too large /small	Defective configuration of the sensor's measuring range	<ul style="list-style-type: none"> ➤ Check whether the analog measuring value is correct (r !) ➤ Configuration of start (S !) and end value (E !) of the sensor's measuring range
Analog measuring value (r !)	Jumper signal mode analog input	➤ Set the jumper in accordance with the signal mode
	Input configuration	➤ Check the input configuration (r !)
Analog signal too large /small	Output configuration	➤ Check configuration
Unexpected values at the alarm output	Configuration alarm output	➤ Check configuration

Table 5

8 Technical data

Technical data	
Display	Seven segments LEDs red, height 14,2 mm, 6 digits Additional display: 2 digits, 7 mm
Input signal	1 x 4 ... 20 mA ($R_i = 100 \Omega$) or 0 ... 10 V ($R_i \geq 10 \text{ k}\Omega$)
Analog output	1 x 4 ... 20 mA / 2 ... 10 V or 0 ... 20 mA / 0 ... 10 V (depending on the resistance, galvanically isolated, short-circuit protected) Voltage output: > 500 Ω Current output: < 500 Ω
Relay outputs	2 relay changeover contacts (potential-free), max. 250 VAC / 5 A
Accuracy analog output	$\pm 0.2 \%$ of measured value
Supply voltage	
Material no.: 527320	85 - 250 VAC, 50 ... 60 Hz
Material no.: 528240	18 - 30 VDC
Current consumption	Max. 8 VA
Current supply of flow sensor	24 VDC $\pm 15 \%$, max. 160 mA (short-circuit proof)
Operating temperature	-20 ... +60°C
Storage/transport temperature	-40 ... +70°C
Environmental conditions	Non-condensing (up to 95 % relative humidity)
Connection	14 spring clamp, one conductor 1.5 mm ² , 4 through-bolt joints
Operating position	any
Ingress protection / Protection class	IP65, contact protected
Housing material	Polyamide, glass-fiber reinforced (PA6-GF 15/15), color similar to RAL 7001
Weight	approx. 370 g

Table 6

9 EC Declaration of conformity

EG-Konformitätserklärung

Certificate of Conformity

Déclaration de conformité CE



SCHMIDT Technology GmbH erklärt, dass das Produkt
SCHMIDT Technology GmbH herewith declares that the product
SCHMIDT Technology GmbH déclare que le produit

SCHMIDT® MD 10.010
MD 10.015

Part-No.: **527 320 / 528 240**
527 330 / 528 250

den wesentlichen Schutzanforderungen entspricht, die in der Richtlinie des Rates zur Angleichung der Rechtsvorschriften der Mitgliedsstaaten über elektromagnetische Verträglichkeit (2004/108/EG) festgelegt sind.

is in compliance with the relevant protection requirements in respect of the electromagnetic compatibility (EMC) which are laid down in the guidelines of the council for the harmonization of the regulations of the members within the European community (2004/108/EG).

correspond aux prescriptions de protection établies dans la norme du conseil pour l'harmonisation de règles de droit des Etats membre sur la compatibilité électromagnétique (2004/108/EG).

Zur Beurteilung hinsichtlich elektromagnetischer Verträglichkeit wurden folgende Normen herangezogen:

The assessment of EMC for industrial applications refers to the following European standards:

Pour le jugement de la compatibilité électromagnétique normes suivantes sont appliquées:

- a) Störaussendung (Emission) / Electromagnetic Emission / Interférence
EN 61000-6-3:2007

- b) Störfestigkeit / Electromagnetic Immunity / Immunité aux parasites
EN 61000-6-2:2005

A handwritten signature in blue ink, appearing to read "Scholz", is written over a horizontal line. Below the line, the name "Helmar Scholz" is printed in a small, black, sans-serif font.

Helmar Scholz

Leiter Entwicklung Sensoren / R&D Manager Division Sensors / Directeur développement capteur

St. Georgen, Januar 2011 / January 2011 / Janvier 2011



Notes

SCHMIDT Technology GmbH

Feldbergstrasse 1

78112 St. Georgen / Schwarzwald

Phone +49 (0)7724 / 899-0

Fax +49 (0)7724 / 899-101

info@schmidttechnology.de

www.schmidttechnology.de