

# LSE-HD - Purging Facility for SDF Flow Sensors



# LSE-HD - Purging Facility for SDF Flow Sensors

## Field of application

The purging facility LSE-HD is used with our SDF sensor (or any other pitot type tube) in gaseous media which are highly dustloaded, e. g dust in waste air. Used regularly it avoids clogging of the measure openings in the sensor profile by the pollution which goes with the medium and which would influence correct measurements. If and how often the sensor has to be cleaned, depends on the particular application. As rule of thumb it can be said that pollutions up to 150 mg/m<sup>3</sup> do not require a regular purging. Pollution over 300 mg/m<sup>3</sup> makes a regular purging with our purging facility LSE-HD absolutely necessary in order to receive reasonable measurement results. In the range between 150 and 300 mg/m<sup>3</sup> it is recommended to consider a purging facility when observations show excessive pollution.

## Function

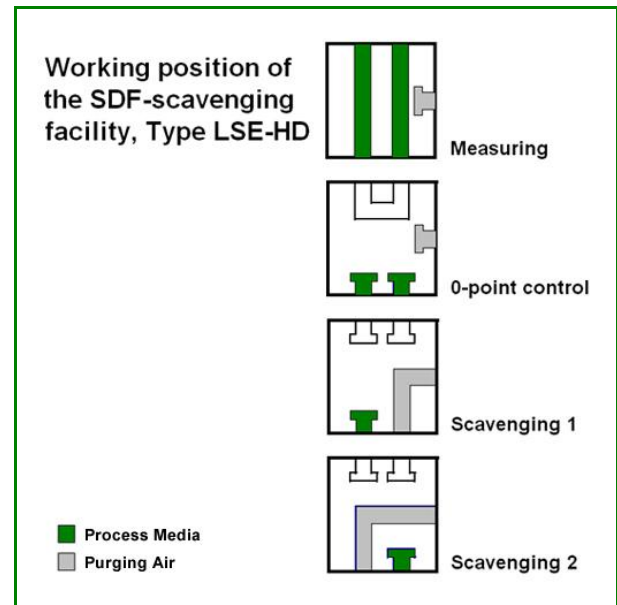
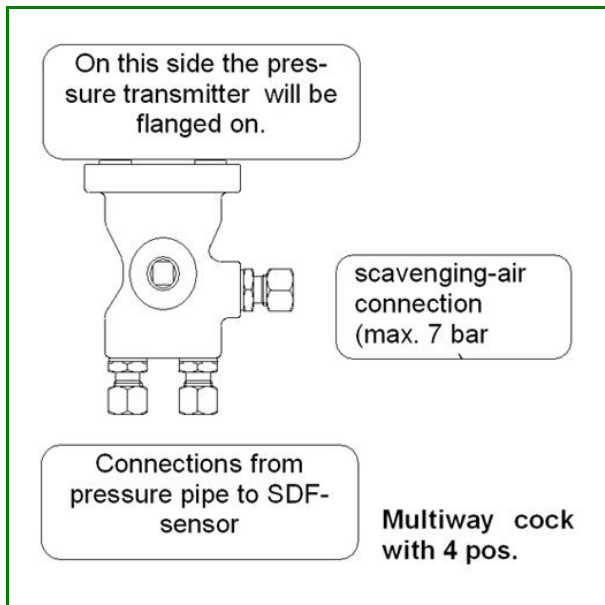

The function of the purging facility is to clean both chambers of the connected sensor with compressed air in order to avoid respectively remove clogging of and from the bore-holes. First of all the flanged-on differential pressure transmitter has to be disconnected at both ends from the pressure piping. Then both pressure pipes including the sensor chambers will be put under compressed air and purged separately and one after the other. Central element of the

purging facility is the multiway cock, shown in the drawing on the left, with its four working positions. The procedure to scavenge both chambers separately and one after the other has, compared to competitor's products, one essential advantage: It works! Should a chamber really be clogged the compressed air will not escape unused through the chamber that is clean anyhow. The multiway cock will be operated by hand depending on the equipment of the purging facility or

# LSE-HD - Purging Facility for SDF Flow Sensors

automatically by an electric drive. Before starting both purgings the d/p-pressure transmitter will be disconnected from the process by the multiway cock then both transmitter chambers connected with each other over a compensating channel in order to provide a

zero point control of the pressure transmitter.

Equipped with a controlling computer  $\mu$ FLOW-LSE the LSE-HD will initiate the zero offset control automatically whereas a relais contact reports inadmissible (adjustable!) offset deviation.

## Equipment

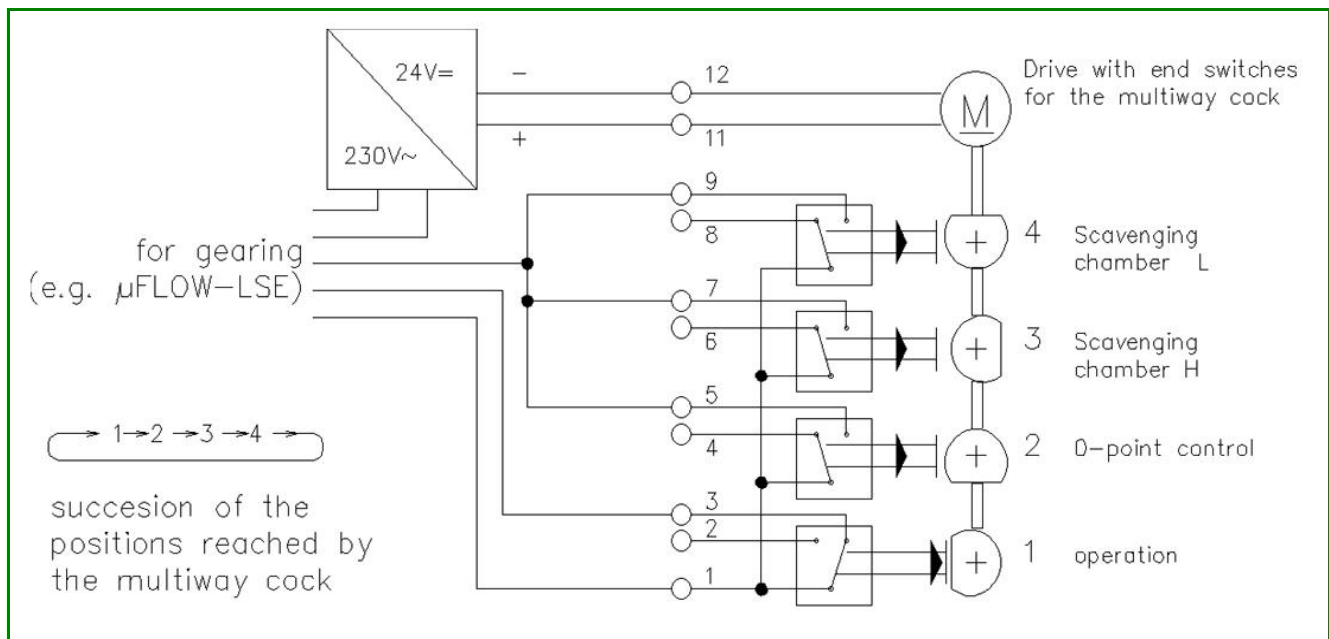

A glimpse to the table with order-details (last page) will give you an impression of the various possibilities offered by our purging facility LSE-HD in regard to equipment and functionality. Requirements for an automatic purging will be met by an electrical drive which replaces the manual crank of the multiway cock. This drive contains four cam switches, being operated when the corresponding working position is reached and this way gives the information about the cock position to the connected gear. The gearing is generally done by the compact computer  $\mu$ FLOW-LSE which is either directly integrated in the purging facility (then a protecting case is absolutely essential) or is installed, e.g. in the switch cabinet where it gives the operator information about the purging cyclus. Integrated in the purging facility or not the  $\mu$ FLOW LSE can be used for the determination of the volume flow or even of the standard volume flow (depending on the order-option). For density corrections (under standard conditions: 0°C, 101.3 kPa abs) the medium's temperature will be given to the  $\mu$ FLOW-LSE as a Pt100-signal or a 4..20 mA signal and process pressure as a 4..20 mA signal.

# LSE-HD - Purging Facility for SDF Flow Sensors

## Technical Data:

Multiway cock	
Material	1.4571
Pressure gauge	PN100
Function	Four positions: operating, offset control, purging side 1 and side 2
Connection	Directly flangeable to the pressure transmitter, flange acc. to DIN 19213
Manual crank	Aluminium, black anodized

Drive	
Operating voltage	230 VAC over transformer-rectifying aggregate
Function	four positions with cam switch
Rated torque	23 Nm
Turning time for 90°	ca. 8 s
Power input starting stage	circa 70 VA for approx. 1 s
Power input operating	circa 40 VA
Protection	IP 65

Protecting case	
Material	Hot pressed, glass-fibre-reinforced polyester
Colour	pebble-grey RAL 7032 coloured
Sealing	Neoprene
Protection	IP 65
External dimensions	ca. 600 x 400 x 430 mm (H x W x D)

Heating	
Operating voltage	230 VAC
Power	500 W
Function	thermostatically regulated, with control lamp
Setting	+5..+45°C

μFLOW-LSE	
Operating voltage	230 VAC
Case	Switchboard installation case according to DIN 43700
External dimension	72 x 144 x 185 mm (H x B x T)
Display	2-line LC-Display, 8 mm height of characters

# LSE-HD - Purging Facility for SDF Flow Sensors

<b>μFLOW-LSE</b>	
Keyboard	Five key pads
Protection	Operating front IP 64
Manual purging	Possible over menu point MANUAL
Setting purging-time	5...60 s
Setting purging-interval	1...6000 min
Zero point control of the pressure transmitter	alarm signal when exceeding the tolerable deviation (display and relais contact)
Other	see operating manual μFLOW-LSE

<b>Other</b>	
Electrical connection in case	on row-terminals via wiring-screw joint PG11
Pneumatic connection	cutting-ring joint made out of material 1.4571 for stainless steel tube 12x1 mm (2x differential pressure tube, 1x purging air connection)
purging air	compressed air max. 7 bar
Piping in protecting case	tube 12x1 mm, material 1.4571

- technical data is subject to change -

## Abstract

separate purging of both differential pressure tubes, standard even for the most simple version  
multiway cock as a central element provides zero point control of the d/p-transmitter  
for field applications: installation in heated glass-fibre protection case.  
automation possible by installing an electrical drive for the multiway cock.

## Additional possibilities by using an integrated $\mu$ FLOW LSE controller:

- automatic run of the necessary purging cycle
- signal holding of the flow value during purging
- display of the operating stage during and between purging procedure.
- automatic zero point control of the differential pressure transmitter; alarm (display and relais contact) when exceeding the tolerable zero point deviation (adjustable)
- adjustment of purging duration and purging interval, independently from each other via keyboard.
- determination of the standard volume flow (option) by compensating the influence of temperature and pressure (suitable sensors have to be connected)
- 4..20 mA output (gavanically isolated) for standard volume flow
- digital output (NPN open collector) as a status signal ( purging in progress )
- power supply for all connected transmitters

# LSE-HD - Purging Facility for SDF Flow Sensors

## Order details

LSE-HD	-	-	-	-	-	-	-	-	-	
										<b>Drive and Gear</b>
		MH								manually with hand crank
		EO								electrically without gear
		EI								electrically, geared by built-in $\mu$ Flow-LSE
		EE								electrically, geared by external $\mu$ Flow-LSE
		X1								special versions (upon request)
										<b>Volume flow calculation</b>
				O						without
				K						by $\mu$ Flow-LSE without density correction
				D						by $\mu$ Flow-LSE with density correction (signal of connected temperature and pressure sensors are required)
				X2						special versions (upon request)
										<b>Protection case</b>
						OO				Without case, without mounting plate
						OP				Without case, installed on mounting plate
						SO				Protecting case without window
						SF				Protecting case with window (acrylic glass)
						X3				special version (upon request)
										<b>Protection case heating</b>
							O			without
							H			Electrical heating 500 W
							X4			special version (upon request)
										<b>Mounting accessories</b>
								O		without
								W		Wall rack
								R		Tube clamp for 2 tube
								X5		special versions (upon request)



**S.K.I. Schlegel & Kremer Industrieautomation GmbH**

Postbox 20 12 11  
D-41212 Moenchengladbach

Gerberstr.49  
D-41199 Moenchengladbach

Phone +49 (0) 2166/62317-0  
Fax +49 (0) 2166/611681

Web: [www.ski-gmbh.com](http://www.ski-gmbh.com)  
E-Mail: [info@ski-gmbh.com](mailto:info@ski-gmbh.com)

*Trademarks and logos of other suppliers are their property*