



---

# **SDF-flow sensors**

## **for gases and liquids**

# **Operating and Mounting Instructions**

S.K.I. Schlegel & Kremer Industrieautomation GmbH  
Gerberstr. 49 - 41199 Mönchengladbach - Germany  
Telefon: ++49-2166/62317-0 - Telefax: ++49-2166/611681

## **Content**

1	General Notes .....	3
1.1	Explanations of the symbols.....	3
1.2	General Hints .....	3
1.3	Qualified Personnel .....	3
1.4	Cleaning .....	3
2	Incoming inspection.....	4
3	Ordering key for standard SDF-sensors .....	5
4	Mounting instructions .....	6
4.1	General note.....	6
4.2	Determination of the mounting location.....	6
4.3	Determination of the mounting position.....	6
4.3.1	Horizontal pipe run: .....	6
4.3.2	Vertical pipe run and existing risk of condensation: .....	7
4.4	Orientation of the SDF flow sensor .....	7
4.5	Fitting of the mounting parts.....	7
4.6	Mounting and alignment of SDF flow-sensor .....	9
	Connecting the differential pressure transmitter to the sensor .....	10
5.1	Sensor with mounting plate for direct connection of the transmitter to the sensor.....	10
5.2	Sensor with connector nipples for connection of the transmitter via differential pressure lines.....	11
5.2.1	Connecting the differential pressure pipes at <u>gaseous</u> media.....	11
5.2.2	Connecting the differential pressure pipes at <u>liquid</u> media .....	12
6	Troubleshooting.....	13

# 1 General Notes

## 1.1 Explanations of the symbols



Warning of a danger place (caution: consider documentation)  
ISO 3864, No. B.3.1

## 1.2 General Hints

For reasons of clarity this manual does not contain detailed information about all types of products and cannot take into account every conceivable case of installation, operation or maintenance.

If you require further information or should problems occur which are not sufficiently explained in the manual, you can consult us directly to obtain the necessary information.

### **CAUTION**



This equipment should only be installed and operated after qualified personnel have ensured that during normal operation or in case of a defect in the system or in components no hazardous situation can occur. Therefore serious injuries and/or considerable material damage cannot be ruled out in the event of improper handling of the device.

The perfect and safe operation of this equipment is conditional upon proper transport, proper storage, installation and assembly as well as on careful operation and commissioning.

May we also draw your attention to the fact that the contents of the manual are not part of a previous or existing agreement, approval or legal relationship or an amendment thereof. All obligations of the S.K.I. GmbH result from the contract of purchase which also contains the full and solely valid warranty agreement. These contractual warranty conditions are neither extended nor restricted by the contents of the manual.

## 1.3 Qualified Personnel



are persons familiar with the installation, assembly, commissioning and operation of the product and who have the appropriate qualifications for their activities such as:

- Training or instruction or authorization to operate and maintain devices/systems according to the standard of safety technology for high pressure parts.
- Training or instruction in the proper care and use of protective equipment in accordance with appropriate safety practices.
- Rendering first aid.



**Caution: Before the installation and operation the piping and process data should be checked with the specifications on the type plate and the delivery note. Only the specifications on the type plate of the equipment are valid.**

## 1.4 Cleaning

Outside sediments on the pitot tube can be cleaned (when dismantled) with a wire brush. It is to be made certain that the profile geometry and the profiles are not damaged.

The measuring chambers can be blown free with compressed air. Please note that the pitot tube consists of two measuring chambers (upstream and downstream).

Dependent on the degree of contamination of the process medium the pitot tube must be checked however for contamination / blockages and damages. The maintenance intervals are to be determined depending upon system. Experience shows that with the usual maintenance at the latest also the pitot tube should be checked.

## 2 Incoming inspection

Each delivery leaving S.K.I. GmbH is carefully inspected to the best knowledge. On the packing list included, the employee responsible for the delivery confirms with his signature that the delivery contains all the items specified in the delivery documents.

Nevertheless, it is necessary for the customer to carry out a crosscheck as soon as possible after receipt of the delivery. Only then justified complaints can be settled quickly and without further discussion.

### On receipt of the delivery please check:

if the rating plate corresponds to that indicated on the delivery note

if the version delivered corresponds to the version ordered especially with respect to sensor length, sensor material and mounting parts material, insofar as this is possible

if the scope of delivery corresponds to the standard delivery list

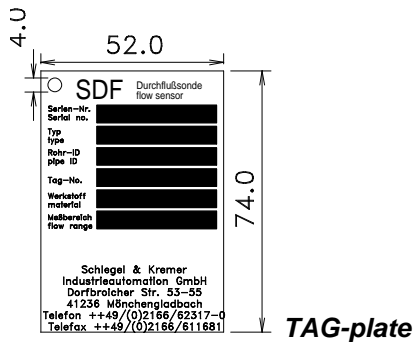

Calculation for SDF - flow sensor under standard flow conditions			
doc. no.:			
sensor-type:	SDF-F-10-70,3mm-2,9mm-S-C-0-PN16-FP-DE-0-H		
k-factor:	0.6087		
serial no.:	0212682		
<b><u>stream data</u></b>		<b><u>norm</u></b>	<b><u>min</u></b>
medium:		natural gas	
standard density:	kg/Nm <sup>3</sup>		0.85
pressure:	kPa abs.		112.8
temperature:	°C		25
standard flow:	Nm <sup>3</sup> /h		160
viscosity:	m <sup>2</sup> /s		1.7E-5
<b><u>pipe data</u></b>			
pipe cross-section:		round	
inner diameter:	mm	70.3	
geometr. diameter:	mm	70.3	
hydraul. diameter:	mm	70.3	
<b><u>calculated data</u></b>		<b><u>norm</u></b>	<b><u>min</u></b>
operating density:	kg/m <sup>3</sup>		.87
operating volume flow:	m <sup>3</sup> /h		156.9
flow:	m/s		11.23
Reynoldsnumber:			46426
f.Re:			1
<b>differential pressure:</b>	<b>mbar</b>		<b>1.47</b>

set point for dp-transmitter

*differential pressure calculation*

### 3 Ordering key for standard SDF-sensors

SDF-	-	-	-	-	-	-	-	-	-	-	-	-	-	-
M F X														
	10 22 32 50													
		S R H HT X												
			C E X											
				0 SC GF X										
					R2 R4 N2 N4 R S FP X									
						0 KC KE AC AE AH DC DE								
							0 VC VE DSC DSE UC UE CH IH							
													H V	
<b>Pipeline mounting</b>														
Welding socket with cutting ring joint														
Mounting flange														
Special version														
<b>Profile type</b>														
"10"														
"22"														
"32"														
"50"														
<b>Internal diameter</b> (value with dimension)														
<b>Wall thickness</b> (value with dimension)														
<b>Sensor material</b>														
M.No. 1.4571 (316 Ti)														
M.No. 1.4539														
M.No. 2.4819 (Hastelloy C276)														
M.No. 2.4816 (Inconel 602)														
Special material														
<b>Mounting parts material</b>														
Carbon steel														
M.No. 1.4571														
Special version														
<b>End support</b>														
none														
End support with pipe thread and hood														
End support with flange														
Special version														
<b>Pressure stage</b> (e.g. „PN16“, „300 lbs“ or similar)														
<b>Process connections</b>														
Nipple with R1/2" male thread														
Nipple with R1/4" male thread														
Nipple with 1/2-14-NPT male thread														
Nipple with 1/4-18-NPT male thread														
Small pipe 12 mm														
Hose stem Ø10.5x1.5														
Flange plate for mounting of 3-way valve														
Special version														
<b>Primary shut-off</b>														
none														
Ball valves made of carbon steel														
Ball valves made of 1.4401														
Shut-off valves PN420 made of carbon steel														
Shut-off valves PN420 made of 1.4571														
Shut-off valves PN420 made of 1.7335														
mounted 3-way valve of carbon steel (only with flange plate)														
mounted 3-way valve of 1.4401 (only with flange plate)														
<b>Special accessories</b>														
none														
1 pair of screw joints for pipe connection 12 mm of carbon steel														
1 pair of screw joints for pipe connection 12 mm of 1.4571														
3-way manifold with 1/2"-NPT socket connection for direct mounting to electrical differential pressure transmitter, carbon steel														
3-way manifold as above, but material 1.4571														
Multiway cock PN100 with scavenging connections of carbon steel														
Multiway cock PN100 with scavenging connections of 1.4401														
One-side cleaning openings for compressed air connection														
compressed air connection ruckluftanschluß														
Inspection and cleaning openings (only practical with end supports)														
<b>Pipe run</b>														
Horizontal														
Vertical (also inclined run)														

## 4 Mounting instructions

### 4.1 General note

With the installation the valid national regulations are to be considered, in particular:



- The regulations of the Druckgeraeterichtlinie (pressure device directive) 97/23/EG (if applicable).
- The regulations of the Maschinenrichtlinie (machine directive) 98/37/EG (if applicable).
- Before the assembly/disassembly the piping or the channel is to be made pressure-free.
- Poisonous / health-endangering media: before the assembly/disassembly the piping is to be cleaned.

### 4.2 Determination of the mounting location

Determine the longest straight section of the pipeline or channel and divide this into upstream and downstream distance respectively according to the table below.

Required steadying zones		
Pipe run	Up-stream	Down-stream
<p><b>one pipe bending</b> Ein Rohrbogen</p>	<b>7*ID</b>	<b>3*ID</b>
<p><b>two pipe bendings</b> Zwei Rohrbogen</p>	<b>10*ID</b>	<b>3*ID</b>
<p><b>reduction</b> Einschnürung</p>	<b>7*ID</b>	<b>3*ID</b>
<p><b>controlling element</b> Regelorgan</p>	<b>20*ID</b>	<b>5*ID</b>

The indicated upstream and downstream distances are standard values. They can be shortened by „intelligent“ installation. What does „intelligent installation“ mean?

**Example 1: Installation of the sensor behind a bend.** The flow profile mainly deforms on the level of the pipe bend. Therefore the sensor should also be installed on this level in order to actually detect the velocity variations at the different measuring points.

**Example 2: Correct installation is impossible due to structural conditions at the measuring point.** This can be remedied by correction of the k-factor of the SDF sensor (see section „fundamental calculation principles“). This is done by measuring the flow velocity at the sensor mounting location by means of a test apparatus (e.g. a pitostatic tube) and comparing this value with the value displayed on the stationary measuring system. If deviations occur, the application-specific k-factor must be calculated from the calculation formulae and the parameters of the measuring system must be re-adjusted. When required, details can be taken from a special application report.

**If you require more information, please contact our consulting and commissioning service.**

Take into account obstructions existing in front of and behind the selected mounting location. Passive elements (e.g. bends) cause less interference than active elements (e.g. fans). Harmonic changes in the pipe run (bends with large radii, reductions according to DIN) are more favourable than sudden or less harmonic changes (corners, stops). Contact the manufacturer or responsible sales engineer if necessary!

### 4.3 Determination of the mounting position

#### 4.3.1 Horizontal pipe run:

**Gases:** Mount the sensor in the area between position 9.30 (a.m.) and 2.30 (a.m.).

**Liquids:** Mount the sensor in the area between position 3.30 (a.m.) and 8.30 (a.m.).

### 4.3.2 Vertical pipe run and existing risk of condensation:

**Gases:** Incline the sensor mounting position slightly to enable the condensate to flow away from the sensor head back into the process.

**Liquids:** Incline the sensor mounting position slightly to enable air or gas bubbles to return into the process.

## 4.4 Orientation of the SDF flow sensor

The construction of SDF flow sensors is completely symmetrical. For this reason it is irrelevant which of the apertured sensor sides faces the flow. Consequently the arrow indicating the flow direction only shows whether the SDF flow sensor is designed for horizontal or vertical flow. In addition the connections are marked with the letters **LK** (left sensor chamber) and **RK** (right sensor chamber) for horizontal pipelines and with **OK** (upper chamber) and **UK** (lower chamber) for vertical pipelines. The construction of the sensors ensures that the connections are always on the same level. That means that the flow indicating arrow on sensors for vertical pipelines is shifted by 90° with relation to the connections. The sensors must be mounted with the engraved letters being normally readable (in upright position).

The following table shows the allocation of sensor chamber and transmitter connection depending on the pipe run and the direction of flow. The piping or mounting of the transmitter must be carried out accordingly.

pipe run	flow direction		+ side of transmitter	- side of transmitter
horizontal	from left to right	→	LK	RK
horizontal	from right to left	←	RK	LK
vertical	from top to bottom	↓	OK	UK
vertical	from bottom to top	↑	UK	OK

## 4.5 Fitting of the mounting parts

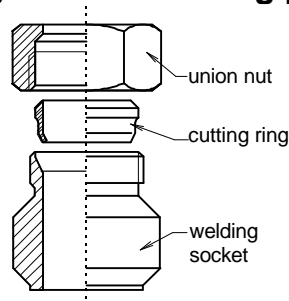

**necessary torque (TA)**

in acc. to ISO 9974-1/ ISO 6149-1/ DIN 3852-T1-Form X/ DIN 3652-T3-Form W (metr. thread)

of mounting-part **for SDF-M:**

- SDF-M-10: TA ≈ 150 Nm
- SDF-M-22: TA ≈ 250 Nm

**SDF-M-10** At the mounting location determined the pipe wall must be provided with a 21 mm diameter hole by boring or burning. The welding socket with **screwed cutting ring connection** must be tack-welded in such a way that the bore hole remains completely unobstructed. Align the inner bore hole of the mounting part in a position perpendicular to the axis of the pipeline and weld it to the pipeline.

**SDF-F-10** At the mounting location determined the pipe wall must be provided with a 17 mm diameter hole by boring or burning. The welding socket with **flange** must be tack-welded in such a way that the alignment of the screw holes relative to the axis of the pipeline meets the generally applicable rules. Make sure that the bore hole in the pipeline remains completely unobstructed, and weld the flange socket to the pipeline.

**SDF-M-22** At the mounting location determined the pipe wall must be provided with a 37 mm diameter hole by boring or burning. The welding socket with **screwed cutting ring connection** must be tack-welded in such a way that the bore hole remains completely unobstructed. Align the inner bore hole of the mounting part in a position perpendicular to the axis of the pipeline and weld it to the pipeline.

**SDF-F-22** At the mounting location determined the pipe wall must be provided with a 38 mm diameter hole by boring or burning. The welding socket with **flange** must be tack-welded in such a way

that the alignment of the screw holes relative to the axis of the pipeline meets the generally applicable rules. Make sure that the bore hole in the pipeline remains completely unobstructed, and weld the flange socket to the pipeline.

**SDF-F-32** At the mounting location determined the pipe wall must be provided with a 38 mm diameter hole by boring or burning. The welding socket with **flange** must be tack-welded in such a way that the alignment of the screw holes relative to the axis of the pipeline meets the generally applicable rules. Make sure that the bore hole in the pipeline remains completely unobstructed, and weld the flange socket to the pipeline.

**SDF-F-50** At the mounting location determined the pipe wall must be provided with a 71 mm diameter hole by boring or burning. The welding socket with **flange** must be tack-welded in such a way that the alignment of the screw holes relative to the axis of the pipeline meets the generally applicable rules. Make sure that the bore hole in the pipeline remains completely unobstructed, and weld the flange socket to the pipeline.

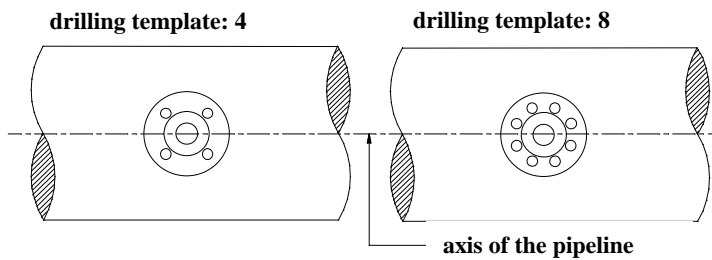

If the sensor is fitted with an **end support** the following mounting procedure is used:

First the mounting location of the end support is determined; it is positioned directly opposite the mounting part.

**Recommended procedure for determining the opposite point:**

First mark the center of the mounting part to be installed on the pipeline. Then pass a tape of at least 30 mm width and appropriate length tightly around the pipeline, and align it in such a way that after one rotation it exactly covers the first layer. Start by holding one end of the tape to the point marked on the pipeline. Mark the tape at the point which after one rotation is directly adjacent to the marked mounting part centre. The distance from the start of the tape to this point is equal to the outer diameter of the pipeline. Remove the tape, determine the centre between the start of the tape and the point marked on the tape, and mark the centre of the tape. Place the tape around the pipeline again as described above. The point marked last on the tape (centre) is the position exactly opposite the mounting part. Finally you only have to transfer this point to the pipeline. If there is no tape available you can also use a cord to determine the diameter. In this case it is important to check the axial alignment of the cord by measuring the distance to the next flange.

The mounting part is then mounted as described above. At the opposite point (see above) a hole of appropriate size is subsequently bored or burned into the pipe wall. Select the appropriate diameter from the following table:

sensor type	end support with pipe thread and hood (SC)	end support with flange (GF)
SDF-...-22	28 mm	36 mm
SDF-...-32	36 mm	38 mm
SDF-...-50	54 mm	70 mm

The end support is tack-welded to the pipeline and aligned with the mounting part previously welded to the pipeline. This ensures perfect insertion of the sensor without tilting.

Attention: For welding end support it is necessary to keep the following values: SDF-22=26mm, SDF-32=34mm).

Make sure that the bore hole in the pipeline remains completely unobstructed, and weld the end support to the pipeline.

**Recommended procedure for end support alignment**

After making the boring insert the sensor or a straight pipe with appropriate outer diameter through the mounting part already mounted, and loosely slide the end support over the projecting sensor end or

pipe. When the end support is correctly aligned (do not tilt!) tack it to the pipeline. Remove the sensor or pipe, and complete the welding.

After the sensor has been mounted cover the end support with the supplied cap or blind flange, depending on the version.

#### 4.6 Mounting and alignment of SDF flow-sensor

- SDF-M-10** After all mounting parts are attached the sensor can be inserted into the union nut only easily screwed onto the welding flange. The flow direction marker on the sensor head must point exactly in direction of flow. It is to be made certain that the sensor touches the opposite tube wall. The distance between the external tube wall and the lower edge of the sensor head amounts to approx. 80 mm plus possibly available neck extension H.
- SDF-F-10** After all mounting parts are attached, the sensor can be inserted after bringing in a seal between assembly flange and sensor flange. The flow direction marker on the sensor head must point thereby exactly in direction of flow. Finally both flanges are bolted together.
- SDF-M-22** After all mounting parts are attached the sensor can be inserted into the union nut only easily screwed onto the welding flange. The flow direction marker on the sensor head must point exactly in direction of flow. Two cases are to be differentiated. When assembling **without** end supports the procedure corresponds to the one of sensor SDF-M-10, i. e. the sensor is inserted until it touches the opposite tube wall. When assembling **with** end supports the sensor is inserted until the distance between the external tube wall and the lower edge of the sensor head amounts to approx. 100 mm plus possibly available neck extension H. The sensor point then reaches approx. 30 mm into the back support. Finally the union nut is firmly tightened.
- SDF-F-22** The procedure corresponds to the one of sensor **SDF-F-10**.
- SDF-F-32** The procedure corresponds to the one of sensor **SDF-F-10**.
- SDF-F-50** The procedure corresponds to the one of sensor **SDF-F-10**.

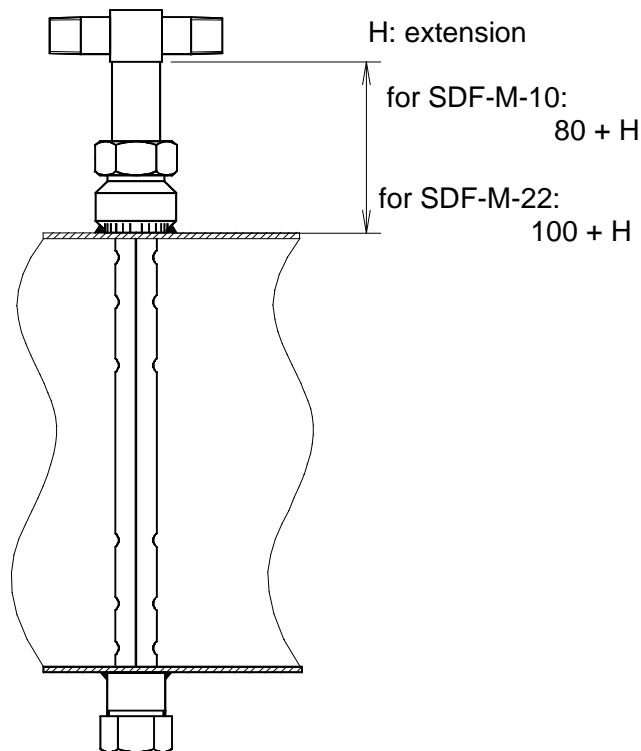

## 5 Connecting the differential pressure transmitter to the sensor

### 5.1 Sensor with mounting plate for direct connection of the transmitter to the sensor

Sensors with a mounting plate for direct connection of the transmitter offer the most simple and economical way of connecting sensor and transmitter. Sensor, three-way manifold and transmitter thus form a kind of "sandwich" connected by means of 8 screws (4 on either side). This arrangement requires that the permissible temperatures at the transmitter diaphragm are not exceeded. The ⊕-side of the transmitter must be connected to the sensor flow side, i.e. the front side of the sensor when looking in the direction of the arrow (see figure). Both sealing faces - the one between sensor and valve block as well as the one between valve block and transmitter - must be fitted on one side with a sealing ring which must be inserted in the groove provided for this purpose. These sealing rings are part of the scope of delivery.

The three-way manifold is usually delivered mounted to the transmitter. The seals are inserted in the grooves and fixed with adhesive tape which, at the same time, covers the bore holes. Before mounting the tape must always be removed.

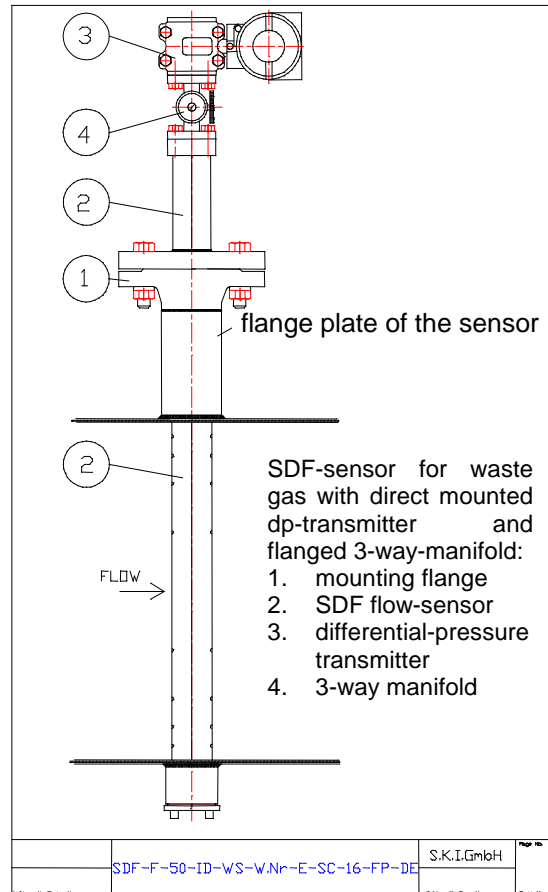

Thus a complete parts list for the commissioning of the sensor must comprise the following:

- sensor including mounting parts for mounting into the pipeline
- 1 ea. three-way manifold (version for mounting between flanges) for direct mounting to the transmitter and sensor including gaskets and screws
- 1 ea. differential pressure transmitter; a mounting support is not required!

## 5.2 Sensor with connector nipples for connection of the transmitter via differential pressure lines

If the transmitter is not mounted directly onto the sensor, it is connected via differential pressure lines. Usually pipes are used which are connected to the sensor and the transmitter by means of screwed connections. Normally screwed connections with cutting or clamping rings are used which allow the process connections to be adapted to the selected pipe connection with a diameter of 12 mm. On request these screwed connections can be obtained from S.K.I. GmbH.

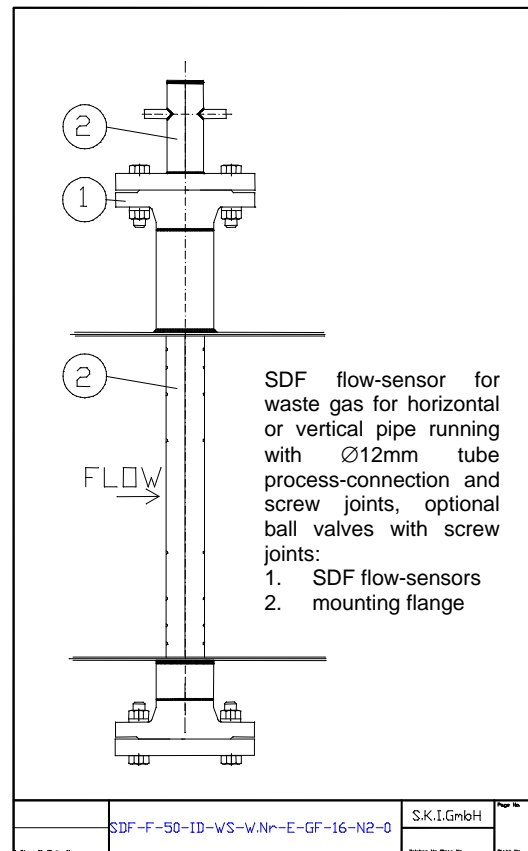

Thus a complete parts list for the commissioning of the sensor must comprise the following:

- sensor including mounting parts for mounting into the pipeline
- 2 ea. ball valves for the primary shut-off of the differential pressure lines of the sensor ea. fittings for adaption of both the process connections to the 12 mm diameter pipeline and the pipeline to the three-way manifold (1/2" 14 NPT female thread)
- 1 ea. three-way manifold for direct mounting to the transmitter with 1/2" 14 NPT female thread process connection including all screws and gaskets as well as, if required, the necessary oval adapters
- 1 ea. differential pressure transmitter with a pipe or wall mounting support
- and an adequate length of pipeline with 12 mm diameter

Please inform your responsible sales engineer or representative if you wish the commissioning of the sensors to be carried out by S.K.I. GmbH.

### 5.2.1 Connecting the differential pressure pipes at gaseous media

The pressure pipes must rise monotonously, i.e. the transmitter must be located above the SDF flow-sensor and the connecting pipes must not contain any sections inclined towards the transmitter. Should this be impossible due to spatial conditions the first section of the piping must be laid so that it is rising. At each of the lower ends of the following falling pipes a condensate vessel must be installed which is drained regularly.

Ensure that the compensation valve of the three-way manifold is open during draining. Contact our sales engineers if you have any questions.

When the sensor is mounted into the pipeline, special attention must be paid to the problem of vapour condensate formation within the pressure pipes. This is particularly important when the medium temperature is well above the ambient temperature. Here you must be aware on the fact that vapour dissolved in the medium may condensate if, somewhere at the pressure pipe from the sensor to the transmitter, the temperature falls below the dew point. This fact can be illustrated by the following example:

Water vapour in a bathroom condensates on a cold mirror surface and forms tiny water droplets. With the amount of condensate increasing, drops are formed which finally begin to flow down the mirror. The pressure line piping must therefore be in such a way that possible condensate will not flow towards the transmitter but back into the process. Just imagine: 10 mm of water column corresponds to 1 mbar differential pressure, which means for the measurement of gaseous media that even a small amount of condensate may cause a measuring error in the same order of magnitude as the effective signal itself.

### **5.2.2 Connecting the differential pressure pipes at liquid media**

The pressure pipes must fall monotonously, i.e. the transmitter must be arranged below the sensor and the connecting pipes must not contain any sections rising in the direction of the transmitter. Should this be impossible due to spatial conditions the first section of the piping must be inclined. The piping of the rising lines that follow must be laid in such a way that bleeding is possible at the highest point (e.g. the screw plug at the back of the transmitter). The pipelines must occasionally be bled. Ensure that the compensation valve of the three-way manifold is open during bleeding. Please contact our sales engineers if you have any questions.

## 6 Troubleshooting

Pos.	Description of the failure	Possible reason
1	No or too small differential pressure	Sensor is not installed in direction of the flow
		The ⊕ and ⊖ connections between sensor and transmitter are exchanged (look at page 7) (the upstream side of the sensor is not connected with the "+" chamber of the transmitter and the downstream side is not connected to the "-" chamber of the transmitter.
		Primary shut off valve „+“ and/or „-“ side is not opened
		Short cut valve (part of the 3-way-manifold) is not closed
		Leakages in the pressure lines
		Blocking of the sensor especially of the openings
		Steadying zones in front and behind the sensor are not long enough (look at page <b>Fehler! Textmarke nicht definiert.</b> )
		Air bubbles in the sensor head/ pressure lines or transmitter (I.a. pos. 3 / <i>only during condensate measurement</i> )
		Condensated water in sensor head / differential pressure lines or transmitter (I.a. pos. 4 / <i>only during gas measurement</i> )
		Not all sensor openings are located in the cross section of the pipe/duct (look at page 9)
2	Measuring range exceeding	Steadying zones in front of and behind the sensor are not long enough (look at page <b>Fehler! Textmarke nicht definiert.</b> )
		Primary shut off valve „+“ and/or „-“ side is not opened
		Sensor/drillings clogged
		Sensor not completely in free tubing cross section with all drillings (I.a. page 9)
3	Trapped air in the sensor/ differential pressure lines and/or transmitter ( <i>liquid media measurements</i> )	Wrong mounting of the pitot tube (I.a. page 6)
		Incorrect venting (I.a. operating instruction differential pressure transmitters)
4	Water condensation in sensor / differential pressure lines and / or transmitter ( <i>gas measurements</i> )	Wrong mounting of the pitot tube (I.a. page 6)
	Differential pressure transmitters	
5	No or false output signal	Wrong mounting of the transmitter (I.a. operating instruction for differential pressure transmitters)
		Wrong electrical connection of the d/p transmitter (I.a. operating instruction transmitters)
		Wrong parameterization of the transmitter (I.a. calculation sheet of the flow sensor)

Of course this listing cannot be complete. In the case of occurring errors, which are not contained in this list, please contact us directly.