



Fig. 1 variable area meter F VA Tubux M30

Application

The variable area meter F VA Tubux M30 are used to measure the volume of transparent liquids and gases passing through closed piping. The variable area meters can also be used for flow monitoring if they are equipped with one or more switching contacts. Standard scales are available for liquids with a density of 1 kg/l (62,43 lb/cu ft). The scales must be recalculated for all other media depending on the physical characteristics. The flow tube is also optionally available with a percentage or 2-mm (0.078 inch) scale.

Design and operation

The main components of the F VA Tubux variable area meters are the glass variable-area flow tube with float, the fitting and the connection parts. The flow is displayed directly on the scale present on the flow tube (e.g. in l/h) and is read at the position of the float's widest diameter (see also page 4).

Benefits

- Scales for gases and fluids
- Rugged versions with various materials
- Can be used for high pressures and temperature
- Short delivery times for standard versions.

Connection and mode of operation

For certain variable area meter sizes, the float is packed in a plastic net for transport purposes. Prior to fitting, this must be removed out of the variable area meter from the top.

The locking rod must be pulled upwards out of the variable area meter.

The variable area meter must be fitted vertically and without tension. Control elements or reductions/extensions in the pipe diameter upstream or downstream of the variable area meter have no influence on the accuracy when measuring liquids. However, when measuring gases, the variable area meter should be installed upstream of valves to prevent pulsations resulting from compression. Since variable area meters respond extremely sensitively to changes in flow, control elements should always be adjusted slowly.

The calibration has been carried out for defined media conditions. Deviations in the density, pressure or temperature of gases, or in the density or viscosity of liquids, result in measurement errors. It is essential to observe the calibration conditions. When ordering, it is therefore essential to provide data on the medium, density and viscosity at the operating temperature and pressure. With gases, it is additionally necessary to specify the exact reference point for the pressure (pressure above atmospheric, or absolute pressure).

Retrofitting of switching contacts is only possible if variable area meters with magnets are used. When using for the first time, move the float completely past the contact to permit polarization.

Float guide rod

The float guide rod prevents the float from making contact with the glass flow tube.

The option is recommended to increase the operational safety and to protect against glass breakages in the case of operating conditions such as solenoid valve control. The option is not offered in conjunction with floats with magnets and weighted PVC/ PVDF floats.

Liquids: Standard: flow tube E 4000 to E 25000
Option: flow tube C 125 and upwards

Gases: Standard: flow tube E 4000 to E 25000
Option: flow tube C 125 and upwards

Note of application

The operator of these measuring instruments is responsible for suitability, proper use and corrosion resistance of the used materials with regard to the measuring material. It must be ensured that the materials selected for the flow meter parts in contact with the medium are suitable for the used process media. The flow meter may only be used within the pressure and voltage limits specified in the operating instructions. Before replacing the measuring tubes, check that the unit is free of hazardous media and pressures. Provide a touch guard for surface temperatures of > 70°C. This touch guard must be designed in a way that the max. allowable ambient temperature on the unit is not exceeded. The flow meter meets the requirements of the PED 97/23/EG as stated in the table as follows.

Classification according to PED 97/23/EC

	Permissible media	Category
≤DN25 (G1/4 to G1)	Gases of fluid group 1 and liquids of fluid group 1	Art. 3.3
>DN25 (G1 ¼ to G2)	Gases of fluid group 1 and liquids of fluid group 1	I

Variable area meter F VA Tubux M30

Technical specification Tubux M30

Application	see page 1
Mode of operation	see page 1
Measuring principle	Float
Input	
Flow	vertically upwards
Design	
Connections	screwed gland G¼ to G2 flange DN 15/ ½" – DN 80 / 3" hose nozzle 3/8" – 2" (LW 13 -50mm)
• Build in length	see page 3
• Flow tube length	300mm (11,8 inch)
Material	
• Flow tube	Borosilicate glass
• Connection	stainless steel W.-Nr. 1.4404 / 316L PVDF PVC (see page 3)
• Float	Stainless steel W.-Nr. 1.4571 /316Ti Aluminum PVDF
• Float guide rot	Stainless steel W.-Nr. 1.4571 / 316Ti
• Gasket	Viton® FKM EPDM FFKM
• Limit	PVDF Optional Stainless steel
• Fitting	Stainless steel PVC
• Union nut	Alu Stainless Steel PVC
• optional	Shatter protection in Plexi glass up to max. 80°C Engraved scale (required for measured medium temperature >90°C / 194 °F))
Weight	
• Tubux 45 screwed gland G½ flange DN 15	approx. 0,65 kg (1,43 lb) approx. 1,91 kg (4,2 lb),
• Tubux 60 screwed gland G1 flange DN 25	approx. 1,9 kg (4,19 lb) approx. 3,7 kg (8,04 lb),
• Tubux 90 screwed gland G2 flange DN 50	approx. 3,8 kg (8,38 lb) approx. 8,7 kg (19,24 lb)

Rated operating conditions

Temperature Limits

• Flow tube	-10 to +150 °C (14 to 302 °F)
• Limit made of PVDF	-10 to +100 °C (14 to 212 °F)
• Limit made of Stainless steel	-10 to +150 °C (14 to 302 °F)
• Float material	
PVC	-10 to +50 °C (14 to 122 °F)
PVDF	-10 to +100 °C (14 to 212 °F)
Stainless steel	-10 to +150 °C (14 to 302 °F)
• Gasket	
Viton® FKM	max. 150 °C (302 °F)
EPDM	max. 150 °C (302 °F)
FFKM	max. 150 °C (302 °F)
• Connection material	
Stainless steel	-10 °C to +150 °C (14 to 302 °F)
PVC	see table below
PVDF	see table below
• Ambient temperature	-20 °C to +80 °C (-4 to 176 °F)
pressure limit for flow tube	Depending on temperature
• A 1 to A 10	max. 10 bar (145 psi) (at 20 °C)
• B 16 to B 100	max. 10 bar (145 psi) (at 20 °C)
• C125 to D 3.000	max. 10 bar (145 psi) (at 20 °C)
• E 4.000 to E 25.000	max. 8 bar (116 psi) (at 20 °C)
• Accuracy	
liquids	G 1,6 qG 50%(acc. to VDE/VDI 3513, sheet 2)
gases	G 2,5 qG 50% (acc. to VDE/VDI 3513, sheet 2)
• Measuring range	Dependent on flow tube
- for liquids	0,1 l/h to 25.000 l/h (0,00044 to 110,05 USgpm) Measuring range for water see tables on page 9 Special measuring range possible with specification of the media data and measuring range
- for gases	1 l/h to 480000 l/h (0,0006 to 282,5 scfm) Measuring range for air see tables on page 9 Special measuring range possible with specification of the media data and measuring range
• Dimension for measured variable	l/h (to flow tube D2500) m³/h (above flow tube D3000 % division markings on scale

Connections PVC und PVDF		
Medium	T[°C(F)]	P _e [bar(psi)]
Water and not abrasive liquids	20 (68)	10,0 (145)
	40 (104)	10,0 (145)
	50 (122)	2,5 (36)
abrasive liquids	20 (68)	10,0 (145)
	40 (104)	4,0 (58)
	50 (122)	1,0 (15)

P_e= eff. pressure = overpressure

Dimensions

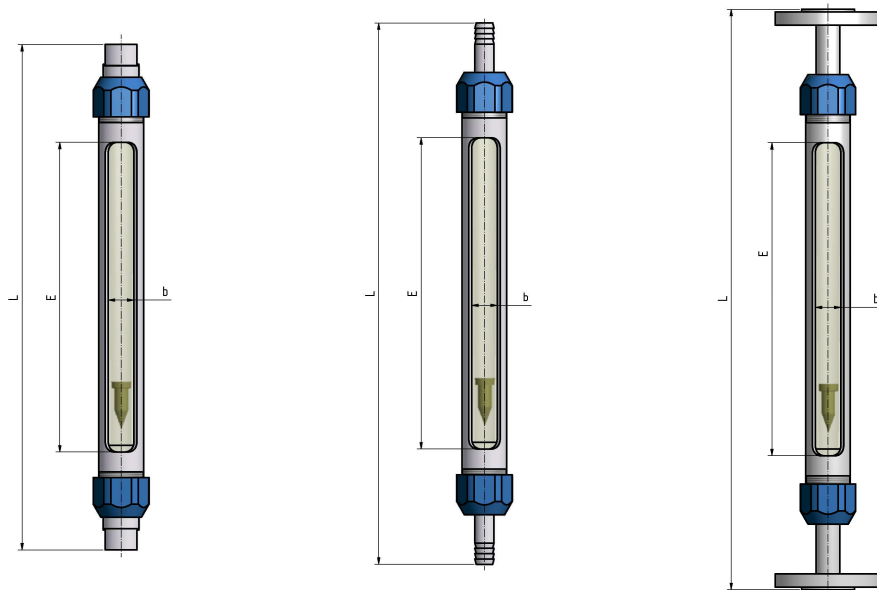

Fig. 2 F VA Tubux M30 Dimensions

Tubux M30	E in mm (inch)	b in mm (inch)	L in mm (inch)			
			screwed gland	buillt in length	hose nozzle	flange connection
45	235 (9,25)	19 (0,75)	375 (14,76)	405 ¹⁾	400 (15,75)	425 (16,73), 500 (19,69)
60	235 (9,25)	38 (1,50)	375 (14,76)	435 ¹⁾	400 (15,75) ²⁾	425 (16,73), 500 (19,69)
90	235 (9,25)	58 (2,28)	375 (14,76)	455 ¹⁾	450 (17,72)	425 (16,73), 500 (19,69)

Special build in length on request

¹⁾ order with option D01

²⁾ Build in length for hose nozzle LW38 (1 1/2") 450 mm (17,72)

Connection variants

Tubux M30	screwed gland DIN ISO 228	screwed gland NPT	hose nozzle	Flange EN 1092-1	ASME B16.5 150RF
45	G 1/4 G 3/8 G 1/2	NPT 1/4" NPT 3/8" NPT 1/2"	LW13 (3/8") LW17 (1/2")	DN 10 PN 40 DN 15 PN 40 DN 20 PN 40 DN 25 PN 40	1/2" 150RF 3/4" 150RF 1" 150RF
60	G 1/2 G 3/4 G 1	NPT 1/2" NPT 3/4" NPT 1"	LW17 (1/2") LW19 (3/4") LW25 (1") LW32 (1 1/4") LW38 (1 1/2")	DN 25 PN 40 DN 32 PN 40 DN 40 PN 40 DN 50 PN 40	1" 150RF 1 1/4" 1 1/2" 2"
90	G 1 G 1 1/4 G 1 1/2 G 2	NPT 1" NPT 1 1/4" NPT 1 1/2" NPT 2"	LW25 (1") LW32 (1 1/4") LW38 (1 1/2") LW50 (2")	DN 40 PN 40 DN 50 PN 40 DN 65 PN 16 DN 80 PN 16	1 1/2" 150RF 2" 150RF 2 1/2" 150RF 3" 150RF

Standard version are bold printed

Parts list

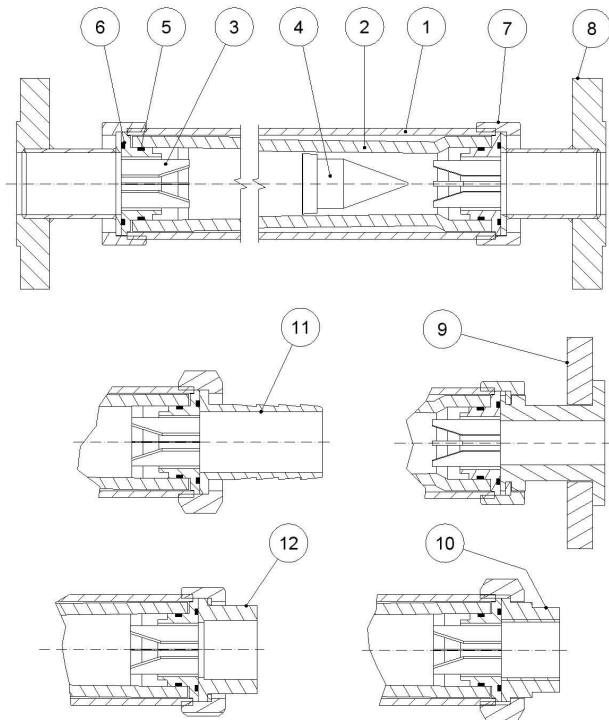

Fig. 3 Sectional drawing of FVA Tubux M30

- 1 fitting
- 2 Flow tube
- 3 limit
- 4 Float
- 5 O-Ring limit / glass
- 6 O-Ring limit / connection
- 7 Union nut
- 8 Flange connection
- 9 Flange connection in plastic
- 10 Female thread connection
- 11 Hose nozzle connection
- 12 Solvent-cemented connection

selection of float/ reading edge

There are three versions of floats:

- Non-guided float
- Guided float
- Viscosity-compensated float.

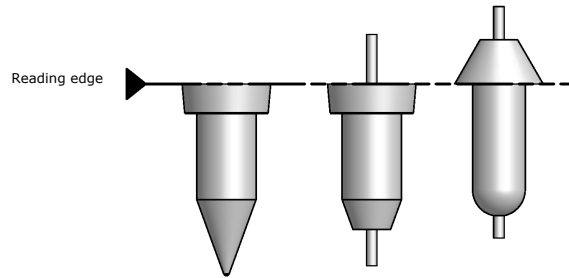

Fig. 4 Float version

Use of the viscosity-compensated float is necessary above the following viscosities:

Flow tube	mPa·s (cP)
C 125 to C 500	≥ 3
D 650 to D 3000	≥ 5
E 4000 to F 10000	≥ 8

Technical data contacts K17

The K17 bistable magnetic contact assemblies indicate the position of the float. In this way, measurement values are indicated without contact or feedback.

Special features:

- Bistable behavior
- High agitation resistance
- Switching without feedback
- No mutual influencing between the contacts
- Switching with almost no inertia
- Simple plug connection

The bistable contact assembly consists of a contact spring set sealed in a glass tube filled with protective gas.

Three contacts can be selected:

- K 17 A: contact closes when the limit is fallen below
- K 17 B: contact closes when the limit is exceeded

Switching principle	Magnetic contact unit, bistabile
housing/ plug	PP/PA 6
Contact material	Rhodium
Protection class	IP65
Ambient temperature	-20 to +80 °C / -4 to 176 °F
max. switching frequency	5/min
max. rating	AC 250 V/0,5 A/10 VA DC 250 V/0,5 A/5 W

Important: The maximum switching capacity and the maximum permissible peak activation current may not be exceeded; otherwise a welding effect arises at the contact studs causing them to bond together.

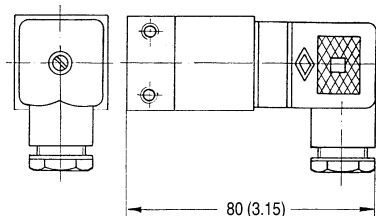

Fig. 5 Contact K17, Dimension in mm (inch)

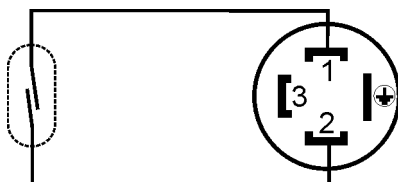

Fig. 6 electrical connection K17

Assembly of the connection cable onto the plug connection:

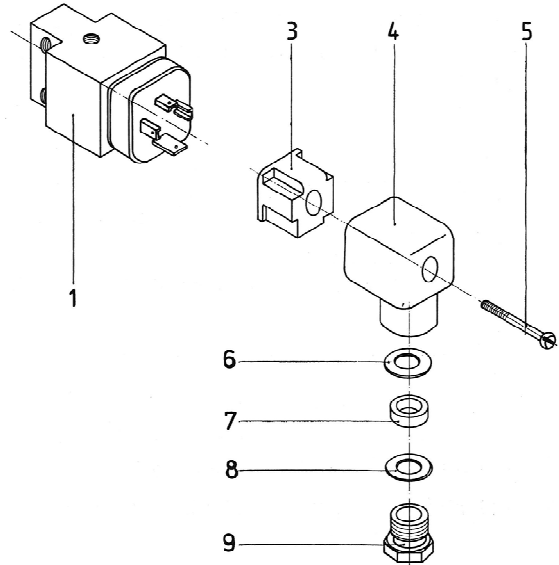

Fig. 7 Exploded view of contact K17

1. Loosen cable screw connection (9) and remove the seals (8, 7, 6)
2. Take out of the cover
3. Loosen the locking screw (5) and pull the cover (4) with element (3) off the contact housing (1).
4. Pull the screw (5) and insert element (3) out of the cover (4).
5. Feed the connection cable through the cable screw connection (9) and the seals (8, 7, 6) into the cover (4) and fasten to terminals 1 and 2 of the insert element.
6. Assembly of the plug connection takes place in the reverse order of the steps described under 1. to 3. The insert element can be rotated freely by 90° so that the cable runs down, up, right or left after connecting to the K17.

Commissioning:

During commissioning by the user, we recommend running the float of the device past the contact once or, similarly, the contact past the float. This will ensure the correct starting position of the contact.

Contact fastening K17:

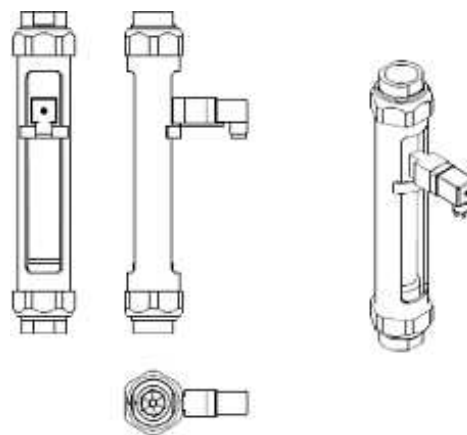

Fig. 8 Contact fastening of K17 to Tubux M30

Technical data contact K33

The magnetic protective gas contact is used in connection with measurement devices in situations where electrical circuits must be opened or closed at specific measurement values.

Housing	Alu
Contact material	AgPd
Protection class	IP54
Switching voltage	[V~] 220 [V=] 250
Continuous current	[A] 1.5
Switching capacity	[V~] 220 max.150 VA [V=] 250 max.100W
Switching contact resistance	[Ω] 0.2 Ohm
Insulation resistance	[Ω] 50 M Ohm
Breakdown voltage	[V] 1150
Mech. service life	10 ⁸ switch operations
Max. switching frequency	7200 /h
Electrical connection	Rectangular plug connector, type A (EN 175301-803)

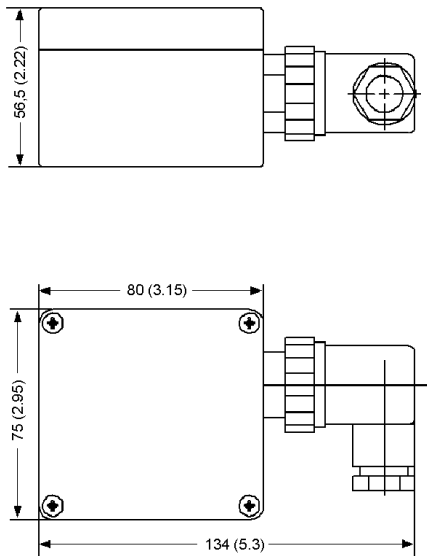

Fig. 9 ChangerK33, Dimension in mm (inch)

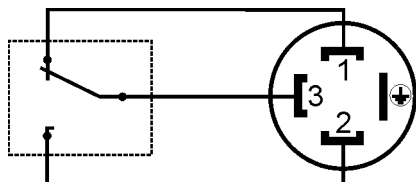

Fig. 10 electrical connection K33

Design and operating principle of protective gas contacts

Applications

The special advantage of this switch lies in the gas-tight encapsulation of the contacts, which prevents spark generation. This eliminates the risk of a gas explosion from switching sparks and in many cases makes expensive explosion protection measures unnecessary.

Operating principle

The contact springs of silver palladium are located within a glass tube filled with protective gas (fused in gas-tight). The middle, movable contact arm is pulled by a holding magnet affixed to the glass tube and held in the resting position. A tilting magnet on a toe bearing can be turned by an actuation magnet so that one of its poles is opposite the holding magnet. The stronger magnetic field of the tilting magnet pulls the contact arm, resulting in a switching operation. If the tilting magnet is turned back to its initial position by the actuation magnet, the contact arm returns to its original position due to the attractive force of the holding magnet. Since it is a changeover contact, it is possible to use both a circuit opening connection and a circuit closing connection.

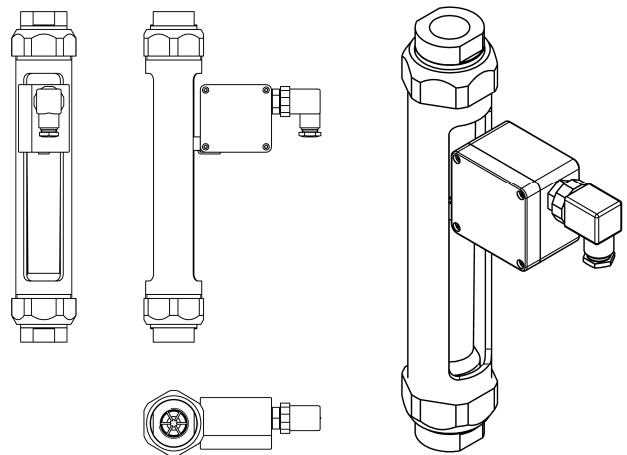

Fig. 11 Contact fastening of K33 to Tubux M30

Technical data contact K33i

The inductive switch contact K33i is used in particular when an electrical circuit must be opened or closed at specific measurement values in areas with gas, vapor or mist at risk to explosion.

Housing	Aluminum
Switching element function	Break contact
Output polarity	NAMUR (DIN EN 60947-5-6)
Protection class	IP54
Rated voltage U_0	[V] 8
Operating voltage U_B	[V] 5 ... 25V
Max. switching frequency	3000 Hz
Electrical connection	Rectangular plug connector, type A (EN 175301-803)

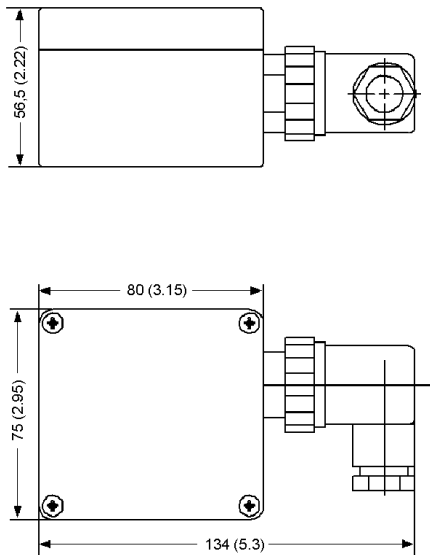

Fig. 12 Inductive contact K33i, dimension in mm (inch)

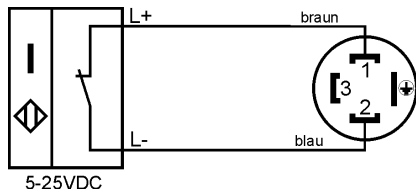

Fig. 13 electrical connection K33i

Design and operating principle of inductive slot proximity sensors

Application

The special advantage of the inductive slot proximity switch used lies in the sealed joint welding of the housing body and housing lid as well as the cavity-free casting of the sensors under a vacuum, which prevents the entrance of moisture. The protection class of the sensor is IP 68.

Thanks to the intrinsically safe design of the sensor, use in areas at risk to explosion is possible.

Operating principle

A control lug is fastened to the magnet mount of a tilting magnet on a toe bearing such that, depending on the position of the tilting magnet, the free end of the control lug either does or does not protrude into the slot of an inductive sensor.

The tilting magnet can be turned with an actuation magnet that brushes past the switch housing.

The dampening of the internal magnetic field of the sensor caused by the control lug protruding into the slot is detected by the sensor and converted into an output signal according to the NAMUR standard (DIN EN 60947-5-6).

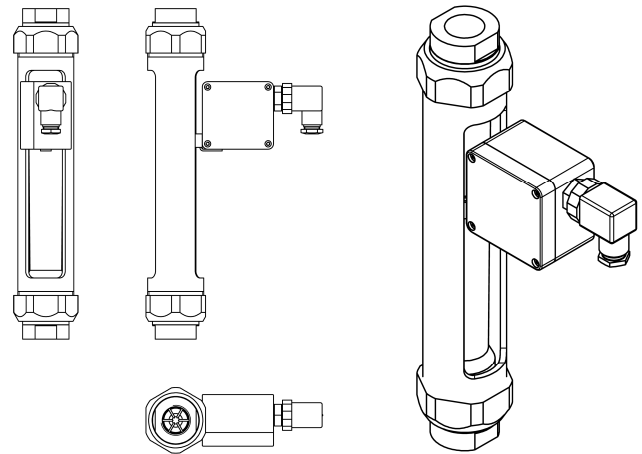

Fig. 14 Contact fastening of K33 i to Tubux M30

Variable area meter F VA Tubux M30

Measuring ranges liquids

Standard-measuring range for liquids ($\rho = 1\text{kg/l (62,43 lb/cu.ft, viscosity 1 mPa.s (1cp)) (dynamic range 1:10)$)

Tubux fitting	flow tube	pressure loss		max. Measuring range for the selected float							
		mbar	psi	Standard float		with Magnet		viscosity – compensated		PVDF weighted PVDF weighted with magnet from flow tube C 125	
				Material No. 1.4571 l/h	316Ti Usgpm	Material No. 1.4571 l/h	316Ti Usgpm	Material No. 1.4571 l/h	316Ti Usgpm	Material No. 1.4571 l/h	316Ti Usgpm
45	A 1	10	0,145	1	0,0044	-	-	-	-	-	-
	A 3			3	0,013	-	-	-	-	-	-
	A 5			5	0,022	-	-	-	-	-	-
	A 10			10	0,044	-	-	-	-	-	-
	B 16			16	0,070	-	-	-	-	7	0,031
	B 25			25	0,11	-	-	-	-	11	0,048
	B 30			30	0,132	-	-	-	-	11	0,048
	B 40			40	0,176	-	-	-	-	15	0,066
	B 50			50	0,22	-	-	-	-	20	0,088
	B 65			65	0,29	-	-	-	-	25	0,11
	B 80	80	0,35	-	-	-	-	32	0,14		
	B 100	100	0,44	-	-	-	-	40	0,18		
	C 125	20	0,29	125	0,55	120	0,53	100*	0,44*	65	0,29
	C 160			160	0,70	150	0,66	125*	0,55*	90	0,40
	C 200			200	0,88	180	0,79	160*	0,70*	110	0,48
C 250	250			1,10	240	1,06	200*	0,88*	140	0,62	
C 315	40	0,58	315	1,39	300	1,32	240*	1,06*	175	0,77	
C 400			400	1,76	360	1,59	300*	1,32*	220	0,97	
C 500			500	2,20	480	2,11	360*	1,59*	250	1,10	
D 650			19	0,28	650	2,86	600	2,64	400*	1,76*	500
D 800	800	3,52			750	3,30	500*	2,20*	600	2,64	
D 1000	1000	4,40			950	4,18	600*	2,64*	750	3,30	
D 1250	1250	5,50			1200	5,30	750*	3,30*	1000	4,40	
D 1600	24	0,35	1600	7,00	1500	6,60	1000*	4,40*	1250	5,50	
D 2000			2000	8,80	1800	7,90	1200*	5,30*	1600	7,00	
D 2500	33	0,48	2500	11,0	2400	10,6	1400*	6,20*	2000	8,80	
D 3000			3000	13,2	2800	12,3	1800*	7,90*	2400	10,6	
E 4000	25	0,36	4000*	17,6*	3800*	16,7*	2500*	11,1*	3200	14,0	
E 5000			5000*	22,6*	4800*	21,1*	3000*	13,0*	3800	16,7	
E 6500			6500*	28,6*	6400*	28,2*	4000*	17,6*	5000	22,0	
E 8000			8000*	35,2*	7500*	33,0*	4500*	19,8*	6400	28,2	
E 10000			10000*	44,0*	9500*	41,8*	5500*	24,2*	7500	33,0	
E 12500			12500¹⁾*	55,0 ¹⁾ *	12000 ¹⁾ *	52,8 ¹⁾ *	-	-	-	-	
E 16000			16000²⁾*	70,4 ²⁾ *	16000 ²⁾ *	70,4 ²⁾ *	-	-	-	-	
E 20000			20000³⁾*	88,0 ³⁾ *	19000 ³⁾ *	83,6 ³⁾ *	-	-	-	-	
E 25000	25000³⁾*	110,1 ³⁾ *	24000 ³⁾ *	105,7 ³⁾ *	-	-	-	-			

Remarks: *Guided float
Standard versions are bold printed
1) Dynamic range 1:6
2) Dynamic range 1:4
3) Dynamic range 1:3

Measuring ranges air

Standard measuring range for air ($\rho_{\text{abs}} = 1.013 \text{ bar (14.69 psi)}$ at $T = 0^\circ\text{C (32}^\circ\text{F)}$, $\rho = 1.293 \text{ kg/m}^3$, $v = 0.0181 \text{ mPa.s}$) (dynamic range 1:10)

Tubux fitting	Flow tube	pressure loss		max. measuring range for the select float							
		mbar	psi	Aluminium mat. No. 3.1645		Aluminium mat. No. 3.1645 with Magnet		PVDF		PVDF with Magnet	
				l/h	scfm	l/h	scfm	l/h	scfm	l/h	scfm
45	A 1	4	0,058	16	0,0094	-	-	10	0,0059	-	-
	A 3			50	0,029	-	-	25	0,015	-	-
	A 5			80	0,047	-	-	50	0,029	-	-
	A 10			160	0,094	-	-	80	0,047	-	-
	B 16			300	0,177	-	-	230	0,135	-	-
	B 25			450	0,265	-	-	300	0,177	-	-
	B 30			500	0,294	-	-	360	0,212	-	-
	B 40			650	0,383	-	-	500	0,294	-	-
	B 50			800	0,471	-	-	650	0,383	-	-
	B 65			1100	0,647	-	-	800	0,471	-	-
	B 80	1400	0,824	-	-	1000	0,589	-	-		
	B 100	1600	0,942	-	-	1250	0,736	-	-		
	C 125	6,5	0,094	2000	1,18	2500	1,47	1500	0,88	2200	1,29
	C 160			3000	1,77	3200	1,88	2000	1,18	3000	1,77
C 200	3600			2,12	4000	2,35	2500	1,47	3600	2,12	
C 250	4000			2,35	5000	2,94	3000	1,77	4500	2,65	
C 315	15	0,218	5000	2,94	6400	3,77	3600	2,12	6000	3,53	
C 400			6400	3,77	8000	4,71	5000	2,94	7000	4,12	
C 500			8000	4,71	10000	5,89	5500	3,24	9500	5,59	
D 650			7	0,102	10000	5,89	12000	7,06	8000	4,71	10000
D 800	13000	7,65			15000	8,83	9000	5,30	13000	7,65	
D 1000	16000	9,42			20000	11,77	12000	7,06	16000	9,42	
D 1250	20000	11,77			24000	14,13	15000	8,83	20000	11,77	
D 1600	9	0,131	28000	16,48	32000	18,83	20000	11,77	28000	16,48	
D 2000			36000	21,19	40000	23,54	25000	14,71	36000	21,18	
D 2500	12	0,174	40000	23,54	50000	29,43	30000	17,66	40000	23,54	
D 3000			50000	29,43	60000	35,31	36000	21,19	50000	29,43	
E 4000	10	0,145	64000*	37,67*	75000*	44,14*	50000	29,43	64000	37,67	
E 5000			80000*	47,09*	100000*	58,86*	65000	38,26	80000	47,09	
E 6500			100000*	58,86*	125000*	73,57*	80000	47,09	100000	58,86	
E 8000			140000*	82,40*	150000*	88,29*	100000	58,86	140000	82,40	
E 10000			160000*	94,17*	180000*	105,9*	125000	73,57	160000	94,17	
E 12500			200000¹⁾*	117,7 ¹⁾ *	220000 ¹⁾ *	129,5 ¹⁾ *	150000	88,3	-	-	
E 16000			280000²⁾*	164,8 ²⁾ *	300000 ²⁾ *	176,5 ²⁾ *	190000	111,8	-	-	
E 20000			350000³⁾*	206,0 ³⁾ *	400000 ³⁾ *	235,4 ³⁾ *	240000	141,3	-	-	
E 25000	430000³⁾*	253,0 ³⁾ *	480000 ³⁾ *	253,0 ³⁾ *	300000	176,6	-	-			

Remarks: *Guided float
Standard versions are bold printed
1) Dynamic range 1:6
2) Dynamic range 1:4
3) Dynamic range 1:3

Ordering data Tubux M30 - 60 for liquids – Measuring range from 40 to 3000 l/h

7ME5812- 4		-	
Flow tube material	Float / Measuring range		
D 650	mat. No. 1.4571 / Qv 65 - 650 l/h	BB	0
	mat. No. 1.4571 / guided / Qv 65 - 650 l/h	BB	2
	mat. No. 1.4571/with magnet/Qv 60-600 l/h	BB	1
	PVDF, weighted / Qv 50 - 500 l/h	BE	0
	PVDF, weighted/with magnet/Qv 50-500 l/h	BE	1
	mat. No. 1.4571/SV/guided/Qv 40-400 l/h	BC	2
D 800	mat. No. 1.4571 / Qv 80 - 800 l/h	CB	0
	mat. No. 1.4571 / guided / Qv 80 - 800 l/h	CB	2
	mat. No. 1.4571/with magnet/Qv 75-750 l/h	CB	1
	PVDF, weighted / Qv 60 - 600 l/h	CE	0
	PVDF, weighted/with magnet/Qv 60-600 l/h	CE	1
	mat. No. 1.4571/SV/guided/Qv 50-500 l/h	CC	2
D 1000	mat. No. 1.4571 / Qv 100 - 1000 l/h	DB	0
	mat. No. 1.4571 / quided / Qv 100 - 1000 l/h	DB	2
	mat. No. 1.4571/with magnet/Qv 95-950 l/h	DB	1
	PVDF, weighted / Qv 75 - 750 l/h	DE	0
	PVDF, weighted/with magnet/Qv 75-750 l/h	DE	1
	mat. No. 1.4571/SV / guided/Qv 60-600 l/h	DC	2
D 1250	mat. No. 1.4571 / Qv 125 - 1250 l/h	EB	0
	mat. No. 1.4571 / guided / Qv 125 - 1250 l/h	EB	2
	mat. No. 1.4571/with magnet/Qv 120-1200 l/h	EB	1
	PVDF, weighted / Qv 100,0 - 1000 l/h	EE	0
	PVDF, weighted/with magnet/Qv 100-1000 l/h	EE	1
	mat. No. 1.4571/SV/guided/Qv 75-750 l/h	EC	2
D 1600	mat. No. 1.4571 / Qv 160 - 1600 l/h	FB	0
	mat. No. 1.4571 / guided / Qv 160 - 1600 l/h	FB	2
	mat. No. 1.4571/with magnet/Qv 150 - 1500 l/h	FB	1
	PVDF, weighted / Qv 125 - 1250 l/h	FE	0
	PVDF, weighted/with magnet/Qv 125 - 1250 l/h	FE	1
	mat. No. 1.4571/SV/guided/Qv 100 - 1000 l/h	FC	2
D 2000	mat. No. 1.4571 / Qv 200 - 2000 l/h	GB	0
	mat. No. 1.4571 / guided / Qv 200 - 2000 l/h	GB	2
	mat. No. 1.4571/with magnet/Qv 180-1800 l/h	GB	1
	PVDF, weighted / Qv 160 - 1600 l/h	GE	0
	PVDF, weighted/with magnet/Qv 160-1600 l/h	GE	1
	mat. No. 1.4571/ SV/guided/Qv 120-1200 l/h	GC	2
D 2500	mat. No. 1.4571 / Qv 250 - 2500 l/h	HB	0
	mat. No. 1.4571 / quided / Qv 250 - 2500 l/h	HB	2
	mat. No. 1.4571/with magnet/Qv 240-2400 l/h	HB	1
	PVDF, weighted / Qv 200 - 2000 l/h	HE	0
	PVDF, weighted/with magnet/Qv 200-2000 l/h	HE	1
	mat. No. 1.4571/SV/guided/Qv 140-1400 l/h	HC	2
D 3000	mat. No. 1.4571 / Qv 300 - 3000 l/h	JB	0
	mat. No. 1.4571 / guided / Qv 300 - 3000 l/h	JB	2
	mat. No. 1.4571/with magnet/Qv 280-2800 l/h	JB	1
	PVDF, weighted / Qv 240 - 2400 l/h	JE	0
	PVDF, weighted/with magnet/Qv 240-2400 l/h	JE	1
	mat. No. 1.4571/SV/guided/Qv 180-1800 l/h	JC	2
Design variant			
	Fitting in stainless steel, union nut in aluminum		1
	Fitting in stainless steel, union nut in stainless steel		2
	Fitting in PVC, union nut in PVC, connection part in PVC		3
Gasket			
	Viton® FKM		4
	EPDM		5
	FFKM		8

7ME5812- 4		-	
Contacts			
without			0
Contact K17/A (closes when value falls below limit)			1
Contact K17/B (closes when value exceeds limit)			2
two contacts K17/A			3
two contacts K17/B			4
contact K17/A and contact K17/B			6
contact K 33 changer			5
contact K 33i (inductive contact)			7
Connection PVC adhesive bushing			
PVC adhesive bushing 32 (DN25)			A A
Connection female thread DIN ISO 228			
PVDF			C
stainless steel			D
	G 1/2		D
	G 3/4		E
	G 1		F
Connection female thread NPT			
PVDF			F
stainless steel			G
	NPT 1/2"		D
	NPT 3/4"		E
	NPT 1"		F
Hose nozzle connection			
PVDF			H
stainless steel			J
	LW 13 (1/2")		C
	LW 19 (3/4")		D
	LW 25 (1")		E
	LW 32 (1 1/4")		F
	LW 38 (1 1/2")		G
Connection flange EN 1092-1			
PVDF build in length 425 mm			K
PVDF build in length 500 mm			L
stainless steel build in length 425 mm			M
stainless steel build in length 500 mm			N
	DN 25 PN 40		D
	DN 32 PN 40		E
	DN 40 PN 40		F
	DN 50 PN 40		G
Connection flange ANSI B16.5			
PVDF build in length 425 mm			P
PVDF build in length 500 mm			Q
stainless steel build in length 425 mm			R
stainless steel build in length 500 mm			S
	1" ANSI 150 RF		D
	1 1/4" ANSI 150 RF		E
	1 1/2" ANSI 150 RF		F
	2" ANSI 150 RF		G
Further design			
Please add "-Z" to order No. And specify order code			
Y01	Measured medium, always required, enter in plain text: Medium, measuring range, unit, density, density unit, viscosity, viscosity unit, oper. temp., operating pressure		
Y02	With engraved scale (>90°C /194°F)		
Y04	Silicone-free design		
Y03	Special scale markings (measuring precision 1%)		
B06	With calibration certificate		
B11	Labeling of the type plate in English		
C15	ATEX certification		
Y17	TAG plate		
C05	Factory certification 2.1 as per EN10204		
C07	Pressure test as per EN10204		
C09	Leak test as per EN10204		
C12	Material certificate for the stainless steel connection parts		
Y07	Cleaning		
S05	Shatter protection to max. 80 °C		
S06	Stainless steel stop		
D01	Built in length 435mm		

Variable area meter F VA TUBUX M30

Ordering data Tubux M30 - 90 for liquids – Measuring range from 250 to 25000 l/h

		7ME5812- 5		-	
Measuring cone					
Float material / measuring range					
E 4000	mat. No. 1.4571 / guided / Qv 400 - 4000 l/h	B B			0
	mat. No. 1.4571/with magnet/Qv 380-3800 l/h	B B			1
	PVDF, weighted / Qv 320 - 3200 l/h	B E			0
	PVDF, weighted/with magnet/Qv 320-3200 l/h	B E			1
	mat. No. 1.4571/SV/guided/Qv 250-2500 l/h	B C			2
E 5000	mat. No. 1.4571 / guided / Qv 500 - 5000 l/h	C B			0
	mat. No. 1.4571/with magnet/Qv 480-4800 l/h	C B			1
	PVDF, weighted / Qv 380 - 3800 l/h	C E			0
	PVDF, weighted/with magnet/Qv 380-3800 l/h	C E			1
	mat. No. 1.4571/SV/guided/Qv 300-3000 l/h	C C			2
E 6500	mat. No. 1.4571 / guided / Qv 650 - 6500 l/h	D B			0
	mat. No. 1.4571//with magnet/Qv 640-6400 l/h	D B			1
	PVDF, weighted / Qv 500 - 5000 l/h	D E			0
	PVDF, weighted/with magnet/Qv 500-5000 l/h	D E			1
	mat. No. 1.4571/SV/guided/Qv 400-4000 l/h	D C			2
E 8000	mat. No. 1.4571 / guided / Qv 800 - 8000 l/h	E B			0
	mat. No. 1.4571/with magnet/Qv 750-7500 l/h	E B			1
	PVDF, weighted / Qv 640 - 6400 l/h	E E			0
	PVDF, weighted/with magnet/Qv 640-6400 l/h	E E			1
	mat. No. 1.4571/SV/guided/Qv 450-4500 l/h	E C			2
E 10000	mat. No. 1.4571/guided/Qv 1000-10000 l/h	F B			0
	mat. No. 1.4571/with magnet/Qv 950-9500 l/h	F B			1
	PVDF, weighted / Qv 750 - 7500 l/h	F E			0
	PVDF, weighted/with magnet/Qv 750-7500 l/h	F E			1
	mat. No. 1.4571/SV/guided/Qv 550-5500 l/h	F C			2
E 12500	mat. No. 1.4571/guided/Qv 2083,3-12500 l/h	G B			0
	mat. No. 1.4571/with magnet/Qv 2000-12000 l/h	G B			1
E 16000	mat. No. 1.4571/guided/Qv 4000-16000 l/h	H B			0
	mat. No. 1.4571/with magnet/Qv 4000-16000 l/h	H B			1
E 20000	mat. No. 1.4571/guided/Qv 6666,7-20000 l/h	J B			0
	mat. No. 1.4571/with magnet/Qv 6333,3-19000 l/h	J B			1
E 25000	mat. No. 1.4571/guided/Qv 8333,3-25000 l/h	K B			0
	mat. No. 1.4571/with magnet/Qv 8000-24000 l/h	K B			1
Design variant					
	Fitting in stainless steel, union nut in aluminium				1
	Fitting in stainless steel, union nut in stainless steel				2
	Fitting in PVC, union nut in PVC, connection part in PVC				3
Gasket					
	Viton® FKM				4
	EPDM				5
	FFKM				8

		7ME5812- 5		-	
Contacts					
	without				0
	Contact K17/A (closes when value falls below limit)				1
	Contact K17/B (closes when value exceeds limit)				2
	two contacts K17/A				3
	two contacts K17/B				4
	contact K17/A and contact K17/B				6
	contact K 33 changer				5
	contact K 33i (inductive contact)				7
Connection PVC adhesive bushing					
	PVC adhesive bushing 63 (DN50)				A A
Connection female thread DIN ISO 228					
	PVDF				C
	Stainless steel				D
	G 1				F
	G 1 1/4				G
	G 1 1/2				H
	G 2				J
Connection female thread NPT					
	PVDF				F
	stainless steel				G
	NPT 1"				F
	NPT 1 1/4"				G
	NPT 1 1/2"				H
	NPT 2"				J
Hose nozzle connection					
	PVDF				H
	stainless steel				J
	LW 25 (1")				E
	LW 32 (1 1/4")				F
	LW 38 (1 1/2")				G
	LW 50 (2")				H
Connection flange EN 1092-1					
	PVDF build in length 425 mm				K
	PVDF build in length 500 mm				L
	stainless steel build in length 425 mm				M
	stain less steel build in length 500 mm				N
	DN 40 PN 40				F
	DN 50 PN 40				G
	DN 65 PN 16				H
	DN 80 PN 16				J
Connection flange ANSI B16.5					
	PVDF build in length 425 mm				P
	PVDF build in length 500 mm				Q
	stainless steel build in length 425 mm				R
	stainless steel build in length 500 mm				S
	1 1/2" ANSI 150 RF				F
	2" ANSI 150 RF				G
	2 1/2" ANSI 150 RF				H
	3" ANSI 150 RF				J
Further design					
Please add "-Z" to order No. And specify order code					
Y01	Measured medium, always required, enter in plain text: Medium, measuring range, unit, density, density unit, viscosity, viscosity unit, oper. temp., operating pressure				
Y02	With engraved scale (>90°C /194°F)				
Y04	Silicone-free design				
Y03	Special scale markings (measuring precision 1%)				
B06	With calibration certificate				
B11	Labeling of the type plate in English				
C15	ATEX certification				
Y17	TAG plate				
C05	Factory certification 2.1 as per EN10204				
C07	Pressure test as per EN10204				
C09	Leak test as per EN10204				
C12	Material certificate for the stainless steel connection parts				
Y07	Cleaning				
S05	Shatter protection to max. 80 °C				
S06	Stainless steel stop				
D01	built in length 450mm				

Variable area meter F VA TUBUX M30

Ordering data Tubux M30 - 60 for gases – Measuring range from 800 to 60000 l/h

		7ME5812- 4	
Measuring cone			
Float material / measuring range			
D 650	Aluminium / Qn 1000 - 10000 l/h	B F	0
	Aluminium / guided / Qn 1000 - 10000 l/h	B F	2
	Aluminium / with magnet / Qn 1200 - 12000 l/h	B F	1
	PVDF/ Qn 800 - 8000 l/h	B H	0
	PVDF/ with magnet / Qn 1000 - 10000 l/h	B H	1
D 800	Aluminium / Qn 1300 - 13000 l/h	C F	0
	Aluminium / guided / Qn 1300 - 13000 l/h	C F	2
	Aluminium / with magnet / Qn 1500 - 15000 l/h	C F	1
	PVDF/ Qn 900 - 9000 l/h	C H	0
	PVDF/ with magnet / Qn 1300 - 13000 l/h	C H	1
D 1000	Aluminium / Qn 1600 - 16000 l/h	D F	0
	Aluminium / guided / Qn 1600 - 16000 l/h	D F	2
	Aluminium / with magnet / Qn 2000 - 20000 l/h	D F	1
	PVDF/ Qn 1200 - 12000 l/h	D H	0
	PVDF/ with magnet / Qn 1600 - 16000 l/h	D H	1
D 1250	Aluminium / Qn 2000 - 20000 l/h	E F	0
	Aluminium / guided / Qn 2000 - 20000 l/h	E F	2
	Aluminium / with magnet / Qn 2400 - 24000 l/h	E F	1
	PVDF/ Qn 1500 - 15000 l/h	E H	0
	PVDF/ with magnet / Qn 2000 - 20000 l/h	E H	1
D 1600	Aluminium / Qn 2800 - 28000 l/h	F F	0
	Aluminium / guided / Qn 2800 - 28000 l/h	F F	2
	Aluminium / with magnet / Qn 3200 - 32000 l/h	F F	1
	PVDF/ Qn 2000 - 20000 l/h	F H	0
	PVDF/ with magnet / Qn 2800 - 28000 l/h	F H	1
D 2000	Aluminium / Qn 3600 - 36000 l/h	G F	0
	Aluminium / guided / Qn 3600 - 36000 l/h	G F	2
	Aluminium / with magnet / Qn 4000 - 40000 l/h	G F	1
	PVDF/ Qn 2500 - 25000 l/h	G H	0
	PVDF/ with magnet / Qn 3600 - 36000 l/h	G H	1
D 2500	Aluminium / Qn 4000 - 40000 l/h	H F	0
	Aluminium / guided / Qn 4000 - 40000 l/h	H F	2
	Aluminium / with magnet / Qn 5000 - 50000 l/h	H F	1
	PVDF/ Qn 3000 - 30000 l/h	H H	0
	PVDF/ with magnet / Qn 4000 - 40000 l/h	H H	1
D 3000	Aluminium / Qn 5000 - 50000 l/h	J F	0
	Aluminium / guided / Qn 5000 - 50000 l/h	J F	2
	Aluminium / with magnet / Qn 6000 - 60000 l/h	J F	1
	PVDF/ Qn 3600 - 36000 l/h	J H	0
	PVDF/ with magnet / Qn 5000 - 50000 l/h	J H	1
Design variant			
	Fitting in stainless steel, union nut in aluminium		1
	Fitting in stainless steel, union nut in stainless steel		2
	Fitting in PVC, union nut in PVC, connection part in PVC		3
Gasket material			

		7ME5812- 4	
Contacts			
	without		0
	Contact K17/A (closes when value falls below limit)		1
	Contact K17/B (closes when value exceeds limit)		2
	two contacts K17/A		3
	two contacts K17/B		4
	contact K17/A and contact K17/B		5
	contact K 33 changer		6
	contact K 33i (inductive contact)		7
Connection PVC adhesive bushing			
	PVC adhesive bushing 32 (DN25)		A A
Connection female thread DIN ISO 228			
	PVDF		C
	stainless steel		D
	G 1/2		D
	G 3/4		E
	G 1		F
Connection female thread NPT			
	PVDF		F
	stainless steel		G
	NPT 1/2"		D
	NPT 3/4"		E
	NPT 1"		F
Hose nozzle connection			
	PVDF		H
	stainless steel		J
	LW 13 (1/2")		C
	LW 19 (3/4")		D
	LW 25 (1")		E
	LW 32 (1 1/4")		F
	LW 38 (1 1/2")		G
Connection flange EN 1092-1			
	PVDF build in length 425 mm		K
	PVDF build in length 500 mm		L
	stainless steel build in length 425 mm		M
	stainless steel build in length 500 mm		N
	DN 25 PN 40		D
	DN 32 PN 40		E
	DN 40 PN 40		F
	DN 50 PN 40		G
Connection flange ANSI B16.5			
	PVDF build in length 425 mm		P
	PVDF build in length 500 mm		Q
	stainless steel build in length 425 mm		R
	stainless steel build in length 500 mm		S
	1" ANSI 150 RF		D
	1 1/4" ANSI 150 RF		E
	1 1/2" ANSI 150 RF		F
	2" ANSI 150 RF		G
Further design			
Please add "-Z" to order No. And specify order code			
Y01	Measured medium, always required, enter in plain text: Medium, measuring range, unit, density, density unit, viscosity, viscosity unit, oper. temp., operating pressure		
Y02	With engraved scale (>90°C /194°F)		
Y04	Silicone-free design		
Y03	Special scale markings (measuring precision 1%)		
B06	With calibration certificate		
B11	Labeling of the type plate in English		
C15	ATEX certification		
Y17	TAG plate		
C05	Factory certification 2.1 as per EN10204		
C07	Pressure test as per EN10204		
C09	Leak test as per EN10204		
C12	Material certificate for the stainless steel connection parts		
Y07	Cleaning		
S05	Shatter protection to max. 80 °C		
S06	Stainless steel stop		
D01	Built in length 435mm		

Ordering data Tubux M30 - 90 for gases – Measuring range from 5000 to 480000 l/h

7ME5812- 5				
Measuring cone				
Float material / measuring range				
E 4000	Aluminium / guided / Qn 6400 - 64000 l/h	B	F	0
	Aluminium / with magnet / Qn 7500 - 75000 l/h	B	F	1
	PVDF / Qn 5000 - 50000 l/h	B	H	0
	PVDF / with magnet / Qn 6400 - 64000 l/h	B	H	1
E 5000	Aluminium / guided / Qn 8000 - 80000 l/h	C	F	0
	Aluminium / with magnet / Qn 10000 - 100000 l/h	C	F	1
	PVDF / Qn 6500 - 65000 l/h	C	G	0
	PVDF / with magnet / Qn 8000 - 80000 l/h	C	H	1
E 6500	Aluminium / guided / Qn 10000 - 100000 l/h	D	F	0
	Aluminium / with magnet / Qn 12500 - 125000 l/h	D	F	1
	PVDF / Qn 8000 - 80000 l/h	D	G	0
	PVDF / with magnet / Qn 10000 - 100000 l/h	D	H	1
E 8000	Aluminium / guided / Qn 14000 - 140000 l/h	E	F	0
	Aluminium / with magnet / Qn 15000 - 150000 l/h	E	F	1
	PVDF / Qn 10000 - 100000 l/h	E	G	0
	PVDF / with magnet / Qn 14000 - 140000 l/h	E	H	1
E 10000	Aluminium / guided / Qn 16000 - 160000 l/h	F	F	0
	Aluminium / with magnet / Qn 18000 - 180000 l/h	F	F	1
	PVDF / Qn 12500 - 125000 l/h	F	G	0
	PVDF / with magnet / Qn 16000 - 160000 l/h	F	H	1
E 12500	Aluminium / guided / Qn 33333,3 - 200000 l/h	G	F	0
	Aluminium / with magnet / Qn 36666,7 - 220000 l/h	G	F	1
	PVDF / Qn 25000 - 150000 l/h	G	H	0
E 16000	Aluminium / guided / Qn 70000 - 280000 l/h	H	F	0
	Aluminium / with magnet / Qn 75000 - 300000 l/h	H	F	1
	PVDF / Qn 47500 - 190000 l/h	H	H	0
E 20000	Aluminium / guided / Qn 11666,7 - 350000 l/h	J	F	0
	Aluminium / with magnet / Qn 133333,3 - 400000 l/h	J	F	1
	PVDF / Qn 80000 - 240000 l/h	J	H	0
E 25000	Aluminium / guided / Qn 143333,3 - 430000 l/h	K	F	0
	Aluminium / with magnet / Qn 160000 - 480000 l/h	K	F	1
	PVDF / Qn 100000 - 300000 l/h	K	H	0
Design variant				
	Fitting in stainless steel, union nut in aluminium			1
	Fitting in stainless steel, union nut in stainless steel			2
	Fitting in PVC, union nut in PVC, connection part in PVC			3
Gasket material				
	Viton® FKM			4
	EPDM			5
	FFKM			8

7ME5812- 5				
Contacts				
	without			0
	Contact K17/A (closes when value falls below limit)			1
	Contact K17/B (closes when value exceeds limit)			2
	two contacts K17/A			3
	two contacts K17/B			4
	contact K17/A and contact K17/B			6
	contact K 33 changer			5
	contact K 33i (inductive contact)			7
Connection PVC adhesive bushing				
	PVC adhesive bushing 63 (DN50)			A A
Connection female thread DIN ISO 228				
	PVDF			C
	stainless steel			D
	G 1			F
	G 1 1/4			G
	G 1 1/2			H
	G 2			J
Connection female thread NPT				
	PVDF			F
	stainless steel			G
	NPT 1"			F
	NPT 1 1/4"			G
	NPT 1 1/2"			H
	NPT 2"			J
Hose nozzle connection				
	PVDF			H
	stainless steel			J
	LW 25 (1")			E
	LW 32 (1 1/4")			F
	LW 38 (1 1/2")			G
	LW 50 (2")			H
Connection flange EN 1092-1				
	PVDF build in length 425 mm			K
	PVDF build in length 500 mm			L
	stainless steel build in length 425 mm			M
	stainless steel build in length 500 mm			N
	DN 40 PN 40			F
	DN 50 PN 40			G
	DN 65 PN 16			H
	DN 80 PN 16			J
Connection flange ANSI B16.5				
	PVDF build in length 425 mm			P
	PVDF build in length 500 mm			Q
	stainless steel build in length 425 mm			R
	stainless steel build in length 500 mm			S
	1 1/2" ANSI 150 RF			F
	2" ANSI 150 RF			G
	2 1/2" ANSI 150 RF			H
	3" ANSI 150 RF			J
Further design				
Please add "-Z" to order No. And specify order code				
Y01	Measured medium, always required, enter in plain text: Medium, measuring range, unit, density, density unit, viscosity, viscosity unit, oper. temp., operating pressure			
Y02	With engraved scale (>90°C /194°F)			
Y04	Silicone-free design			
Y03	Special scale markings (measuring precision 1%)			
B06	With calibration certificate			
B11	Labeling of the type plate in English			
C15	ATEX certification			
Y17	TAG plate			
C05	Factory certification 2.1 as per EN10204			
C07	Pressure test as per EN10204			
C09	Leak test as per EN10204			
C12	Material certificate for the stainless steel connection parts			
Y07	Cleaning			
S05	Shatter protection to max. 80 °C			
S06	Stainless steel stop			
D01	Built in length 450mm			

Form for Device Return

Due to the statutory provisions as well as for protection of our employees and operating equipment, we require this "CONTAMINATION DECLARATION" signed by you before your order can be processed.

Before sending the device, all residual media adhering to the device must be removed. This is particularly important if the medium presents a danger to health or the environment.

It is essential that this form be filled out completely and enclosed with the shipping papers. This also applies to additional safety data sheets and/or special handling instructions for the media to be measured.

Company information:

Company:
.....
.....

Address:
.....

Name:

Tel. No.:

Information on FVA Tubux M30:

Type:

Com. No.:

Warning notices for the medium:



toxic



hazardous
to health



corrosive



radioactive



safe



explosive



fire-
promoting



bio-
hazard

(Please cross out all that do not apply)

We hereby confirm that, in accordance with the hazard safety regulations, the returned product(s) has/have been cleaned in accordance with the medium used and is/are free of all conceivable hazardous and toxic substances and that no danger exists for people or the environment from residual media.

Date:

Signature: