



**Electromagnetic flow sensors
MID**

T a b l e o f c o n t e n t s

Electromagnetic flow Sensors



mag-flux A _____ **page 1 - 7**



mag-flux F5 _____ **page 9 - 12**



mag-flux S _____ **page 13 - 14**

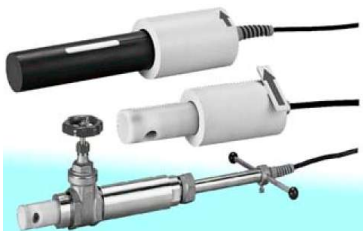

mag-flux Flowprobes _ **page 15 - 22**

AGB _____ **page 23**



Fig. 1 Electromagnetic flow Sensor *mag-flux A*

Application

Electromagnetic flow sensors *mag-flux A* are precision measuring devices, suitable for determining the flow rate of nearly any electrically conductive fluid, but also for substances such as sludge, pulp and paste.

Due to the magnetic field, the device can be used to measure flow rates up to 10 m/s (32.8 ft/s) and a minimum conductivity of 3 µS/cm, when using a synchronized static field.

The entire measuring device comprises a flow sensor and a dedicated transmitter. Those can be delivered either separately or as a compact unit.

The electromagnetic flow sensors *mag-flux A* are applied mainly in the following industries:

- Water and sewage plants
- Chemical and pharmaceutical industry
- Food and beverage industry
- Mining, cement and mineral materials
- Pulp and paper industry
- Steel industry
- Energy industry, public utilities

Mode of operation

The units work on the principle of Faraday's law of induction, whereby, simply stated, the sensor converts the flow into voltage, proportional to the flow rate.

Special features

- solid welded steel design, therefore rugged and fail-safe
- signal amplifier inside sensor
- inside diameter of measuring tube from 15 mm (0.591")
- pressure up to 250 bar
- Liner:
 - hard rubber
 - soft rubber
 - PTFE
 - special lining upon request

- various connection types and materials
 - flange: DIN, ANSI, JIS
 - clamp
 - DIN 11851
 - and other upon request

Operating note

- The electromagnetic flow sensor is only intended for measuring the flow of electrically conductive, liquid media.
- The operator of these measuring instruments is responsible for suitability, proper use and corrosion resistance of the used materials with regard to the measuring material. It must be ensured that the materials selected for the meter parts in contact with the medium are suitable for the used process media.
- Before replacing the measuring tubes, check that the unit is free of hazardous media and is not pressurized.
- The device may only be used for the pressure and voltage limits specified on the rating plate.
- The flow meter complies with the requirements of the Pressure Equipment Directive 97/23/EC. The most hazardous permissible media are the fluids defined in group 1. See page 5
- When using flanges made from C22.8 and ST52-3, the lowest permissible temperature is -10°C (14°F).
- The sensor must not be affected by external loads.
- The units are designed for predominantly recumbent load.
- Improper installation or incorrect use of the sensors (units) may null and void any warranty.
- At the media temperatures indicated below and at DN >300, the permissible max. pressure for PN10 and PN16 is reduced accordingly:

	PN 10	PN 16
< 100 °C	10,0 bar	16,0 bar
100 °C	9,3 bar	14,9 bar
130 °C	9,0 bar	14,3 bar
150 °C	8,7 bar	13,9 bar
180 °C	8,0 bar	13,0 bar

- When returning *mag-flux* sensors to Mecon, please refer to the "Product Return Form" on page 8 of this guideline. Unfortunately, we cannot repair or inspect your device without having received the completed form.
- Installation supplies (gaskets/seals, screws, etc.) are not included with the delivery.

Installation

Basically, the measuring principle does not depend on the flow profile.

Ideally, the sensor should be installed in a pipeline with a sufficient straight run, both before and after the measuring point. Experience has shown that an inflow path of $5 \times D$ and an outflow zone of at least 2 to $3 \times D$ is required.

Provided that constant turbulence does not enter the area in which the measurement takes place (e.g. after elbows, during tangential feeds or if the valve in front of the sensor is partially open). However, should this be the case, appropriate actions must be taken to normalize the flow profile. The appropriate steps are:

- increasing the inflow and outflow zones
- using flow conditioners
- reducing the inner diameter of the pipe

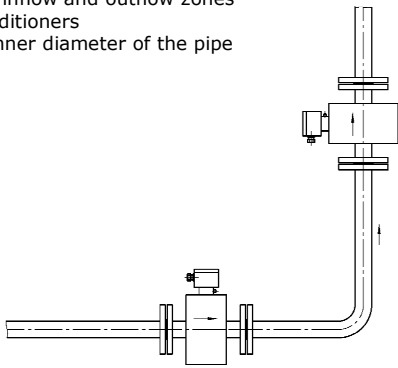

Fig. 2 Installation in horizontal and vertical pipeline

The sensors may be installed either horizontally or vertically (Fig. 2); however, it must be ensured, that the axes of the electrodes are running horizontally (see directional arrow on the electrode). This will avoid erroneous measurements due to deposits or air bubbles on the electrodes.

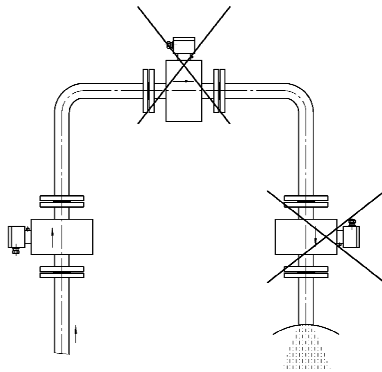

Fig. 3 Installation in risers and down pipes

Do not install the sensor in a drainage area of the pipeline (e.g. down pipe). If the sensor must be installed in a down pipe, ensure that portion of the pipeline is always filled 100% with the media.

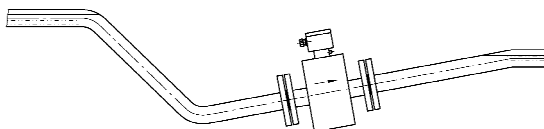

Fig. 4 Installation in a pipeline which is always filled with media

The sensor must be installed in an area of the pipe which will always be filled with media. If a pipeline is not always filled, or in case of an open channel (drainage), the sensor must be installed in a siphon (Fig. 4).

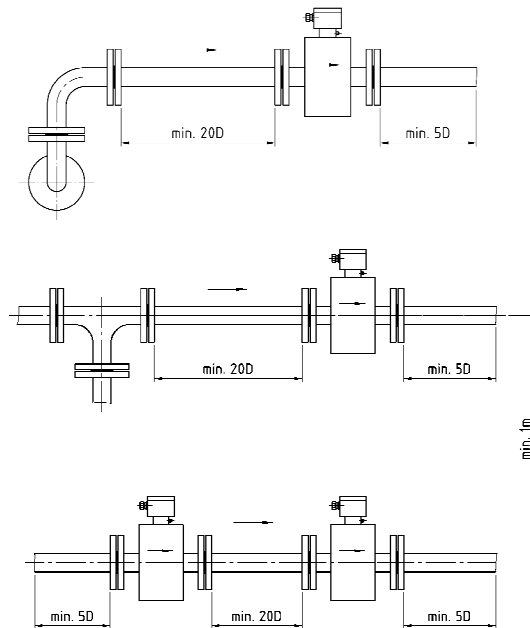
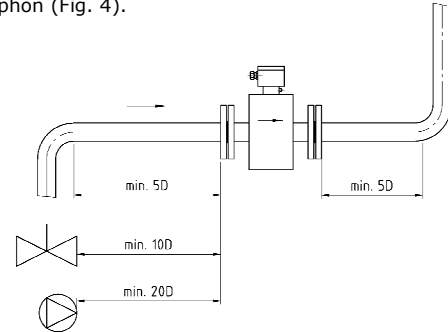

Fig. 5 Installation between tees, valves and pumps

Always maintain the distance of the pipe's straight run (Fig. 5). If these distances cannot be maintained, flow conditioners must be installed or pipes with smaller diameter must be used.

If several sensors are installed in series, the distance between each sensor must be equal to the length of one sensor. If two or more sensors are to be installed in parallel, the distance between sensors must be at least 1 m.

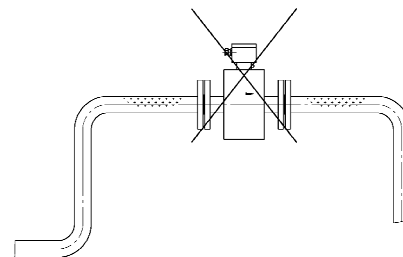

Fig. 6 Installation at highest point

Due to possible accumulation of gases, the sensor should not be installed at the highest point of a pipeline.

Technical Data

Application field	see page 1
Measuring principle	Pulsed constant field (DC)
Inlet	
Nominal diameters	DN 15 - DN 600
Process connections	<ul style="list-style-type: none"> • DIN 2501 • ANSI B 16.5 • JIS • table • special connections
Measuring accuracy	
Error of measurement	± 0,5 % of the reading from 0,25 m/s to 10 m/s
Repeat accuracy	± 0,15 % of the reading from 0,25 m/s to 10 m/s
Operational conditions	
Direction of installation	see Installation Instructions on page 2
Max. operating temperature with rubber lining	90°C/194°F; 100°C /212°F optional
with PTFE (Teflon) lining	180 °C (at 16 bar) 150 °C (at 25 bar) 100 °C (at 40 bar)
Pressure limits rubber lining	max. 250 bar
PTFE (Teflon) lining	depending on ambient temperature (see above)
Protection class	IP 67/IP 68
Requirements on the media	
Minimum conductivity	> 3 µS/cm
Max. flow rate	10 m/s
Flow rate final value	0,25 - 10 m/s
Specifications	
Design	welded steel housing
Weight	see page 5
Sensor material:	
• Measuring tube	Stainless steel mat. No. 1.4301 (or better)
• Solenoid chamber	Steel, stainless steel optional
• Flange	<ul style="list-style-type: none"> • Steel • Stainless steel • Special materials
• Lining of measuring pipe	<ul style="list-style-type: none"> • Hard rubber/soft rubber • PTFE (Teflon)
Electrodes	
• Material	<ul style="list-style-type: none"> • Mat. No. 1.4571 (Standard) • Hastelloy C4 • Titanium • Tantalum • Platinum • Monel
• Design	Mat. No. 1.4571 flat electrodes other point-plane electrodes
• Electrode sealing (rubber lining)	<ul style="list-style-type: none"> • Viton (Standard) • EPDM • Kalrez
Wiring	2 x M 16 x 1,5 / 2 x ½" NPT

Information for sensors with PTFE lining

The *mag-flux A* sensor with PTFE lining is protected using a protective disc. In order to avoid formation of a vacuum, the sensor should be installed at the lowest point of the pipeline. Do not remove or damage the bead of the lining along the flanges.

Information for sensors with soft rubber lining

Sensors with soft rubber/neoprene lining are only available from nominal diameter DN 25 mm (1").

Selection of nominal diameters

The flow depends on the flow rate and the nominal diameter DN of the flow measuring device (see system information *mag-flux* for magnetic inductive flow measurements).

Accessories

Earthing washers

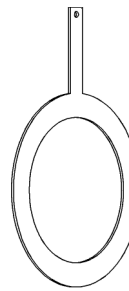

Earthing the measurement media. Necessary, if the pipes are either not electroconductive or not lined to conduct electricity (plastic pipes, concrete conduits etc.). All earthing washers must be fastened to the designated earthing screw of the sensor. See also page 4, Potential equalisation. The wall thickness of the earthing washers is 2 mm. For order code, see page 7

Protection washers for liners

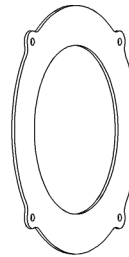

The protection washers protect the lining during transportation. The protection washer is screwed onto the sensor. Protection washers are used with all sensors lined with PTFE in order to protect the lining. They may also be used as earthing washers. When used, the installation length of the NW DN 15-150 mm will be increased by 6 mm. When used with the NW 200-600 mm, the installation length increases by 10 mm. For order code, see page 7

Protection rings for liners

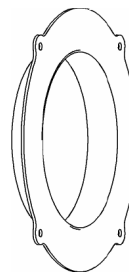

Protection rings prevent damages to the inlet and outlet edges of the sensor, in particular, if abrasive materials are being used (e.g. gravel, sand etc); at the same time, they serve as earthing washer. They are used mainly with sensors having PTFE or soft rubber lining. The protection rings are screwed to the sensor. When used, the installation length of the NW DN 15-150 mm will be increased by 6 mm. When used with the NW 200-600 mm, the installation length increases by 10 mm. For order code, see page 7

Sensor cable

Typically, the induced signal voltage of the measuring media can be several µV or mV. The transmitter can only process these minute signals noise-free if interfering signals are avoided; these include: signals interfering with the power frequency, signals which are caused by vibrations in the pipeline or in the cable run, or signals caused by strong magnetic fields in the vicinity. In this case, sufficient shielding must be provided and, if a separate design is chosen, the signal cables must be affixed firmly. For order code, see page 7

Classification per Pressure Equipment Directive

The devices are designed, based on the directive for fluids of the hazard group Gas 1. The classification varies and depends on the design. Please see table below.
For flange material C22.8 (1.0460) and ST52-5 (1.0570) a minimum temperature of -10°C (14°F) applies. For flange material 1.4571/316Ti the lowest temperature range is -20°C (-4°F).

Nom. diameter DN (inch)	Nom. pressure PN (psi)	Permissible media	Category
15 to 25 (½ to 1)	10 to 40 (145 to 580)	Gases fluid group 1 and liquids fluid group 1	Article 3.3
32 to 100 (1¼ to 4)	10 (145)	Gases fluid group 1 and liquids fluid group 1	I
32 to 50 (1¼ to 2)	16 (232)	Gases fluid group 1 and liquids fluid group 1	I
32 to 40 (1¼ to 1½)	25 (363)	Gases fluid group 1 and liquids fluid group 1	I
100 to 350 (4 to 12)	10 (145)	Gases fluid group 1 and liquids fluid group 1	II
65 to 200 (2½ to 8)	16 (232)	Gases fluid group 1 and liquids fluid group 1	II
50 to 125 (2 to 5)	25 (363)	Gases fluid group 1 and liquids fluid group 1	II
32 to 80 (1¼ to 3)	40 (580)	Gases fluid group 1 and liquids fluid group 1	II
350 to 600 (14 to 24)	10 (145)	Gases fluid group 1 and liquids fluid group 1	III
250 to 600 (10 to 24)	16 (232)	Gases fluid group 1 and liquids fluid group 1	III
150 to 600 (6 to 24)	25 (363)	Gases fluid group 1 and liquids fluid group 1	III
100 to 600 (4 to 24)	40 (580)	Gases fluid group 1 and liquids fluid group 1	III

Tightening moments of PTFE lined components PN 25 + PN 40

DN	PN 25 (Nm)	PN 40 (Nm)
25	25	25
32	35	35
40	45	45
50	55	55
65	50	50
80	50	50
100	70	70
125	100	100
150	135	135
200	140	170
250	210	260
300	220	280
350	330	410
400	440	600
500	470	560
600	650	890
700	700	920
800	1000	1370
900	1000	1430
1000	1400	1680

Potential equalization

Typically, the induced signal voltage of the measuring media can be several μV or mV . The transmitter can only process these minute signals noise-free if the voltage applies to a solid potential (earth). A good earth connection must be provided between the sensor and the pipeline. Thus, the pipeline is earthed, and the media and therefore the signal voltage have a solid signal common.

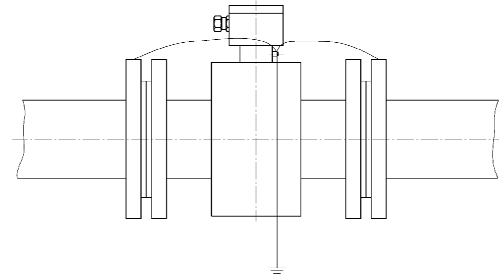

Fig. 7

When using pipes lined with electrical insulation, plastic tubing or concrete conduits, a separate earthing washer is used to earth the measuring media. The earthing washer is installed between the pipeline connection and the sensor's flange and the ring's inside contacts the media. Contrary to the diagram shown below, one earthing washer on the inflow side is sufficient. However, if bidirectional measurements are to be taken, one earthing washer must be installed on either side.

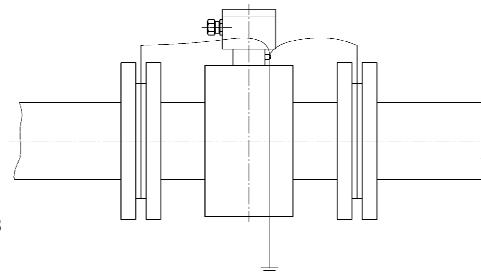

Fig. 8

Protection washers or protection rings (supplied upon request) can also be used as earthing component; or special earthing electrodes, incorporated in the sensor, may be installed. When using abrasive measuring media or pipes with large nominal diameters, earthing electrodes may prove to be more economical than earthing washers. However, it must be ensured that noticeable differences in potential within the equipment are eliminated, otherwise the earthing electrodes will electrolyze and be destroyed.

If the pipelines cannot be earthed, due to operational reasons, the sensor must be installed voltage free. To do this, a separate cable must be used to electrically connect these segments of the pipeline (min. 6mm^2 ; not included). An electrical connection occurring between the sensor and any material used for the installation must be avoided. Insulating segments must be installed between the sensor and the pipeline (e.g. PVC pipes or similar). Subsequently, earthing washers are used to electrically connect the media with the transmitter. The transmitter must not be connected with the protective earth conductor. This may only be done, if the auxiliary power is 24V DC.

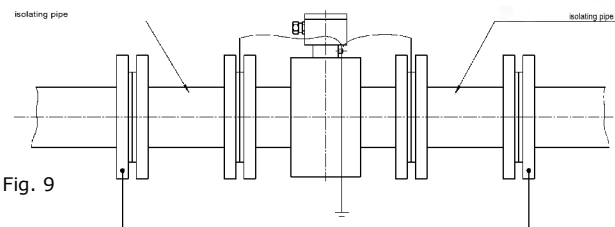

Fig. 9

Dimensions

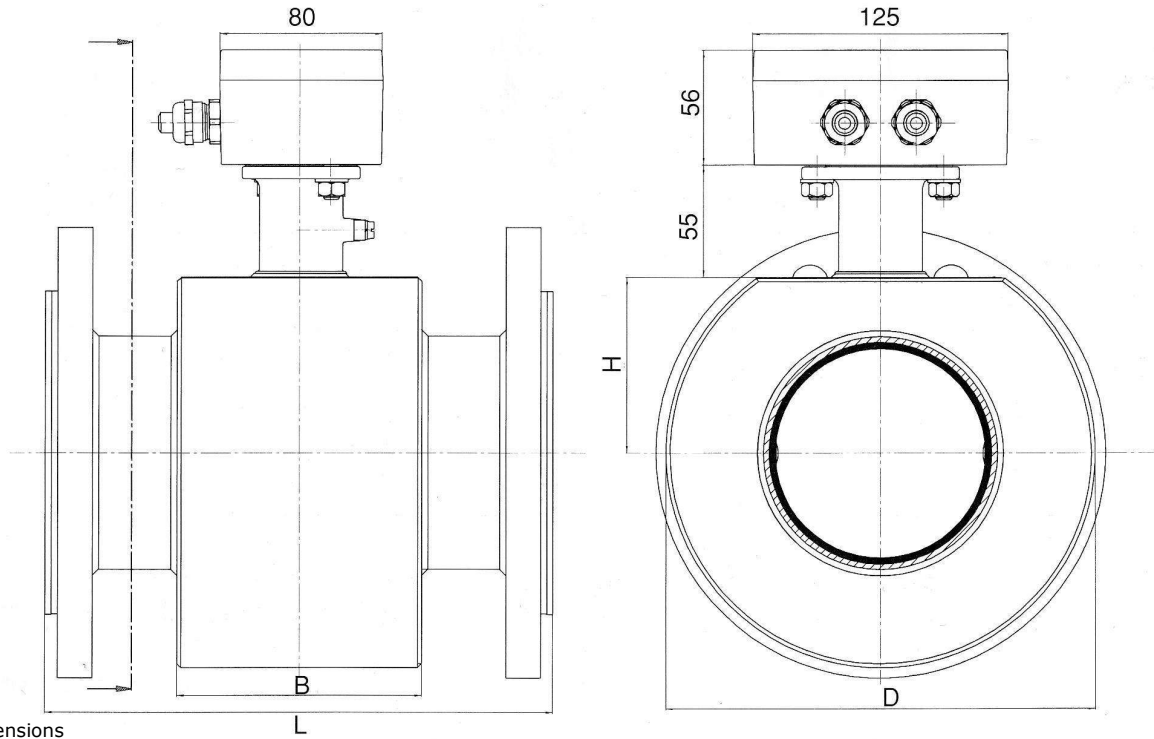

Fig. 10 Dimensions

DN	Nominal diameter		Hard- and soft rubber	Build-in-length L			Tolerance	Dimension of sensor housing			Weight in kg (DIN flange)
	DIN	ANSI		without protection washers	with protection washers	PTFE		B	D	H	
DN 15	PN 40	1/2"	150 RF	200	200	206	+0 / -3	80	130	53	5
DN 20	PN 40	3/4"	150 RF	200	200	206	+0 / -3	80	130	53	5,5
DN 25	PN 40	1"	150 RF	200	200	206	+0 / -3	80	130	53	6
DN 32	PN 40	1 1/4"	150 RF	200	200	206	+0 / -3	80	130	53	7
DN 40	PN 40	1 1/2"	150 RF	200	200	206	+0 / -3	80	130	53	7,5
DN 50	PN 40	2"	150 RF	200	200	206	+0 / -3	80	140	57	9
DN 65	PN 16	2 1/2"	150 RF	200	200	206	+0 / -3	80	155	63	10
DN 80	PN 16	3"	150 RF	200	200	206	+0 / -3	80	170	70	13
DN 100	PN 16	4"	150 RF	250	250	256	+0 / -3	120	210	86	15
DN 125	PN 16	5"	150 RF	250	250	256	+0 / -3	120	240	98	19
DN 150	PN 16	6"	150 RF	300	300	306	+0 / -3	120	285	117	23
DN 200	PN 10	8"	150 RF	350	350	360	+0 / -3	200	350	143	36
DN 250	PN 10	10"	150 RF	450	450	460	+0 / -4	200	440	180	52
DN 300	PN 10	12"	150 RF	500	500	510	+0 / -4	200	520	213	62
DN 350	PN 10	14"	150 RF	550	550	560	+0 / -5	225	474	237	95
DN 400	PN 10	16"	150 RF	600	600	610	+0 / -5	250	524	262	115
DN 450	PN 10	18"	150 RF	600	600	610	+0 / -5	270	584	292	135
DN 500	PN 10	20"	150 RF	600	600	610	+0 / -5	300	629	315	150
DN 600	PN 10	24"	150 RF	600	600	610	+0 / -5	360	734	367	182

Ordering data (rubber lining)

Electromagnetic flow sensor mag-flux A

	M	A	G	5	7	-	-	-	-	-	-	0
Nominal pressure												
• PN 10												1
• PN 16 / 150 lb												2
• PN 25 / 300 lb												3
• PN 40												4
Design												
• compact												1
• remote												2
Liner												
• Hard rubber												
- Standard VHE / 102												1
- up to 100°C VHE / 102												2
- potable water VHE / 102												3
• Soft rubber												
- Standard VWE/R61												4
- Neopren BWE/502												5
- potable water VWE/645												6
Nominal diameter												
• DN 15 / 1/2"												A
• DN 20 / 3/4"												B
• DN 25 / 1"												C
• DN 32 / 1 1/4"												D
• DN 40 / 1 1/2"												E
• DN 50 / 2"												F
• DN 65 / 2 1/2"												G
• DN 80 / 3"												H
• DN 100 / 4"												J
• DN 125 / 5"												K
• DN 150 / 6"												L
• DN 200 / 8"												M
• DN 250 / 10"												N
• DN 300 / 12"												P
• DN 350 / 14"												Q
• DN 400 / 16"												R
• DN 450 / 18"												Y
• DN 500 / 20"												S
• DN 600 / 24"												T
• other nominal diameters												Z
Connection and connection material												
• DIN 2501, mat.No. 1.0460/ 1.0570												A
• DIN 2501, mat.No. 1.4571												B
• ANSI B16.5 150 RF, mat.No. 1.0432/ 1.0570												C
• ANSI B16.5 300 RF, mat.No. 1.0432/ 1.0570												D
• other connections / other materials												Z
Electrode material												
• Edelstahl (mat.No. 1.4571)												1
• Hastelloy C4 (mat.No. 2.4610)												2
• Titanium												3
• Tantalum												4
• Monel												5
• Platinum												6
• other electrode materials												9
Protection washers / Protection rings												
• without												0
• with protection washers (order as accessory)												1
• with protection rings (order as accessory)												2
Cable gland entires												
• M 16 x 1,5												C
• NPT 1/2"												B
Degree of protection												
• IP 67 / NEMA 5												B
• IP 68 / NEMA 6 with 5m firmly connected cable												C
• IP 68 / NEMA 6 with 10m firmly connected cable												D
Further designs												
• one earthing electrode made of mat.No. 1.4571												A 0 1
• one earthing electrode made of mat.No. 2.4610												A 0 3
• with 3-point calibration certificate												B 0 6
• with 6-point calibration certificate												B 0 7
• TAG plate inscription in english												B 1 1
• acceptance test EN 10204:2004 3.1												C 1 2
• Silicone-free materials												Y 0 4
• TAG plate stainless steel												Y 1 7

Ordering data (PTFE lining)

Electromagnetic flow sensor mag-flux A

	M	A	G	5	7	0	-	-	-	-	-	0
Nominal pressure												
• PN 10												1
• PN 16 / 150 lb												2
• PN 25 / 300 lb												3
• PN 40												4
Design												
• remote												1
• compact												2
Nominal diameter												
• DN 15 / 1/2"												A
• DN 20 / 3/4"												B
• DN 25 / 1"												C
• DN 32 / 1 1/4"												D
• DN 40 / 1 1/2"												E
• DN 50 / 2"												F
• DN 65 / 2 1/2"												G
• DN 80 / 3"												H
• DN 100 / 4"												J
• DN 125 / 5"												K
• DN 150 / 6"												L
• DN 200 / 8"												M
• DN 250 / 10"												N
• DN 300 / 12"												P
• DN 350 / 14"												Q
• DN 400 / 16"												R
• DN 450 / 18"												Y
• DN 500 / 20"												S
• DN 600 / 24"												T
• other nominal diameters												Z
Connection and connection material												
• DIN 2501, mat.No. 1.0460/ 1.0570												A
• DIN 2501, mat.No. 1.4571												B
• ANSI B16.5 150 RF, mat.No. 1.0432/ 1.0570												C
• ANSI B16.5 300 RF, mat.No. 1.0432/ 1.0570												D
• other connections / other materials												Z
Electrode material												
• Edelstahl (mat.No. 1.4571)												1
• Hastelloy C4 (mat.No. 2.4610)												2
• Titanium												3
• Tantalum												4
• Monel												5
• Platinum												6
• other electrode materials												9
Protection washers / Protection rings												
• without												0
• with protection washers (order as accessory)												1
• with protection rings (order as accessory)												2
Cable gland entires												
• M 16 x 1,5												C
• NPT 1/2"												B
Degree of protection												
• IP 67 / NEMA 5												B
• IP 68 / NEMA 6 with 5m firmly connected cable												C
• IP 68 / NEMA 6 with 10m firmly connected cable												D
Further designs												
• one earthing electrode made of mat.No. 1.4571												A 0 1
• one earthing electrode made of mat.No. 2.4610												A 0 3
• with 3-point calibration certificate												B 0 6
• with 6-point calibration certificate												B 0 7
• TAG plate inscription in english												B 1 1
• acceptance test EN 10204:2004 3.1												C 1 2
• Silicone-free materials												Y 0 4
• TAG plate stainless steel												Y 1 7

Ordering data (earthing washer)

MAG5901 - 0 - 0 AAA0

Liner		
• Hard rubber / Soft rubber	1	A
• PTFE	0	B
Nominal diameter		
• DN 15 / 1/2"		A
• DN 20 / 3/4"		B
• DN 25 / 1"		C
• DN 32 / 1 1/4"		D
• DN 40 / 1 1/2"		E
• DN 50 / 2"		F
• DN 65 / 2 1/2"		G
• DN 80 / 3"		H
• DN 100 / 4"		J
• DN 125 / 5"		K
• DN 150 / 6"		L
• DN 200 / 8"		M
• DN 250 / 10"		N
• DN 300 / 12"		P
• DN 350 / 14"		Q
• DN 400 / 16"		R
• DN 450 / 18"		Y
• DN 500 / 20"		S
• DN 600 / 24"		T
• other nominal diameters		Z
Connection		
• DIN 2501	1	
• ANSI B16.5 RF	2	
• other connections	9	

Ordering data (protection ring)

MAG5911 - 0 - 0 AAA0

Liner		
• Hard rubber / Soft rubber	1	A
• PTFE	0	B
Nominal diameter		
• DN 15 / 1/2"		A
• DN 20 / 3/4"		B
• DN 25 / 1"		C
• DN 32 / 1 1/4"		D
• DN 40 / 1 1/2"		E
• DN 50 / 2"		F
• DN 65 / 2 1/2"		G
• DN 80 / 3"		H
• DN 100 / 4"		J
• DN 125 / 5"		K
• DN 150 / 6"		L
• DN 200 / 8"		M
• DN 250 / 10"		N
• DN 300 / 12"		P
• DN 350 / 14"		Q
• DN 400 / 16"		R
• DN 450 / 18"		Y
• DN 500 / 20"		S
• DN 600 / 24"		T
• other nominal diameters		Z
Connections		
• DIN 2501	1	
• ANSI B16.5 RF	2	
• other connections	9	

Ordering data (protection washer)

MAG5921 - 0 - 0 AAA0

Liner		
• Hard rubber / Soft rubber	1	
• PTFE	0	
Nominal diameter		
• DN 15 / 1/2"		A
• DN 20 / 3/4"		B
• DN 25 / 1"		C
• DN 32 / 1 1/4"		D
• DN 40 / 1 1/2"		E
• DN 50 / 2"		F
• DN 65 / 2 1/2"		G
• DN 80 / 3"		H
• DN 100 / 4"		J
• DN 125 / 5"		K
• DN 150 / 6"		L
• DN 200 / 8"		M
• DN 250 / 10"		N
• DN 300 / 12"		P
• DN 350 / 14"		Q
• DN 400 / 16"		R
• DN 450 / 18"		Y
• DN 500 / 20"		S
• DN 600 / 24"		T
• other nominal diameters		Z
Material		
• Stainless steel (mat.No. 1.4571)		A
• Hastelloy C4 (2.4610)		B
• other materials		Z
Connection		
• DIN 2501	1	
• ANSI B16.5 RF	2	
• other connections	9	

Ordering data (sensor cable)

MAG5930 - 0 - A00 - 0 AAA0

Sensor cable consisting of:	
Magnet current cable (3 x 1,0 mm ²)	
Electrode cable (3 x 1,0 mm ²)	
• Length: 5 m	B
• Length: 15 m	C
• Length: specify other length in plain text	Z

M E C O N

FLOW - CONTROL - SYSTEMS

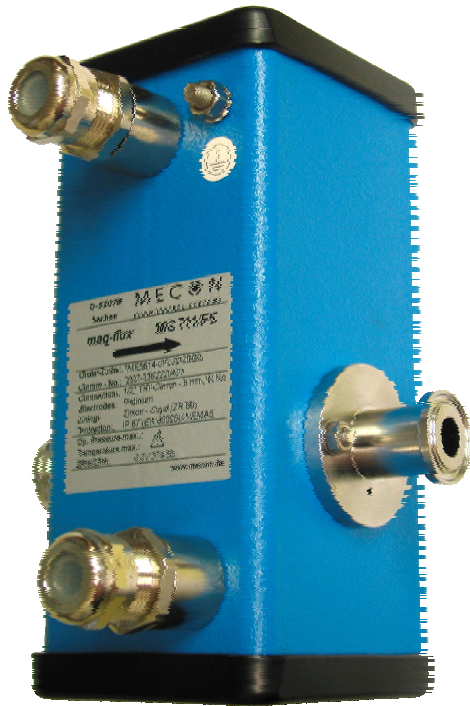

Fig. 1 electromagnetic flow sensor *mag-flux F5*

Application

Electromagnetic flowmeters are suitable for measuring the flow of almost all electrically conducting liquids, as well as sludges, pastes and slurries.

A prerequisite is that the medium must have a certain minimum conductivity. The temperature, pressure, viscosity and density have no influence on the result.

This special design of an electromagnetic flowmeter (MID) is particularly suitable for measuring the flow of extremely small quantities and especially for use with proportioning and batching systems. In conjunction with the transmitters Intermag 2/Transmag 2, complex tasks can be solved using the integral software for batching applications. Typical applications can be found in the food industry, the dosing of chemicals in photographic systems, and the dosing of medicines in medical fields.

When using the alternating field technique with the transmitter Transmag 2, even very small flows can be exactly measured as a result of the larger magnetic field and the zero stability.

The flow sensors *mag-flux F5* are used mainly in the following industries:

- Water and waste water plants
- Chemical and pharmaceutical industry
- Food- and beverage industry
- Mining, cement and mineral materials
- Pulp- and paper industry
- Steel industry
- Power generation and distribution.

The flow sensor are combined with the transmitters Intermag 2/Transmag 2 and are only available as remote versions.

Special features

- Metering tube made from high corrosion- and temperature resistant zirconium oxide
- Metering tube inner diameter 2 mm (0,078") and above
- smallest measuring ranges:
 - 0 to 5 l/h (0 to 0,022 USgpm) with constant field
 - 0 to 3 l/h (0 to 0,0132 USgpm) with alternating field
- very low minimum conductivity:
 - 10 μ S/cm with constant field
 - 0,1 μ S/cm with alternating field
- robust and interference-free as a result of closed steel housing
- different process connections and materials
 - Thread: DIN, NPT, BSP
 - Flange: DIN, ANSI, JIS
 - Clamp
 - DIN 11851
 - and more upon request
- different process connection materials
 - Mat. No. 1.4571
 - Hastelloy C4 W. Nr. 2.4610
 - PVDF with earthing ring made from Hastelloy C4 mat. No. 2.4610
 - Titanium
 - and more upon request

Note of application

- The operator of these measuring instruments is responsible for suitability, proper use and corrosion resistance of the used materials with regard to the measuring material. It must be ensured that the materials selected for the meter parts in contact with the medium are suitable for the used process media.
- Before replacing the measuring tubes, check that the meter is free of hazardous media and is not pressurized.
- The unit may only be used within the pressure and voltage limits specified on the rating plate.
- The flowmeter complies with the requirements of the Pressure Equipment Directive 97/23/EC, article 3, paragraph 3. The most hazardous permissible media are the fluids defined in group 1.
- Provide a touch guard for surface temperatures of $> 70^{\circ}\text{C}$. This touch guard must be designed in a way that the max. allowable ambient temperature on the unit is not exceeded.
- The sensor must not be affected by external loads.
- The units are designed for predominantly recumbent load.

Installation

The measuring principle is generally independent of the flow profile. Ideally, the device should be installed in a pipeline, which has sufficient straight tubing before and after the measuring point. In general, an inlet path of min. 5 x dia. and an outflow zone of min. 2-3 x dia. is required.

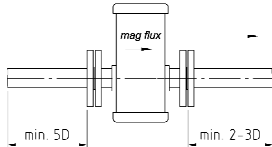

Provided that constant turbulence does not enter the area in which the measurement takes place (e.g. after elbows, during tangential feeds or if the valve in front of the sensor is partially open). In such cases measures to normalize the flow profile are necessary. Suitable measures in this respect are:

- increasing the inlet and outlet zones
- using flow conditioners
- reducing the inner diameter of the pipe

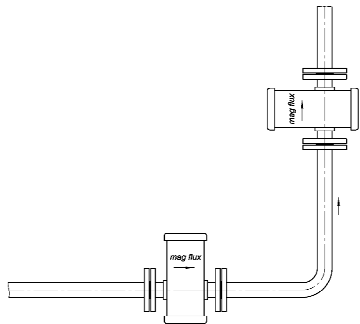

Fig. 2 Installation in horizontal and vertical pipelines

Installation may be horizontal or vertical (Fig. 2) but it must be ensured that the axes of the electrodes run horizontally (the direction arrow marks the electrode axes) to avoid measuring errors due to deposits or air bubbles on the electrodes.

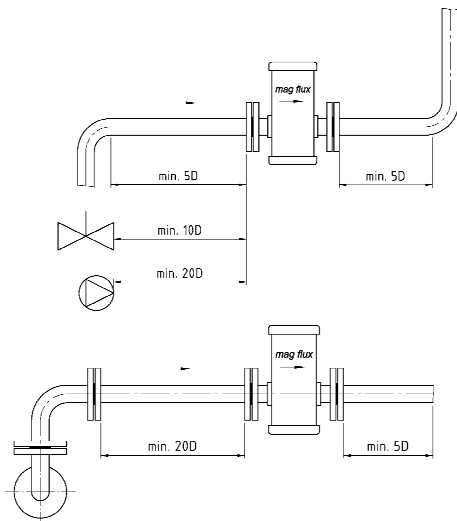

Fig. 3 Installation between pipe elbows, valves and pumps

The inlet and outlet zones must be kept straight (Fig. 3).

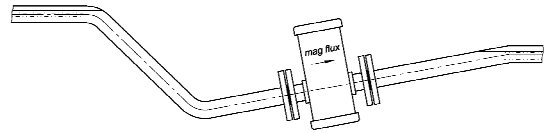

Fig. 4 Installation in a constantly filled pipe

The flow measuring device must be installed so that the measuring pipe cannot run empty and is always filled with medium. The sensor must be installed in a culvert in the case of an unfilled pipe or only a free level line (outlet).

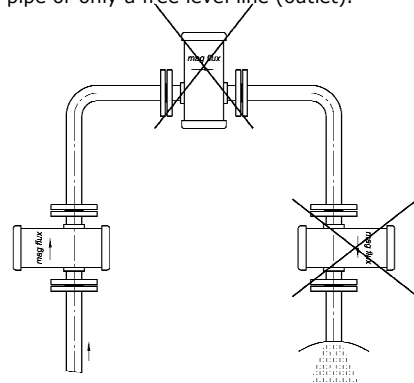

Fig. 5 Installation in pipes without emptying

The sensor should not be installed in pipe sections with a free pipe outlet which could run empty (e.g. downpipes). When installing in a downpipe make sure that the pipe is always filled 100% with the medium.

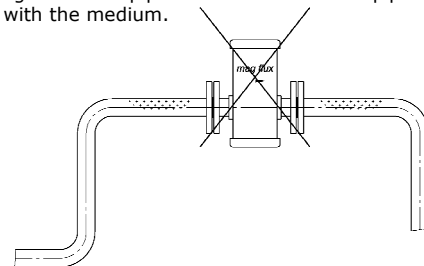

Fig. 6 Installation at the highest point

Avoid installation at the highest point of the pipe due to accumulation of gas.

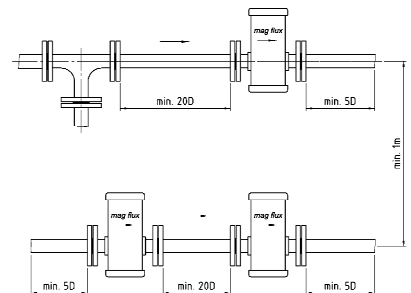

Fig. 7 Installation of several sensors, either in series or in parallel

If several sensors are series connected, the distance between the individual sensors must be at least equal to the length of one sensor. If two or more sensors are to be connected in parallel, the distance must be at least 1 m.

Dimensions

mag-flux F5

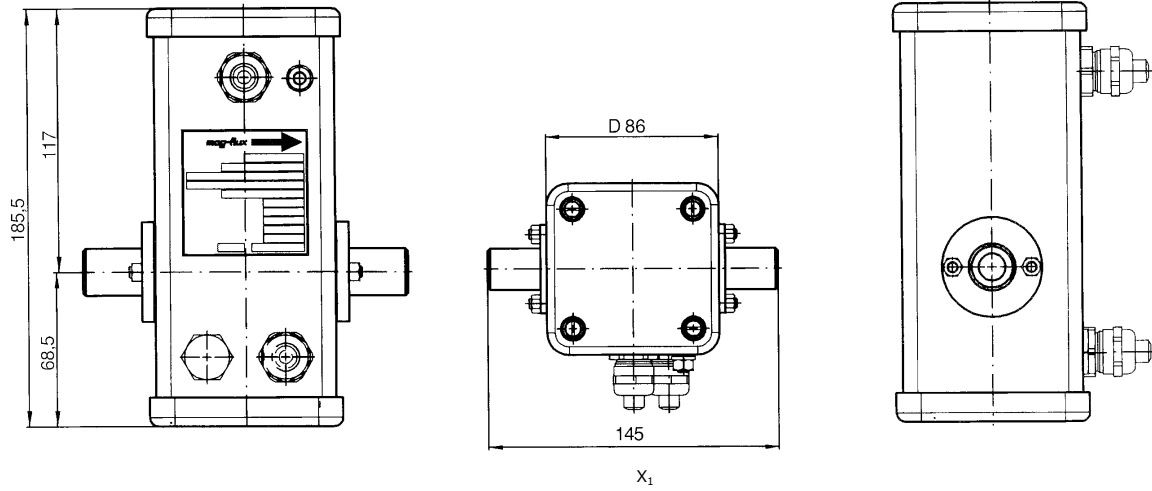

Fig. 2 Electromagnetic flow Sensor *mag-flux F5* (without wall mount), dimensions in mm

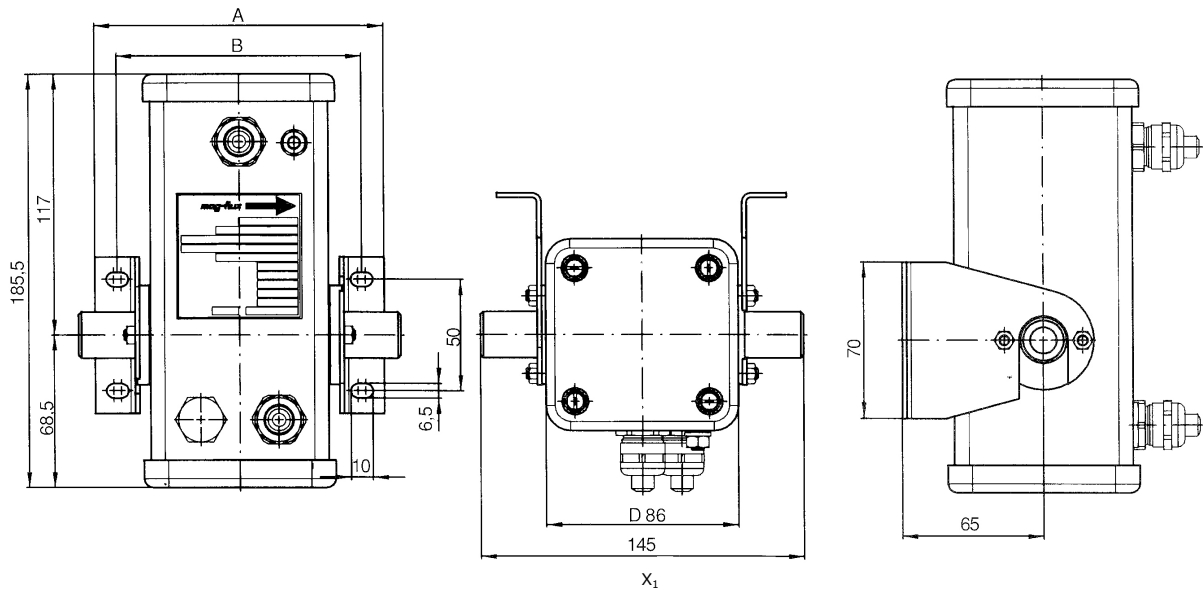

Fig. 3 Electromagnetic flow Sensor *mag-flux F5* (with wall mount), dimensions in mm

Connection material	Dimension A	Dimension B
Metal	133	132
Plastic	140	120

X₁: if flange connection material is PVDF, installation dimension is 160mm!

Technical Data

Application field	see page 9		
Measuring principle	pulsed constant field (DC) pulsed alternating field (AC)		
Inlet			
Nominal diameter metering tube	Measuring range		
	Constant field	Alternating field	
2 mm (0,078")	5 - 110 l/h	3 - 110 l/h	
4 mm (0,156")	25 - 450 l/h	15 - 450 l/h	
8 mm (0,312")	100 - 1800 l/h	60 - 1800 l/h	
12 mm (0,47")	200 - 4000 l/h	120 - 4000 l/h	
Measuring accuracy			
Error of measurement	± 0,5 % of measured value 0,25 m/s to 10 m/s		
Repeat accuracy	± 0,15 % of measured value 0,25 m/s to 10 m/s		
Operational conditions			
Mounting position	vertical or horizontal		
Max. operating temperature	150°C / 302°F		
Pressure limits	25 bar/ 362,5 psi higher upon request		
<u>Pressure/temperature limits with PVDF connections (DIN 8062)</u>	Temperature	Max. pressure	
	°C	°F	Bar Psi
	0 - 50	32 - 122	10 145
	60	140	8,5 123
	70	158	7,5 109
	80	176	6,5 94
	90	194	5,5 80
	100	212	4,5 65
	110	230	3,8 55
	120	248	3,0 44
Protection class	IP 67/IP 68		
Minimum conductivity			
• with constant field	> 10 µS/cm		
• with alternating field	> 0,1 µS/cm		
Specifications			
Design	Fully-welded steel fitting with cover made of aluminium		
Weight	approx. 3 kg		
Cable inlet			
• with constant field	2 x M 16 x 1,5 / 2 x ½" NPT		
• with alternating field	3 x M 16 x 1,5 / 3 x ½" NPT		
Material			
• Metering tube	Zirconium oxide		
• Sensor housing	Steel		
• Process connection	Stainless Steel, Hastelloy, PVDF		
Electrodes			
• Material	Platinum 99,9%, sintered		
• Design	Flat electrode		

Ordering data

Electromagnetic flow Sensor mag-flux F5

MAG 5 6 1	-	0	0	-	0	0
Measuring principle	3					
• alternating field	4					
• constant field						
Nominal diameter of metering tube						
• 2 mm				D		
• 4 mm				E		
• 8 mm				F		
• 12 mm				G		
Process connection						
• G 1/2, mat.No. 1.4571				A		
• G 1/2, HC4 (mat.No. 2.4610)				B		
• G 1/2, PVDF with HC4- earthing rings (mat.No. 2.4610)				C		
• G 1/2, Titanium				S		
• NPT 1/2", mat.No. 1.4571				D		
• NPT 1/2", HC4 (mat.No. 2.4610)				E		
• NPT 1/2", PVDF with HC4- earthing rings (mat.No. 2.4610)				F		
• DN 15 PN 25 DIN 2501, mat.No. 1.4571				H		
• DN 15 PN 25 DIN 2501, HC4 (mat.No. 2.4610)				J		
• DN 15 PN 25 DIN 2501,				K		
PVDF with HC4- earthing rings (mat.No. 2.4610)						
• 1/2" Tri-Clamp, mat.No. 1.4571				L		
• 1" Tri-Clamp, mat.No. 1.4571				N		
• 1/2" ANSI B16.5 150 RF, mat.No. 1.4571				Q		
• 1/2" ANSI B16.5 150 RF,				T		
PVDF with HC4- earthing rings (mat.No. 2.4610)						
• other connections/ materials				Z		
Gasket material						
• EPDM				2		
• Kalrez				3		
Wall mount						
• without				0		
• with				1		
Screwed gland						
• M16 x 1,5				C		
• NPT 1/2"				B		
Degree of protection						
• IP 67 / NEMA 5				B		
• IP 68 / NEMA 6 mit 5m firmly connected cable				C		
• IP 68 / NEMA 6 mit 10m firmly connected cable				D		
Further designs						
• Measuring range < 10 l/h				A10		
• TAG plate inscription in english				B11		
• with 3-point calibration certificate				B06		
• with 6-point calibration certificate				B07		
• Silicone-free materials				Y04		
• TAG plate stainless steel				Y17		



Fig. 1 Electromagnetic flow Sensor *mag-flux S*

Application

These electromagnetic flow sensors (MID) are suitable for measuring standard applications.

A prerequisite is that the medium must have a certain minimum conductivity in dependence on the used sensor. The temperature, pressure, density and viscosity have no influence on the result.

The special design of this electromagnetic flowmeter (MID) is in particular of his extremely robust and compact but light-weight construction used to built-in plastic pipes without reinforcement. Integrated earthing rings guarantee best measuring results and ensure also a safe connection built-in in steel pipes.

The main applications of the flow sensor *mag-flux S* can be found in the following fields:

- Water and waste water
- Food- and beverage industry
- Steel industry
- Power generation and distribution.

The flow sensors are combined with the transmitter InterMag 2 and are only available as remote version.

Special features

- Extremely compact and light weighted design
- Suitable for installation in plastic or steel pipes
- Sensor firmly connected to stainless steel rings
- No other earthing required
- No additional pressure loss
- No movable parts

Connection and mode of operation

The flange-less sensor is firmly screwed between flange connections. The following table shows the suitable installations for the respective nominal diameters.

DIN 2501 (BS 4504)

PN	15	20	25	32	40	50	65	80	100
6	-	-	x	x	x	x	x	x	x
10	x	x	x	x	x	x	x	x	x
16	x	x	x	x	x	x	x	x	x
25	x	x	x	x	x	x	x	x	x
40	x	x	x	x	x	x	x	x	x

ANSI B16.5

	1/2"	3/4"	1"	1 1/4"	1 1/2"	2"	2 1/2"	3"	4"
150	-	-	x	x	x	x	x	x	x
300	x	x	x	x	x	x	x	x	x

Sensor cable

The measuring sensor 711/S is fitted with a factory-installed, permanently attached cable, 5 m (16.4 ft) long. This cable may be extended via a proper junction box. If an extension is used, it is imperative to employ 2 separate and shielded cables for the electrode circuit and the magnetic circuit. We recommend cable type 2 x LiYCY 2 x 1.0 mm² (2 x 0.0016 in²).

The max. cable length between sensor and transducer must not exceed 50 m (165 ft) and depends on the conductivity of the material which is being measured. Furthermore, particular attention should be given to the cable run. All signal lines must be protected against vibration and the effects of magnetic and leakage fields. If in doubt, the sensor cable should be run inside an earthed conduit.

Note of application

- The operator of these measuring sensors is responsible for suitability, proper use and corrosion resistance of the used materials with regard to the measuring material. It must be ensured that the materials selected for the meter parts in contact with the medium are suitable for the used process media.
- Before replacing the measuring tubes, check that the meter is free of hazardous media and pressure.
- The unit may only be used within the pressure and voltage limits specified in the operating instructions.
- The flowmeter complies with the requirements of the Pressure Equipment Directive 97/23/EC, article 3, paragraph 3. The most hazardous permissible media are the fluids defined in group 1.
- Provide a touch guard for surface temperatures of > 70°C. This touch guard must be designed in a way that the max. allowable ambient temperature on the unit is not exceeded.
- The sensor must not be affected by external loads
- The units are designed for predominantly recumbent load.

Technical Data

Application field	see page 13
Mode of operation	see page 13
Measuring principle	Pulsed constant field (DC)
Inlet	
Nominal diameters	DN 15 - DN 100
Measuring accuracy	
Error of measurement	± 0,5 % of measured value 0,25 m/s to 10 m/s
Repeat accuracy	± 0,15 % of measured value 0,25 m/s to 10 m/s

Operational conditions

Mounting position	vertical or horizontal
permissible ambient temperature	-15°C - 50°C / 5 - 122 °F
permissible operating temperature	-15°C - 60°C / 5 - 140°F

Pressure/temperature limits with PVC- connection (DIN 8062)

Temperature		Max. pressure	
°C	°F	Bar	Psi
10	50	18	261
20	68	16	232
30	86	13	189
40	104	10	145
50	122	6	87
60	140	4	58

Pressure/temperature limits with PVDF- connection (DIN 8062)

Temperature		max. pressure	
°C	°F	Bar	Psi
10	50	18	261
20	68	16	232
30	86	13	189
40	104	11	160
50	122	9	80
60	140	8	65

Protection class

IP 67 (NEMA 4x) / optionally IP 68 (NEMA 6)

Medium conditions

Minimum conductivity	> 20 µS/cm with 5m sensor cable length
Flow rate	0,25 - 12 m/s

Specifications

Design	Outer casing steel, nickel-plated
Connection	Flange-less connection (sandwich)
Weight	See table of dimensions
Cable inlet	Firmly installed, length 5m
Material	
• Metering tube	PVC or PVDF
• Sensor housing	Steel, nickel-plated
• Process connection	Stainless steel mat. No. 1.4305, Special materials
• Gasket metering tube	Viton
• Gasket outer casing	Buna N
Electrodes	
• Material	Stainless steel mat. No. 1.4571, Special materials
• Design	Flat electrode
• Gasket	Viton, Special materials

Dimensions

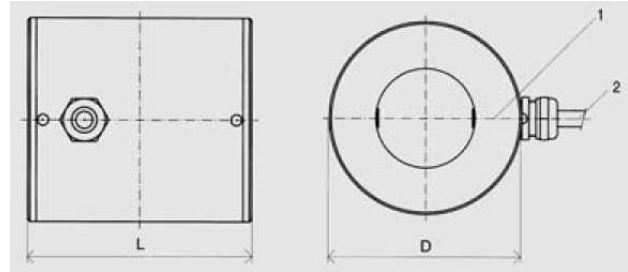

Fig. 2 Sensor mag-flux S, dimensions

1. Electrode axis
2. Sensor cable

Diameter		L		D		Weight	
mm	(inch)	mm	(inch)	mm	(inch)	kg	(lb)
15	(1/2)	74	2,91	51	2,01	1,4	3,09
20	(3/4)	74	2,91	57	2,24	1,4	3,09
25	1	74	2,91	63,5	2,5	1,4	3,09
32	(1 1/4)	105	4,13	73	2,87	3	6,61
40	(1 1/2)	105	4,13	82,5	3,25	3	6,61
50	2	105	4,13	95	3,74	3	6,61
65	(2 1/2)	150	5,91	114,3	4,5	6,2	13,56
80	3	150	5,91	127	5	6,2	13,56
100	4	150	5,91	146	5,75	6,2	13,56

Ordering data

Electromagnetic flow Sensor mag-flux S

MAG5410 - A 0 - 0 A0

Metering tube materials and nominal diameters

- Metering tube made of PVC, DN 15 **1D**
- Metering tube made of PVC, DN 20 **1E**
- Metering tube made of PVC, DN 25 / ANSI 1 **1F**
- Metering tube made of PVC, DN 32 / ANSI 1 1/4 **1G**
- Metering tube made of PVC, DN 40 / ANSI 1 1/2 **1H**
- Metering tube made of PVC, DN 50 / ANSI 2 **1J**
- Metering tube made of PVC, DN 65 / ANSI 2 1/2 **1K**
- Metering tube made of PVC, DN 80 / ANSI 3 **1L**
- Metering tube made of PVC, DN 100 / ANSI 4 **1M**

- Metering tube made of PVDF, DN 15 **2D**
- Metering tube made of PVDF, DN 20 **2E**
- Metering tube made of PVDF, DN 25 / ANSI 1 **2F**
- Metering tube made of PVDF, DN 32 / ANSI 1 1/4 **2G**
- Metering tube made of PVDF, DN 40 / ANSI 1 1/2 **2H**
- Metering tube made of PVDF, DN 50 / ANSI 2 **2J**
- Metering tube made of PVDF, DN 65 / ANSI 2 1/2 **2K**
- Metering tube made of PVDF, DN 80 / ANSI 3 **2L**
- Metering tube made of PVDF, DN 100 / ANSI 4 **2M**

Materials metering tube connection

- mat. No. 1.4305 **1**
- other materials **9**

Degree of protection

- IP 67 / NEMA 5 (cable length 5 m) **B**
- IP 68 / NEMA 6 (cable length 5 m) **C**

Further designs:

- TAG plate inscription in english **B11**
- with 3- point calibration certificate **B06**
- with 6- point calibration certificate **B07**
- Silicone-free materials **Y04**
- TAG plate stainless steel **Y17**



Fig. 1 Electromagnetic flow Sensor *mag-flux* MIS 1/D, MIS 2/15 and Flow probe

Application

The magnetic inductive flowmeters *mag-flux* MIS 1/D and *mag-flux* MIS 2/15 are suitable for velocity and flow measurements of nearly all electrically conductive fluids. In addition to the already well-known flowmeters *mag-flux* A, *mag-flux* S and *mag-flux* F5, they offer a well-priced option to your flow measuring applications.

Due to the constant magnetic field, the sensors *mag-flux* MIS 1/D and *mag-flux* MIS 2/15 can be used for medium flow rates up to 3 m/s or 10 m/s (9.84 ft/s or 32.8 ft/s) respectively and a conductivity as low as 20 $\mu\text{S}/\text{cm}$. Temperature, pressure, density and viscosity do not affect the result of the measurement.

The complete measuring device comprises at least one magnetic inductive sensor and a dedicated transmitter. The units work on the principle of Faraday's law of induction, whereby, simply stated, voltage is induced to a conductor which is moving through a magnetic field.

The magnetic inductive sensors *mag-flux* MIS 1/D and *mag-flux* MIS 2/15 are applied mainly in the following industries:

- Water and sewage plants
- Steel industry
- Energy industry, public utilities

Connection and Operation

The sensors work based on the magnetic inductive measuring principle. They are delivered as fully calibrated units and can be installed and set to measure the flow rate in a particular pipe line, using the respective transducer for constant magnetic field measurements. As in most common measuring devices, the prerequisite here is a minimum conductivity of the medium which is to be measured, in this case of approx. 20 $\mu\text{S}/\text{cm}$

Special features

- Sensors available for nearly all nominal diameters and substances (from DN 200 (8") to DN 2000 (80"))
- Easy installation of the sensors, even in existing pipelines
- Quick replacement, anytime
- Sensors can be installed or replaced even under operating conditions
- Calibrated sensors can be easily stored
- Sensor *mag-flux* MIS 1/D suitable for highly contaminated media
- No moving parts, therefore very low maintenance
- Protection class IP 68/NEMA6 with 5 m (16.4 ft) attached cable
- Use of max. 2 sensors with 1 transmitter
- Economical flow rate measurements for large pipe diameters

Installation guideline for standard sensors

The sensors *mag-flux* MIS 1/D and *mag-flux* MIS 2/15 should be installed in a straight run of a pipe line, both for the inlet path and the outflow zone. Generally speaking, a lateral installation is most appropriate when mounted in the horizontal run of a pipeline. The sensors should be mounted using a fitting aid, which can be ordered separately. This component should be welded into the pipe as follows:

- *mag-flux* MIS 2/15 the center of the measuring channel or
- for sensor *mag-flux* MIS 1/D, the centre of the electrode's surface should be 0.12 x di away from the pipe's inside diameter (di = inner pipe diameter).

Based on hydraulic principles, the median flow velocity is 0.12 x di away from the inner wall of the tube. Independent from the Reynolds' number, this applies – as a good approximation – even within the range of laminar flow.

The supplied fitting aids have markings corresponding with the various inner diameters of a tube. Each fitting aid has 2 spigots, which fit into the recesses of the sensors. The spigots must point in the direction of the flow. This defines the orientation of the sensor. When using sensor *mag-flux* MIS 1/D, the axis of the electrode must be 90° to the axis of the flow; while the measuring channel of the sensor *mag-flux* MIS 2/15 must be positioned in the direction of the flow; this can be verified when checking the labelling during installation (see sensor cover). See also system information *mag-flux*

Note of application

- The operator of these measuring instruments is solely responsible for applicability, proper use and the corrosion resistance of the used materials with respect to the media. It is imperative that the selected materials for the measuring instrument's components which come into contact with the media are suitable for the media selected for this process.
- Before replacing the measuring tubes, ensure no hazardous substances remain in the system and the unit is not pressurised.
- The unit may only be used within the pressure and voltage limits specified in the operating instructions.
- The flowmeter complies with the requirements according to Article 3 Paragraph 3 of the Pressure Equipment Directive 97/23/EC. The most hazardous permissible media are the fluids defined in Group 1.
- Provide a touch guard for surface temperatures of > 70°C. This touch guard must be designed in a way that the max. allowable ambient temperature on the unit is not exceeded.

Technical Data *mag-flux* MIS 1/D

Application field	see page 15
Mode of operation	see page 15
Measuring principle	Pulsed constant field (DC)

Inlet

Installation and nominal values	DN 500 (20") - DN 1000 (40") DN 1200 (48") - DN 2000 (80")
---------------------------------	---

Measuring accuracy

Error of measurement (under reference conditions)	± 3 % of the reading from 1 m/s to 5 m/s
--	---

Reference conditions

- Media temperature 25°C ± 5°C
- Ambient temperature 25°C ± 5°C
- Time for warm-up 30 min.
- Installation requirements
 - inlet path > 20 x DN
 - outlet zone > 10 x DN
 - installation vertical to the direction of flow
- Media clean water, not containing gases or solids
- Electric conductivity > 200 µS/cm
- Flow profile Rotation symmetric

Operational conditions

Operational conditions	see page 15
------------------------	-------------

Operating requirements

Max. operating pressure	max. 60°C / 140°F
-------------------------	-------------------

Pressure limits	10 bar / 145 psi
-----------------	------------------

<u>Protection class</u>	IP 68 / NEMA 6
-------------------------	----------------

Requirements on the media

Media type	clean and contaminated media
------------	------------------------------

Min. conductivity of media	> 20 µS/cm
----------------------------	------------

Flow rate

- Min. measuring range 0 - 1 m/s
- Max. measuring range 0 - 5 m/s

Specifications

Design	remote version with attached cable, 5m long
--------	--

Weight (without fitting aid)	approx. 3 kg
------------------------------	--------------

Sensor material

- Sensor body PVC
- Electrodes mat. No. 1.4571 (316Ti)
- gaskets Perbunan (Buna N)

Material of fitting aid	Steel, stainless steel, PVC, PP
-------------------------	---------------------------------

Technical Data *mag-flux* MIS 2/15

Application field	see page 15
Mode of operation	see page 15
Measuring principle	Pulsed constant field (DC)

Inlet

Installation and nominal values	DN 200 (8") - DN 400 (16") DN 500 (20") - DN 1000 (40")
---------------------------------	--

Accuracy

Error of measurement (under reference conditions)	± 3 % of the reading From 1 m/s to 10 m/s
--	--

Reference conditions

- Media temperature 25 °C ± 5°C
- Ambient temperature 25 °C ± 5°C
- Time for warm-up 30 min.
- Installation conditions
 - inlet path > 20 x DN
 - outlet zone > 10 x DN
 - installation vertical to the direction of flow
- Media clean water, not containing gases or solids
- Electric conductivity > 200 µS/cm
- Flow profile Rotation symmetric

Operational conditions

Operational conditions	see page 15
------------------------	-------------

Operating requirements

Max. operating pressure	max. 100°C / 212°F
-------------------------	--------------------

Pressure limits	20 bar (290 psi) / to 50°C (122°F) 10 bar (290 psi) / to 50°C (122°F)
-----------------	--

<u>Protection class</u>	IP 68 / NEMA 6
-------------------------	----------------

Requirements on the media

Media type	clean and contaminated media
------------	------------------------------

Min. conductivity of media	> 20 µS/cm
----------------------------	------------

Flow rate

- Min. measuring range 0 - 1 m/s
- Max. measuring range 0 - 10 m/s

Specifications

Design	remote version with attached cable, 5m long
--------	--

Weight (without fitting aid)	approx. 1,5 kg
------------------------------	----------------

Sensor Material

- Sensor body PVDF
- Electrodes mat. No. 1.4571 (316Ti)
- gaskets Viton
- Flange cover mat. No. 1.4571 (316Ti)

Material of fitting aid	Steel, stainless steel, PVC, PP
-------------------------	---------------------------------

Electrical Connection

Use the cable ends of the sensor to connect to the transmitter, see diagram in Fig. 2 and Fig. 3. If the sensor's cable is too short, a junction box with 2 separate cables up to max. 30 m (98.4 ft) long, may be used to extend the sensor cable (see also Measurement Requirements).

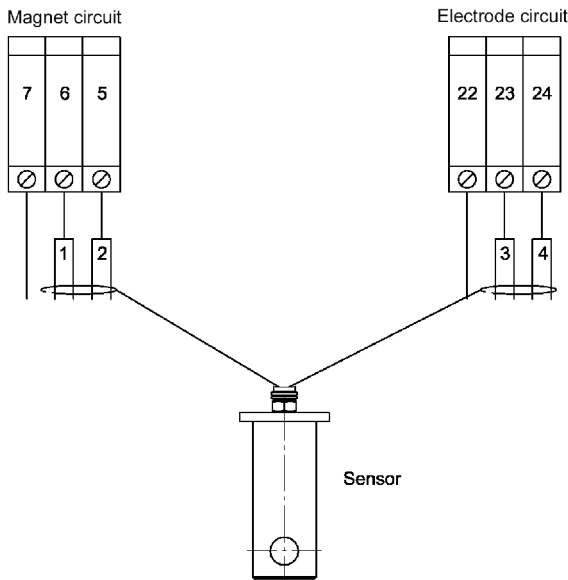

Fig. 2 Electrical connection for one sensor

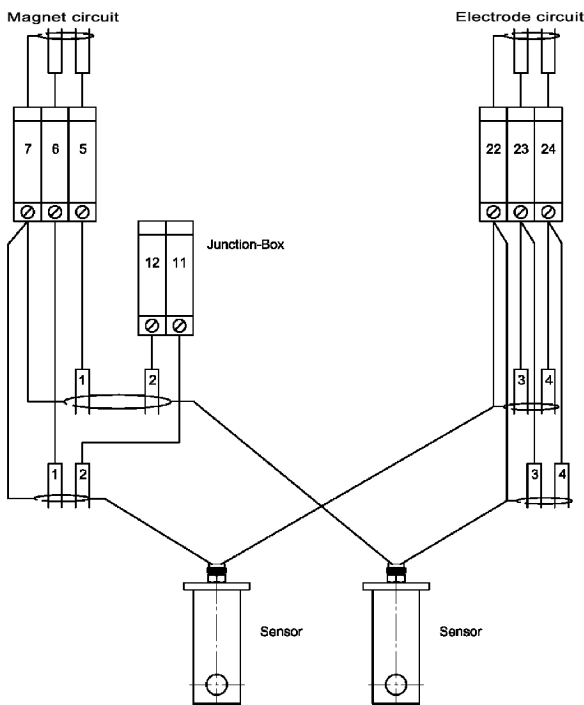

Fig. 3 Electrical connection for two sensors
(Determining the mean value)

Measurement Requirements

In order to maintain the mentioned measurement tolerances, the following prerequisites must be met:

1. Installation of the sensor per instructions.
2. The electrodes of sensor *mag-flux* S1 must be installed exactly vertical to the axis of flow, when using sensor *mag-flux* S2, the measuring channel must be exactly in the direction of the flow.
3. The sensor should be installed in an area of the pipe with a rotation-symmetric flow profile.

Note:

Where the distance of inflow and outflow paths are insufficient, 2 identical sensors may be used to determine the mean value and thereby achieving more accurate measurements. To do this, the sensors must be installed exactly opposite to each other. While using a special junction box, the sensors are connected with the transmitter. The signals are transmitted via two separate shielded cables (magnetic current $2 \times 1.0 \text{ mm}^2$ ($2 \times 0.0016 \text{ in}^2$), electrode current $2 \times 0.5 \text{ mm}^2$ ($2 \times 0.0008 \text{ in}^2$)). We recommend cable type LiYCY.

Recommendation:

When using nominal widths of $> \text{DN } 400$ ($> 16''$), it is recommended to attach 2 sensors opposing each other to the transmitter.

4. All sensor parameters must be fed into the transmitter.
5. Input of the inner pipe diameter into the transmitter.

Measurement Requirements

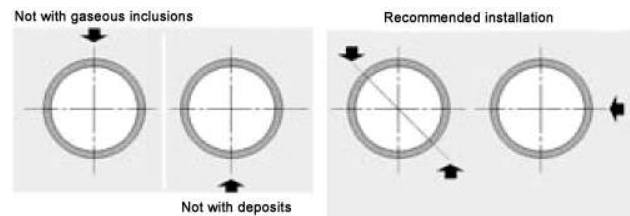

Fig. 4 Installation options

Inlet and Outlet

Ideally, the sensor should be installed in a pipeline with a sufficient straight run, both before and after the measuring point. Experience has shown, that an inflow path of at least 10 to $15 \times \text{DN}$ and an outflow zone of at least 5 to $7 \times \text{DN}$ is required. In extreme cases, e.g. Tee junctions, semi closed valves, or profile turbulences caused by DIN elbows, the inflow distance must be extended (min. approx. $25 \times d_i$, d_i = inner pipe diameter) or a flow conditioner must be installed.

Shortening the Pipeline

If the pipeline must be shortened, ideally, the angle should be $< 8^\circ$. This will avoid the falsification of any measurements and turbulences in the measured area. If the angle is larger than 8° , the inflow and outflow paths must be extended or flow conditioners should be used.

M
S1 und S2

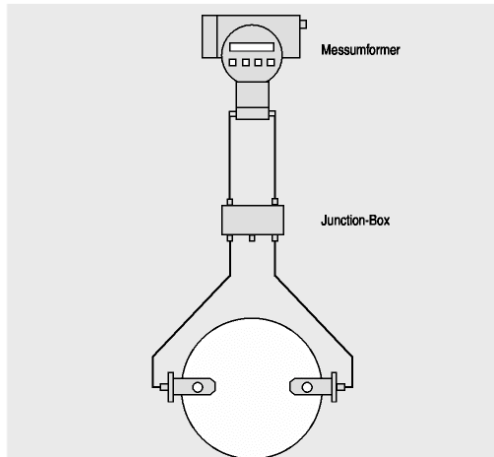

Fig. 5 Installation in pipes with large nominal diameters or adverse flow conditions.

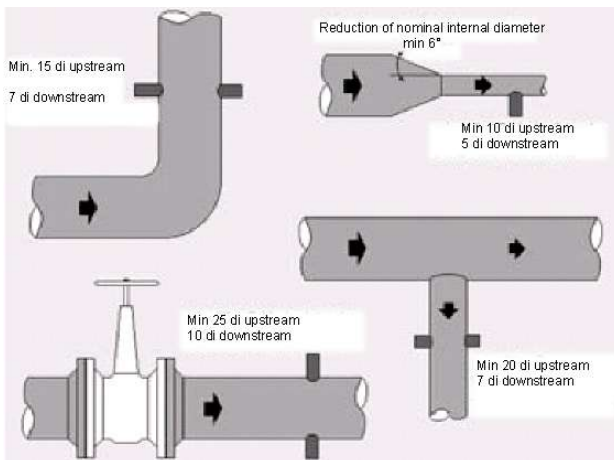

Fig. 6 Installation of 2 sensors if adverse flow profiles exist

Flow profile inside a pipeline

If an asymmetric flow exists inside the measuring tube, the accuracy of the measurement can be maintained by operating up to 2 sensors with one transducer (see Fig. 3). To determine the mean value, the solenoids of the sensor must be connected in series and the electric circuit of the electrodes must be connected in parallel.

When starting up the sensors, ensure the leads 3 (23) and 4 (24) are connected to clamp 23 and 24, and the respective transmitter indicates a positive flow.

Converting the sensor's constant when operating 2 sensors

If 2 sensors are used with one transmitter, a new combined sensor constant must be calculated first by using the individual sensor constants (CFH or C1 value). To do this, both sensor constants must be added and subsequently divided by a factor of 2. The result of this new sensor constant must then be entered into the transmitter.

Start-up

- Follow the diagram on how to connect the sensor with the transmitter.
- Follow the diagram on how to connect the transmitter with the mains power supply. Please observe the instructions applicable to the respective transmitter.
- Switch on the power and fill the pipeline with the respective medium.
- Enter the sensor's constant values CFH and ZPH or C1 into the transmitter.
- Enter the nominal diameter and the final value of the measurement area into the transmitter.
- The device is operational and displays the mean flow velocity or the flow rate inside the pipe.
- If the display indicates a negative value, the leads 3 and 4 (clamp 23 and 24) must be exchanged.

Inspecting the sensor

- When the sensor is removed and is in clean condition, the following electrical characteristics should be displayed:
- Resistance of the solenoid (between leads 1 and 2) approx. 8 to 20 Ω .
- Through-connection of all shielded cables with the sensor's ground.
- Through-connection of the electrodes to the respective lead ends (lead 3 and 4).
- Insulation resistance between the wiring of the electrode and the solenoid approx. 10 to 20 $M\Omega$.
- Insulation resistance between the wiring of electrodes 3 and 4 approx. 10 to 20 $M\Omega$.
- Insulation resistance between the wiring of the electrode or the solenoid against the screen 10 to 20 $M\Omega$

mag-flux MIS 1/D

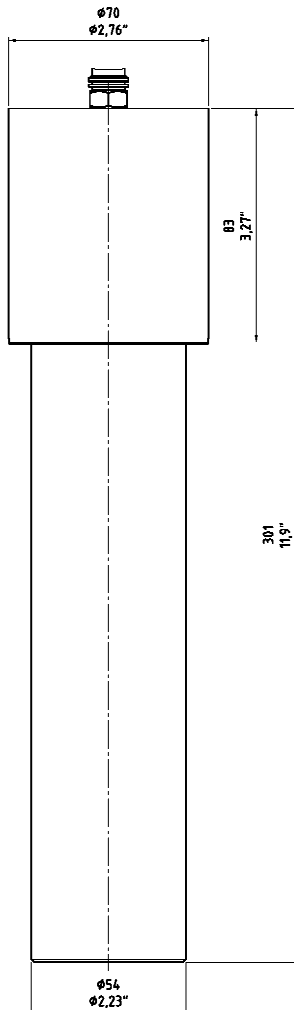

Fig. 6 Sensor *mag-flux* MIS 1/D

Important installation instructions

In order to display the accurate flow rate, it is imperative that the sensor's constant (see rating plate of the sensor) is entered into the transducer.

In general, it must be ensured during the installation as well as when parameterizing the transducer that the inner diameter is used or input.

The fitting aid for sensor *mag-flux* MIS 1/D must be installed in the pipeline in such a fashion as to ensure the centre of the measuring channel is 0.12 x di away from the pipe's inner wall. (di = inner pipe diameter)

When using 2 sensors, the sensors must be installed opposite from each other (see Fig. 4).

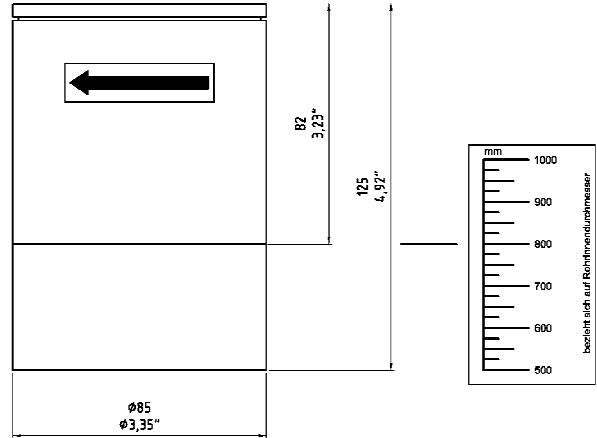

Fig. 7 Fitting aid *mag-flux* MIS 1/D for DN 200/8" up to DN 400/16"; scale displays inner diameter of pipe

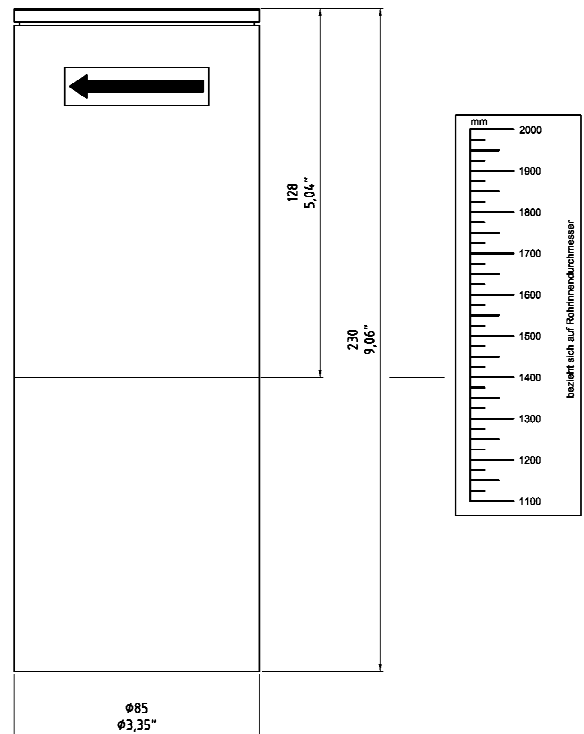

Fig. 8 Fitting aid *mag-flux* MIS 1/D for DN 1100/44" up to DN 2000/80"; scale displays inner diameter of pipe

Earthing

If plastic pipe or tubing with electrical insulation is used, an additional earthing ring bus must be mounted close to the sensor and connected electrically with the transmitter via an earthing cable dia. 4 mm² (0.0062 in²).

If using steel or stainless steel pipes, additional earthing is not necessary. The measuring media is earthed via the pipe.

Dimensions *mag-flux* MIS 2/15

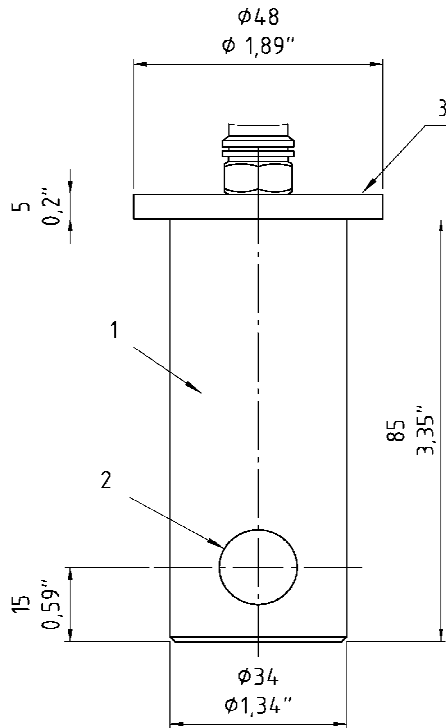

- 1 Sensorkörper PDF
- 2 Sondenkanal $\varnothing 15\text{mm} / 0,59''$
- 3 Flanschdeckel 1.4571 / 316 Ti

Fig. 9 Sensor *mag-flux* MIS 1/D

Important installation instructions

In order to display the accurate flow rate, it is imperative that the sensor's constant (see rating plate of the sensor) is entered into the transducer.

In general, it must be ensured during the installation as well as when parameterizing the transmitter that the inner diameter is used or input.

The fitting aid for sensor *mag-flux* MIS 2/15 must be installed into the pipeline in such a fashion as to ensure the centre of the measurement channel is 0.12 x di away from the pipe's inner wall (di = inner pipe diameter)

When using 2 sensors, the sensors must be installed opposite from each other (see Fig. 4).

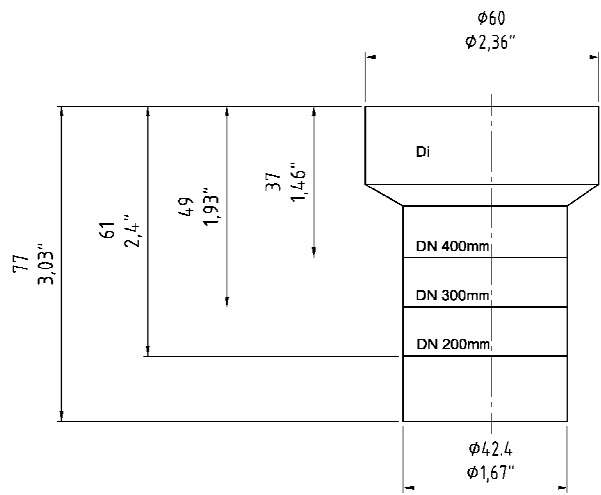

Fig. 10 Fitting aid *mag-flux* MIS 2/15 for DN 200/8" up to DN 400/16"; scale displays inner diameter of pipe

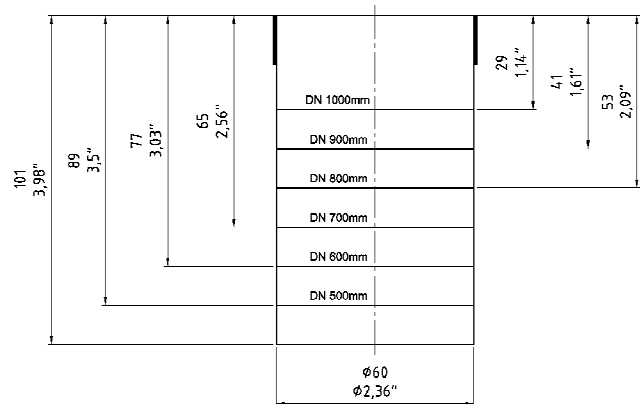

Fig. 11 Fitting aid *mag-flux* MIS 1/D for DN 500/20" up to DN 1000/40"; scale displays inner diameter of pipe

Earthing

If plastic pipe or tubing with electrical insulation is used, an additional earthing ring bus must be mounted close to the sensor and connected electrically with the transducer via an earthing cable dia. 4 mm² (0.0062 in²).

If using steel or stainless steel pipes, additional earthing is not necessary. The measuring media is earthed via the pipe.

Flow probe

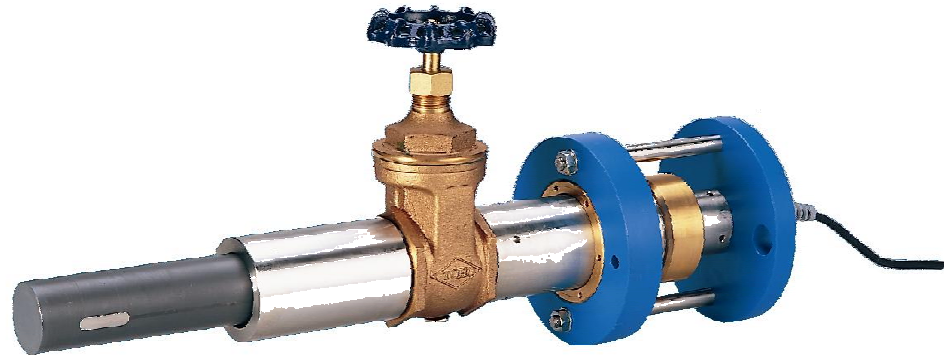

Fig. 12 Sensor *mag-flux* MIS 1/D with changeover tool SMD 3

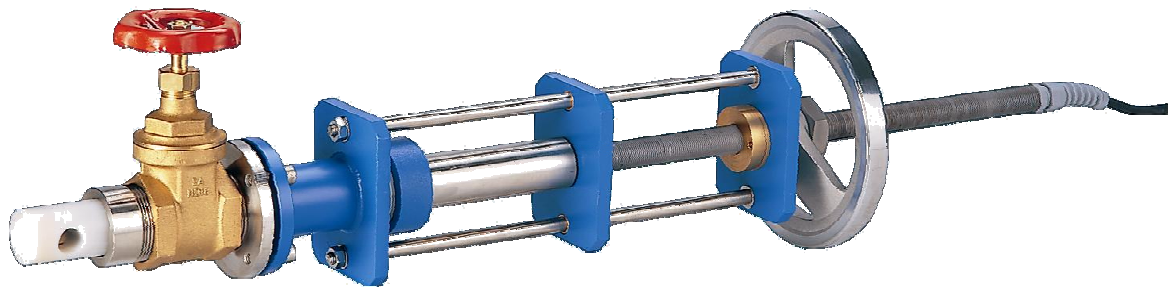

Fig. 13 Sensor *mag-flux* MIS 2/15 with changeover tool SMD2

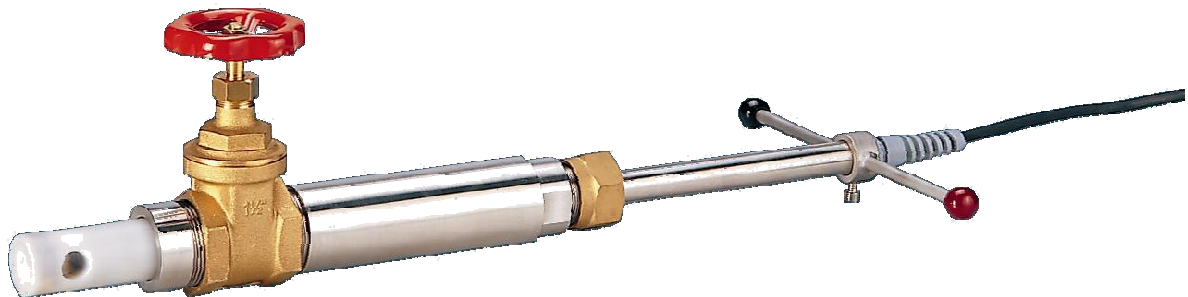

Fig. 14 Sensor *mag-flux* MIS 2/15 Flow-Probe

Ordering data

Electromagnetic flow Sensor *mag-flux* MIS 1/D

MAG5001-□□□□00-0AA0

Material Anschweisstützen	
• without	0 A
• Steel	
DN 500 - 1000/ 20" - 40"	1 A
DN 1100 - 2000/ 44" - 80"	2 A
DN 2500 /100"	3 A
• Stainless steel	
DN 500 - 1000/ 20" - 40"	1 B
DN 1100 - 2000/ 44" - 80"	2 B
DN 2500 /100"	3 B
Montagewerkzeug mit Anschweißstützen in Edelstahl	
• without	C
• sensor tool SMD 3 (for DN 500 - 1000)	A
• sensor tool SMD 3 (for DN 1000 - 2000)	B

Ordering data

Electromagnetic flow Sensor *mag-flux* MIS 2/15

MAG5002-□□□□00-0AA0

Material Anschweisstützen	
• without	0 A
• Steel	
DN 100 - 400/ 4" - 16"	1 A
DN 450 - 1000/ 18" - 40"	2 A
DN 1200 - 2000/ 48" - 80"	3 A
• Stainless steel	
DN 100 - 400/ 4" - 16"	1 B
DN 450 - 1000/ 18" - 40"	2 B
DN 1200 - 2000/ 48" - 80"	3 B
• PE	
DN 100 - 400/ 4" - 16"	1 C
DN 450 - 1000/ 18" - 40"	2 C
DN 1200 - 2000/ 48" - 80"	3 C
• PVC	
DN 100 - 400/ 4" - 16"	1 D
DN 450 - 1000/ 18" - 40"	2 D
DN 1200 - 2000/ 48" - 80"	3 D
Mounting tool	
• without	C
• sensor tool (for max. 2 bar)	A
• sensor tool (for max. 16 bar)	B
Flow- Probe	
• without	0
• Length 500 mm	2
• Length 700 mm	3
• Length 1000 mm	4

General Terms of Sale and Delivery

I. Scope of delivery duty

1. Our General Terms of Sale and Delivery apply to our offers and deliveries as far as they are not otherwise clearly stated or excluded in our offer. Our offers are valid for a period of 3 months calculated from the date of our offer as far as not otherwise indicated.

2. We assume that the placed order is accepted with the receipt of our written confirmation of order. Electronic, telephonic or verbal supplements must be confirmed in writing to be effective. The prices in our offer are only binding after the delivery of our confirmation of order. We reserve the right to adjust the prices after the submission of our offer.

3. Documents like illustrations, drawings and data lists belonging to the offer or the confirmation of order show only reference values. The indicated measuring range is kept by us as far as possible. We particularly reserve the right to deviations.

II. Price

Our prices do not include sales tax (VAT). The prices are valid for deliveries ex works excluding packing and freight. All spare part or single part orders with an invoice amount below € 50,- net are increased to this minimum invoice amount. For general modifications of the production costs, price adjustments are reserved for delivery times over 4 months as far as not otherwise agreed on, i.e. with a price escalator clause. Deliveries to foreign countries take place ex works Aachen. The freight costs are charged DDU except of other agreements.

III. Retention of title

1. The supplied goods remain our property until complete payment has been effected for all demands. This also applies where particular or all claims were entered to a current invoice and where the balance is drawn and accepted. The retention of title is then extended to the respective balance.

2. The customer is entitled to sell the goods supplied under retention of title to a third party in the normal course of business. Other orders, in particular mortgages or safety transfer are not permitted.

3. Already now the customer hands over all demands to us which will accrue for him from the resale against his buyers or against third parties independent of whether the product is resold without processing or after it. It is forbidden to the customer to make agreements with his buyers which exclude or impair our rights somehow. The customer particularly may not make any agreement that destroys or impairs the assignment in advance of the demand to us. Even after the assignment the customer is authorized to collect the demands handed over to us. However, our authorization to collect the demands personally remains untouched of this as long as the customer pays duly. We can demand that the customer announces us the assigned demands and their debtors, that he gives all details required for a collection, that he hands over the necessary documents and that he informs his debtors about the assignment.

4. Provided that the product delivered under reservation is resold with other goods which do not belong to us, the demand of the customer against his buyer is seen as assigned to the amount of the delivery price agreed on between us and the customer (including value added tax).

5. Processing or transformation of reserved goods by the customer is always made for us. If the reserved product is processed or mixed inseparably with other objects which do not belong to us, we receive a joint ownership of the new product proportional to the value of the reserved product and related to the legal relationship between us and the customer, to the other processed or mixed objects at the time of the processing or mixing. If the goods delivered under reservation are connected with other movable objects to a uniform thing or mixed inseparably and if the other thing can be regarded as main thing, we make the agreement that the customer assigns his joint ownership to us in case that the main thing belongs to him. The customer keeps the property or the joint ownership for us. The same as for the reserved product can be applied to the thing arising from processing, mixing or connection.

6. We are obliged to release the guarantees entitled to us in this respect as their value

exceeds the demands to be guaranteed for more than 10%.

IV. Terms of payment

1. For orders with a value exceeding 25.000,- €, a third of the amount must be paid in advance with receipt of the confirmation of order. The second third is due when the goods are ready for despatch. The remaining sum of the total amount must be paid at the latest 30 days on receipt of our invoice cash purely net.

2. The payments must be transferred to our indicated bank account cash or non-cash within 30 days after invoice date without any deduction.

3. Cheques and bills of exchange are only accepted after special agreements and only as payment but not as fulfillment regarding all collection and discount expenses. Passing on and prolongation are not considered as fulfillment.

4. In case of late payment we are entitled - after sending a reminder and considering the extension - to charge the costs arising from demands of a bank credit without special proof, at least however 2% over the respective discount rate of the state central bank.

5. The customer can only reckon up against our claims or assert a lien if the counter demand of the customer is undisputed or a legally valid title exists.

6. Partial deliveries are regarded as closed deliveries. Their invoices are subject to the above mentioned terms of payment.

V. Delivery period

Indicated delivery times are valid ex works on receipt of all documents. They are kept if shipments are ready for despatch meeting the deadline and if the customer was informed about it. Partial deliveries are permitted. The delivery periods are kept if possible without paying for the consequences of possible delays. Unforeseen events or acts of God, e.g. breakdowns, committee development, shortage of staff, war, mobilization, elementary events in our factory or of our sub-supplier, official interventions or regulations, difficulties during obtaining of raw material etc. prolong the delivery period appropriately or release us from the whole order - after agreement - provided that these events have a considerable effect on the fulfillment of the whole contract within the period stipulated or on some parts of the contract due soon. In important cases, the customer is informed as soon as possible after detection about beginning and end of such modifications by the factory management. If the customer cancels the current contract, the seller is allowed to demand a replacement of the actual damage or effort or at least 10% of the order value as cancellation charge alternatively insofar as the buyer does not prove a little damage. This regulation does not exclude a further reaching compensation demand on the part of the seller in case of non-compliance after delivery.

VI. Danger transition

The danger is passed at the latest to the customer with the dispatch of the parts to be delivered. If the dispatch is delayed by a behaviour of the customer, then the danger is passed to the customer with the communication of the dispatch readiness.

VII. Packing

The dispatch is carried out in the known and accepted packing which is calculated separately and not taken back. A special packing is only used on explicit request of the customer if the additional costs arising from it are reimbursed. Complaints about inadequate packing and their consequences only affect us if the type of packing did not comply with special regulations of the authority or the customer and which can be explained by their non-observance.

VIII. Guarantee

1. For the parts to be delivered/the performance we are liable for a period of 12 months after the time of the danger transition for the use of the materials indicated in our confirmation of order and for the expert execution, particularly for faultless parts without defects and for the existence of assured characteristics. Our guarantee obligation presupposes that the customer has met in writing the examination and rebuke obligations being incumbent upon him in accordance with §§ 377, 378 HGB (code of

commerce). Customer's complaints must always be submitted specified in writing.

2. In case of a well-founded complaint, we oblige ourselves to remove the defects by exchange or by rework of the parts complained about. We will pay the arising charges for an improvement or an exchange.

3. If we are not willing or not able for the improvement/substitute delivery within the bounds of removing the defect, particularly if the improvement/substitute delivery is delayed over adequate periods set to us, the customer is authorized to withdraw from the contract or to assert on reduction excluding further reaching claims. This also applies if we culpably break the obligation being incumbent upon us to remove the defects.

4. Damage compensation entitlements independent of their legal justification are excluded. However, this is not valid if there exists a written characteristic assurance which extends on the risk of consequent damages of a defect. Insofar as a property damage results for the customer as consequence of a lack of an assured characteristic, our compensation liability is restricted to the respective compensation delivery of our product personal liability insurers. Further reaching damage compensation complaints are only entitled to the customer if the damage was caused by us, our staff, representatives or fulfillment assistants intentionally or roughly negligent.

5. In principle, a defect elimination in the bounds of our guarantee obligation is only made in our factory after returning the part complained about post free or carriage and duty paid. The costs of the return including the costs of the substitute delivery must be paid by the customer. As far as the customer requests engineers, fitters, mechanics or other employees of our company due to suspected defects, the arising costs are charged to the customer as far as the customer's complaint proves to be not justifiable.

IX. Liability

1. Further reaching liabilities than those regulated under point VIII does not consist in the contract relationship between the customer and us and to be more precise without consideration for the respective legal basis.

2. Insofar as the liability opposite to us is excluded or limited, this is also valid with regard to the personal liability of our employees/fulfillment assistants.

3. Customer claims asserted against us outside of the guarantee are in lapse within 6 months calculated from the moment of danger transition/buying.

X. Right of withdrawal of the supplier

1. We reserve the right to withdraw from the contract without compensation obligation in case of unforeseen events as described under point V of the delivery.

2. If required, we are authorized to demand certainty for the service in return or to withdraw from the contract crediting the made charges even after conclusion of the sales contract.

XI. Place of jurisdiction

1. Place of fulfillment is Aachen, court jurisdiction for both parties is Aachen. The agreement on the court jurisdiction is only valid for contract parties who are not merchants or who belong to the tradesmen described in § 4 HGB (code of commerce) if claims are asserted in the way of the dunning proceeding (§§ 688 ZO).

2. The contract and its interpretation are subject to the law of the Federal Republic of Germany.

XII. Transferability and liability of the contract

1. Customer and supplier may transfer their contract rights to third parties only by mutual consent.

2. The contract is binding even with a legal ineffectiveness of single points of its conditions.

3. Contrary terms of delivery and payment are not accepted insofar as they are not noted down particularly in writing.

Version: 12/2003