



Fig. 1 F VA Minix variable area meter

Application

The F VA Minix variable area meters are used to measure the volume of transparent liquids and gases passing through closed piping. The built-in needle valve permits manual control of flow rates. Standard scales are available for liquids with a density of 1 kg/l (62.43 lb/cu.ft) and for air. The scales must be recalculated for all other media depending on the physical characteristics.

Design and operation

The main components of the F VA Minix variable area meters are the glass variable-area flow tube with float, the fitting, the connection parts and the valve. The flow is displayed directly on the scale present on the flow tube (e.g. in l/h) and is read at the position of the float's widest diameter.

Special features

- Product scales for liquids and gases
- Rugged versions with various materials
- Can be used for high pressures
- Suitable for panel mounting and battery assembly

Connection and mode of operation

The variable area meter must be fitted vertically and without tension. Reductions or expansions in the pipe diameter upstream or downstream of the variable area meter have no influence on the accuracy. With liquids, the valve can be fitted at the top or bottom. With gases, the valve can only be fitted at the top so as to prevent pulsations resulting from compression. Since variable area meter respond extremely sensitively to changes in flow, control elements should always be adjusted slowly.

The calibration has been carried out for defined media conditions. Deviations in the density, pressure or temperature of gases, or in the density or viscosity of liquids, result in measurement errors. It is essential to observe the calibration conditions. When ordering, it is therefore essential to provide data on the medium, density and viscosity at the operating temperature and pressure if the conditions deviate from the standard values in the measuring range tables. With gases, it is additionally necessary to specify the exact reference point of the pressure (pressure above atmospheric, or absolute pressure).

- 1 Fitting
- 2 Connection unit with valve insert
- 3 Valve spindle
- 4 Locking screw
- 5 O-ring gasket
- 6 Threaded plug
- 7 Rotary knob
- 8 O-ring gasket
- 9 Limit stop
- 10 Limit stop washer ¹⁾
- 11 Gasket
- 12 Float
- 13 Flow tube
- 14 Connection unit
- 15 O-ring gasket
- 16 Pressure plug
- 17 Screw cap
- 18 O-ring gasket ¹⁾
- 19 Valve seat ¹⁾
- 20 Spacer sleeve ¹⁾
- 21 Circlip ¹⁾

¹⁾ Only with MINIX MA 152 and MA 302

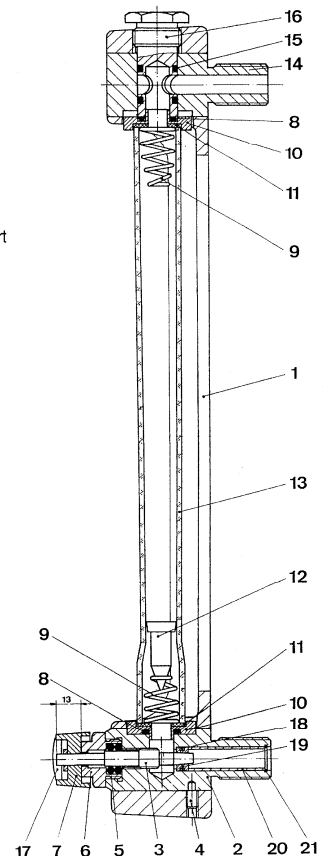

Fig. 2 F VA Minix, design

Note of application

The operator of these measuring instruments is responsible for suitability, proper use and corrosion resistance of the used materials with regard to the measuring material. It must be ensured that the materials selected for the meter parts in contact with the medium are suitable for the used process media. The unit may only be used within the pressure and voltage limits specified in the operating instructions. Before replacing the measuring tubes, check that the meter is free of hazardous media and pressures. The flowmeter meets the requirements of the PED 97/23/EG as stated in the table on page 2.

Variable area meter F VA Minix

Technical Data

Application	See page 1
Mode of operation	See page 1
Measuring principle	Float
Input	
Flow	Vertically upwards
Pressure limit	Max. 10 bar / 145 psi
Rated operating conditions	
Ambient conditions	
Temperature limits	-10 to +70 °C (14 to 158 °F)
Medium conditions	
• Accuracy	Class 2,5 (according to VDE/VDI 3513, sheet 2)
• Measuring range	Dependent on flow tube and medium (see measuring range table)
• Dimensions for meas. variable	l/h
Design	
Connections	Male thread DIN/NPT 1/4" or 1/2" or hose bushing (DIN 3254)
Material	
• Flow tube	Borosilicate glass
• Connection	Stainless steel mat.No. 1.4571/316Ti
• Float	Aluminium, stainless steel mat.No. 1.4571/316Ti
• Gasket	Viton
• Fitting	Aluminium
Weight	
• MA 70	0,5 kg (1,10 lb)
• MA 151	0,5 kg (1,10 lb)
• MA 152	1,5 kg (3,31 lb)
• MA 301	0,5 kg (1,10 lb)
• MA 302	1,7 kg (3,75 lb)
Certificates and approvals	
Classification according to PED 97/23/EC	For gases of fluid group 1 and liquids of fluid group 1; complies with requirements of article 3, paragraph 3 (sound engineering practice SEP)

Dimensional drawings

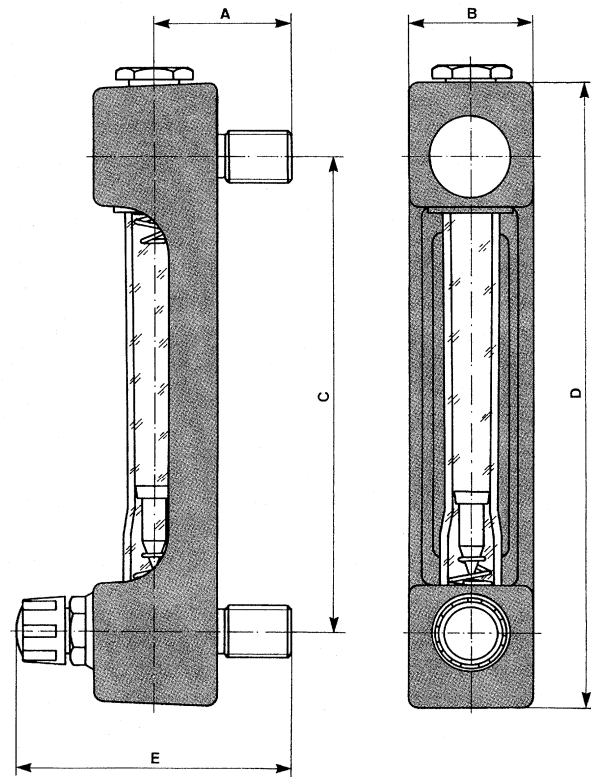

Fig. 3 Minix, dimensions

Type	Dimension in mm (inch)									
	A ¹⁾		B		C		D		E ¹⁾	
MA 70	38	(1,50)	27	(1,06)	90	(3,54)	120	(4,72)	76	(2,99)
MA 151	38	(1,50)	31	(1,22)	170	(6,69)	202	(7,95)	76	(2,99)
MA 152	55	(2,17)	50	(1,97)	190	(7,48)	250	(9,84)	118	(4,65)
MA 301	38	(1,50)	31	(1,22)	320	(12,60)	352	(13,86)	76	(2,99)
MA 302	55	(2,17)	30	(1,18)	340	(13,39)	400	(15,75)	118	(4,65)

¹⁾ Dimensions A and E only apply to the standard design with DIN male thread, brass.

Measuring range

Note:

With liquids, only available for media with viscosity = 1 mPa·s (1cp) !

Type	Connection		Flow tube	Measuring range			
	Male thread	Hose bushing		Liquids		Gases	
				ρ = 1 kg/l (62,43 lb/cu.ft), viscosity = 1 mPa·s (1cp)		air at p _{abs} = 1,013 bar (14,69 psi) and T=0°C (32°F), ρ=1,293 kg/m ³ , v=0,0181 mPa·s	
				Float 1.4571/316Ti		Float, aluminium	
			l/h	USgpm	l/h	scfm	
MA70	1/4"	10 mm (0,39 inch)	70.01	0,1 to 1	(0,0004 to 0,0044)	2,0 to 20	(0.0012 to 0.012)
			70.02	0,2 to 2	(0,0008 to 0,0088)	4,0 to 40	(0.0024 to 0.024)
			70.05	0,5 to 5	(0,0022 to 0,022)	9,0 to 90	(0.0053 to 0.053)
			70.11	1 to 10	(0,0044 to 0,044)	20 to 200	(0.012 to 0.118)
			70.12	2 to 20	(0,0088 to 0,088)	40 to 400	(0.024 to 0.235)
			70.13	3 to 30	(0,0132 to 0,132)	47 to 470	(0.028 to 0.277)
			70.14	4 to 40	(0,0176 to 0,176)	-	-
			70.15	5 to 50	(0,022 to 0,22)	-	-
MA151	1/4"	10 mm (0,39 inch)	151.3	0,1 to 1,5	(0,0004 to 0,0066)	2,5 to 25	(0.001 to 0.015)
			151.5	0,2 to 2,5	(0,0008 to 0,011)	4 to 45	(0.002 to 0.026)
			151.10	0,5 to 5	(0,0022 to 0,022)	8 to 80	(0.005 to 0.047)
			151.25	1 to 12	(0,0044 to 0,053)	20 to 200	(0.012 to 0.118)
MA152	1/2"	13 mm (0,51 inch)	152.5	5 to 55	(0,022 to 0,242)	90 to 900	(0.053 to 0.530)
			152.10	10 to 100	(0,044 to 0,44)	150 to 1500	(0.088 to 0.883)
			152.20	15 to 210	(0,066 to 0,92)	300 to 3000	(0.177 to 1.766)
			152.30	30 to 300	(0,132 to 1,32)	500 to 5000	(0.294 to 2.943)
			152.40	40 to 420	(0,176 to 1,85)	600 to 6000	(0.353 to 3.531)
			152.60	60 to 530	(0,26 to 2,33)	750 to 7500	(0.441 to 4.414)
MA301	1/4"	10 mm (0,39 inch)	A1	0,1 to 1,0	(0,0004 to 0,004)	2 to 20	(0.001 to 0.012)
			A3	0,3 to 3	(0,0013 to 0,013)	5 to 50	(0.003 to 0.029)
			A5	0,5 to 5	(0,0022 to 0,022)	9 to 90	(0.005 to 0.053)
			A10	1 to 10	(0,0044 to 0,044)	16 to 160	(0.009 to 0.094)
			A25	2,5 to 25	(0,011 to 0,11)	40 to 400	(0.024 to 0.235)
MA302	1/2"	13 mm (0,51 inch)	B30	3 to 30	(0,0132 to 0,132)	50 to 500	(0.029 to 0.294)
			B40	4 to 40	(0,0176 to 0,176)	65 to 650	(0.038 to 0.383)
			B50	5 to 50	(0,022 to 0,22)	80 to 800	(0.047 to 0.471)
			B65	6,5 to 65	(0,029 to 0,29)	110 to 1100	(0.065 to 0.647)
			B80	8 to 80	(0,035 to 0,35)	140 to 1400	(0.082 to 0.824)
			B100	10 to 100	(0,044 to 0,44)	160 to 1600	(0.094 to 0.942)
			C125	12,5 to 125	(0,055 to 0,55)	200 to 2000	(0.118 to 1.177)
			C160	16 to 160	(0,070 to 0,70)	300 to 3000	(0.177 to 1.766)
			C200	20 to 200	(0,088 to 0,88)	360 to 3600	(0.212 to 2.119)
			C250	24 to 240	(0,106 to 1,06)	400 to 4000	(0.235 to 2.354)
			C315	31,5 to 315	(0,139 to 1,39)	500 to 5000	(0.294 to 2.943)
			C400	40 to 400	(0,176 to 1,76)	640 to 6400	(0.377 to 3.767)
			C500	50 to 500	(0,22 to 2,20)	800 to 8000	(0.471 to 4.709)

Variable area meter F VA Minix

Selection and ordering data for liquids

$\rho = 1 \text{ kg/l}$ (62,43 lbs/cu.ft), viscosity = 1 mPa.s (1cp)

Flow tube size	Measuring range in l/h (Usgpm)	Ordering code
MA 70		
70.01	0,1 to 1 (0,0004 to 0,0044)	1 A C
70.02	0,2 to 2 (0,0008 to 0,0088)	2 A C
70.05	0,5 to 5 (0,0022 to 0,022)	3 A C
70.11	1 to 10 (0,0044 to 0,044)	4 A C
70.12	2 to 20 (0,0088 to 0,088)	5 A C
70.13	3 to 30 (0,0132 to 0,132)	6 A C
70.14	4 to 40 (0,0176 to 0,176)	7 A C
70.15	5 to 50 (0,022 to 0,22)	8 A C
MA 151		
151.3	0,1 to 1,5 (0,0004 to 0,0066)	1 B C
151.5	0,2 to 2,5 (0,0008 to 0,011)	2 B C
151.10	0,5 to 5 (0,0022 to 0,022)	3 B C
151.25	1 to 12 (0,0044 to 0,053)	4 B C
MA 152		
152.5	5 to 55 (0,022 to 0,242)	1 C C
152.10	10 to 100 (0,044 to 0,44)	2 C C
152.20	15 to 210 (0,066 to 0,92)	3 C C
152.30	30 to 300 (0,132 to 1,32)	4 C C
152.40	40 to 420 (0,176 to 1,85)	5 C C
152.60	60 to 530 (0,26 to 2,33)	7 C C
MA 301		
A 1	0,1 to 1 (0,0004 to 0,004)	1 D C
A 3	0,3 to 3 (0,0013 to 0,013)	2 D C
A 5	0,5 to 5 (0,0022 to 0,022)	3 D C
A 10	1 to 10 (0,0044 to 0,022)	4 D C
A 25	2,5 to 25 (0,011 to 0,11)	5 D C
MA 302		
B 30	3 to 30 (0,0132 to 0,132)	1 E C
B 40	4 to 40 (0,0176 to 0,176)	2 E C
B 50	5 to 50 (0,022 to 0,22)	3 E C
B 65	6,5 to 65 (0,029 to 0,29)	4 E C
B 80	8 to 80 (0,035 to 0,35)	5 E C
B 100	10 to 100 (0,044 to 0,44)	6 E C
C 125	12,5 to 125 (0,055 to 0,55)	1 F C
C 160	16 to 160 (0,07 to 0,7)	2 F C
C 200	20 to 200 (0,088 to 0,88)	3 F C
C 250	24 to 240 (0,106 to 1,06)	4 F C
C 315	31,5 to 31 (0,139 to 1,39)	5 F C
C 400	40 to 400 (0,176 to 1,76)	6 F C
C 500	50 to 500 (0,22 to 2,20)	7 F C
Gasket material		
• Viton 4		
Connection type		
• female thread DIN, 1.4571/316Ti B		
• female thread NPT, 1.4571/316Ti D		
• hose bushing, 1.4571/316Ti F		
Further designs		
Please add "-Z" to order no. and specify order code		
Y01	Medium (always required if density is not 1 kg/l if density is not 1 kg/l (62,43 lb/cu.ft) specify in plain text Medium, measuring range, dimension, density with dimension, viscosity with dimension, operating temperature, operating pressure with engraved scale (>90°C (>194°F))	
Y02	with engraved scale (>90°C (>194°F))	
Y04	Silicone-free version	
Y05	Medium: water viscosity: 1mPas (cp), density 1 kg/l (62,43 lb/cu.ft)	
B06	with calibration certificate	
Y99	Special version, specify in plain text	

Selection and ordering data for air

air at $p_{abs} = 1,013 \text{ bar}$ (14,69 psi) and $T = 20^\circ\text{C}$ (68°F),
 $\rho = 1,293 \text{ kg/m}^3$, $\nu = 0,0181 \text{ mPa.s}$

Flow tube size	Measuring range in l/h (scfm)	Ordering code
MA 70		
70.01	2 to 20 (0,0012 to 0,012)	1 A A
70.02	4 to 40 (0,0024 to 0,024)	2 A A
70.05	9 to 90 (0,0053 to 0,053)	3 A A
70.11	20 to 200 (0,012 to 0,118)	4 A A
70.12	40 to 400 (0,024 to 0,235)	5 A A
70.13	47 to 470 (0,028 to 0,277)	6 A A
MA 151		
151.3	2,5 to 25 (0,001 to 0,015)	1 B A
151.5	4 to 45 (0,002 to 0,026)	2 B A
151.10	8 to 80 (0,005 to 0,047)	3 B A
151.25	20 to 200 (0,012 to 0,118)	4 B A
MA 152		
152.5	90 to 900 (0,053 to 0,53)	1 C A
152.10	150 to 1500 (0,088 to 0,883)	2 C A
152.20	300 to 3000 (0,177 to 1,766)	3 C A
152.30	500 to 5000 (0,294 to 2,943)	4 C A
152.40	600 to 6000 (0,353 to 3,531)	5 C A
152.60	750 to 7500 (0,441 to 4,414)	7 C A
MA 301		
A 1	2 to 20 (0,001 to 0,012)	1 D A
A 3	5 to 50 (0,003 to 0,029)	2 D A
A 5	9 to 90 (0,005 to 0,053)	3 D A
A 10	16 to 160 (0,009 to 0,094)	4 D A
A 25	40 to 400 (0,024 to 0,235)	5 D A
MA 302		
B 30	50 to 500 (0,029 to 0,294)	1 E A
B 40	65 to 650 (0,038 to 0,383)	2 E A
B 50	80 to 800 (0,047 to 0,471)	3 E A
B 65	110 to 1100 (0,065 to 0,647)	4 E A
B 80	140 to 1400 (0,082 to 0,824)	5 E A
B 100	160 to 1600 (0,094 to 0,942)	6 E A
C 125	200 to 2000 (0,118 to 1,177)	1 F A
C 160	300 to 3000 (0,177 to 1,766)	2 F A
C 200	360 to 3600 (0,212 to 2,119)	3 F A
C 250	400 to 4000 (0,235 to 2,354)	4 F A
C 315	500 to 5000 (0,294 to 2,943)	5 F A
C 400	640 to 6400 (0,377 to 3,767)	6 F A
C 500	800 to 8000 (0,471 to 4,709)	7 F A
Gasket material		
• Viton 4		
Connection type		
• female thread DIN, 1.4571/316Ti B		
• female thread NPT, 1.4571/316Ti D		
• hose bushing, 1.4571/316Ti F		
Further designs		
Please add "-Z" to order no. and specify order code		
Y01	Medium (always required if density is not 1 kg/l if density is not 1 kg/l (62,43 lb/cu.ft) specify in plain text Medium, measuring range, dimension, density with dimension, viscosity with dimension, operating temperature, operating pressure with engraved scale (>90°C (>194°F))	
Y02	with engraved scale (>90°C (>194°F))	
Y04	Silicone-free version	
Y05	Medium: water viscosity: 1mPas (cp), density 1 kg/l (62,43 lb/cu.ft)	
B06	with calibration certificate	
Y99	Special version, specify in plain text	