



Fig 1 Electromagnetic flow sensor *mag-flux SK* with inductive transmitter *mag-flux M1*

Application domain

These electromagnetic flow sensors (MID) are suitable for measuring standard applications.

The special design of this electromagnetic flowmeter (MID) is in particular of his extremely robust and compact but light-weight construction used to built-in plastic pipes without reinforcement. Integrated earthing rings guarantee best measuring results and ensure also a safe connection built-in in steel pipes.

The main applications of the flow sensor *mag-flux S* can be found in the following fields:

- Water and sewage plants
- Food- and beverage industry
- Steel industry
- Energy industry

The *mag-flux M1* is a microprocessor controlled and programmable transmitter with pulsed constant field. It is designed for flow velocities up to 10 m/s.

The device can be used to perform measurements with any liquid with a minimum conductivity of 3 $\mu\text{S}/\text{cm.}$, providing that the sensor's material is suitable for the fluid.

Special features

Sensor (MID)

- Extremely compact and light weighted design
- Suitable for installation in plastic or steel pipes
- Sensor firmly connected to stainless steel rings
- No other earthing required
- No movable parts

Transmitter

- High-speed signal processing by 16-bit microcontroller
- Easy navigation with a two-line display (Option)
- Self-monitoring system
- Analog output (0/4-20 mA) and digital outputs (pulse, device status, limit, frequency)
- Internal simulation for all output values
- multilingual menus

Application note

- The magnetic-inductive metering system is entirely suitable for the measurement of volume flow rates of conductive liquids.
- Before replacing a device ensure that the meter is pressureless and free from hazardous media.
- The operation of the device is only valid within the temperature range specified on the rating plate.
- The limits for the electrical connections of the transmitter are specified on the rating plate and have to be observed strictly.
- The transmitter is compliant with the EMC Directive 89/336/EEC und low-voltage Directive 73/23/EWG.
- Improper installation and use of the transmitter (metering system) could cause a loss of warranty.
- The sensor must not be affected by external loads
- The units are designed for predominantly recumbent load.
- The flowmeter complies with the requirements of the Pressure Equipment Directive 97/23/EC, article 3, paragraph 3. The most hazardous permissible media are the fluids defined in group 1.
- Provide a touch guard for surface temperatures of $> 70^{\circ}\text{C}$. This touch guard must be designed in a way that the max. allowable ambient temperature on the unit is not exceeded.

Connection and system design

The flange-less sensor is firmly screwed between flange connections. It can be used for EN1092-1 PN6 / PN10 / PN16 / PN25 / PN40 and ANSI B16.5 150RF and 300RF

Electromagnetic flow Sensor *mag-flux* SK (compact version)

Operating principle

According to Faraday's law of electromagnetic induction, an electrical voltage is generated by the sensor which is proportional to the velocity of the liquid inside the measuring tube.

This voltage is gained and processed by the *mag-flux* M1 and transduced into analog and digital outputs.

A control unit is available as an additional option which provides a local display and the opportunity to customize the transmitter's configuration.

The *mag-flux* M1 is prepared for HART® communication. An appropriate version is available on request.

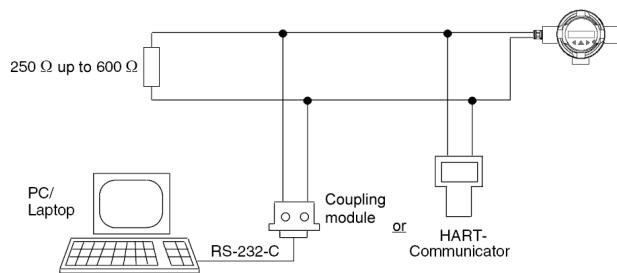

Fig 2 Electrical connection for HART® communication, schematic diagram

Technical Data

Mode of operation and design

Measuring principle	magnetic inductive with pulsed constant field (PDC)
Magnetic field excitation	Internal clock with DC supply 1,56 Hz / 3,125 Hz / 6,25 Hz / 12,5 Hz / 25 Hz

Operating conditions

Mounting position	vertical or horizontal
permissible ambient temperature	-15°C - 50°C / 5 - 122 °F
permissible operating temperature	-15°C - 60°C / 5 - 140°F Processtemp.: max. 60 °C (104 °F)
Control unit (<i>mag-flux</i> M1)	0 ... +50 °C (32 ... 122 °F)

Pressure/temperature limits with PVC- connection (DIN 8062)	Temperature		Max. pressure	
	°C	°F	Bar	Psi
	10	50	18	261
	20	68	16	232
	30	86	13	189
	40	104	10	145
	50	122	6	87
	60	140	4	58

Pressure/temperature limits with PVDF- connection (DIN 8062)	Temperature		max. pressure	
	°C	°F	Bar	Psi
	10	50	18	261
	20	68	16	232
	30	86	13	189
	40	104	11	160
	50	122	9	80
	60	140	8	65

Protection class IP 67 (NEMA 4x)

Electromagnetic compatibility (EMC)

- Emitted interference acc. to EN 61000-6-3:2001 (for use in home and industry)
- Noise immunity acc. to EN 61000-6-2:1999 (for use in industry)
NAMUR NE21 (Ver. 10.02.2004)

Outputs

Electrical isolation outputs electrically isolated from each other and from the power supply

Current output

- Signal
 - Signal range 0 ... 20 mA / 4 ... 20 mA, selectable
 - Failure signal > 22 mA oder < 3,8 mA, can be switched
- Load
 - Output < 600 Ω
 - for HART communication ≥ 250 Ω

Communication via analog output with PC coupling module or HART Communicator HART, version 7.0

- Protocol

Digital output

- Signal
 - Design Optocoupler, passive
 - Rated values max. 1,8W, max. 30 V, 60 mA

§ Output configuration

- Pulse
 - Significance ≤ 1000 pulses/s
 - Pulse width ≥ 0,1 ms (max. 2s), selectable
- Frequency
- Signal range 0 ... 1 kHz

Digital output 2

- Signal
 - Design Optocoupler, passive
 - Rated values max. 1,8W, max. 30 V, 60 mA
- Output configuration Status output: forward flow, reverse Flow, MIN, MAX, Alarm (selectable)

Measuring accuracy (under reference conditions)

Pulse output	± 0,5 % of measured value 0,25 m/s to 10 m/s ±0,05 % per 10 K
Current output	± 0,5 % of measured value 0,25 m/s to 10 m/s ±0,1 % per 10 K
Reproducibility	± 0,15 % of measured value 0,25 m/s to 10 m/s

Centering unit

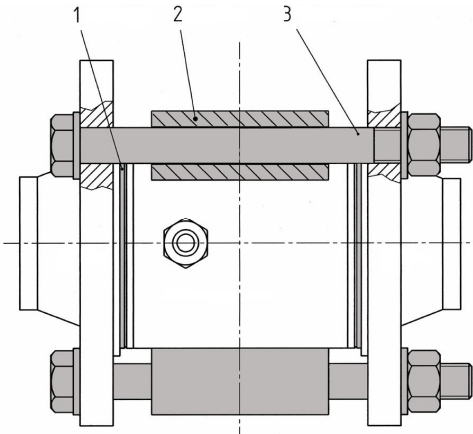

1 – gaskets (Viton); 2x

2 – centering sleeves (BunaN)

3 – screws and nuts
(steel or stainless steel)

Dimensions

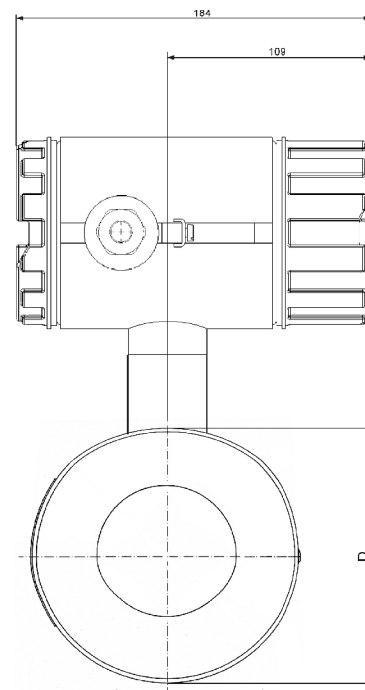
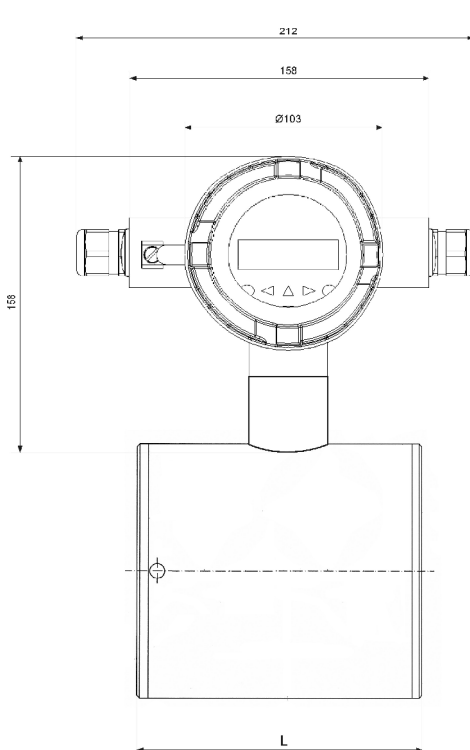

Nennweite		L	D	Gewicht
mm	(inch)	mm	mm	kg
25	1"	74	63,5	3,4
32	1¼"	105	73	5
40	1½"	105	82,5	5
50	2"	105	95	5
65	2½"	150	114,3	8,2
80	3"	150	127	8,2
100	4"	150	146	8,2

Electromagnetic flow Sensor *mag-flux* SK (compact version)

Order code

Electromagnetic flow Sensor *mag-flux* SK with M1

MAG 5 4 1 1 - 0 -

Metering tube materials and nominal diameters

• Metering tube made of PVC, DN 25 / ANSI 1"	1 F
• Metering tube made of PVC, DN 32 / ANSI 1 1/4"	1 G
• Metering tube made of PVC, DN 40 / ANSI 1 1/2"	1 H
• Metering tube made of PVC, DN 50 / ANSI 2"	1 J
• Metering tube made of PVC, DN 65 / ANSI 2 1/2"	1 K
• Metering tube made of PVC, DN 80 / ANSI 3"	1 L
• Metering tube made of PVC, DN 100 / ANSI 4"	1 M
• Metering tube made of PVDF, DN 25 / ANSI 1"	2 F
• Metering tube made of PVDF, DN 32 / ANSI 1 1/4"	2 G
• Metering tube made of PVDF, DN 40 / ANSI 1 1/2"	2 H
• Metering tube made of PVDF, DN 50 / ANSI 2"	2 J
• Metering tube made of PVDF, DN 65 / ANSI 2 1/2"	2 K
• Metering tube made of PVDF, DN 80 / ANSI 3"	2 L
• Metering tube made of PVDF, DN 100 / ANSI 4"	2 M

centering assembly

• without	A
• steel, DN 25 / 1"	D
• steel, DN 32 / 1 1/4"	E
• steel, DN 40 / 1 1/2"	F
• steel, DN 50 / 2"	G
• steel, DN 65 / 2 1/2"	H
• steel, DN 80 / 3"	J
• steel, DN 100 / 4"	K
• stainless steel, DN 25 / 1"	N
• stainless steel, DN 32 / 1 1/4"	P
• stainless steel, DN 40 / 1 1/2"	Q
• stainless steel, DN 50 / 2"	R
• stainless steel, DN 65 / 2 1/2"	S
• stainless steel, DN 80 / 3"	T
• stainless steel, DN 100 / 4"	U

Materials metering tube connection

• mat.No. 1.4305	1
• other materials	9

Power supply

• AC 230 V, 50/60 Hz	1
• AC 115 V, 50/60 Hz	2
• DC 18-36 V	3

Output / communication

• 4 - 20 mA	A
• 4 - 20 mA with HART protocol	B

Operator display and keypad

• without	A
• with	B

Cable glands

• M20/M16 x 1.5	1
• 1/2" - 14 NPT	2

Further designs:

• TAG plate inscription in english	B11
• with 3- point calibration certificate	B06
• with 6- point calibration certificate	B07
• Measuring range, specify in plain text	Y01
• Silicone-free materials	Y04
• Measuring-point number	Y15
• Measuring-point description	Y16
• TAG plate stainless steel	Y17