

# Flowmeters

**M E C O N**  
FLOW-CONTROL-SYSTEMS

Flow sensors 711/D, 911/D

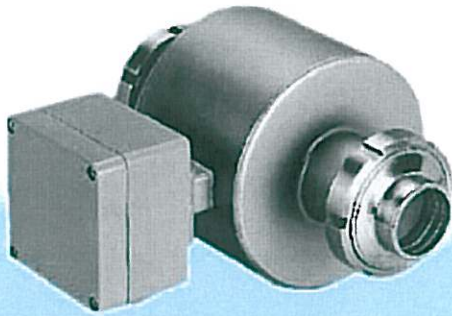

Fig. 3/37 SITRANS F M flow sensors 711/D, 911/D

3

## Application

The SITRANS F M electromagnetic flow sensors 711/D and 911/D are particularly suitable for use in the food industry. The constant magnetic field means that the sensors are suitable for average flow velocities up to 12 m/s (39.4 ft/s) and a minimum conductivity of 3  $\mu\text{S}/\text{cm}$ .

The complete flowmeter consists of a flow sensor and an associated SITRANS F M transmitter. These operate according to Faraday's law of induction where an electric voltage is induced in a conductor moving through a magnetic field.

Main applications of the SITRANS F M electromagnetic flow sensors 711/D and 911/D are:

- Breweries
- Dairies
- Juice and agricultural production plants

## Special features of the SITRANS F M flow sensors 711/D, 911/D

- The design complies with the hygiene regulations required in these applications
- A 3A-Sanitary Standard approval (American food approval) has been assigned with No. 386
- Fitting made completely of stainless steel 1.4103/430F, junction box of anodized aluminum
- Metering tube lining made of PTFE, connections and electrodes of materials appropriate to food
- Various connections available including standard flange EN1092-1, Triclamp and screwed gland to DIN 11 851
- Input amplifier with integral data component (smartPLUG) for all calibration values and customized settings
- Pulsed alternating field sensor for media with a high solids content and pulsed flows

## Technical data

<b>Application</b>	See left
<b>Mode of operation</b>	
• SITRANS F M 711/D	For pulsed constant field
• SITRANS F M 911/D	For pulsed alternating field
<b>Rated operating conditions</b>	
<b>Reference conditions</b>	<ul style="list-style-type: none"> <li>• Clean water without gases or solids &gt; 200 <math>\mu\text{S}/\text{cm}</math></li> <li>• Flow profile with symmetrical rotation in pipeline</li> <li>• Calibration with associated transmitter</li> </ul>
Process temperature	25 °C $\pm$ 5 °C (77.0 °F $\pm$ 9 °F)
Ambient temperature	25 °C $\pm$ 5 °C (77.0 °F $\pm$ 9 °F)
Warming-up time	30 min
Installation conditions	Inlet pipe section > 10 x DN, outlet pipe section > 5 x DN; installed perpendicular to flow axis
<b>Ambient conditions</b>	
Temperature limits	Max. 150 °C (302 °F)
Pressure	Max. 10 bar (145 psi)
Degree of protection	IP 65/NEMA4 to IP 68/NEMA6 (IP 68/NEMA6 with fixed cable)
Measuring tolerance including transmitter at reference conditions	The error limit applies to the flow velocity at the mounting location, with retention of the installation guidelines and the measuring conditions
Minimum conductivity	
• 711/D	> 3 $\mu\text{S}/\text{cm}$
• 911/D	> 0.008 $\mu\text{S}/\text{cm}$
<b>Design</b>	
Version	<ul style="list-style-type: none"> <li>• Fully-welded stainless steel fitting</li> <li>• Always remote design</li> </ul>
Weight	See table on page 3/37
Connection versions	<ul style="list-style-type: none"> <li>• Flange version EN 1092-1</li> <li>• Flange version ANSI B16.5 150 RF</li> <li>• Screwed glands to DIN 11 851</li> </ul>
Sensor materials	
• Sensor body	Stainless steel 1.4103
• Electrodes	Standard mat. No. 1.4571/316 TI, optionally Hastelloy C4/2.4610
• Electrode gaskets	None, since self-sealing of lining
• Metering tube lining	PTFE
<b>Certificates and approvals</b>	3-A Sanitary Standard with No. 386 (American food approval)

#### Notes on pressure equipment directive

The devices are designed for liquids of danger group "Gases of fluid group 1". The categories differ according to the version, and are listed in the adjacent table.

The minimum temperature is defined at -10°C (14°F) for the flange materials C22.8 (1.0460) and ST52-5 (1.0570).  
The minimum temperature is defined at -20°C (-4°F) for the flange material 1.4571/316 TI.

#### Classification acc. to pressure equip. directive (DRGL 97/23/EC)

Order No. 7ME551	Permissible media	Category
3-0xAxx-xxxx	Gases of fluid group 1	Article 3.3
4-0xAxx-xxxx	Gases of fluid group 1	Article 3.3
3-0xCxx-xxxx	Gases of fluid group 1	Article 3.3
4-0xCxx-xxxx	Gases of fluid group 1	Article 3.3
3-0xDxx-xxxx	Gases of fluid group 1	I
4-0xDxx-xxxx	Gases of fluid group 1	II
3-0xExx-xxxx	Gases of fluid group 1	I
4-0xExx-xxxx	Gases of fluid group 1	II

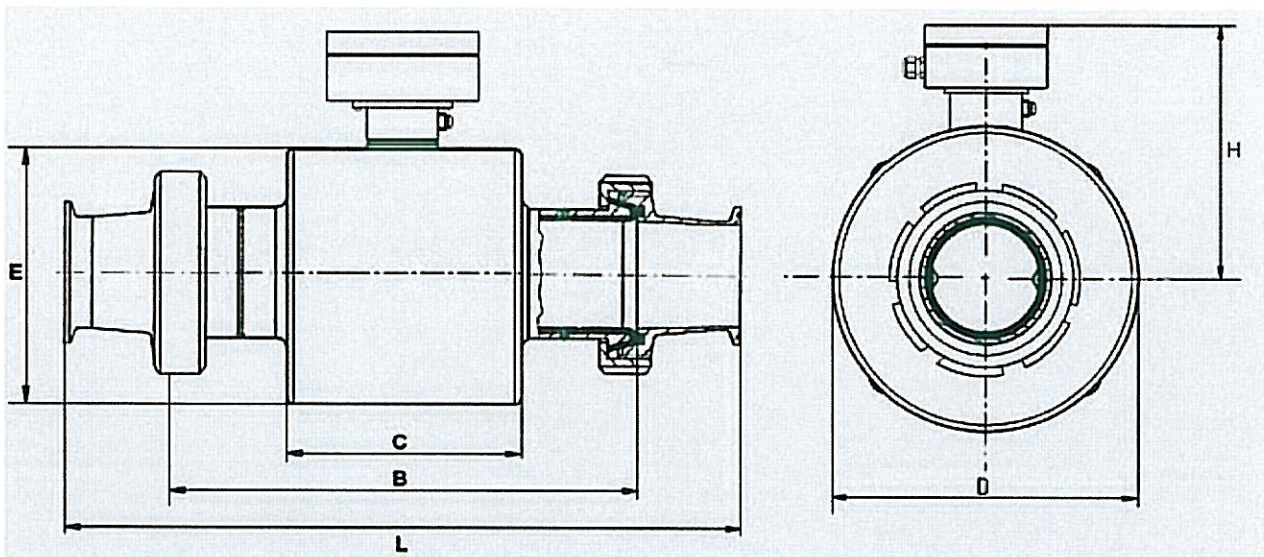

Fig. 3/38 Dimensions of SITRANS F M 711/D, 911/D in mm (inches)

Triclamp	Connections			Dimensions in mm (inches)								Weight			
	Screwed glands to DIN 11 851	Flange to EN 1092	Flange to ANSI B16.5 RF 150	L	B	C	H	E	kg	(lb)					
(1")	25	DN 25	(1")	350	(13.78)	270	(10.63)	170	(6.69)	202	(7.95)	136	(5.35)	9.5	(20.94)
-	32	DN 32	(1¼")	360	(14.17)	280	(11.02)	170	(6.69)	215	(8.46)	167	(6.57)	12.0	(26.46)
(1½")	40	DN 40	(1½")	380	(14.96)	280	(11.02)	170	(6.69)	215	(8.46)	167	(6.57)	13.0	(28.66)
(2")	50	DN 50	(2")	380	(14.96)	280	(11.02)	170	(6.69)	224	(8.82)	183	(7.20)	26.0	(57.32)
(2½")	65	DN 60	(2½")	420	(16.54)	330	(12.99)	170	(6.69)	252	(9.92)	248	(9.76)	27.0	(59.52)
(3")	80	DN 80	(3")	460	(18.11)	340	(13.39)	170	(6.69)	252	(9.92)	248	(9.76)	27.0	(59.52)
(4")	100	DN 100	(4")	460	(18.11)	340	(13.39)	170	(6.69)	274	(10.79)	273	(10.75)	29.0	(63.93)
-		DN 125	(5")	-	-	370	(14.57)	170	(6.69)	274	(10.79)	273	(10.75)	33.0	(72.75)
-		DN 150	(6")	-	-	370	(14.57)	170	(6.69)	274	(10.79)	273	(10.75)	39.0	(86.98)
-		DN 200	(8")	-	-	410	(16.14)	240	(9.45)	290	(11.42)	303	(11.93)	68.0	(149.91)
-		DN 250	(10")	-	-	470	(18.50)	240	(9.45)	290	(11.42)	303	(11.93)	80.0	(176.37)
-		DN 300	(12")	-	-	500	(19.68)	240	(9.45)	325	(12.80)	338	(13.31)	90.0	(198.42)

