



RE 250 Variable Area Flowmeter

# Operating instructions

All rights reserved. It is prohibited to reproduce this documentation, or any part thereof, without the prior written authorisation of MECON Flow Control Systems GmbH.

Subject to change without notice.

Copyright 2011 by  
MECON Flow Control Systems GmbH - Röntgenstraße 105 - 50169 Kerpen

# Contents

<b>1 Safety instructions</b>	<b>5</b>
1.1 Intended use	5
1.2 Certifications	6
1.3 Safety instructions from the manufacturer	6
1.3.1 Disclaimer	6
1.3.2 Product liability and warranty	6
1.3.3 General information	7
1.4 Safety instructions for the operator	7
<b>2 Device description</b>	<b>8</b>
2.1 Scope of delivery	8
2.2 Device versions	8
2.2.1 Display unit made of aluminium	8
2.2.2 Display unit made of stainless steel	9
2.2.3 Heating sheath	9
2.2.4 Float damping	9
2.3 Nameplate	10
2.4 Description code	11
2.4.1 Individual part for versions CF-S and EF-H	11
2.4.2 Individual part for version FF-P	13
2.4.3 Common part for all versions	14
<b>3 Installation</b>	<b>15</b>
3.1 Notes on installation	15
3.2 Storage	15
3.3 Installation conditions	15
3.3.1 Tightening torques	17
3.3.2 Magnetic filters	17
<b>4 Electrical connections</b>	<b>18</b>
4.1 Safety instructions	18
4.2 Electrical connections	18
4.2.1 Limit switches	18
4.2.2 Current output (MEM)	19
4.2.3 Current output with digital outputs (MEM)	20
4.3 Protection category	21

<b>5 Start-up</b>	<b>22</b>
5.1 Standard device	22
5.2 Device with current output	22
5.3 Device with limit switches	23
<b>6 Service</b>	<b>24</b>
6.1 Maintenance	24
6.2 Replacing float damping	24
6.3 Replacing floats	25
6.4 Returning the device to the manufacturer	26
6.5 Disposal	26
<b>7 Technical data</b>	<b>27</b>
7.1 Operating principle	27
7.2 Classification	27
7.3 Technical data	28
7.4 Pressure limits vs. temperature	30
7.5 Dimensions and weights	31

# 1 Safety instructions

## 1.1 Intended use

The series *RE250* of flowmeters with a standard length of 250 mm (9.84 inch) and a completely metal design is suitable for measuring different liquids and gases in closed piping.

The robust design enables the operation in rough conditions also. Different types of flanges, liners and float materials satisfy the requirements of the pharmaceutical and chemical Industries.

### **The devices are particularly suitable for the measurement of:**

- Water
- Fluids
- Corrosion protection agents
- Lubricants
- Saturated and superheated steam
- Food and beverages
- Industrial gases



#### *Warning!*

*Solely the operator of these measuring devices is responsible for suitability, intended use and corrosion resistance of the used materials. It must be particularly ensured that the materials selected for the wetted parts of the flowmeter are suitable for the used process media.*

*The manufacturer is not liable for any damage resulting from improper or unintended use of these devices.*

No external loads may act upon the meter. The flowmeters are primarily designed for static applications.



#### *Caution!*

#### **Hot surfaces resulting from hot process media.**

*Danger of burns resulting from surface temperatures above 70 °C.*

- *Take appropriate protective measures, for example contact protection.*
- *The design of the contact protection must ensure here that the maximum permissible ambient temperature of the meter is not exceeded.*



#### *Caution!*

***For devices used in hazardous areas, additional safety notes apply; please refer to the Ex documentation!***

The flowmeter may only be operated within the pressure and voltage limits specified on the name plate.

Before replacing the flowmeters, check that the unit is free of hazardous media and pressures.

## 1.2 Certifications

### CE marking



**The manufacturer certifies for the device RE 250 the fulfilment of all statutory requirements of the following EC directives by applying the CE marking:**

- Pressure equipment directive 97/23/EC
- Low voltage directive 2006/95/EC \*
- EMC-directive 89/336/EEC
- NAMUR recommendation NE21 \*
- ATEX directive 94/9/EC \*\*

(\* Devices with electrical installations)      (\*\* Devices for use in hazardous areas)

## 1.3 Safety instructions from the manufacturer

### 1.3.1 Disclaimer

The manufacturer will not be liable for any damage using its product, including, but not limited to direct, indirect, incidental, punitive and consequential damages.

Any product purchased from the manufacturer is warranted in accordance with the relevant product documentation and our Terms and Conditions of Sale.

The manufacturer reserves the right to revise the content of its documents, including this disclaimer, without prior notification, and will not be liable in any way for possible consequences of such changes.

### 1.3.2 Product liability and warranty

Mecon GmbH can assume no guarantee for repair work carried out by the customer without prior notification and consultation. In case of complaint, the rejected parts must be returned to us, if no other arrangement has been made.

### 1.3.3 General information

This manual is intended for correct installation as well as operation and maintenance of the devices. Read the instructions carefully before installing the device and put it into operation.

Specially designed or customised models and specialised applications are not included in this manual.

## 1.4 Safety instructions for the operator



*Warning!*

***Hot surfaces resulting from hot process media.***

*Danger of burns resulting from surface temperatures above 70 °C.*

- *Take appropriate protective measures, for example contact protection.*
- *The design of the contact protection must ensure here that the maximum permissible ambient temperature of the meter is not exceeded.*



*Caution!*

***For devices used in hazardous areas, additional safety notes apply; please refer to the Ex documentation!***

## 2 Device description

### 2.1 Scope of delivery

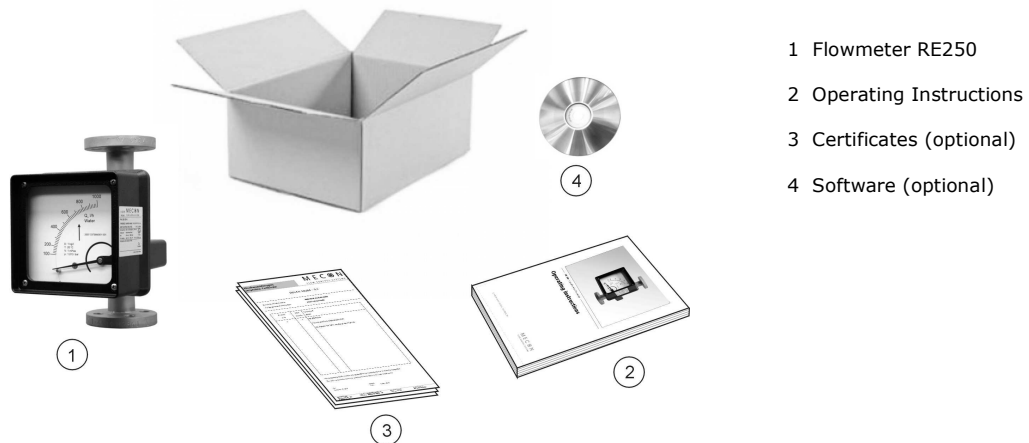

**Fig 2.1** Scope of delivery



**Information!**

Please check the delivery for completeness using the packing list.

### 2.2 Device versions

#### 2.2.1 Display unit made of aluminium

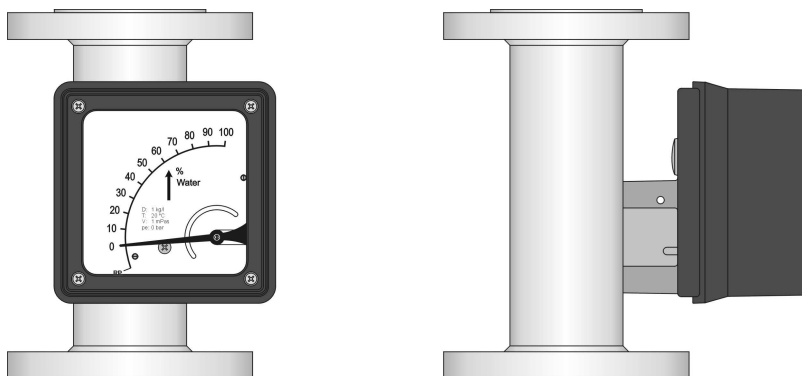

**Fig. 2.2** Standard device with display unit made of aluminium

The measured value is indicated directly on the scale. The equipment can be supplied with accessory electrical components and touch-sensitive switches for process monitoring and control.

### 2.2.2 Display unit made of stainless steel

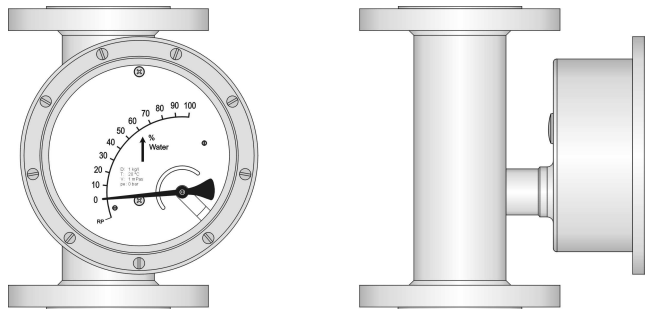

**Fig. 2.3** Standard device with display unit made of stainless steel

For applications with the requirements of higher protection category or corrosion resistance the devices are available with a display unit made of stainless steel.

### 2.2.3 Heating sheath

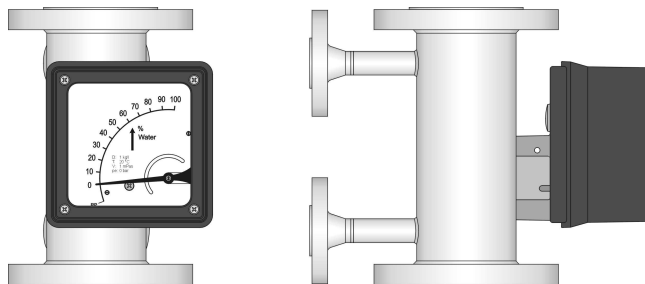

**Fig. 2.4** Device with heating sheath

For measuring points where a temperature drop is unacceptable the devices are available with an external heating sheath.

### 2.2.4 Float damping

A float damping is recommended

- Generally for measuring gases
- Vibrations for the piping cannot be avoided

It is also strongly recommended in the case of

- applications where air bubbles in the medium cannot be avoided
- predominating shock pressure in the piping, e.g. due to rapid throttling or shut-off
- turbulences, pulsations, etc. which could lead to vibrations to the flowmeter
- rapid pressure build-up in the piping

## 2.3 Nameplate



*Important!*

**Please refer to the device nameplate to ensure that the device is built according to your order.**

*Check particularly for the correct supply voltage.*

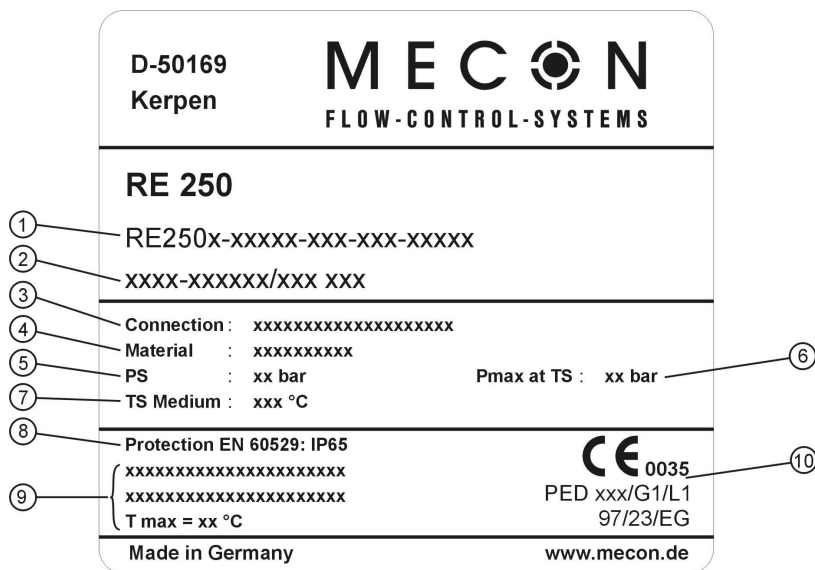

①	Code number	Device specific code number
②	Year / Serial number	Device specific serial number and the year it was built
③	Connection	Connection type of the device
④	Material	Material of the wetted parts
⑤	PS	Maximum pressure of the medium
⑥	Pmax at TS	Maximum pressure of the medium at temperature TS
⑦	TS Medium	Maximum temperature of the medium
⑧	Protection	Protection class for the housing of display
⑨	MEM specification	Electrical specifications of the output / transducer (MEM)
⑩	Category	Category acc. to Pressure Equipment directive (PED)

**Fig. 2.5** Nameplate of the RE250

## 2.4 Description code

### 2.4.1 Individual part for versions CF-S (stainless steel) and EF-H (Hastelloy®)

The description code consists of the following elements:

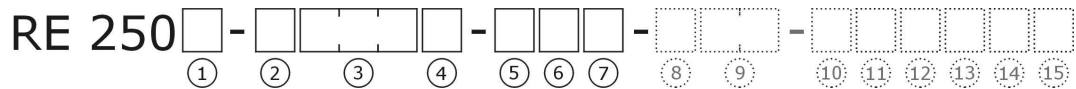

#### ① Flow tube

<b>A</b>	Nominal size flow tube DN 15
<b>B</b>	Nominal size flow tube DN 25
<b>C</b>	Nominal size flow tube DN 40
<b>D</b>	Nominal size flow tube DN 50
<b>E</b>	Nominal size flow tube DN 80
<b>F</b>	Nominal size flow tube DN 100

#### ② Version

<b>1</b>	CF-S	wetted parts: stainless steel
<b>2</b>	EF-H	wetted parts: Hastelloy®

#### ③ Process connections

##### Flanges

		EN1092-1	ANSI B16.5	Flow tube EN						Flow tube ANSI						
				A	B	C	D	E	F	A	B	C	D	E	F	
Nominal size	<b>Axx</b>	DN 15	1/2"	●	●						●	○				
	<b>Bxx</b>	DN 20	3/4"	●	●	○					●	●				
	<b>Cxx</b>	DN 25	1"	●	●	●					●	●	○			
	<b>Dxx</b>	DN 32	1 1/4"	●	●	●	○				●	●	●			
	<b>Exx</b>	DN 40	1 1/2"	●	●	●	○				●	●	●	○		
	<b>Fxx</b>	DN 50	2"	●	●	●	●				●	●	●	●		
	<b>Gxx</b>	DN 65	2 1/2"		●	●	●	○				●	●	●	○	
	<b>Hxx</b>	DN 80	3"			●	●	●	○				●	●	●	
	<b>Jxx</b>	DN 100	4"				●	●	●					●	●	●
	<b>Kxx</b>	DN 125	5"					●	●						●	●
<b>Lxx</b>	DN 150	6"						●	●					●	●	

● = available    ○ = reduced scale raised face

<b>xBx</b>	PN 16	(EN 1092-1)	DN65 - DN150	
<b>xDx</b>	PN 40	(EN 1092-1)	DN15 - DN150	
<b>xEx</b>	PN 63	(EN 1092-1)	DN50 - DN150	
<b>xFx</b>	PN 100	(EN 1092-1)	DN15 - DN150	
<b>xGx</b>	PN 160	(EN 1092-1)	DN15 - DN150 (DN 20 and DN 32 not available)	
<b>xHx</b>	150 lbs	(ASME B16.5)	1/2" - 6"	
<b>xJx</b>	300 lbs	(ASME B16.5)	1/2" - 6"	
<b>xKx</b>	600 lbs	(ASME B16.5)	1/2" - 6"	

<b>xxA</b>	B1	(EN 1092-1)	PN 16 / PN40	
<b>xxB</b>	B2	(EN 1092-1)	PN 63 / DN100	
<b>xxC</b>	Form D	(EN 1092-1)	DN15 - DN150	
<b>xxD</b>	Form C	(EN 1092-1)	DN15 - DN150	
<b>xxG</b>	Form RF	(ASME B16.5)	1/2" - 6"	
<b>xxH</b>	Form FF	(ASME B16.5)	1/2" - 6"	
<b>xxJ</b>	Form RTJ	(ASME B16.5)	1" - 6"	

③ Process connections (continued)

**Threaded connection**

<b>Txx</b>	Female thread													
<b>xTx</b>	DIN ISO 228													
<b>xNx</b>	NPT ANSI B 1.20.1													
	<b>DIN ISO 228</b>	<b>ANSI B1.20.1</b>	<b>Flow tube EN</b>						<b>Flow tube ANSI</b>					
			<b>A</b>	<b>B</b>	<b>C</b>	<b>D</b>	<b>E</b>	<b>F</b>	<b>A</b>	<b>B</b>	<b>C</b>	<b>D</b>	<b>E</b>	<b>F</b>
<b>xx1</b>	G 1/2	NPT 1/2"	●	●					●	●				
<b>xx2</b>	G 3/4	NPT 3/4"	●	●					●	●				
<b>xx3</b>	G 1	NPT 1"	●	●					●	●				

● = available

④ Heating sheath

<b>0</b>	Without
<b>1</b>	With flange connection DN15 DIN 2501 PN40 in stainless steel
<b>2</b>	With flange connection DN25 DIN 2501 PN40 in stainless steel
<b>3</b>	With flange connection 1/2" ANSIB16.5 150RF in stainless steel
<b>4</b>	With flange connection 1" ANSIB16.5 150RF in stainless steel

⑤ Maximum range values / Measuring ranges

	Fluids		Gases		Ratio	Viscosity limits* [mPa·s]	Pressure drop [mbar]					
	[l/h]	[USgpm]	[m³/h]	[scfm]			A	B	C	D	E	F
<b>1</b>	5	0,022	0,15	0,088	1:10	≤ 1,0	40	◇	◇	◇	◇	◇
<b>2</b>	10	0,044	0,30	0,177	1:10	≤ 1,0	44	◇	◇	◇	◇	◇
<b>3</b>	16	0,07	0,48	0,283	1:10	≤ 1,0	40	◇	◇	◇	◇	◇
<b>4</b>	25	0,11	0,75	0,441	1:10	≤ 1,0	40	◇	◇	◇	◇	◇
<b>5</b>	40	0,18	1,3	0,765	1:10	≤ 1,0	40	◇	◇	◇	◇	◇
<b>A</b>	50	0,22	1,5	0,883	1:10	≤ 1,0	40	◇	◇	◇	◇	◇
<b>B</b>	70	0,31	2,1	1,24	1:10	≤ 1,0	40	◇	◇	◇	◇	◇
<b>C</b>	100	0,44	3,0	1,77	1:10	≤ 1,0	60	◇	◇	◇	◇	◇
<b>D</b>	160	0,70	4,6	2,71	1:10	1...3	60	◇	◇	◇	◇	◇
<b>E</b>	250	1,10	7,0	4,12	1:10	1...3	60	◇	◇	◇	◇	◇
<b>F</b>	400	1,76	11	6,47	1:10	1...3	70	◇	◇	◇	◇	◇
<b>G</b>	600	2,64	17	10,00	1:10	1...5	80	◇	◇	◇	◇	◇
<b>H</b>	1000	4,40	30	17,66	1:10	1...5	◇	60	◇	◇	◇	◇
<b>J</b>	1600	7,0	46	27,07	1:10	1...5	◇	70	◇	◇	◇	◇
<b>K</b>	2500	11,0	70	41,20	1:10	1...5	◇	100	50	◇	◇	◇
<b>L</b>	4000	17,6	110	64,74	1:10	1...8	◇	240	120	80	◇	◇
<b>M</b>	6000	26,4	170	100,0	1:10	1...8	◇	◇	180	90	◇	◇
<b>N</b>	10.000	44,0	290	170,7	1:10	1...8	◇	◇	◇	110	◇	◇
<b>P</b>	16.000	70,0	460	270,7	1:10	1...10	◇	◇	◇	230	70	◇
<b>Q</b>	20.000	88,0	550	323,7	1:10	1...10	◇	◇	◇	230	70	◇
<b>R</b>	25.000	110,0	700	412,0	1:10	1...10	◇	◇	◇	500	100	◇
<b>S</b>	40.000	176,0	1.100	647,4	1:10	1...15	◇	◇	◇	◇	350	120
<b>T</b>	50.000	220,0	1.350	794,6	1:10	1...15	◇	◇	◇	◇	350	120
<b>U</b>	60.000	264,0	1.700	1.000	1:10	1...25	◇	◇	◇	◇	◇	360
<b>V</b>	80.000	352,0	2.400	1.413	1:10	1...25	◇	◇	◇	◇	◇	600
<b>W</b>	100.000	440,0	3.000	1.766	1:10	1...25	◇	◇	◇	◇	◇	600

\* devices for media with higher viscosity on request

◇ = not available

⑥ Measured medium

<b>1</b>	Water ( $\eta = 1 \text{ mPa}\cdot\text{s}$ , $\rho = 1 \text{ kg/l}$ )
<b>2</b>	Air ( $T = 0 \text{ }^\circ\text{C}$ , $p_e = 0 \text{ bar}$ , $\eta = 0.0181 \text{ mPa}\cdot\text{s}$ , $\rho = 1,293 \text{ kg/m}^3$ )
<b>3</b>	Specify in plain text

⑦ Float damping

<b>0</b>	Without float damping
<b>1</b>	With float damping



### 2.4.3 Description code – common part for all versions

The description code consists of the following elements:

RE 250   -         -         -     -            

1  
2  
3  
4  
5  
6  
7  
8  
9  
10  
11  
12  
13  
14  
15

#### ⑧ Display unit / Process temperature

<b>0</b>	Standard (aluminium)	- up to 200 °C for local display / 150 °C for electric output)
<b>1</b>	Standard (aluminium)	- with displaced display (extension made of stainless steel)
<b>2</b>	Stainless steel IP66	- up to 150 °C
<b>3</b>	Stainless steel IP66	- with displaced display

#### ⑨ Outputs

<b>AA</b>	With local display
<b>CJ</b>	With local display, 1 inductive contact SJ 3,5N
<b>CL</b>	With local display, 2 inductive contacts SJ 3,5N
<b>EA</b>	With local display, electric remote sensor 4-20 mA
<b>EL</b>	With local display, electric remote sensor 4-20 mA, 2 inductive contacts SJ 3,5N
<b>EJ</b>	With local display, electric remote sensor 4-20 mA, 1 inductive contact, 1 pulse output
<b>FA</b>	With HART protocol, 4-20mA
<b>FL</b>	With HART protocol, 4-20mA, 2 inductive contacts SJ 3,5N
<b>FJ</b>	With HART protocol, 1 inductive contact, 1 pulse output
<b>PA</b>	With PROFIBUS PA interface

#### ⑩ Certification of accuracy

<b>0</b>	Without calibration certificate
<b>1</b>	Certification of accuracy class (4.2.1)
<b>2</b>	With calibration report (5 calibration points)
<b>3</b>	With calibration report (10 calibration points)

#### ⑪ Leak / pressure test

<b>0</b>	Without leak/pressure test
<b>1</b>	Pressure test acc. to EN 10204 with inspection certificate 3.1
<b>2</b>	Leak test acc. to EN 10204 with inspection certificate 3.1
<b>3</b>	Pressure test + leak test (acc. to EN 10204 with inspection certificates 3.1)

#### ⑫ Material certificates

<b>A</b>	Without certificate
<b>B</b>	Certificate of Compliance with the Order 2.1 according to DIN EN 10 204
<b>C</b>	Inspection certificate 3.1 with material analysis (DIN EN 10204:2004) for wetted parts

#### ⑬ Cleaning to factory standard

<b>A</b>	Without cleaning
<b>B</b>	Cleaning class VA – with marking: free from oil and grease
<b>C</b>	Cleaning class VA – with marking: free from oil, grease and silicone

#### ⑭ Approvals

<b>0</b>	Without
<b>1</b>	Explosion protection – mechanical approval ATEX BVS06ATEXII2GDc
<b>2</b>	Explosion protection – mechanical and electrical (MEM/MEM-PPA) approval ATEXII2GExiaIICT6

#### ⑮ Marking

<b>0</b>	Without marking
<b>1</b>	Cardboard plate with a cable tie
<b>2</b>	Stainless steel plate (dimensions 40 x 20mm)
<b>3</b>	Cardboard plate with cable tie + stainless steel plate (dimensions 40 x 20 mm)

## 3 Installation

### 3.1 Notes on installation



*Information!*

All instruments are carefully checked for functional capability before distribution. On receipt of the device please carry out a visual inspection of the outer packing for damage or improper handling.

Please contact the carrier and your responsible sales field service if you should discover any defects. In such cases a description of the defect, the type and the serial number of the device is needed.



*Information!*

Unpack the equipment with care to prevent damage.



*Information!*

All instruments are carefully checked for order conformity. Please check the delivery for completeness using the packing list. Please examine the flowmeter nameplate to verify that the device was built according to your order. Particularly check devices with electrical components for the correct supply voltage.

### 3.2 Storage

- Store the device in a dry and dust-free place.
- Keep away from direct sun and heat.
- Avoid external load to the device.
- The storage temperature range for standard devices with electrical components is about -40 ... +70 °C / -40 ... +158 °F.

### 3.3 Installation conditions

**Below the essential points concerning installation are described and have to be observed:**

- Remove the transport securing device from the fitting.
- Verify prior to installation that the float slides smoothly in the fitting without canting or deadlocking. The pointer must smoothly follow the float movement.
- Verify that accessories such as spring stop, gas/fluid damping are still correctly fixed in the fitting.

- In the zero position (no flow) the pointer must be at the marked reference point (first line on the scale). When moving the float manually to the end position, the pointer must be above the final value of the scale.
- The flowmeter must be installed vertically – flow direction from bottom to top. For installation recommendations refer to guideline VDI/VDE 3513 Part 3.
- The installation in the piping must be tension-free – therefore the piping must be positioned parallel and aligned to each other.
- Avoid a corrosive atmosphere – provide a ventilation where necessary.
- Ensure a sufficient distance of at least 200 mm to magnet-influencing parts like e.g. solenoid valves and ferromagnetic components e.g. steel brackets.
- Observe a lateral distance of at least 300 mm between two next to one another mounted devices. The distance can be reduced by mounting the devices staggered by the length of one device. In case of doubt the influence can be tested by moving the instrument up and down ca. 200 mm at a selected distance and check whether the position of the pointer in the display changes.
- Specify the installation zone regarding a reliable reading of the displayed values and adequate space for servicing.
- An inlet run upstream and an outlet run downstream the device is not necessary in the case of linear media flow profile. In the case of highly asymmetric flow profiles, however, additional measures (e.g. inlet tracks, flow rectifiers) with a length of at least 250 mm could be appropriate to ensure the measuring accuracy.
- Avoid the installation of unilaterally constricting fittings upstream of the device.
- Ensure that the piping has been mounted securely to avoid vibration or oscillation of the devices.
- The nominal width of the flowmeter and the connected piping must be identically.
- Use connectors suitable for the particular device version (dimension, pressure stage).
- Ensure that the clearance between the flanges of the piping corresponds to the device dimension additionally two gaskets.
- Before connecting the device, blow or flush out the pipes leading to the device.
- The surface roughness of the flange sealing areas must be appropriate for the used gaskets.
- The used gaskets and bolts of the prescribed dimensions must be appropriate for the operating pressure, the temperature and the media.
- **Do not use carbon steel mounting brackets for the device!**

Additionally for **devices with PTFE liner:**

- Use gaskets which are conform to the inner and outer dimensions with the raised face of the flowmeter.
- Tighten the screws crosswise to ensure the tightness of the process connections. For the tightening torques please refer to chapter "3.3.1 Tightening torques".

- If the instrument is absolutely calibrated for a pressure exceeding 1.013 bar the valve is usually installed at the rear of the flowmeter, at 1.013 bar absolute (free emanation) in front of the instrument.

#### Particularities for measuring gas flow:

- Valves have to be installed downstream of the device if  $p_{abs} > 1.013$  bar and upstream of the device if  $p_{abs} = 1.013$  bar (free outflow) usually.
- Install a throttle just downstream of the device to prevent compression oscillation during measurement.
- Ensure by means of design features that the operating pressure for the flowmeter corresponds to the reference pressure of the calibration to avoid erroneous measurements.

### 3.3.1 Tightening torques

The flange bolts for devices with PTFE liner may be tightened with the following torques (acc. guideline VDI/VDE 3513):

Process connection		max. torque	
EN1092-1	ANSI B16.5	Nm	ft·lbf
15	½"	14	10
25	1"	14	10
40	1 ½"	25	18
50	2"	25	18
80	3"	35	25
100	4"	42	30

**Tab 3.1** Tightening torques for devices with PTFE liner

### 3.3.2 Magnetic filters

To prevent a malfunction of the flowmeter caused by a medium which contains ferromagnetic substances such as weld beads a magnetic filter should be mounted in flow direction upstream of the measuring instrument.

This kind of filter is also recommended if such particles cannot be avoided in standard operation.





### 4.2.3 Current output with digital outputs (MEM)

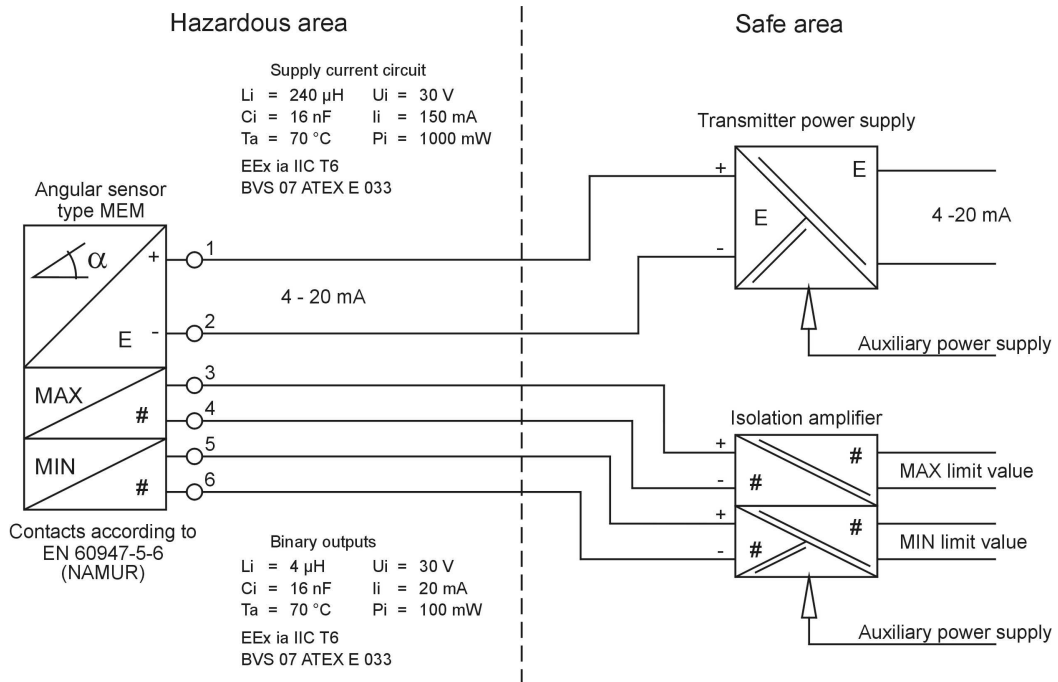

**Fig 4.8** Connection diagram for transducer MEM with 2 limit switches

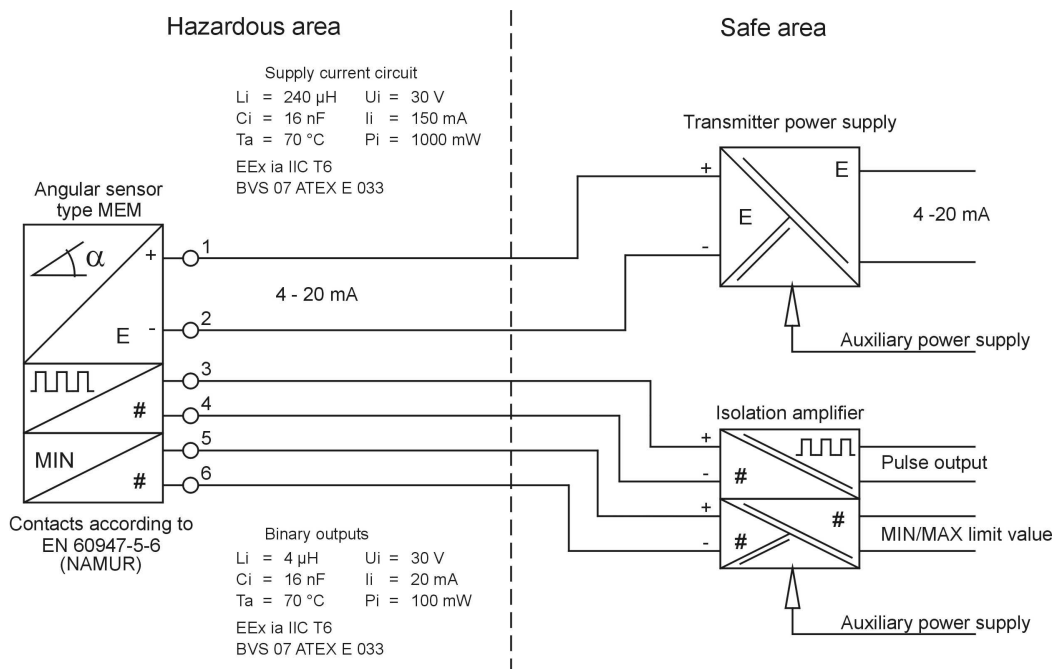

**Fig 4.9** Connection diagram for transducer MEM with limit switch and pulse output

### 4.3 Protection class

The realised protection class of the display unit made of aluminium is class IP65. The version made of stainless steel will meet all requirements of protection class IP66.



**Caution!**

**After installation and any maintenance work on the device, the operator has to check and ensure the specified protection class again.**

Therefore pay regard to the following issues:

- Mounting screws of the display unit must be tightened.
- All gaskets (display unit and cable glands) have to be undamaged. Broken gaskets have to be replaced.
- The electrical cable glands must be free of any damage and tightened. Broken cable glands have to be replaced.
- Install the cables with a loop in front of the cable glands so that moisture does not get inside the display unit (refer to Fig. 4.5).

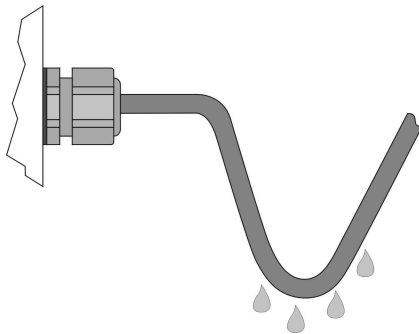

**Fig 4.10** Installing the cables in front of the cable glands (loop)

# 5 Start-up

## 5.1 Standard device

When starting up the device, the following points must be observed:

- Ensure that the actual operation conditions (pressure, temperature) do not exceed the limits which are given on the nameplate of the device
- Avoid float impacts!  
Therefore it is recommended to start up with a closed shut-off valve and open it slowly. Particularly the use of solenoid valves is not recommended.
- When measuring liquids, the pipes must be vent slowly to prevent shock pressure due to gas bubbles.
- When measuring gases, the pressure must be increased slowly in order to prevent high shock pressure.
- During the start-up of new systems, residual materials are conveyed in the medium and could adhere to the float. In this case we recommend cleaning the instrument after a relatively short period of operation.
- When operating the flowmeter at low flowrates, the device has to start-up with a high flowrate to allow the float to level out. This will ensure measurements within the specified accuracy class.

## 5.2 Device with current output (MEM)

The magneto-electrical measuring transducer (MEM) is completely factory-set when it is delivered to the customer.

After applying the supply voltage to the device, initially the current output will be about 3.5 mA to 4 mA for a few seconds. After that a current corresponding to the pointer deflection will flow.



*Important!*

*Due to the influence of the float magnet, the MEM transmitter will only output the correct current if the pointer position is caused by the float. Turning the pointer manually will cause incorrect values, but it's suitable for testing the unit.*

### 5.3 Device with limit switches

The limit switches can be set over the entire measuring range by varying the position the limit pointers.



**Important!**

Unless otherwise desired by the customer, the factory set value for the switching point is for version with one limit switch about **40% of URV** and for devices with two limit switches about **20% / 80% of URV**.

To set the limit switches at the desired position the following step have to be observed:

- Unloosen the two little fixing screws 2 before moving the pointer 1.
- Move the pointer to the desired position.
- Tighten the screws to fix the pointer.

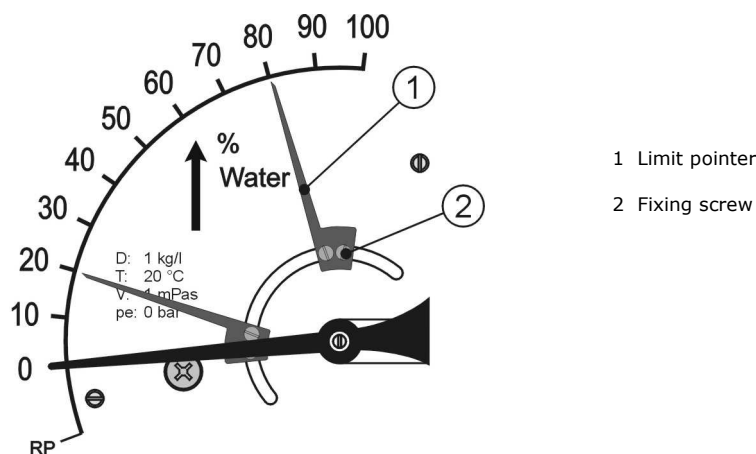

**Fig 5.1** Adjustment of the switching point (limit switch)



**Important!**

The applied limit switches SJ 3,5 N are normally closed contacts according to NAMUR recommendation NE21. The desired switching function of the limit switch has to be realized by the relay contact of the external isolation amplifier (changeover contact).

## 6 Service

### 6.1 Maintenance

The devices were built within the scope of low maintenance but periodically the flowmeters should be inspected for signs of corrosion, mechanical wear as well as damage to the fitting and the display unit.

We advice to carry out inspections at least once a year.

For a detailed inspection and cleaning the device must be removed from the piping.



**Caution!**

*Appropriate safety precautions have to be taken when removing the device. Always use new gaskets when reinstalling the device in the piping.*

### 6.2 Replacing float damping

*Devices with measuring ring*

For devices with standard measuring ranges starting from 5-50 l/h (gases: 0.15 – 1.5 m<sup>3</sup>/h) the float damping can be replaced by the customer:

- Remove the device from the piping.
- Fix the device, ensuring that the fitting will not be damaged.
- The damping cylinder ⑥ is fixed by retaining clamps ⑤. Bend up these two clamps carefully using a suitable tool.
- Move the damping cylinder a little bit to the bottom end of the fitting, make a quarter turn and take the cylinder out of the fitting.
- Insert the new damping cylinder into the fitting from the top, slide it over the damping part of the float and arrange it into the retaining clamps.
- Fix the cylinder by bending the retaining clamps together.
- Fit the device back into the piping.

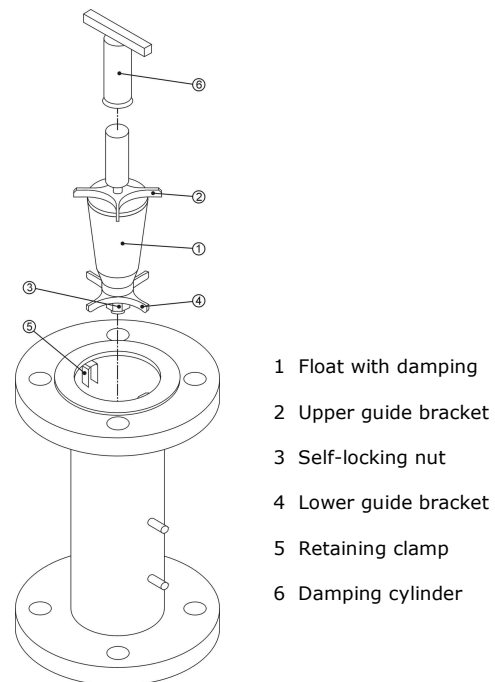

**Fig 6.1** Replacing float damping

## 6.3 Replacing floats

### *Devices with measuring ring*

For devices with standard measuring ranges starting from 5-50 l/h (gases: 0.15 – 1.5 m<sup>3</sup>/h) the replacement of the float can be provided by the customer:

- Remove the device from the piping.
- Fix the device ideally in a horizontal position, ensuring that the fitting will not be damaged.
- Prevent the float ① from torsion by fixing the upper guide bracket ② using a suitable tool.
- Remove the self-locking ③ nut which fix the lower guide bracket ④ and take the guide bracket out of the fitting.
- Take the float out of the measuring unit upwards.
- Insert the new float into the fitting from the top. While doing so put the bottom end of the float through the measuring ring carefully.
- Slip the lower guide bracket through the tread at the bottom end of the float and fix it with the self-locking nut.
- Fit the device back into the piping.

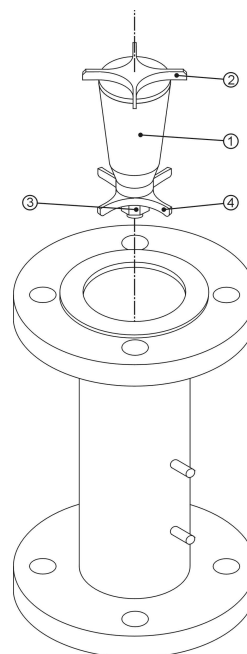

- 1 Float
- 2 Upper guide bracket
- 3 Self-locking nut
- 4 Lower guide bracket

**Fig 6.2** Replacing floats



### **Important!**

**Avoid damaging both float and measuring ring.**



### **Important!**

*After the replacement of the float a recalibration of the flowmeter is highly recommended, otherwise the measurement accuracy can't be ensured.*

### *Devices with cone*

- Replacing floats for devices with cone (standard measuring ranges up to 5-50 l/h (gases: 0.15 – 1.5 m<sup>3</sup>/h) cannot be provided by the customer. For this purpose the device has to be returned to the manufacturer. For details please refer to chapter "6.4 Returning the device to the manufacturer".

## 6.4 Returning the device to the manufacturer

This device has been carefully manufactured and tested. Should you nevertheless need to return a device to MECON GmbH please observe the following points:



**Caution!**

*According to the actual waste disposal directives, the owner/customer is responsible for the waste management of hazardous and toxic waste.*

*For reasons of environmental protection and safeguarding the health and safety of our personnel **all devices sent to MECON GmbH to be repaired must be free of toxic and hazardous substances. This also applies to cavities of the devices. If necessary the customer is kindly requested to neutralize or rinse the devices before returning to MECON.***

*The customer has to confirm this by filling in an appropriate form which is available for download on the MECON website:*

[www.mecon.de/en/declaration/contamination.pdf](http://www.mecon.de/en/declaration/contamination.pdf)



**Caution!**

*In the case of returning devices, despite these requirements, which contain hazardous and toxic substances, Mecon GmbH is entitled to dispose these substances at the cost of the customer without any further inquiries.*

## 6.5 Disposal



**Caution!**

*Disposal of the devices has to be carried out in accordance with relevant legislation in your country.*

# 7 Technical data

## 7.1 Operating principle

Like other devices of this series the variable area flowmeter *RE250* operates on the principle of flotation:

The measuring unit consists of a metal tube with a measuring ring in which a float can move up and down. The media is flowing upwards through the tube and raises the conical float. Here the annular gap enlarges until the equilibrium between the buoyancy force  $F_A$ , the drag force  $F_S$  and the weight of the float  $F_G$  has been reached. The adjusted height of the float is directly proportional to the flowrate. The movement of the float is transmitted via a magnet to a subsequent magnet in the display unit outside the measuring pipe.

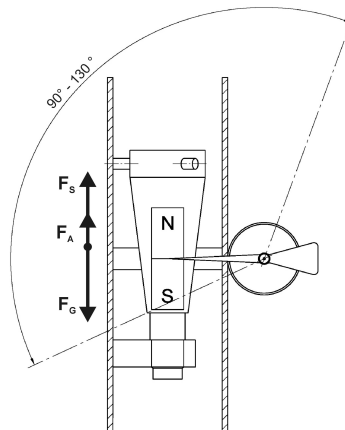

**Fig. 7.1** Operating principle of the RE250

## 7.2 Classification

Classification in accordance with the Pressure Equipment Directive (PED) 97/23/EC:

Process connection		Admissible media	Category
EN1092-1	ANSI B16.5		
DN 15	1/2"	Gases and fluids of fluid group 1	Art. 3.3
DN 20	3/4"	Gases and fluids of fluid group 1	Art. 3.3
DN 25	1"	Gases and fluids of fluid group 1	Art. 3.3
DN 32	1 1/4"	Gases and fluids of fluid group 1	III
DN 40	1 1/2"	Gases and fluids of fluid group 1	III
DN 50	2"	Gases and fluids of fluid group 1	III
DN 65	2 1/2"	Gases and fluids of fluid group 1	III
DN 80	3"	Gases and fluids of fluid group 1	III
DN 100	4"	Gases and fluids of fluid group 1	III
DN 125	5"	Gases and fluids of fluid group 1	III
DN 150	6"	Gases and fluids of fluid group 1	III

**Tab 7.1** Classification in accordance with PED 97/23/EC

## 7.3 Technical data

### General data

<i>Range of application</i>	Flow measurement of liquids and gases
<i>Measuring principle</i>	Flotation / Float measuring
<i>Orientation</i>	Vertical – flow direction from bottom to top

### Measuring accuracy\*

<i>Directive</i>	VDI / VDE 3513, sheet 2 (qG = 50%)
<i>Liquids</i>	G 1.6 (add. 0,2% <sup>**</sup> of URV for MEM/MEM-PPA)
<i>Gases</i>	G 2.5 (add. 0,2% <sup>**</sup> of URV for MEM/MEM-PPA)
<i>Reproducibility</i>	0,5% of URV (add. 0,1% of URV for MEM/MEM-PPA)

\* A variation of the operating temperature to the considered temperature for the calibration process, will lead to a corresponding inherent error

\*\* For ambient temperatures < -20°C the measuring error will increase

### Materials

		<b>Type CF-S</b>	<b>Type EF-H</b>	<b>Type FF-P</b>
<i>Wetted parts</i>		<b>Stainless steel</b>	<b>Hastelloy®</b>	<b>PTFE</b>
<i>Flange</i>	<= DN25 (1")	Stainless steel	Hastelloy®	Stainless steel
	> DN25 (1")		Hastelloy® stainless	
<i>Fitting</i>	<= DN25 (1")	Stainless steel	Hastelloy®	Stainless steel with PTFE liner
	> DN25 (1")		Hastelloy® stainless	
<i>Float + Guide bracket</i>		Stainless steel	Hastelloy®	PTFE
<i>Display unit</i>		Aluminium (optional stainless steel) with safety glass pane		

### Operating conditions –all devices

<b>Temperature</b>				
		<b>Type CF-S</b>	<b>Type EF-H</b>	<b>Type FF-P</b>
<i>Max. Medium temp. TS</i>		-20 °C ...+200 °C (opt. -80 °C ...+300 °C)		-20 °C ...+125 °C
<b>Pressure (refer to chapter 7.4)</b>				
		<b>Type CF-S</b>	<b>Type EF-H</b>	<b>Type FF-P</b>
<i>Max. Medium pressure PS</i>	DN 15 – DN 150:	PN 160 (optional up to 400 bar)		PN 16
	½" – 6":	580 psi (optional up to 5800 psi)		232 psi
<i>Min. operating pressure</i>		> 2 x pressure loss (see measuring ranges)		
<i>Climate classification</i>		Weatherproof and/or non heated locations Class C in accordance with DIN IEC 654 Section 1		
<b>Protection class (DIN EN 60529)</b>				
<i>Display unit</i>		made of aluminium: IP65 made of stainless steel: IP66		

## Temperatures

Device version	Ambient temperature*		Storage temperature	
	[°C]	[°F]	[°C]	[°F]
without electrical components	-40 ...+80	-40 ...+176	-40 ...+80	-40 ...+176
with limit switch(es)	-40 ...+65	-40 ...+149	-40 ...+65	-40 ...+149
with 4...20 mA output	-40 ...+70	-40 ...+158	-40 ...+70	-40 ...+158

\* IMPORTANT!



For applications in hazardous areas it is mandatory that the temperature class of the type examination certificate (protection type) will be regarded additionally.

For devices used in hazardous areas, additional safety notes apply; please refer to the Ex documentation!

### RE250 with limit switch(es)

Cable gland	M20 x1.5
Isolation (2 contacts)	Galvanic isolated
Terminal connection	2.5 mm <sup>2</sup>
Limit switch	SJ3.5-N-BU
Switching function	NAMUR, NC
Nominal voltage U <sub>o</sub>	8.2 V DC (R <sub>i</sub> approx. 1 kΩ)
Supply voltage	5 ... 25 V DC

### RE250 with current output 4 ... 20 mA

Cable gland	M20 x1.5
Terminal connection	2.5 mm <sup>2</sup>
Auxiliary supply voltage U <sub>B</sub>	14 V ... 30 V DC
Measuring signal	4 ... 20 mA = 0 ... 100% flow value in 2-wire technology
Power supply influence	< 0.1 %
Max. external load R <sub>B</sub>	680 Ω (30 V)     R <sub>B</sub> = (U <sub>B</sub> - 14V) / 22 mA
Temperature influence	< 10 μA / K

## 7.4 Pressure limits vs. temperature stainless steel

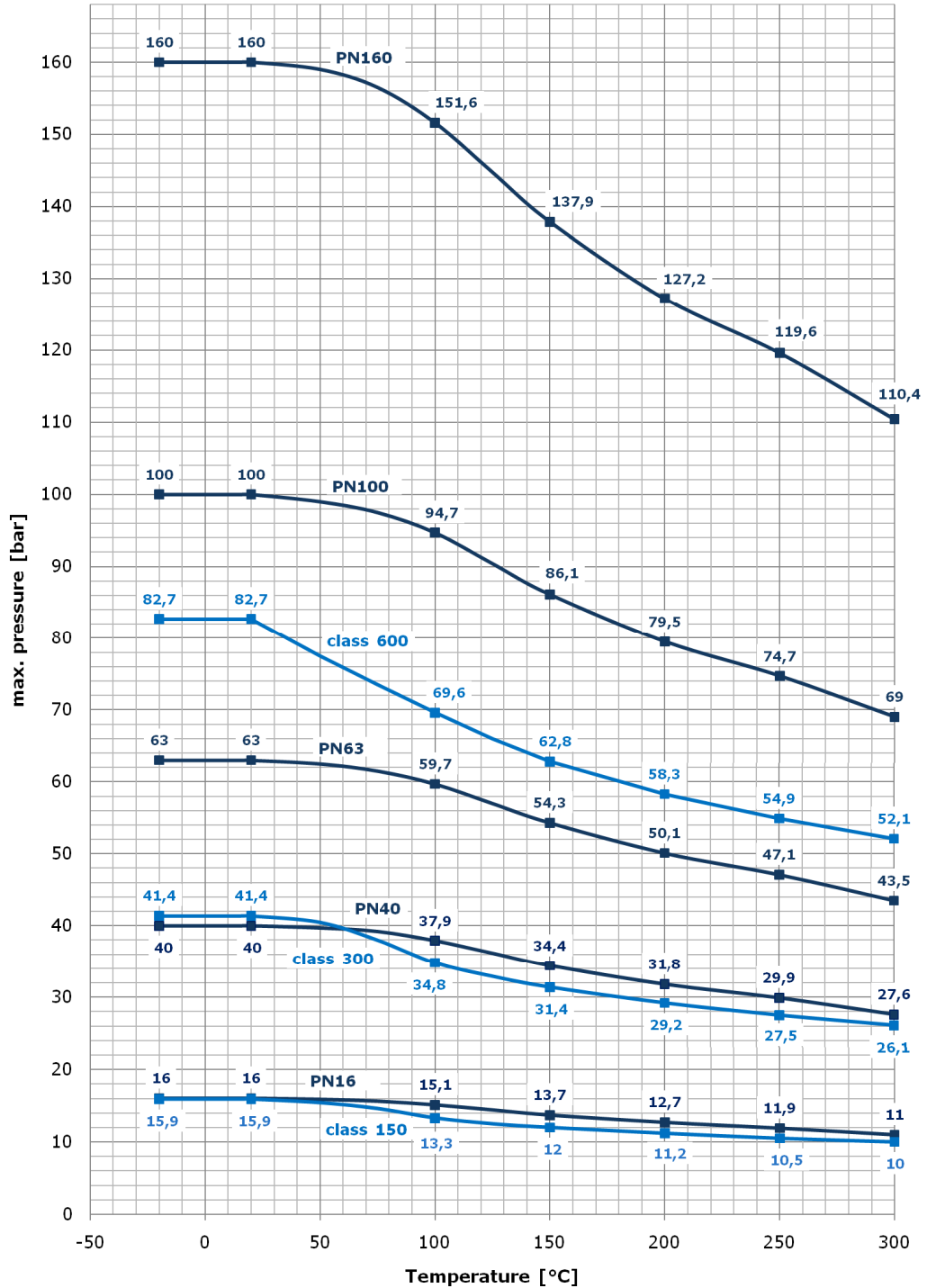

Tab 7.1 Maximum Pressure PS vs. temperature TS

## 7.5 Dimensions and weights

Standard version (Housing of display made of aluminium)

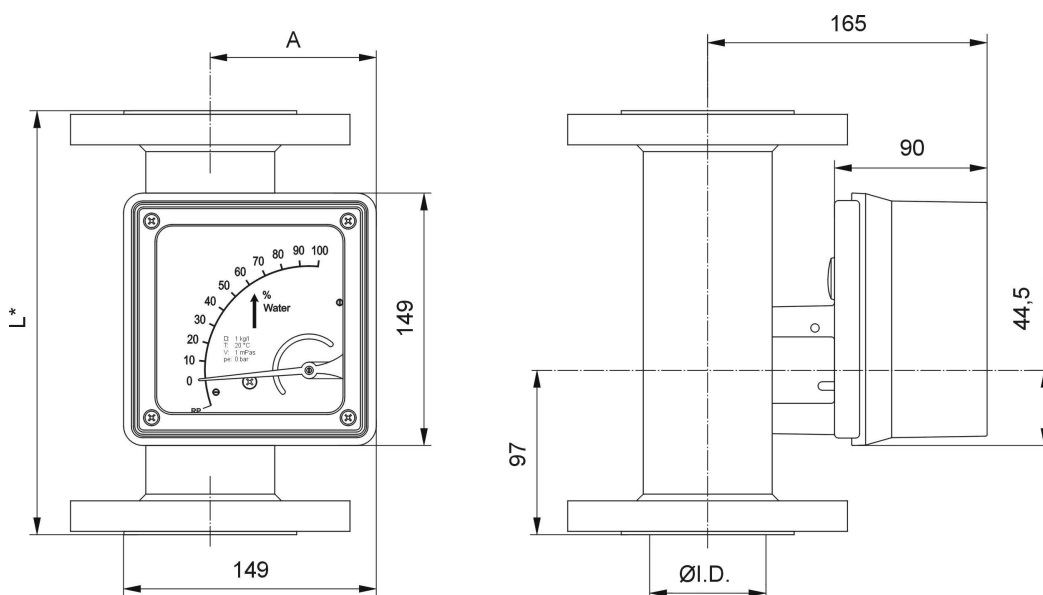

DN	ANSI	Ø I.D.	A	Weight
15	1/2"	26 (1,02)	74 (2,91)	3,0 (6,6)
20	3/4"	26 (1,02)	74 (2,91)	3,0 (6,6)
25	1"	32 (1,26)	77 (3,03)	4,2 (9,3)
32	1 1/4"	32 (1,26)	77 (3,03)	5,2 (11,5)
40	1 1/2"	46 (1,81)	88 (3,46)	6,0 (13,2)
50	2"	70 (2,76)	97 (3,82)	7,5 (16,5)
65	2 1/2"	70 (2,76)	97 (3,82)	8,5 (18,7)
80	3"	102 (4,02)	113 (4,45)	13,0 (28,7)
100	4"	125 (4,92)	126 (4,96)	18,0 (39,7)
125	5"	125 (4,92)	126 (4,96)	22,0 (48,4)
150	6"	125 (4,92)	126 (4,96)	25,0 (55,0)

All Dimensions in mm (inch)

weights in kg (lbs)

Heating jacket version

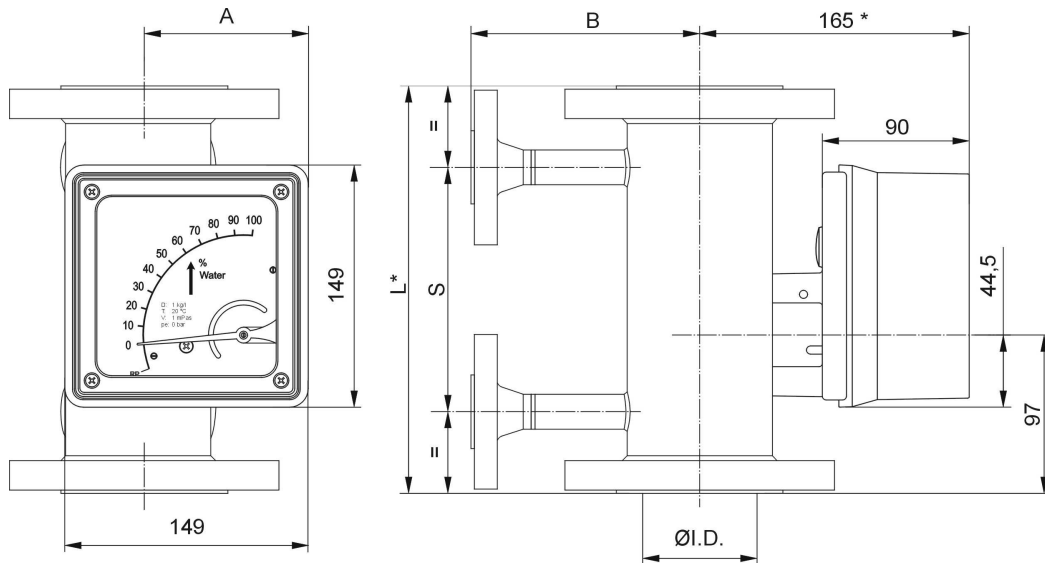

DN	ANSI	Ø I.D.	A	B	S	Weight
15	½"	26 (1,02)	74 (2,91)	110 (4,33)	150 (5,91)	4,7 (10,4)
20	¾"	26 (1,02)	74 (2,91)	110 (4,33)	150 (5,91)	4,7 (10,4)
25	1"	32 (1,26)	77 (3,03)	110 (4,33)	150 (5,91)	5,9 (13,0)
32	1 ¼"	32 (1,26)	77 (3,03)	110 (4,33)	150 (5,91)	6,9 (15,2)
40	1 ½"	46 (1,81)	88 (3,46)	130 (5,12)	150 (5,91)	7,8 (17,2)
50	2"	70 (2,76)	97 (3,82)	140 (5,51)	150 (5,91)	9,6 (21,1)
65	2 ½"	70 (2,76)	97 (3,82)	140 (5,51)	150 (5,91)	11,0 (24,2)
80	3"	102 (4,02)	113 (4,45)	160 (6,30)	150 (5,91)	16,0 (35,2)
100	4"	125 (4,92)	126 (4,96)	175 (6,89)	120 (4,72)	22,0 (48,4)
125	5"	125 (4,92)	126 (4,96)	175 (6,89)	120 (4,72)	26,0 (57,2)
150	6"	125 (4,92)	126 (4,96)	175 (6,89)	120 (4,72)	29,0 (63,8)

All Dimensions in mm (inch)

weights in kg (lbs)

\* For dimension **L** please refer to page 33.

Stainless steel version

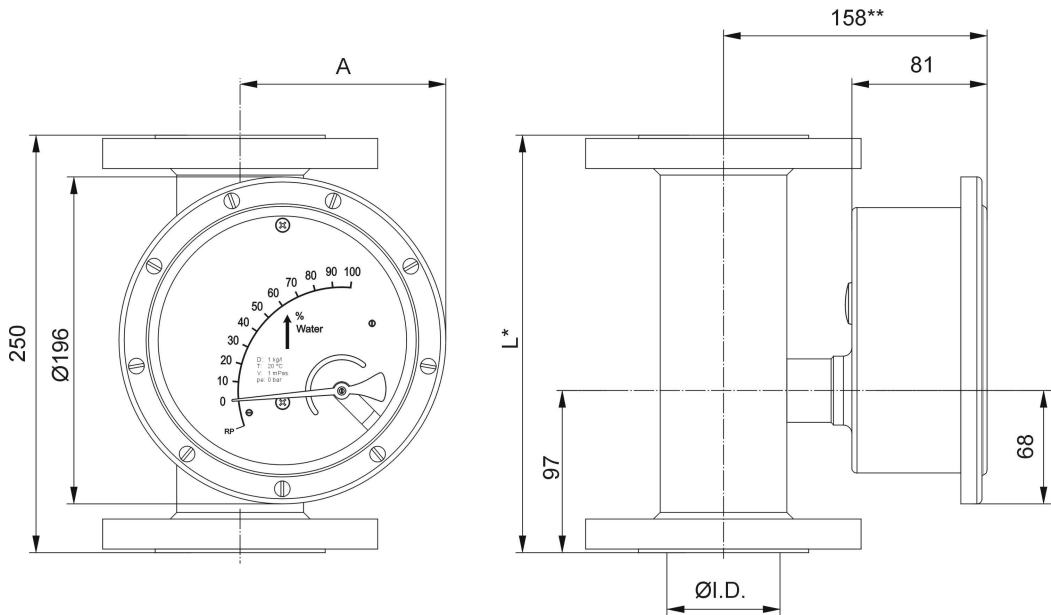

DN	ANSI	Ø I.D.	A	Weight
15	½"	26 (1,02)	103 (4,06)	3,1 (6,8)
20	¾"	26 (1,02)	103 (4,06)	3,1 (6,8)
25	1"	32 (1,26)	105 (4,13)	4,3 (9,5)
32	1 ¼"	32 (1,26)	105 (4,13)	5,3 (11,7)
40	1 ½"	46 (1,81)	115 (4,53)	6,1 (13,4)
50	2"	70 (2,76)	129 (5,08)	7,6 (16,7)
65	2 ½"	70 (2,76)	129 (5,08)	8,6 (18,9)
80	3"	102 (4,02)	145 (5,71)	13,1 (28,9)
100	4"	125 (4,92)	158 (6,22)	18,1 (39,9)
125	5"	125(4,92)	158 (6,22)	22,1 (48,6)
150	6"	125(4,92)	158 (6,22)	25,1 (55,2)

All Dimensions in mm (inch)

weights in kg (lbs)

\* For dimension **L** please refer to page 33.

\*\* Dimension will be 258mm for version with displaced display unit

Mounting dimension L

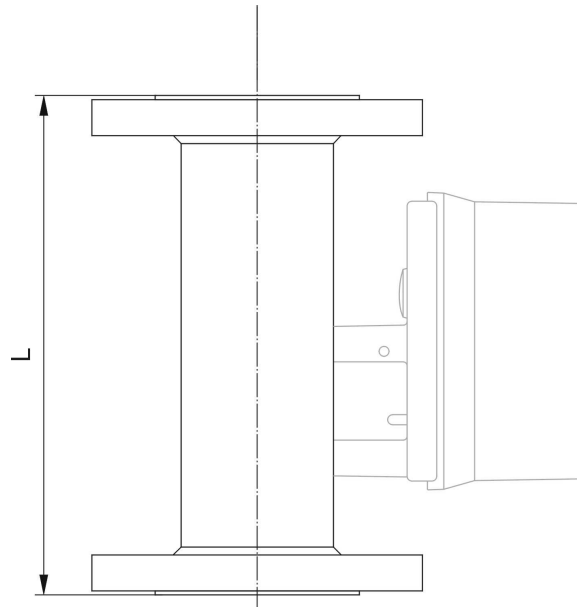

Nom. Dia.	EN				Nom. Dia.	ANSI		
	PN 16	PN 40	PN 63	PN 100		150 lbs	300 lbs	600 lbs
DN 15	◇	250	◇	250	1/2"	250	250	250
DN 20	◇	250	◇	250	3/4"	250	250	250
DN 25	◇	250	◇	250	1"	250	250	250
DN 32	◇	250	◇	250	1 1/4"	250	250	250
DN 40	◇	250	◇	250	1 1/2"	250	250	250
DN 50	◇	250	250	300	2"	250	250	300
DN 65	250	250	◇	◇	2 1/2"	250	300	300
DN 80	250	250	◇	◇	3"	250	300	300
DN 100	250	250	◇	◇	4"	250	300	300
DN 125	250	300	◇	◇	5"	250	300	◇
DN 150	250	300	◇	◇	6"	250	300	◇

All Dimensions in mm

◇ = not available

**Devices with threaded connection:**

Mounting dimension L: 300 mm



**Mecon GmbH**

Röntgenstraße 105  
D 50169 Kerpen

Tel.: +49 (0)2237 600 06 - 0  
Fax.: +49 (0)2237 600 06 - 20  
Email: [customerservice@mecon.de](mailto:customerservice@mecon.de)

[www.mecon.de](http://www.mecon.de)

