

Sensor KIS 2

Operating and Maintenance Manual BVC0017

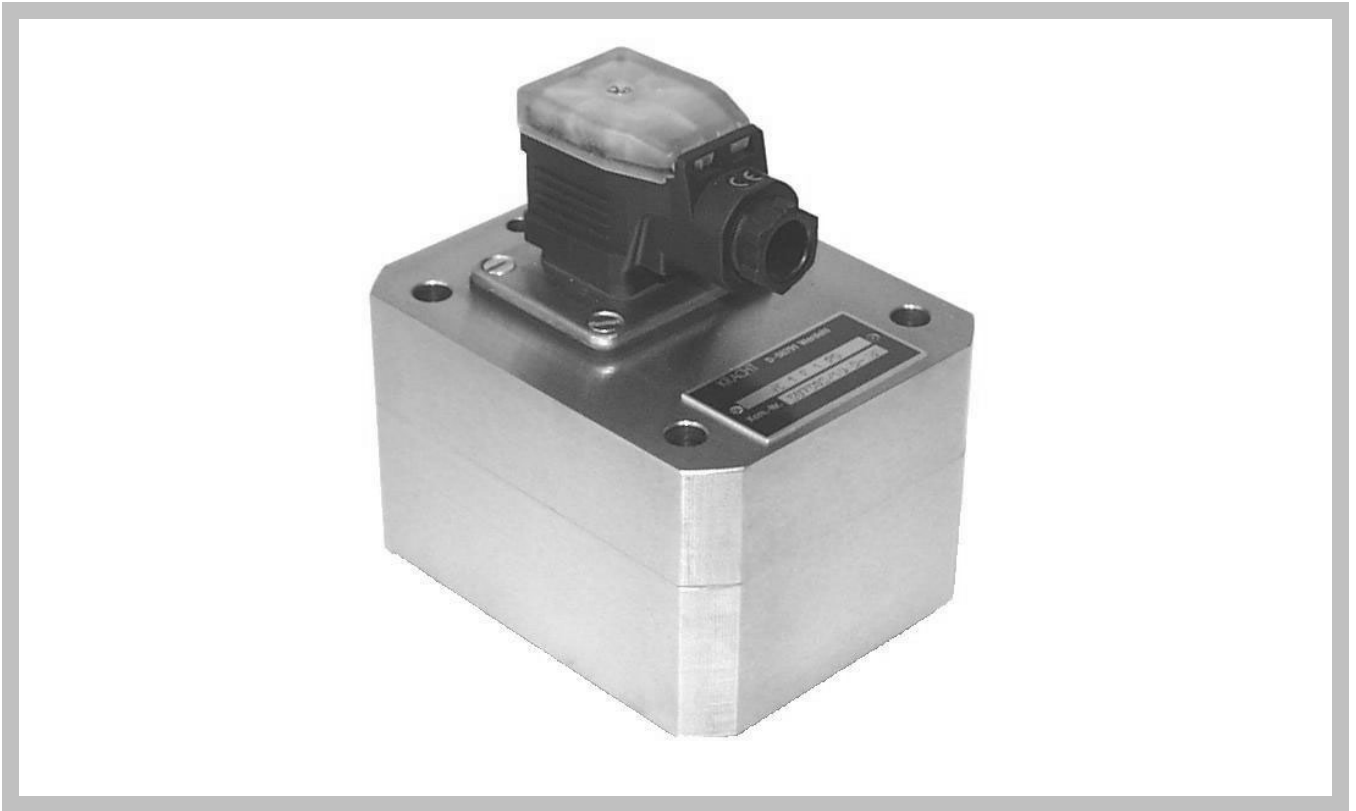

⊕ II 2 G EEx ia IIC T4

⊕ II 2 D Ex iaD 21 T 125°C

⊕ I M 2 EEx ia I

$-30^{\circ}\text{C} \leq T_a \leq +80^{\circ}\text{C}$

Contents

Safety	3
Designation of Safety Instructions	3
General Safety Instructions	3
Manufacturer's address	3
The documentation	4
Explosion protection	4
Proper use	4
Identification	5
Technical data	5
Construction and function	5
Permissible operating pressures and media	6
Permissible temperatures	6
Definitions of electrical values of circuits	6
Electrical data of isolating amplifier K-130/3-E-10	6
Installation, Commissioning	7
Installation and removal	7
Safety instructions	7
Electrical connection	7
Terminal allocation	8
Connecting to switch amplifier	9
Operation	10
Maintenance	10
Cleaning	10
Recognizing and Eliminating Disruptions	11
Return	11
Disposal	11
Declaration of Conformity	12

Safety

Designation of Safety Instructions



The safety instructions provided in this operating manual are designated with the warning symbol. Failure to follow these instructions could lead to personal injury or damage to equipment.



Other instructions that are not hazard warnings, but give tips for better working, are designated by a hand.



Additional safety instructions for explosion protection are designated with the Ex symbol.

General Safety Instructions



Safety in operating the device supplied is only guaranteed if it is operated properly. The limit values specified (see chapter "Technical data") must not be exceeded under any circumstances.

The personnel entrusted with the fitting, operation and maintenance of the Sensor KIS 2 and the corresponding measuring equipment must be suitably qualified; this can be through training or by appropriate instruction. These personnel must be familiar with the instructions provided in this manual.

All work done must conform to the existing national regulations on accident prevention and health and safety at work, and to any existing internal regulations of the customer or operator, even if they are not specified in this manual.

The connecting conduits must be de-pressurized for all work on the measuring equipment and prior to its removal!

The customer or operator must ensure that this operating manual is permanently accessible to the persons concerned.

Manufacturer's Address

KRACHT GmbH
 Gewerbestrasse 20
 58791 Werdohl

Tel. 02392 / 935-0
 Fax 02392 / 935209
 E-mail: info@kracht-hydraulik.de
 Internet: www.kracht-hydraulik.de

The Documentation

This manual describes the construction, operation and maintenance of the Sensor KIS 2 manufactured by KRACHT GmbH.

The device is manufactured in several versions and is only supplied in connection with the corresponding measuring equipment. The model is shown on the name plate of each sensor.

In this operating and maintenance manual, a total item of equipment, which consists of Sensor KIS 2 and measuring equipment, is designated as a gear flowmeter. In some places reference is made to the operating and maintenance manual of the gear flowmeter.

An explanation of the type code and a more detailed description of the individual series and nominal sizes are given under "Technical data" and in the section entitled "Description of the equipment" in the operating and maintenance manual of the corresponding gear flowmeter.

Explosion Protection



This manual is only valid in connection with the BVC.... operating and maintenance instructions for the relevant gear flowmeter. All information contained in it with reference to safety and explosion protection must also be observed.

The KIS 2 sensor may only be operated in connection with a switching amplifier approved for the corresponding ATEX application. The operating instructions of this amplifier have to be precisely observed. Type K-130/3-E-10 is recommended. This isolating amplifier is harmonised with the KIS 2 sensor.

The relevant legal regulations and instructions given in the respective operating and maintenance manual must be observed for items of equipment which fall under the ATEX guideline (Explosion protection).

The sensor or connector may not be opened or connected in a dust atmosphere which gives rise to risk of explosion.

Proper Use

The items of equipment are only approved for appropriate use in accordance with the regulations. The maximum permissible operating data given in the "Technical Data" section must be observed without fail.

Nameplates or other references on the device may not be removed or made illegible or unrecognizable. In the event of non-compliance, any guarantee and manufacturer responsibility is forfeited.

Identification

Kracht GmbH Werdohl
 Sensor KIS 2 CE 0102
 PTB 03 ATEX 2249

 II 2 G EEx ia IIC T4

bzw.  II 2 D Ex iaD 21 T125°C

bzw.  I M 2 EEx ia I

$-30^{\circ}\text{C} \leq T_a \leq +80^{\circ}\text{C}$

Type designation
 Product No.
 Job No. Production Date

Note:

The KIS 2 sensor is manufactured in several versions and is only supplied in connection with the corresponding measuring equipment. Type designation, product and job nos. as well as date of production therefore always refer to a complete gear flowmeter.

Technical Data

Construction and Function

The KIS 2 sensor is used in fluid handling systems for measurement of throughput. It is a piece of intrinsically safe electrical apparatus of Categories 2 and 3 (EEx ia IIC T4) and can be used in intrinsically safe electrical circuits in Zones 1, 2, 21 and 22 as well as in Category I M2.

The KIS 2 sensor represents the electrical portion of the gear throughput gauge from KRACHT GmbH, which can be manufactured in different sizes and materials (without influence on electrical explosion protection).

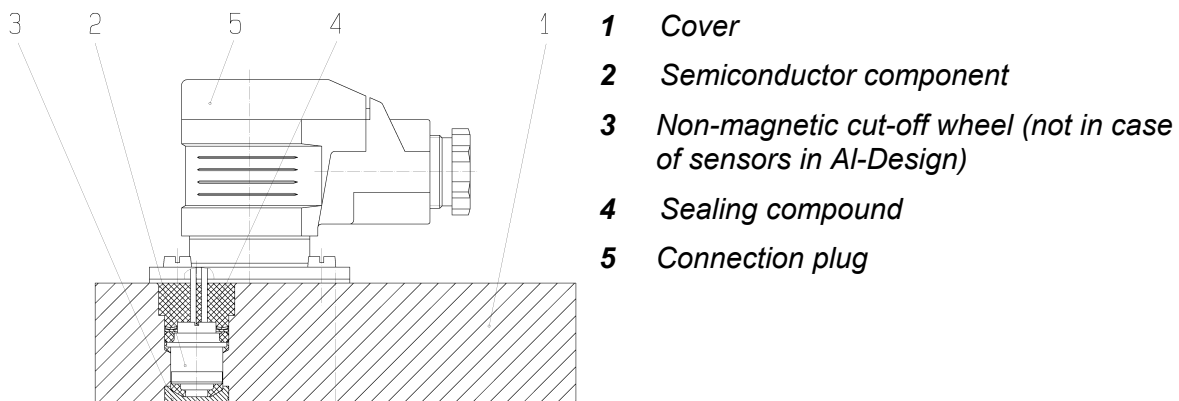

Permissible Operating Pressures and Media

See operating and maintenance instructions for the gear flowmeter

Permissible Temperatures

	Permissible temp. range	Remarks
operating media temperature	-30°C ... +80°C	
Ambient temperature	-30°C ... +80°C	
Sensor KIS 2 with connector socket	-30°C ... +80°C	
Standard cable LiYCY	-10°C ... +80°C	
Special cable ÖLFLEX EB CY installed fixed	-30°C ... +80°C	Min. bending radius: 6 x outer diameter
Pecial cable ÖLFLEX EB CY flexibly installed	-5°C ... +70°C	Min. bending radius: 20 x outer diameter

Definitions of Electrical Values of Circuits

Max. voltage	$U_i = 20 \text{ Volt}$
Max. current	$I_i = 100 \text{ mA}$
Max. power	$P_i = 550 \text{ mW}$
Inner capacity	$C_i = \text{negligible}$
Inner inductivity	$L_i = \text{negligible}$

Electrical Data of Isolating Amplifier K-130/3-E-10

Number of measurement channels	1 bzw. 2
Rated voltage	$U_B = 24 \text{ V DC} \pm 20\%$, secure against reverse polarity
Pulse wave shape with symmetrical output signal	Rechteck, Tastverhältnis/Kanal 1:1 $\pm 15\%$
Pulse offsetting between both channels	$90^\circ \pm 30^\circ$
Power requirement	$P_{b \text{ max}} = 3,6 \text{ W}$
1 open collector output per channel	$U_{\text{max}} = 30 \text{ V AC/DC} - 20 \text{ mA}$

Installation, Commissioning

Installation and Removal

The KIS 2 sensor is only supplied in connection with the corresponding measuring equipment. Installation and removal of the gear flowmeter are described in the corresponding operating and maintenance instructions.



It must be observed that the Gear Type Flow Meter is only held by the housing during assembly and transport and never by the attached plug!



The relevant legal regulations and instructions given in the respective operating and maintenance manual must be observed for items of equipment which fall under the ATEX guideline!

Safety Instructions

- The devices can be installed within the Ex area in Zones 1 or 2 (Category 2 or 3). The installation must be carried out in accordance with the valid installation procedures for intrinsically safe operating equipment.
- Use of the device in coal mining below ground in the "switch-off area" (Category M2) is also permissible. However, this does not apply for devices made of aluminium.
- The devices are designed to Protection Class IP 65 and must be appropriately protected in unfavourable environmental conditions, such as in the presence of water spray or dirt or damp which go beyond Fouling Grade 2.
- The devices must be protected against electrostatic discharge; the housing of the equipment must be electrostatically earthed (e.g. by means of metallic pipes).
- The device may only be used for the intended purpose.
- Linking with associated and/or non-safe equipment must be reviewed separately.
- The plug must not be pulled out in the dust Ex area.
- The device must also be supplied with power so as to be intrinsically safe in the dust Ex area.
- No changes may be made to the device.

Electrical Connection



The accepted rules of technology must be observed when installing and dismantling the device. In particular when working with electrical equipment, the special safety regulations must be observed. Such work may only be carried out by an electrical specialist!

- Electrical connection is by means of the connection terminals of the connector which is supplied with the device.
- Particular attention must be paid to proper installation and maintenance of the IP protection.
- Torque must not be transferred to the connector cables.
- The connector cable must be approved for use with intrinsically safe devices. Limit temperatures must be observed. Corresponding cables may be purchased from Kracht.

Terminal Allocation

Connection of the intrinsically safe circuits is carried out at the terminals of the relevant connector:

Circuit/Channel 1

- Contact 1 : Plus
- Contact 4 : Minus

Circuit/Channel 2

- Contact 3 : Plus
- Contact 2 : Minus

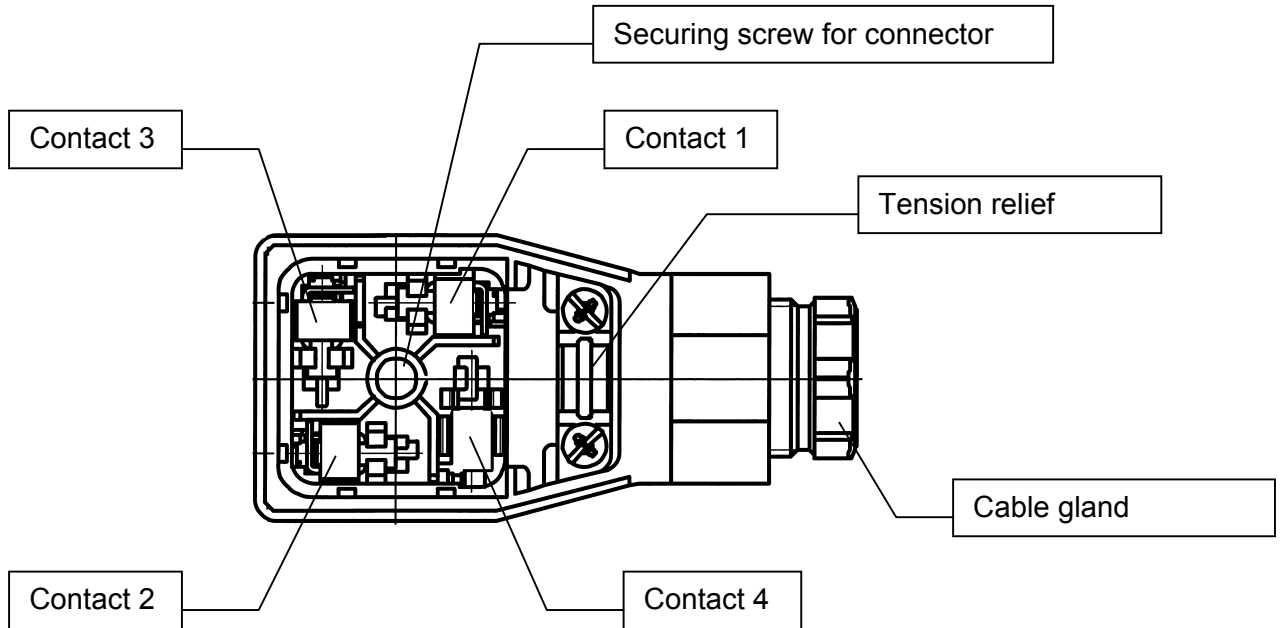

The terminal configuration for Channel 1 or 2 influences the indicated rotation direction of the gearwheels, and therefore the polarity sign with which the measured volume current is displayed in the evaluation device.



After installation, the screws of the tension relief device, the cover and the cable screw connection must be tightened.

Connecting to Switch Amplifier



The relevant legal regulations and instructions given in the respective operating and maintenance manual must be observed for items of equipment which fall under the ATEX guideline!



The recognised rules of technology must be observed when mounting and removing the device. In particular when working on electrical equipment, the special safety regulations must be observed. This work may only be carried out by an electrical specialist.

The illustration schematically shows connection of isolating amplifier K-130/3-E-10 to Kracht sensor KIS 2. The operating and maintenance instructions of both devices must be observed without fail.

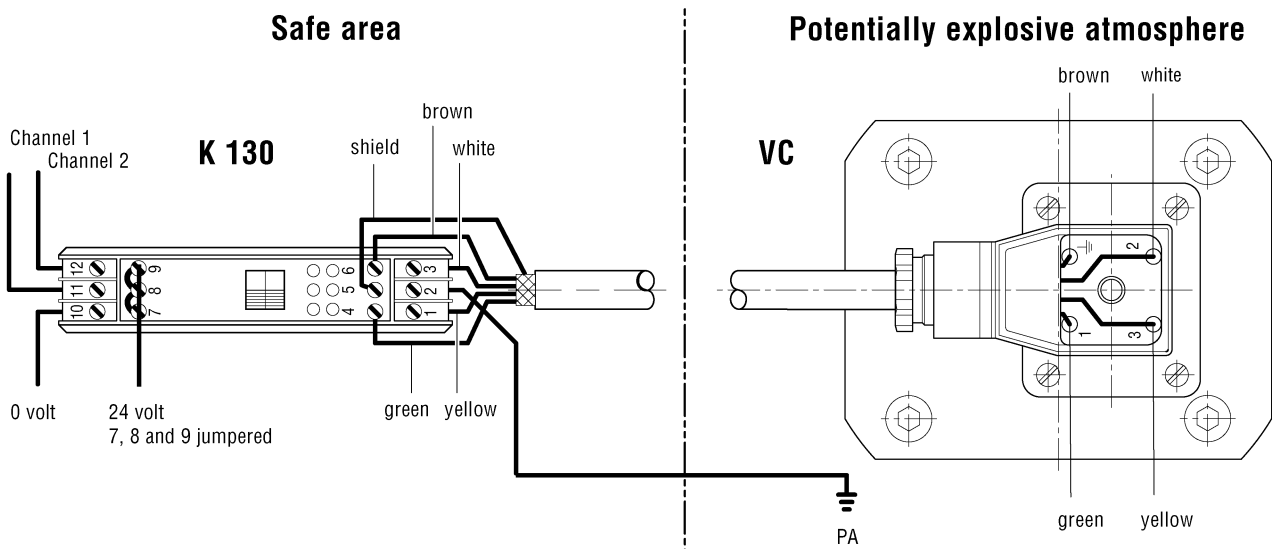

Conductor cross-section for potential equalisation $\geq 1,5 \text{ mm}^2$

Operation



Sensor KIS 2 may only be operated within the given limit values (see Chapter "Technical Data" in these instructions).



It must be ensured that the medium to be measured does not attack the material of the sensor. The medium may not contain any abrasive particles. In case of doubt, please consult the manufacturer.

The maximum permissible operating data described in the "Technical Data" chapter of the standard operating and maintenance instructions must be observed without fail.

The KIS 2 with the associated measuring equipment was checked before despatch from the factory. It can be directly put into operation as soon as the mechanical and electrical connections have been created. Both LEDs on the isolating amplifier are illuminated during operation as long as a continuous stream of liquid is flowing through the measuring device. Errors are shown by the associated evaluation device. The actions which must be taken in case of error and disturbance may be read in the "Recognising and eliminating errors" chapter.

Maintenance



No changes may be made to the device.

The transmission behaviour of the device is stable over long periods of time. Regular adjustment or similar is therefore not necessary. No other maintenance work is necessary. As soon as defects are noticed in the device, remove the complete gear flowmeter. The interior components of the sensor cannot be maintained by the customer. Return the complete gear flowmeter to the manufacturer for maintenance.

Cleaning

Dust deposits on the sensor or the gear flowmeter must be avoided at all costs. Regular cleaning is therefore essential. The cleaning interval depends on local conditions and must therefore be specified and ensured in practice by the operator.

Recognizing and Eliminating Disruptions

In the event that the Gear Type Flow Meter does not work properly, then the electrical components should be examined first. The measuring device must remain in operation for this. Störungen erkennen und beseitigen.



This work may only be conducted by qualified electricians.

If non-identifiable errors occur, seek help from Kracht or return the device to Kracht for checking.



It is not possible to repair the sensor.

If there is no analytical evaluation software, then defect analysis should proceed according to the following defect search chart.

Defect	Possible Cause	Elimination
Both LED displays on the disconnection switch amplifier are lighting, but displaying incorrect values.	The connection between the Gear Type Flow Meter and the evaluation device is disrupted.	Inspect the connection and replace the cable or plug is necessary.
One LED display is not lighting during operation.	The wiring between the sensor and circuit board or between individual soldering joints and the circuit board are damaged.	Send the measuring device to the manufacturer for repair.
	The affiliated sensor is defective.	Send the measuring device to the manufacturer for repair.
Both LED displays are not lighting during operation.	Electricity supply breakdown	Examine the mains cable and fuses.
	Since it is improbable that both sensors break down, it is to be assumed that the meter is stuck.	Shut down operation of the Gear Type Flow Meter immediately! Send devices from the Product Lines 1, 2, 6, 7 and 8 to the manufacturer for repair. Devices from Product Lines 3, 4 and 5 can be dismantled and cleaned (see chapter, "Maintenance" in the operating and maintenance manual of the gear flowmeter.).

Return

The device must be appropriately packed in the event of repair or inspection at the manufacturer factory. Furthermore, a safety specification sheet on the medium used must accompany the device. In the case of recognized mineral oils, at least the precise type designation is required. The device must be rinsed out in the event of hardening or adhesive mediums.

Disposal

The packaging and the used parts have to be disposed of in accordance with the regulations of the country where the equipment is installed.

Declaration of Conformity

EC Declaration of Conformity in accordance with Directive 94/9/EC

Hierwith, Kracht GmbH
 Gewerbestr. 20
 D-58791 Werdohl

as the manufacturer, declares that the following device fulfils the requirements laid down in Annex II of Directive 94/9/EC for conception and construction of devices for use in accordance with the specification and regulations in areas at risk from explosion:

Sensor KIS 2

EC Type test certificate no. PTB 03 ATEX 2249

This only applies when the particular conditions in operating and maintenance manual "BVC0017" are observed.

The basic safety and health requirements are fulfilled through agreement with

- EN 50014:1997 + A1 +A2
- EN 50020:2002
- prEN 61241-0:2002
- 31H/143/CD (IEC 61241-11):2002

The machines bear the following identification marking:

 II 2 G EEx ia IIC T4

bzw.  II 2 D Ex iaD 21 T 125 °C

bzw.  I M2 EEx ia I

$-30^{\circ}\text{C} \leq T_a \leq 80^{\circ}\text{C}$

The technical documents in accordance with Directive 94/9/EC Annex VIII are filed with the following notified body:

Physikalisch-Technische Bundesanstalt
 Bundesallee 100
 D-38116 Braunschweig
 EU Ident. No. 0102

Werdohl, 12 March 2004

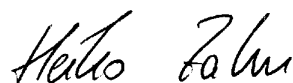

Heiko Zahn
 Chief Executive