

# Volume Counter VC



*VC 0,025 ... VC 16*

## Contents

<b>Safety</b>	<b>3</b>
Designation of Safety Instructions	3
General Safety Instructions	3
Manufacturer Address	3
<b>Documentation</b>	<b>4</b>
<b>Description of the Equipment</b>	<b>4</b>
Proper Use	4
Construction and Function	4
Special Conditions	5
Special Conditions	5
<b>Technical Data</b>	<b>6</b>
Explanation of the Type Code	6
General Specifications	7
Permissible Operational Media Temperature	7
Overview - Rated Quantities	8
Overview Series and Materials	9
Dimensions	10
Connection Plates	17
<b>Installation and Removal of the Volume Counter</b>	<b>22</b>
Corrosion Protection	22
Mechanical Installation	22
Plate Connection	22
Mounting onto Extraneous Connection Plates or Valve Blocks	23
Pipe Connection	23
Electrical Connection	24
<b>Operation</b>	<b>25</b>
Permissible Limiting Values for Operation	26
<b>Maintenance</b>	<b>26</b>
<b>Cleaning</b>	<b>26</b>
Housing Connection Tightening Torque, Series 3, 4 and 5	27
<b>Recognizing and Eliminating Disruptions</b>	<b>27</b>
Return	27
Disposal	28

## Safety

### Designation of Safety Instructions



The safety instructions provided in this operating manual are designated with the warning symbol. Failure to follow these instructions could lead to personal injury or damage to equipment.



Other instructions that are not hazard warnings, but give tips for better working, are designated by a hand.

### General Safety Instructions



Safety in operating the equipment supplied is only guaranteed if it is operated properly (see chapter entitled "Description of the Equipment"). The limit values specified (see also chapter entitled "Technical Data") must not be exceeded under any circumstances. The personnel entrusted with the installation, operation and maintenance of the device must be suitably qualified; this can be through training or by appropriate instruction. These personnel must be familiar with the instructions provided in this manual. All work done must conform to the existing national regulations on accident prevention and health and safety at work, and to any existing internal regulations of the operator, even if they are not specified in this manual. Leaks of hazardous materials that are conveyed must be collected and disposed of in such a way that there is no danger to persons or to the environment. Statutory regulations must be observed in such cases. The connecting conduits must be depressurized for all work on the device and before it is dismantled! The operator must ensure that this operating manual is permanently accessible to the persons concerned. In the event of a blockage of the volume counter, then this works like a closed slider. As a result of the uncontrollable degrees of pressure that appear in such cases, damages to the volume counter and to the upstream facility elements can occur. For this reason, the application of a pressure limiter before the volume counter is indispensable. In the event of an unplanned breakdown of the counter signal, for example as a result of a blockage of the meter, the system must be shut down immediately.

### Manufacturer Address

KRACHT GmbH  
 Gewerbestrasse 20  
 58791 Werdohl

Tel. 02392 / 935-0  
 Fax 02392 / 935209  
 E-mail: [info@kracht-hydraulik.de](mailto:info@kracht-hydraulik.de)  
 Internet: [www.kracht-hydraulik.de](http://www.kracht-hydraulik.de)

## Documentation

This manual describes the installation, operation and maintenance of the KRACHT Volume Counter VC.

The device is manufactured in a variety of models. The individual model at hand can be gathered from the nameplate on the device. An explanation of the type code and a more detailed description of the individual series and nominal sizes are given in the chapters, "Technical Specifications" and "Description of the Equipment".

## Description of the Equipment

### Proper Use

The Volume Counter is a measuring device for the continuous flow measurement of combustible and non-combustible fluids. The various Series allow the use of mediums of differing viscosity and lubricating capabilities.



**It must be assured that the fluid medium to be measured is compatible with the materials used in the Volume Counter (see chapter, "Technical Data. Chemical competence is required for this.**

**The maximum permissible operation data in the chapter, "Technical Data", is to be observed without exception.**

**Nameplates or other references on the device may not be removed or made illegible or unrecognizable. In cases of infringement, all guarantees and manufacturer's responsibility on the part of KRACHT GmbH expire.**

### Construction and Function

The principle construction of the individual VC Series is depicted in the illustration below using the example of Series 1 and 2.

The movement of the gear wheels is gauged by two non-contact object sensors and converted into electrical signals. A compression-proof, non-magnetic insulation plate is located between the sensor space and the measuring chamber. These signals are forwarded to the attached display unit.

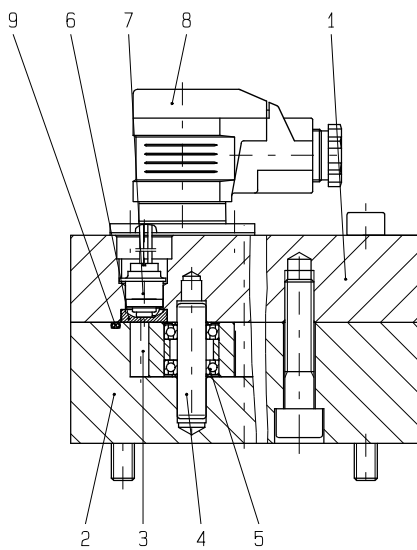

- 1** Cover
- 2** Housing
- 3** Gearwheel
- 4** Bearing Neck
- 5** Bearing  
Series 1, 2, 6, 7, 8 Ball bearing  
Series 3, 4, 5 Plain bearing (not depicted)
- 6** Non-magnetic insulation plate
- 7** Sensor
- 8** Connection plug
- 9** O-Ring

---

## **Special Conditions**

**Special conditions or restrictions apply for the safe use of the volume counters in a permissible environment. These must be provided by the customer or operator by means of appropriate technical and/or organizational measures.**

**Operation is only permissible within the specified environmental and surroundings conditions.**

**The volume counters may only be used if their materials are resistant against mechanical and/or chemical influences or corrosion.**

**The medium must have a minimum lubricity.**

**The volume counter is designed for operation with fluids. Dry operation is not permissible. Operation outside the permitted parameters is prohibited.**

**If necessary, a filter is to be installed in order to prevent blockage of the volume counter by foreign substances.**

**The installation, servicing and maintenance provisions specified in the operating instructions are to be complied with without exception.**

**The volume counters may only be operated when closed and may not be exposed to impermissible vibrations.**

**Only original replacement parts may be used in maintenance and servicing.**

## Technical Data

### Explanation of the Type Code

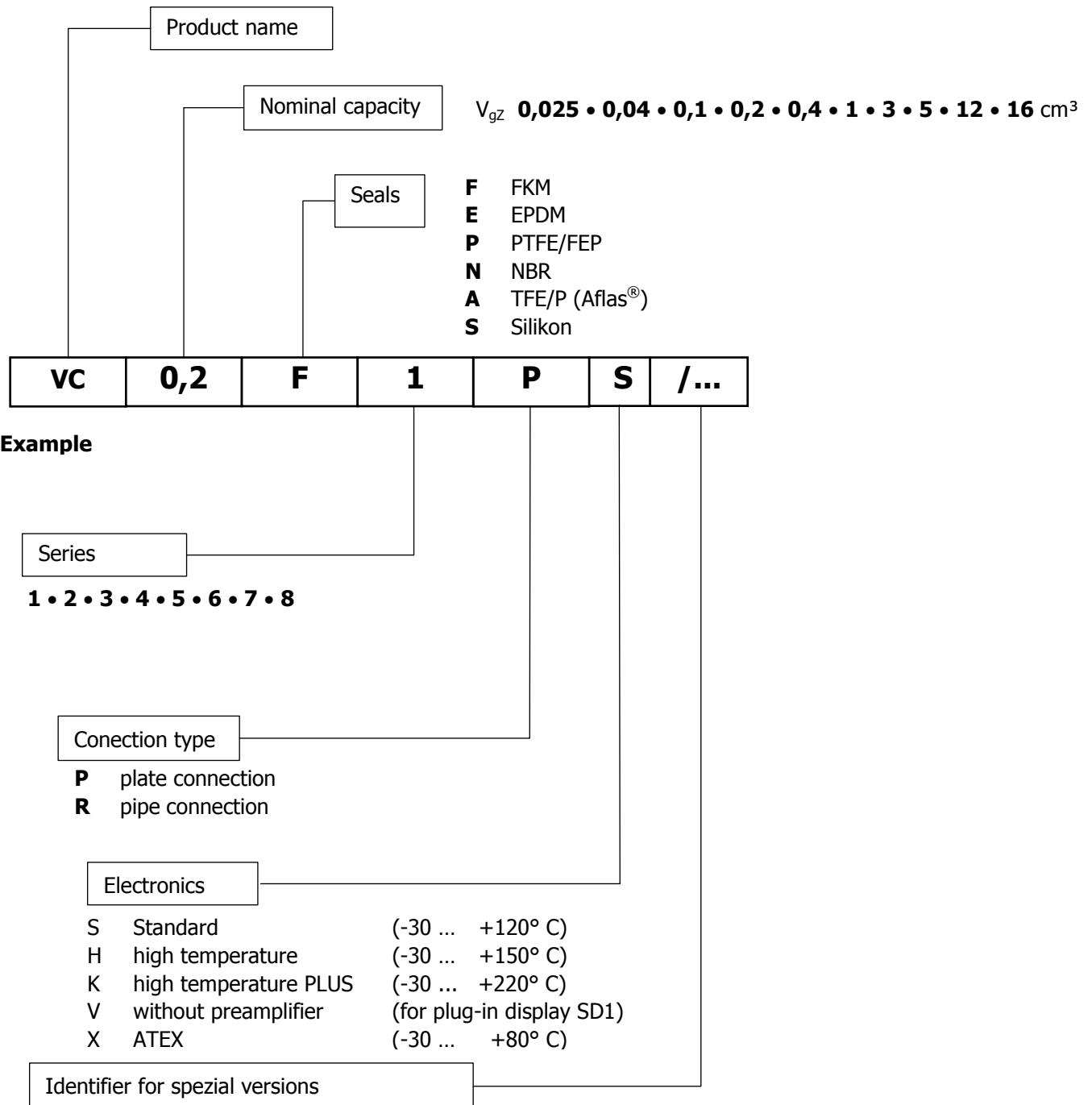

### General Specifications

Type	Geared motor
Materials	See overview, "Series and Materials"
Branch Circuit Connection	Plate construction or pipe thread
Fitting Position/Flow Direction	Optional
Permissible Environmental Temperature	-30 to +80 °C

### Permissible Operational Media Temperature

Sealing Variations	Model	<b>S</b> Standard °C	<b>H</b> High Temperature °C	<b>K</b> High Temperature PLUS °C
<b>F</b> FKM		-15 ... 120	-15 ... 150	-15 ... 150
<b>E</b> EPDM**		-30 ... 120	-30 ... 130	-30 ... 130
<b>P</b> PTFE/FEP		-30 ... 120	-30 ... 150	-30 ... 220
<b>N</b> NBR		-30 ... 100	-30 ... 100	-30 ... 100
<b>A</b> TFE/P (Aflas®)		-10 ... 120	-10 ... 150	-10 ... 200
<b>S</b> Silicon		-30 ... 120	-30 ... 130	-30 ... 130

\* The operating media temperature refers to mineral hydraulic fluids (e.g. HLP), other media can require different media temperate limits !

\*\* The operating media temperature refers to the brake fluid (DOT3/DOT4)

## Overview - Nominal capacities

Nominal capacity*		0,025	0,04	0,1	0,2	0,4	1	3	5	12	16
Geom.Tooth Volume	cm <sup>3</sup>	0,025	0,04	0,1	0,245	0,4	1,036	3,000	5,222	12,0	16,0
Resolution	Imp/l	40000	25000	10000	4082	2500	965	333	191,5	83,3	62,5
Max. Operational Pressure	bar	400	400	400	400	400	400	315	315	400	400
Peak Pressure	bar	480	480	480	480	480	480	350	350	480	480
Measurement Range**	1	0,008...2	0,02...4	0,04...8	0,16...16	0,2...40	0,4...80	1...250	0,6...160	2,0...600	2,5...700
	2	-	-	-	0,16...16	-	0,4...80	1...250	-	-	-
	3	-	-	-	-	-	0,6...40	1,2...80	-	-	-
	4	-	-	-	0,16...16	0,2...30	0,3...60	1...160	0,6...100	-	-
	5	0,02...2	-	-	0,16...16	-	0,3...60	1...160	0,6...100	-	-
	6	0,008...2	0,02...4	0,04...8	0,16...16	-	0,4...80	1...250	0,6...160	-	-
	7	0,008...2	0,02...4	-	0,16...16	-	0,4...80	-	-	-	-
	8	0,008...2	0,02...4	-	0,16...16	-	0,4...80	-	-	-	-
Sound Pressure Level	dB(A)	< 60	< 60	< 60	< 60	< 70	< 70	< 70	< 72	< 80	< 80

\* See model designation on device: VC...

\*\* Restrictions of the measurement range are possible in the case of higher viscosities in the conveyance medium.

**The max. pressure loss in the volume counter may not exceed 16 bar.**

Series		1	2	3	4	5	6	7	8
<b>Material</b>	<b>Housing Cover</b>	EN-GJS-400-15 (GGG 40) VC 3/79, VC 5/79, VC 12 a. VC 16: EN-GJS-600-5 (GGG60)				1.4404		EN-GJS-400-15	1.4404
	<b>Measuring unit</b>	1.7139 (case-hardened steel)				1.4462		1.7139	1.4462
	<b>Bearing</b>	Roller Bearing Steel	Sn-Bronze	Hard Metal		SS roller bearing steel	Roller bearing steel/ ceramic balls		
<b>Type of bearing</b>		Roller Bearing		Ball Bearing			Roller Bearing		
<b>Viscosity of the fluid handled in mm<sup>2</sup>/s</b>		1 ... 3000	5 ... 5000	200 ... 500000	50 ... 5000	50 ... 5000	1 ... 3000	1 ... 3000	1 ... 3000
<b>Lubricity of the fluid handled</b>		Good			Bad		Good	Bad	
<b>Permissible foreign particle size in fluid handled in μm</b>		20	30	50	30		20		

Overview Series and Materials

## Dimensions

### Series 1, 2, 3, 4 and 7 - Connection Type P Version S, H

Ordering code VC ... ..

Nominal size	Available Series	Weight kg	Tightening torque Nm	Dimensions											
				$M_A$	A	C	D	F	$G_S$	$G_H$	J	K	L	M	N
0,025	1, 7	1,8	14	85	10	60	50	101	113	-	70	40	20	6,5	M6
0,04	1, 7	2	14	85	9	60	56	107	119	-	70	40	20	6,7	M6
0,1	1, 7	2,3	14	85	10	60	65	116	128	-	70	40	20	6,7	M6
0,2	1, 2, 4, 7	2	14	85	13	60	57	108	120	-	70	40	20	9	M6
0,4	1, 4	3,7	35	100	17	90	63	114	126	-	80	38	34	16	M8
1	1,2,3,4,7	5,2	35	120	13	95	72	123	135	15,5	84	72	35	16	M8
3	1, 4	9	145	170	18	120	89	140	152	46,5	46	95	50	25	M12
5	1, 2, 3, 4, 7	13	145	170	22	120	105	156	168	46,5	46	95	50	25	M12

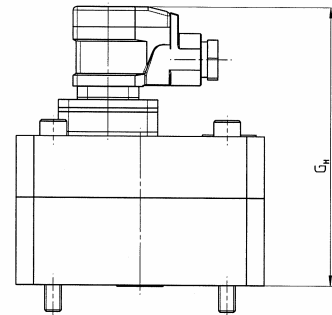
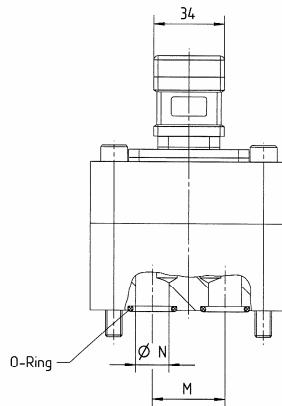
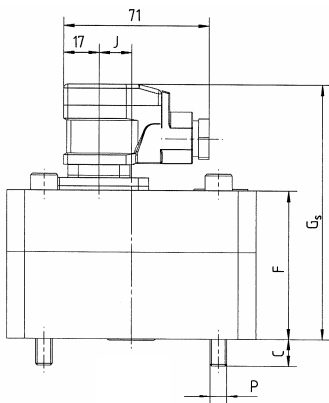

### Design S

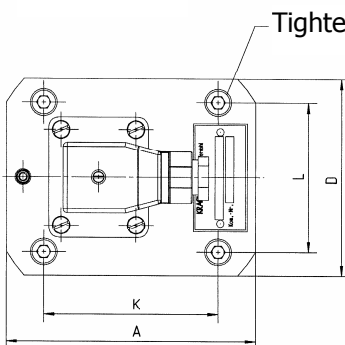

### Design H

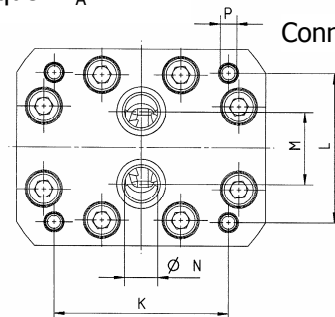

**Series 1 - Connection Type P Version S, H**

Ordering code VC ... ..

Nominal size	Available series	Weight kg	Tightening torque Nm	Dimension										
				$m$	$M_A$	C	D	F	$G_S$	$G_H$	J	K	L	M
VC 3 /79 *	1	16,3	145	24,5	180	99	150	163	46,5	46	95	50	25	M12
VC 5 /79 *	1	22	145	22	180	115	166	179	46,5	46	95	50	25	M12
VC 12	1	58,4	400	44	249	168	219	232	77	120	140	70	38	M20
VC 16	1	58,4	400	44	249	168	219	232	77	120	140	70	38	M20

\* high pressure variant VC 3 and VC 5

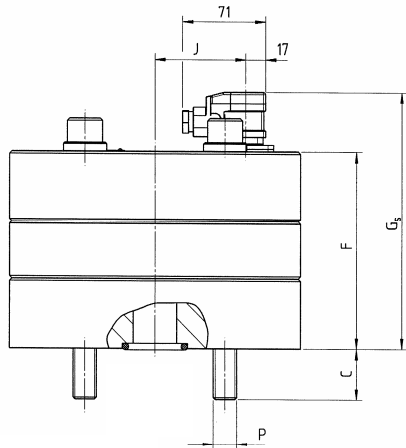

**Design S**

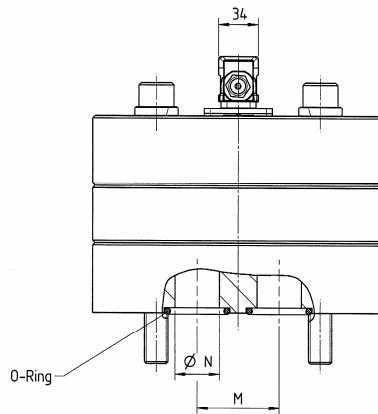

**Design H**

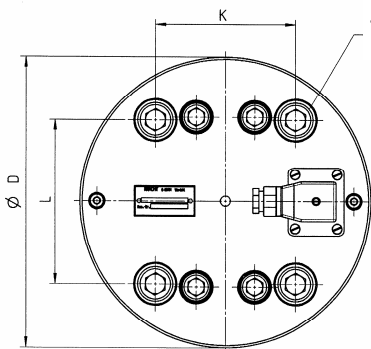

Tightening torque  $M_A$

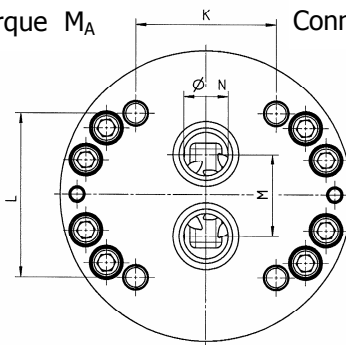

Connection dimensions

## Series 1, 2, 3, 4 and 7 - Connection Type P Version S, H with terminal boxes\*

Ordering code VC ... ..

Nominal size	Available Series	Weight kg	Tightening torque Nm	Dimensions											
				$M_A$	A	C	D	F	$G_S$	$G_H$	J	K	L	M	N
0,025	1, 7	1,8	14	85	10	60	50	87	99	-	70	40	20	6,5	M6
0,04	1, 7	2	14	85	9	60	56	93	105	-	70	40	20	6,7	M6
0,1	1, 7	2,3	14	85	10	60	65	102	114	-	70	40	20	6,7	M6
0,2	1, 2, 4, 7	2	14	85	13	60	57	94	106	-	70	40	20	9	M6
0,4	1, 4	3,7	35	100	17	90	63	100	112	-	80	38	34	16	M8
1	1,2,3,4,7	5,2	35	120	13	95	72	109	121	10,5	84	72	35	16	M8
3	1, 4	9	145	170	18	120	89	126	138	40,5	46	95	50	25	M12
5	1, 2, 3, 4, 7	13	145	170	22	120	105	142	154	40,5	46	95	50	25	M12

\* Version available with the code numbers: /55; /64; /102; /134 etc. (see type key p.6)

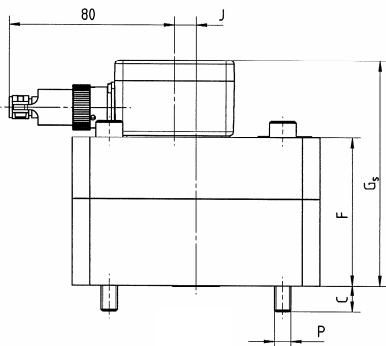

**Design S**

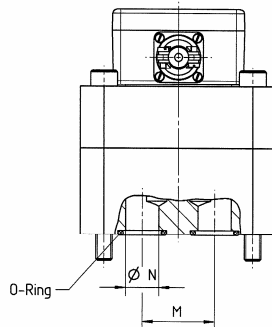

**Design H**

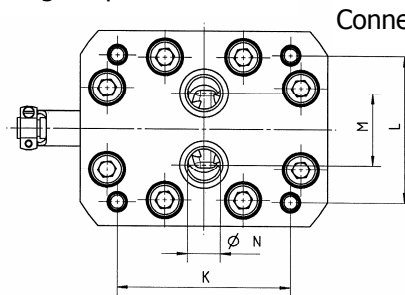
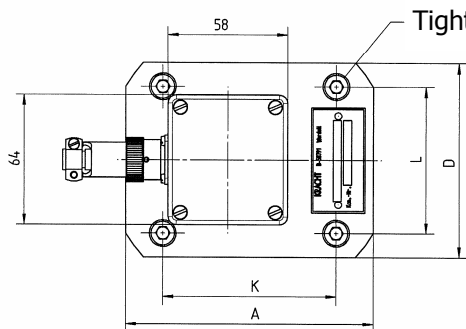

Connection dimensions

**Series 5, 6 and 8 – Connection Type P Version S, H**

Ordering code VC ... ..

Nominal size	Available Series	Weight kg	Tightening torque Nm	Dimensions										
				$M_A$	C	D	F	$G_S$	$G_H$	J	K	L	M	N
0,025	5, 6, 8	3	14	15	94	55	106	119	-	70	40	20	6,5	M6
0,04	6, 8	3,05	14	14	94	56	107	120	-	70	40	20	6,7	M6
0,1	6, 8	3,7	14	10	94	56	116	129	-	70	40	20	6,7	M6
0,2	5, 6, 8	3,1	14	13	94	57	108	121	-	70	40	20	9	M6
1	5, 6, 8	7	35	13	124	72	123	136	15,5	84	72	35	16	M8
3	5, 6	15,9	120	21	170	89	140	153	46,5	46	95	50	25	M12
5	5, 6	18,7	120	25	170	105	156	169	46,5	46	95	50	25	M12

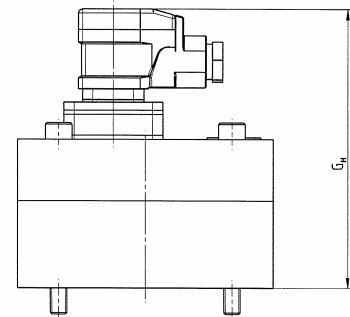
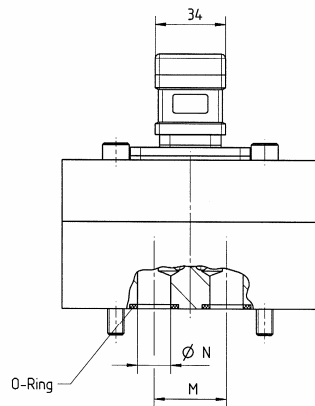
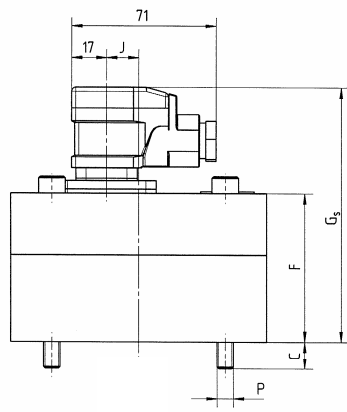

**Design S**

**Design H**

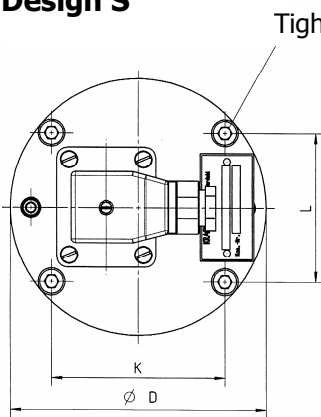

Tightening torque  $M_A$

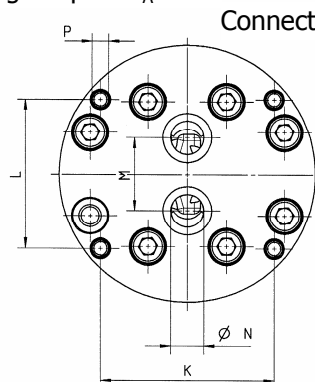

Connection dimensions

## Series 5, 6 and 8 – Connection Type P Version S, H with terminal boxes \*

Ordering code VC ... ..

Nominal size	Available Series	Weight kg	Tightening torque Nm	Dimensions										
				$M_A$	C	D	F	$G_S$	$G_H$	J	K	L	M	N
0,025	5, 6, 8	3	14	15	94	55	106	119	-	70	40	20	6,5	M6
0,04	6, 8	3,05	14	14	94	56	107	120	-	70	40	20	6,7	M6
0,1	6, 8	3,7	14	10	94	56	116	129	-	70	40	20	6,7	M6
0,2	5, 6, 8	3,1	14	13	94	57	108	121	-	70	40	20	9	M6
1	5, 6, 8	7	35	13	124	72	123	136	15,5	84	72	35	16	M8
3	5, 6	15,9	120	21	170	89	140	153	46,5	46	95	50	25	M12
5	5, 6	18,7	120	25	170	105	156	169	46,5	46	95	50	25	M12

\* Version available with the code numbers: /55; /64; /102; /134 etc. (see type key p.6)

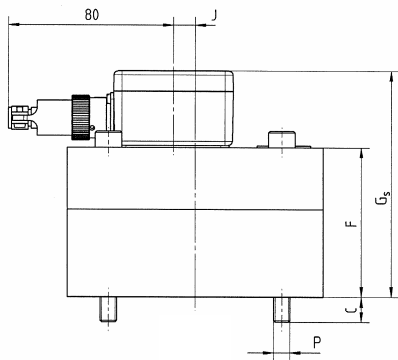

**Design S**

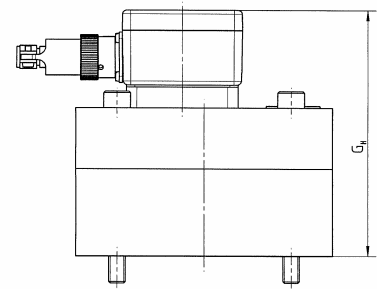
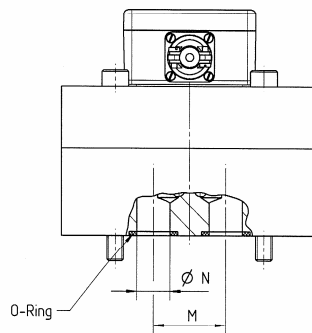

**Design H**

Tightening torque  $M_A$

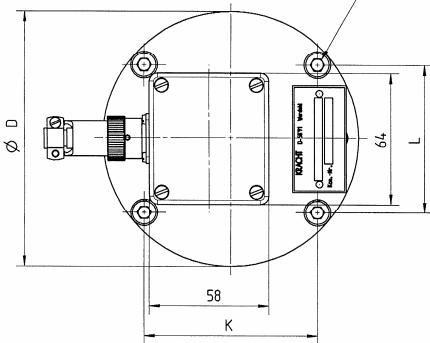

Connection dimensions

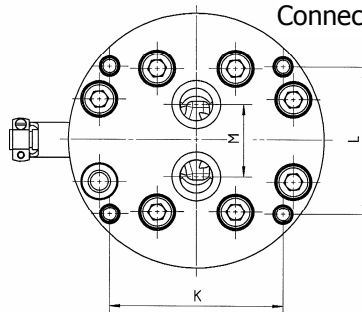

### Series 1 – Connection type P Version K

Ordering code VC .... ..

Nominal size	Available Series	Weight kg	Toghtening torque Nm	Dimensions										
				$M_A$	A	C	D	F	$G_K$	J	K	L	M	N
0,04	1	2	14	85	9	60	56	93	-	70	40	20	6,7	M6
0,2	1	2	14	85	13	60	57	94	-	70	40	20	9	M6
0,4	1	3,7	35	100	17	90	63	100	-	80	38	34	16	M8
1	1	5,2	35	120	13	95	72	109	10,5	84	72	35	16	M8
3	1	9	120	170	18	120	89	126	40	46	95	50	25	M12
5	1	13	120	170	22	120	105	142	40	46	95	50	25	M12

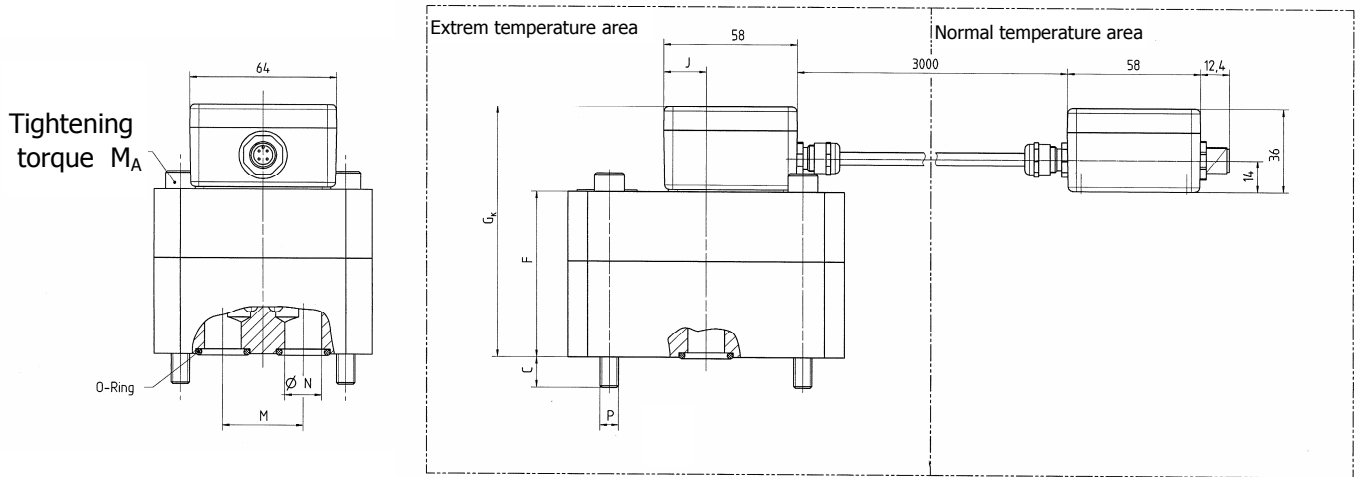

Connection dimensions

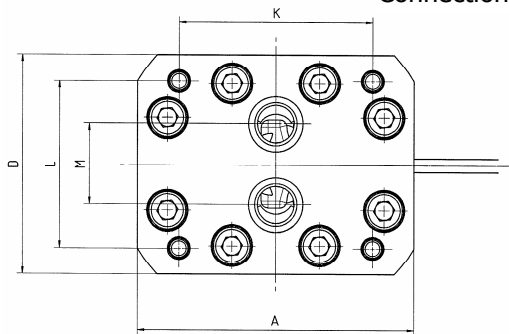

## Series 5, 6 and 8 – Connection Type R

Nominal size	Available Series	Weight kg	Dimensions												
			m	A	B	C	D	E	F	G <sub>S</sub>	G <sub>H</sub>	H	J	K	L
0,025	5, 6, 8	3	G 1/8	9	17	94	90	55	106	119	15	-	70	40	6,7
0,04	6, 8	3,05	G 1/4	13	21	94	90	56	107	120	15	-	70	40	6,7
0,1	6, 8	3,7	G 3/8	13	25	94	90	65	116	129	40	-	70	40	6,7
0,2	5, 6, 8	3,1	G 3/8	13	25	94	90	57	108	121	16	-	70	40	6,7
1	5, 6, 8	7	G 1/2	15	29	124	120	72	123	136	22	15,5	84	72	9
3	5, 6	15,9	G 1	19	42	170	162	89	140	153	30	46,5	46	50	13
5	5, 6	18,7	G 1	19	42	170	162	105	156	169	30	46,5	46	50	13

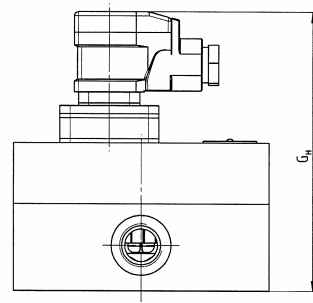
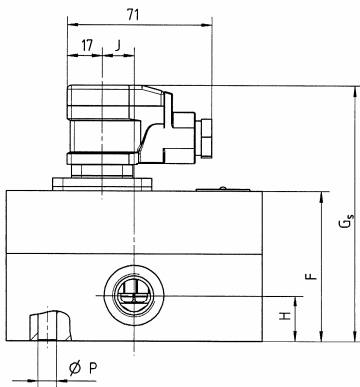

**Design S**

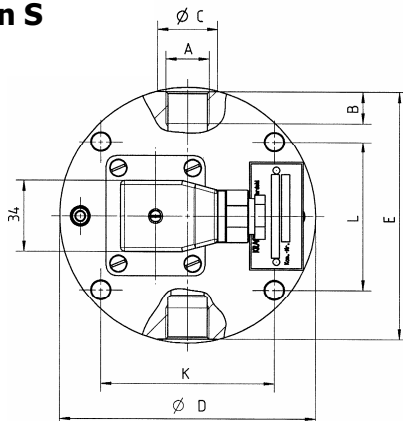

**Design H**

## Connection Plates

### With threaded connection, lateral

Ordering code	Weight kg	Dimensions																	
		m	A	B	C	E	F	G	H	J	K	L	M	N	P	R	c	d	e
<b>MVC 0,2 R 3 B 05*</b> Cast iron	1,8	85	90	35	65	76	7	11	7	70	40	20	6,5	M6/ t=14	17	0,7	25	G 3/8	13
<b>MVC 0,2 R 3 B 11*</b> Stainless steel	1,8	85	90	35	65	76	7	11	7	70	40	20	6,5	M6/ t=14	17	0,7	25	G 3/8	13
<b>MVC 0,4 R 1 C 09</b> Cast iron	2,7	100	110	37	86	96	7	11	7	80	38	34	16	M8/ t=18	18,5	0,7	29	G 1/2	15
<b>MVC 1 R 2 C 05</b> Cast iron	2,9	100	120	37	80	106	7	11	7	84	72	35	12	M8/ t=18	17,5	0,7	29	G 1/2	15
<b>MVC 5 R 2 E 05**</b> Cast iron	14	160	165	80	140	145	9	15	9	46	95	50	25	M12/ t=24	28	1	42	G 1	19
<b>MVC 10 R 2 G 05*</b> Cast iron	28	200	215	100	176	191	11	18	11	64	125	70	38	M16/ t=25	35	1	58	G 1 1/2	23

\* also suitable for VC 0.04 and VC 0.025

\*\* also suitable for VC 3

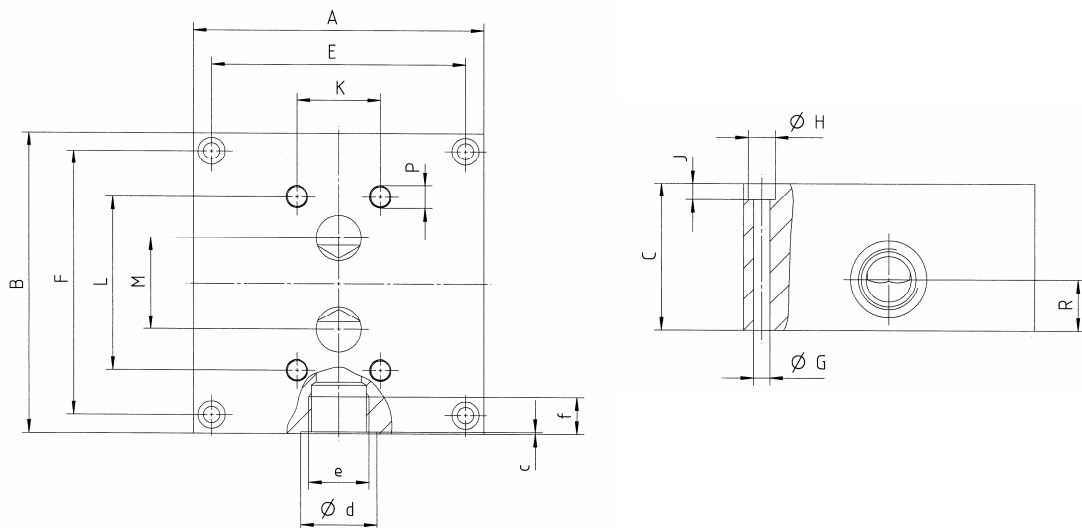

## With SAE flange connection, lateral

Ordering code	Weight kg	Dimensions																	
		m	A	B	C	E	F	G	H	J	K	L	M	N	P	R	a	b	e
<b>MVC 5 V 2 E 0,5**</b> Cast iron	14	160	165	80	140	145	9	15	9	46	95	50	25	M12/ t=24	40	57,2	27,8	25	M12/ t=24
<b>MVC 10 V 2 G 05</b> Cast iron	29	200	215	100	176	191	11	18	11	64	125	70	38	M16/ t=25	40	79,4	36,5	32	M16/ t=25

\*\* also suitable for VC 3

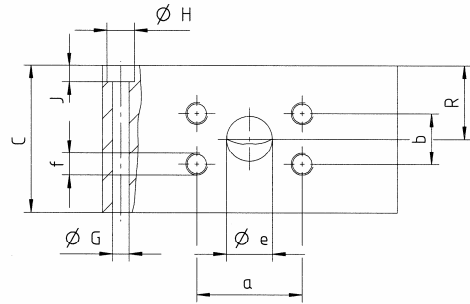
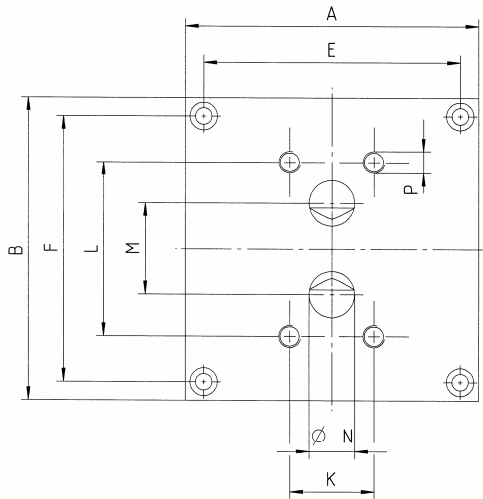

**With SAE flange connection, lateral**

Ordering code	Weight kg	Dimensions															
		m	A	B	C	E	F	G	K	L	M	N	P	R	a	b	e
<b>MVC 5 V1 E 09*</b> Cast iron	14,2	160	165	90	110	110	M8/ t=15	46	95	50	25	M12/ t=24	50	57,2	27,8	25	M12/ t=24
<b>MVC 12 V 1 G 09**</b> Cast iron	41,2	249	200	140	120	140	M20/ t=20	120	140	70	38	M20/ t=45	70	79,4	36,5	38	M12/ t=24

\* fits VC 3/79 and VC 5/79 (high pressure variant)

\*\* also suitable for VC 16

Connection dimensions

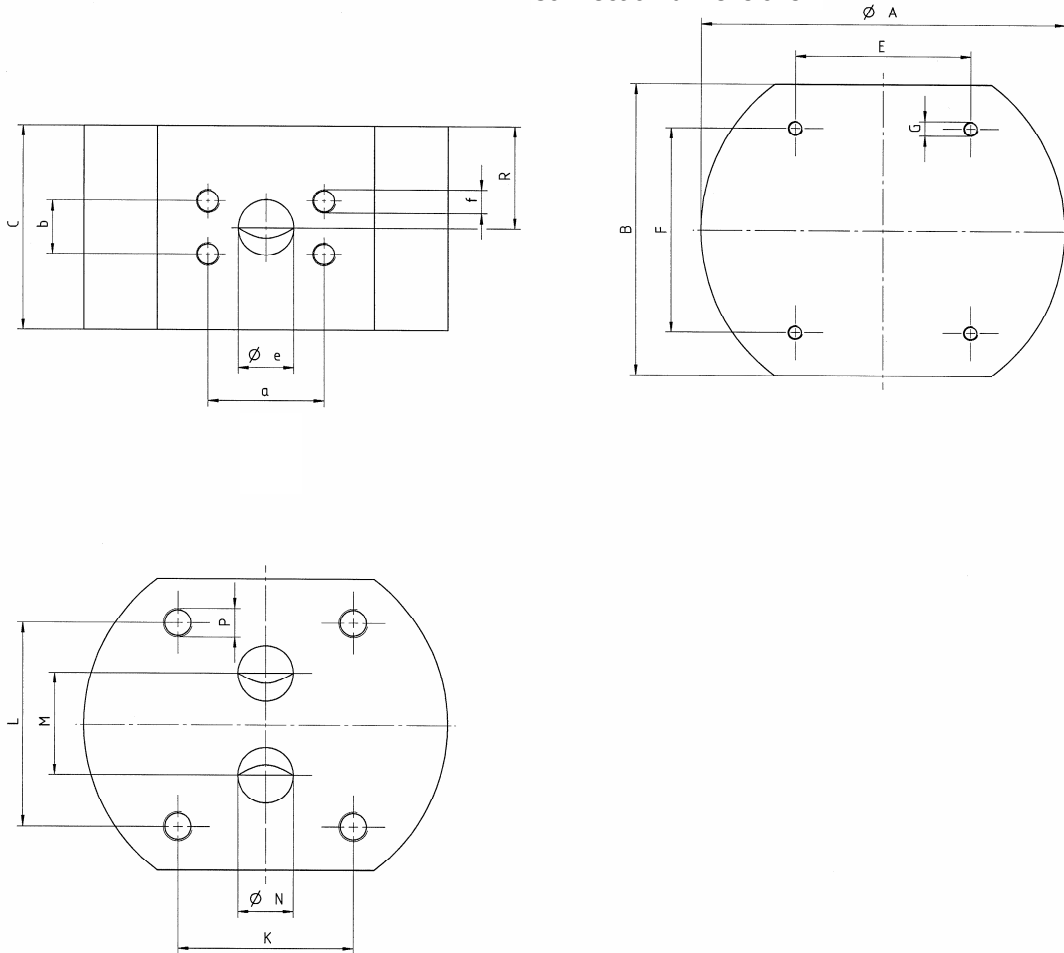

## With threaded connection, rear

Ordering code	Weight kg	Dimensions																		
		m	A	B	C	E	F	G	H	J	K	L	M	N	P	R	c	d	e	f
<b>MVC 0,2 R 3 B 04*</b> Cast iron	1,6	85	90	35	65	76	7	-	-	70	40	20	6,5	M6/ t=14	28	0,7	25	G 3/8	12	
<b>MVC 0,4 R 1 C 08</b> Cast iron	2,5	100	110	37	86	96	7	11	7	80	38	34	16	M8/ t=18	46	0,7	29	G 1/2	15	
<b>MVC 1 R 2 C 04</b> Cast iron	2,7	100	120	37	80	106	7	-	-	84	72	35	12	M8/ t=18	50	0,7	29	G 1/2	14	
<b>MVC 5 R 2 E 04**</b> Cast iron	9,6	160	165	55	140	145	9	15	9	46	95	50	25	M12/ t=24	55	1	42	G 1	18	
<b>MVC 10 R 2 G 04</b> Cast iron	15	200	215	55	176	191	11	18	11	64	125	70	38	M16/ t=25	72	1	58	G 1 1/2	22	

\* also suitable for VC 0.04 and VC 0.025

\*\* also suitable for VC 3

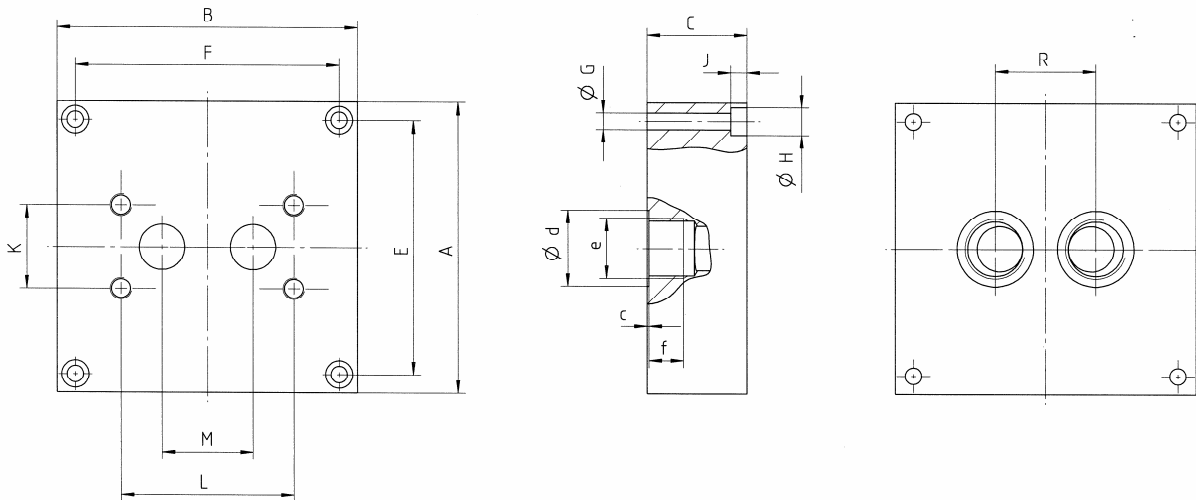

**With SAE flange connection, rear**

Ordering code	Weight kg	Dimensions																	
		m	A	B	C	E	F	G	H	J	K	L	M	N	P	R	a	b	e
<b>MVC 5 V 2 E 0,4**</b> Cast iron	9,5	160	165	55	140	145	9	15	9	46	95	50	25	M12/ t=24	80	57,2	27,8	25	M12/ t=24
<b>MVC 10 V 2 G 04</b> Cast iron	16	200	215	55	176	191	11	18	11	64	125	70	38	M16/ t=25	100	79,4	36,5	32	M16/ t=25

\*\* also suitable for VC 3

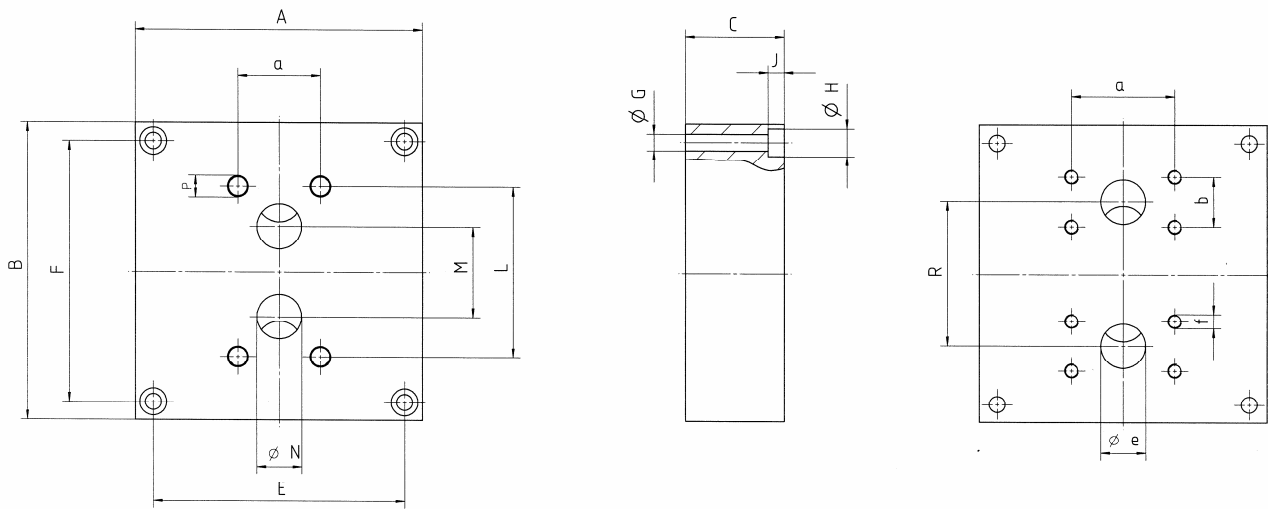

## Installation and Removal of the Volume Counter

Prior to delivery, the volume counter was inspected in the factory and is functional immediately following installation and connection of the electrical conduits.

The space required for the installed device is specified in the chapter, "Technical Data". The integrated measuring device should also be accessible for visual inspection without hazard at all times during operation.



**In the event of any damages to the volume counter, a pressure safeguard must be present in the system which prevents overstepping of the maximum permissible pressure of the volume sensor or other system components (pressure control valves).**

**It must be observed that the volume counter is only held by the housing during assembly and transport and never by the attached plug!**

## Corrosion Protection

All volume counters are inspected in the factory for their functionality with mineral hydraulic oil. Afterwards the connections are closed with a stopper so that the interior parts **are not** protected against corrosion for a longer period of time.

During transport and storage, the volume counters may not be exposed to any weather influences and significant temperature fluctuations, and they must be stored in dry conditions.

Should the volume counters be stored for a longer period of time, then they are to be treated in the interior and externally with a suitable corrosion protection oil. Furthermore, exposure of the volume counters to moisture is to be prevented with an absorbent medium.

Appropriate corrosion-preventative measures are to be undertaken if high humidity or an aggressive atmosphere is anticipated during transport.



**Preservatives used in preservation are to be examined for their compatibility with the materials and elastomers used in the volume counter. Furthermore, compatibility with the conveyance medium must be guaranteed.**

## Mechanical Installation

According to the connection type, the device is connected to the system either through a connection plate or by means of pipe threading located within the housing.



**Only connections and pipe conduits that are approved for the anticipated pressure area may be used. The regulations of the respective manufacturer must be observed!**

**The device must be installed in such way that it is not exposed to any impermissible vibrations.**

**Installation above hot parts is not permissible, as any possible fluids leaking could ignite.**

**The device must be inspected for leakages under operating conditions during start-up.**

## Plate Connection

- The conduit system must be adequately cleaned prior to assembly of the volume counter.
- Fasten the connection plate to its foreseen position in the system.



**Correct fit of the seals must be observed! The connection surface must be free of soiling and paint residue, etc.!**

- Set the housing onto the connection plate so that the bore holes are aligned with one another.

- Screw the housing to the connection plate.



**Tighten the VC / connection plate fastening screws crosswise. Observe the specified tightening torque in the process! For tightening torque, see "Dimensions and Weights", chart column "Tightening Torque" in the "Technical Data" chapter.**

- Inspect all connections of the system for impermeability following start-up.

### Mounting onto Extraneous Connection Plates or Valve Blocks

The following values for flatness and surface roughness are to be complied with for the mounting surface.

Nominal capacity*	0.025 ... 1	3 ... 5
Flatness $\mu\text{m}$	0.01	0.02
Surface Roughness $R_t$ $\mu\text{m}$	10	10

\* See model designation on device: VC...

Mounting of the volume counter must be conducted analogous to the above-described "Plate Connection".

### Pipe Connection

- The conduit system must be adequately cleaned prior to assembly of the volume counter.
- Connect the pipe conduits to the feed and exhaust of the measuring device. Observe the instructions of the respective manufacturer in this process.
- Pay attention in the installation that no sealing agent finds its way into the interior of the pipe conduit.



**The volume counter may not be deformed during assembly!**

- Inspect all connections of the system for impermeability following start-up.

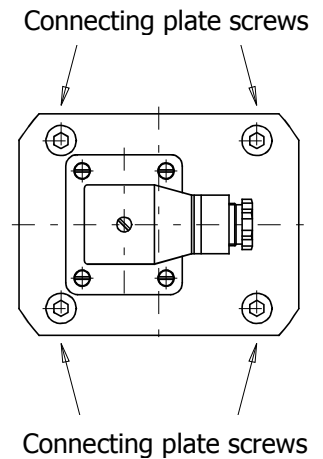

## Electrical Connection

### Electrical Data

Number of measurement channels	2
Rated voltage	$U_B = 24 \text{ V DC} \pm 20\%$ , protected against polarity reversal
Pulse amplitude	$U_A \geq 0.8 U_B$
Pulse wave shape with symmetrical output signal	Rectangle, Pulse-Duty Factor/Channel 1:1 $\pm 15\%$
Pulse offsetting between both channels	$90^\circ \pm 30^\circ$
Power requirement	$P_{b \text{ max}} = 0.9 \text{ W}$
Output performance / channel	$P_{a \text{ max}} = 0.3 \text{ W}$ , short circuit-proof
Normal protective system	IP 65 (DIN 40500)

Prerequisite: A 24V (DC) supply line ( $\pm 20\%$ ) must be provided for the preamplifier electricity supply.

- The electrical connections must be made in accordance with the circuitry plan illustrated below.



The plug may be pulled from the housing cover to connect the cables for more comfortable working.

The terminal configuration for Channel 1 or 2 influences the indicated rotation direction of the gearwheels, and therefore the polarity sign with which the measured volume current is displayed in the evaluation device.

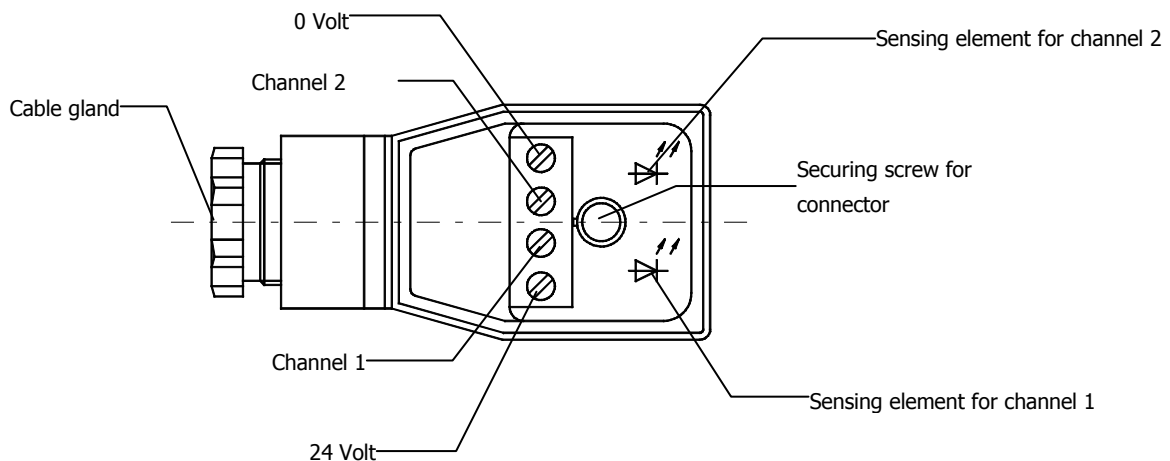

**Following completed assembly, the fastening screw (light) and the cable screw connection must be tightened.**

## Terminal box version

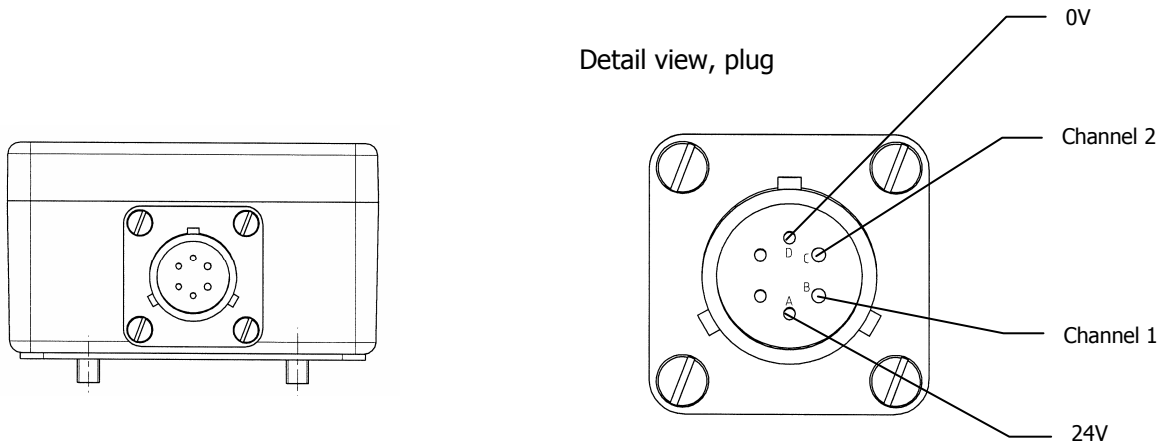

The plug contact in the terminal is equipped at the manufacturer in accordance with the pin assignment plan portrayed above.

The supplied counterplug must be accordingly connected by the customer.

The assignments for the terminals for Channels 1 and 2 have an influence on the gear's displayed direction of rotation and thus on the prefix with which the measured volume flow is displayed in the evaluation unit.

## Removal of the Volume Counter



**It must be ensured that the conduits have been de-pressurized and the electrical connection is free of voltage. The device and the conduits can still be filled with the conveyance medium or a cleaning agent. All regulations regarding handling of the medium last conveyed must be observed without exception! Sufficiently large collection containers must be provided. If necessary, sufficient ventilation of the workplace must be provided.**

- Loosen the fastening screw on the plug.
- Pull the plug out of the housing.
- *Plate Connection:* Remove the screws fastening the volume counter to the plate.
- *Pipe Connection:* Disengage the pipe conduit connections from the housing, and if necessary dismantle the housing from the holder.



**In the event of hardening mediums, clean the volume counter as quickly as possible with a suitable cleaning agent!**

## Operation



**The volume counter may only be used within the specified limiting values (for values, see chapter, "Technical Data").**

**It must be assured that the medium to be measured does not corrode the materials of the volume counter (see "Overview Series and Materials"). The medium may not contain any abrasive particles. If in doubt, consult the manufacturer.**

**The volume counter is designed for operation with fluids. Dry operation is not permissible.**

Prior to delivery, the volume counter was inspected in the factory. It can be set into operation as soon as the mechanical and electrical connections have been made. During operation, both LED displays illuminate in the VC plug as long as a continuous fluid current flows through the meter. Measures to be taken in the event of disruption can be read in the chapter, "Recognizing and Eliminating Disruptions". In the event of an unplanned breakdown of the counter signal, the system must be shut down immediately.

## Permissible Limiting Values for Operation



**The flow resistance of  $\Delta p$  may not exceed 16 bar, since this leads to mechanical damages.**

The limiting values specified in Technical Data for the environmental conditions must be complied with.

## Maintenance

Volume counters are fundamentally maintenance-free. If however fluids are conveyed that can lead to deposits in the measuring device, then cleaning of the device can be required. Otherwise, the device can be cleaned within the framework of normal system cleaning. An indication of wear can be a change in the measurement precision. The customer is recommended to inspect this on a regular basis.



**In the event of hardening mediums, clean the volume counter as quickly as possible with a suitable cleaning agent.**

Check the fastening screws regularly for a firm fit and retighten them if necessary (observe the screw tightening moment, see chapter, "Installing and Removing the Volume Counter").



**The connecting leads must be depressurized for all work on the device and before it is removed.**

**The static seals at the mould seals of the volume counter must be inspected for impermeability on a regular basis.**

## Cleaning

**Devices from Series 1, 2, 6, 7 and 8:** Never open these devices yourself, since they can only be reassembled in working order by a specialist.

**Devices from Series 3, 4 and 5:** With appropriate care, these can be opened and cleaned.



**It must be ensured that the conduits have been depressurized and the electrical connection is free of voltage. The device and the conduits can still be filled with the conveyance medium or a cleaning agent. All regulations regarding handling of the medium last conveyed must be observed without exception! Sufficiently large collection containers must be provided. If necessary, sufficient ventilation of the workplace must be provided.**

- Remove the volume counter (see chapter, "Installation and Removal of the Volume Counter").
- Empty the measuring device.
- Loosen the fastening screws holding together the two halves of the housing.  
The hexagonal Allen screws (4 or 8) are accessible from the underside of the housing.



**No screwdrivers or similar tools may be used for prying in the mould seams of the upper part of the volume counter.**

**The gearwheels may not be removed from the housing with pliers.**

- Clean with interior of the housing, the gearwheels and the bearings with a suitable cleaning agent.



**In the event of mechanical damages in the interior to the housing or the gearwheels, then the en-**

tire device must be sent to the manufacturer for repair.

- Insert both gearwheels with bearings into the lower part of the housing.
- Insert the O-ring into the housing groove.
- Position the upper part of the housing onto its lower part (use alignment pins).
- Firmly tighten all screws crosswise that hold the housing together with the specified tightening moment (see below).



**All parts must be free of dirt for assembly. It must be assured that no foreign particles remain in the interior of the volume counter from assembly.**

### Housing Connection Tightening Torque, Series 3, 4 and 5

Nominal capacity*	0.025	0.04	0.2	0.4	1	3	5
<b>Tightening Moment    Nm</b>	40	40	40	65	65	145	145

\* See model designation on device: VC...

- Reassemble the housing into the system as described in the chapter, Installation and Removal of the Volume Counter.

### Recognizing and Eliminating Disruptions

In the event that the volume counter does not work properly, then the electrical components should be examined first.

The measuring device must remain in operation for this.



**This work may only be conducted by qualified electricians.**

If there is no analytical evaluation software, then defect analysis should proceed according to the following Defect Search Chart.

### Return

The device must be appropriately packed in the event of repair or inspection at the manufacturer factory. Furthermore, a safety specification sheet on the medium used must accompany the device. In the case of recognized mineral oils, at least the precise type designation is required.

The device must be rinsed out in the event of hardening or adhesive mediums.

## Disposal

The disposal of the packaging and the used parts must be conducted in accordance with the provisions of the country in which the device is installed.

Defect	Possible Cause	Elimination
Both LED displays on the disconnection switch amplifier are lighting, but displaying incorrect values.	The connection between the volume counter and the evaluation device is disrupted.	Inspect the connection and replace the cable or plug is necessary.
One LED display is not lighting during operation.	The wiring between the sensor and circuit board or between individual soldering joints and the circuit board are damaged.	Send the measuring device to the manufacturer for repair.
	The affiliated sensor is defective.	
Both LED displays are not lighting during operation.	Electricity supply breakdown	Examine the mains cable and fuses.
	Since it is improbable that both sensors break down, it is to be assumed that the meter is stuck.	<b>Shut down operation of the volume counter immediately!</b> Send devices from the Series 1, 2, 6, 7 and 8 to the manufacturer for repair. Devices from Series 3, 4 and 5 can be dismantled and cleaned (see chapter, "Maintenance").
Leakage, medium leaks	Leaky o-ring in the housing.	Send devices from the Series 1, 2, 6, 7 and 8 to the manufacturer for repair and consult with the manufacturer. Inspect devices from Series 3, 4 and 5 for seal compatibility, consult the manufacturer if necessary and install a new set of seals (purchase from manufacturer).
	The O-ring between the volume counter and the connection plate is leaky.	Inspect for seal compatibility, install new O-rings.
Decline in measuring precision	Wear	Inspect the measuring device or send it to the manufacturer for repair.