

KRACHT

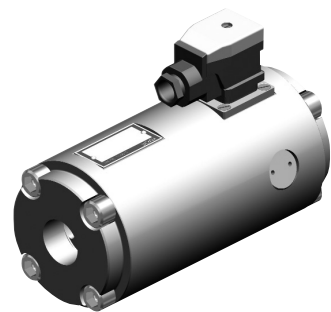

Screw-Type Flow Meter

SVC

Description

Screw-type flow meters belong to the group of positive displacement flow meters. Two measuring spindles (pos. 2) with a screw-shaped profile engage with each other. They are low-friction mounted using roller contact bearings (pos. 3) and enclosed by a housing (pos. 1). The liquid flow causes the spindles to rotate and passes through the device in an axial direction. In so doing, self-contained part volumes are formed which are continuously filled and emptied. This principle of measurement causes no pressure and/or flow pulsations.

A sensing wheel attached to the measuring spindle (pos. 4) is scanned by two non-contact sensors. Using two sensors, a bidirectional flow with detection of flow-direction is possible. The inflow and outflow occurs almost without deflection. Consequently, the device exhibits a relatively low drop in pressure. Measuring this way does not require the flow to be calmed at the inlet and outlet. All moving parts are lubricated by the measurement medium.

Construction

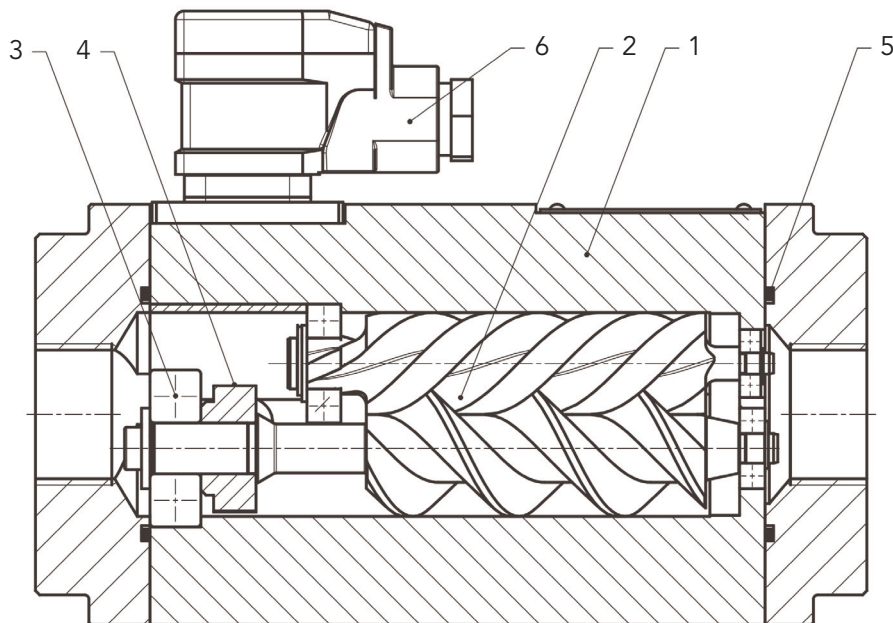

- | | |
|-------------------------------------|-----------------------------|
| 1 Housing | 4 Sensing wheel and sensors |
| 2 Measuring system (screw spindles) | 5 Seal (O-ring) |
| 3 Bearing (roller contact bearing) | 6 Connection |

Product Characteristics

- Very low pressure drop
- High-response measurement
- High working pressure
- Very low noise emission
- Measurement independent of viscosity within the specified ranges
- High-precision measurement with outstanding reproducibility
- Temperature-independent output signals over a wide temperature range
- High degree of accuracy, even with low flow rates at the bottom end of the measuring range
- High operating reliability of the electronics
- Easy to use terminal of the preamplifier
- Operating indication of the electronic
- Sensor system and preamplifier in EMC-compatible design
- Explosion-proof version available

Accuracy Characteristics

The accuracy figures quoted by KRACHT refer to the impulse volume [cm³/Imp], that is to say the percentage deviation applies to the current value in each case.

The linearity error over the entire measuring range is $\leq \pm 0.1\%$.

From a viscosity of 20 mm²/s amounts the accuracy $\leq \pm 0.2\%$ about the whole measuring range of 1 : 150.

Accuracy checking forms part of quality inspection in every case.

On request the result of the test will be documented in the form of an accuracy characteristic curve; an example relating to a SVC 10 A1 is given below.

The accuracy values quoted by Kracht are confirmed by the DKD (German Calibration Service).

Accuracy

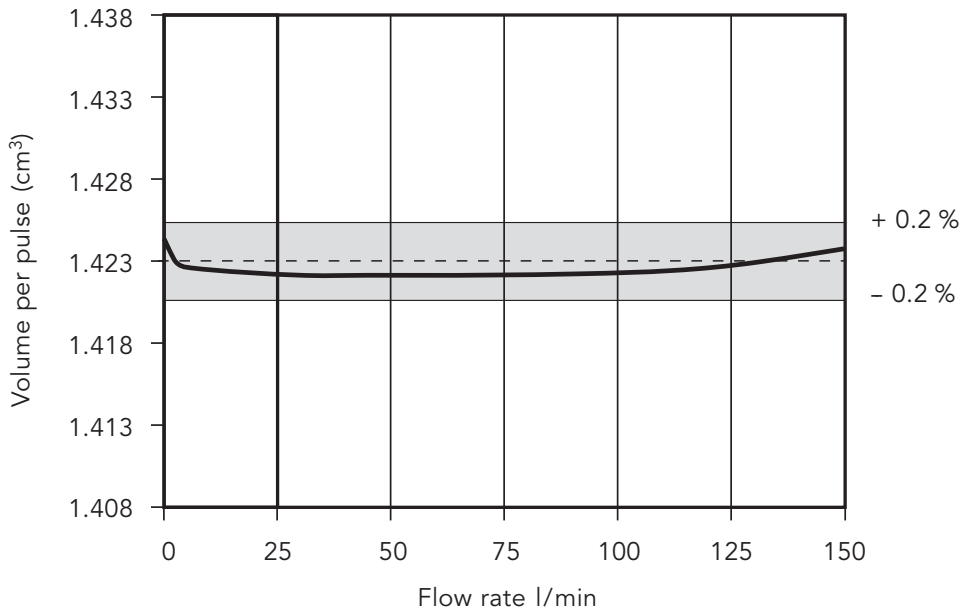

Linearity

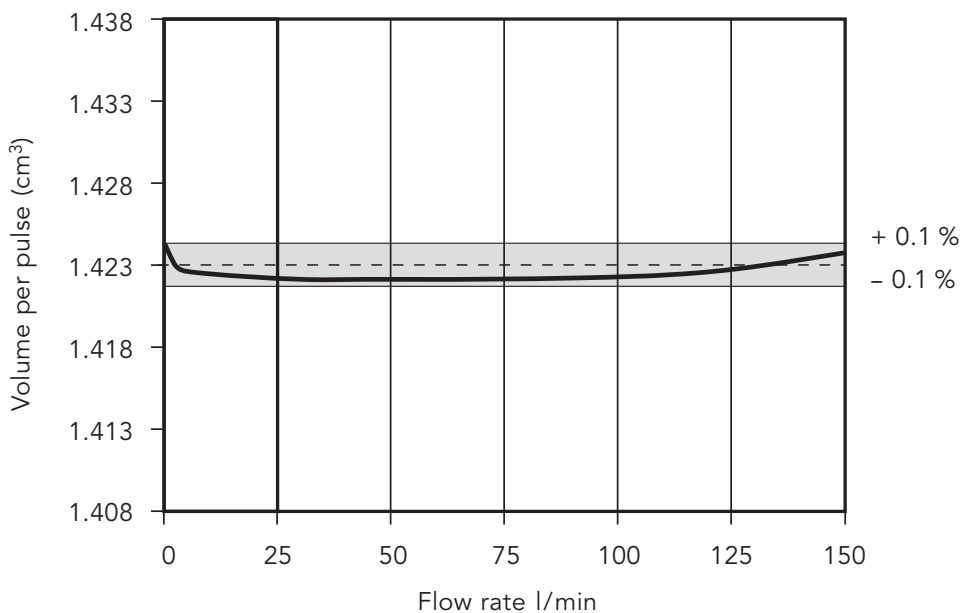

Materials

Housing and flanges	EN-GJS-400-15 (GGG-40)
Measuring spindles	Heat-treated steel
Roller contact bearing	Heat-treated steel
O-ring	NBR, FKM, EPDM, FEP (other sealing materials on request)

Characteristics

Mounting position	optional
Flow direction	optional
Connection type	Pipe thread, SAE-flange
Working pressure SVC 10 SVC 40	p_{max} = 250 bar p_{max} = 200 bar
Max. pressure drop	Δp_{max} = 25 bar
Viscosity	1 ... 1.000.000 mm ² /s (depending on the flow)

Permitted temperature ranges

Sealing Materials	NBR	FKM	EPDM	FEP
Ambient temperature	-30 °C ... 80 °C	-15 °C ... 80 °C	-30 °C ... 80 °C	-30 °C ... 80 °C
Media temperatures:				
Standard version	-30 °C ... 100 °C	-15 °C ... 120 °C	-30 °C ... 120 °C	-30 °C ... 120 °C
High temperature version	n. a.	-15 °C ... 150 °C	n. a.	-30 °C ... 150 °C
☒-version	-30 °C ... 80 °C	-15 °C ... 80 °C	-30 °C ... 80 °C	-30 °C ... 80 °C

Working Characteristics

Nominal size	Impulse volume	Resolution (K-factor)	Resolution (K-factor) 4-fold*	Measuring chamber volume	Pulse rate at Q_{nenn}	Measuring range
	cm ³ /Imp	Imp/l	Imp/l	cm ³ /U	Hz	l/min
10	1.423	702.7	2811.0	27.04	2342	1.0 ... 150
40	5.150	194.2	776.7	123.6	2589	4.0 ... 600

* Resolution with 4-fold Evaluation of both measuring canals

Type Key

Ordering example

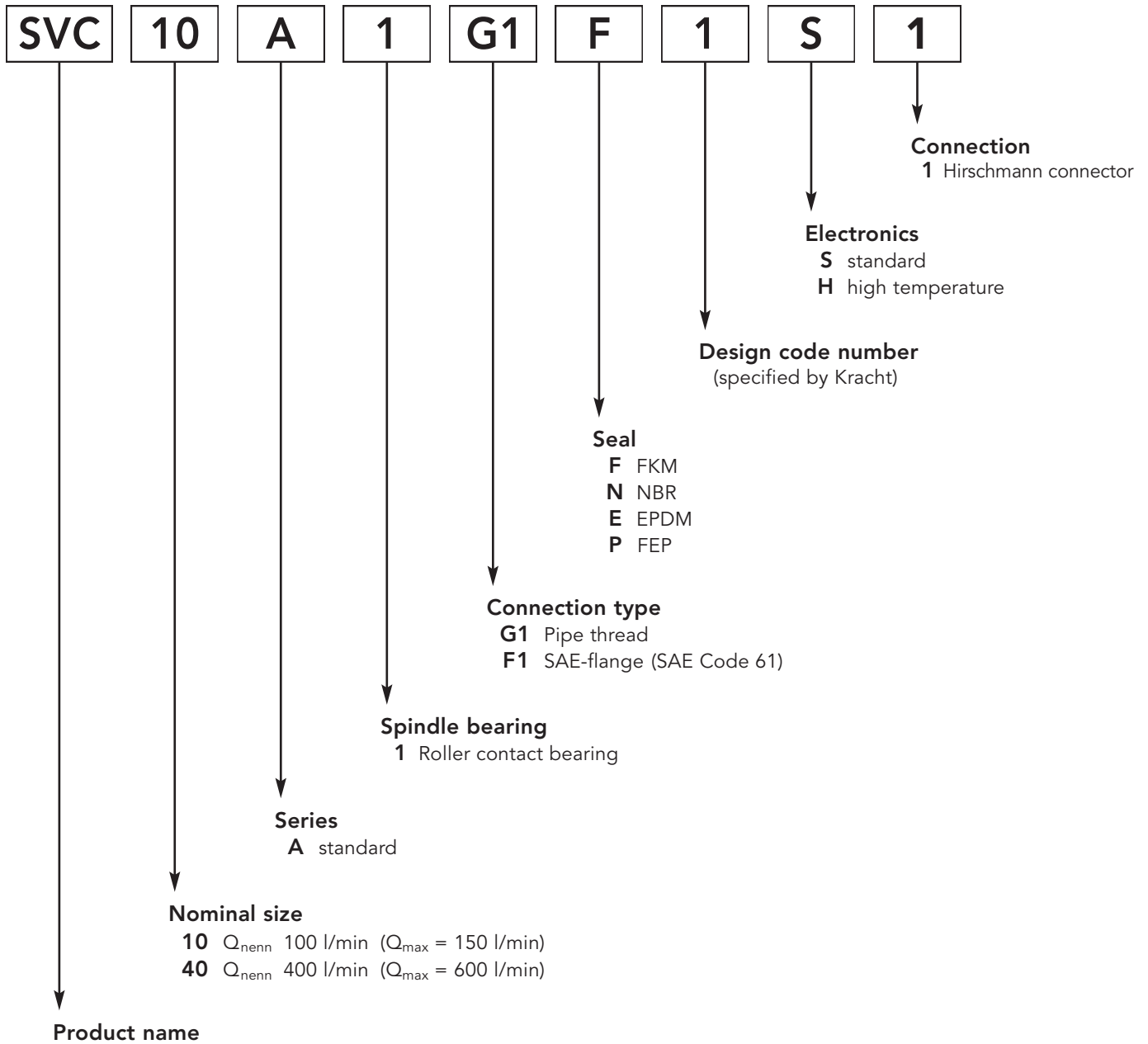

Electrical Connection

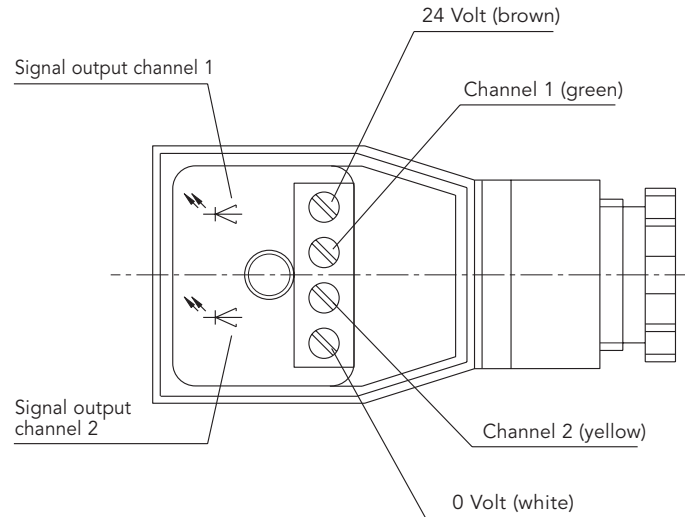

Electrical Characteristics

Number of measuring channels	2	Pulse offset between two channels	$90^\circ \pm 30^\circ$
Operating voltage	$U_{op} = 12 \dots 30$ VDC polarized	Power requirement	$P_{bmax} = 0.9$ W
Pulse amplitude	$U_A \geq 0.8 U_B$	Output power/channel	$P_{amax} = 0.3$ W short-circuit-proof
Pulse shape with symm. output signal	square wave pulse duty factor/channel $1:1 \pm 15\%$	Degree of protection	IP 65 DIN 40050
Signal output	PNP (NPN on request)		

Signal Characteristics

Channel I

- A rising edge
- B one pulse (corr. to flow rate of geom. tooth volume V_{gz})
- C falling edge
- D ON phase
- E OFF phase
- F pulse duty factor $1:1 \pm 15\%$

Channel II

- G channel offset
- H flow direction 1
- K reversal of flow direction
- J flow direction 2

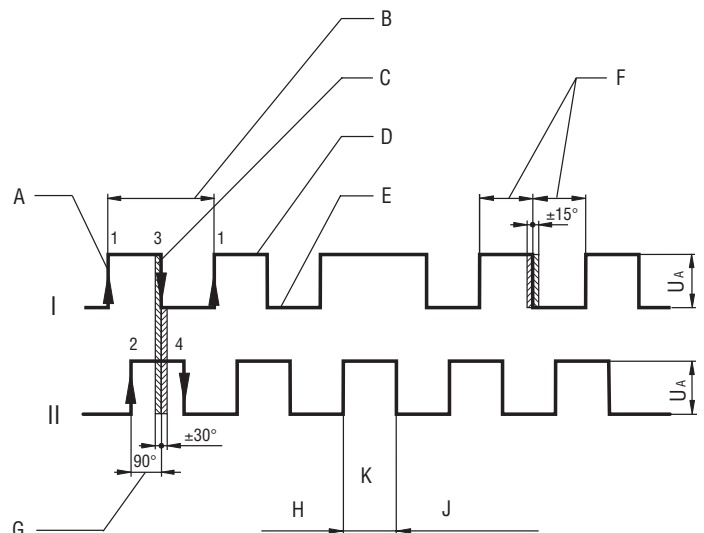

Pressure Drop Parameter: Viscosity (mm²/s)

SVC 10 A1

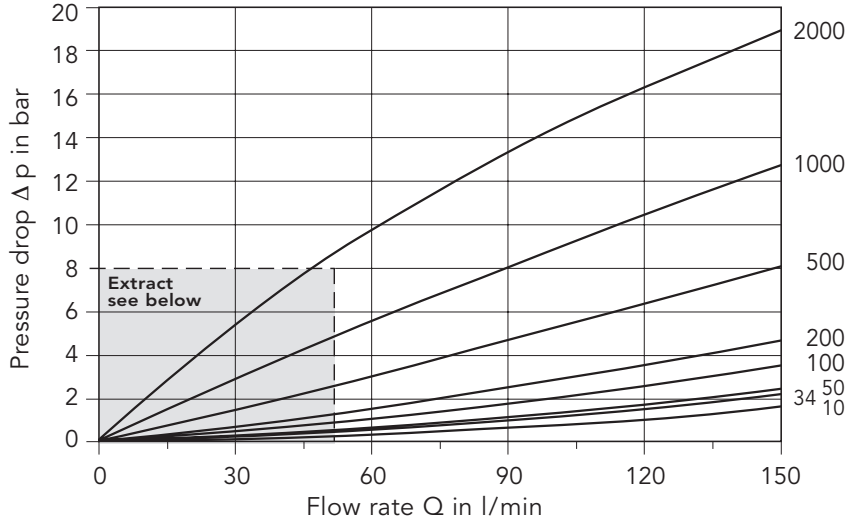

SVC 10 A1 (■ extract)

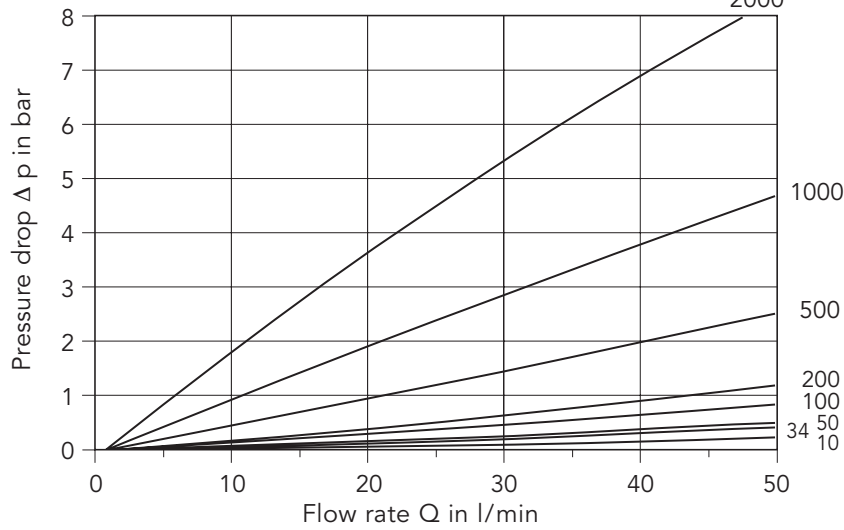

SVC 40 A1

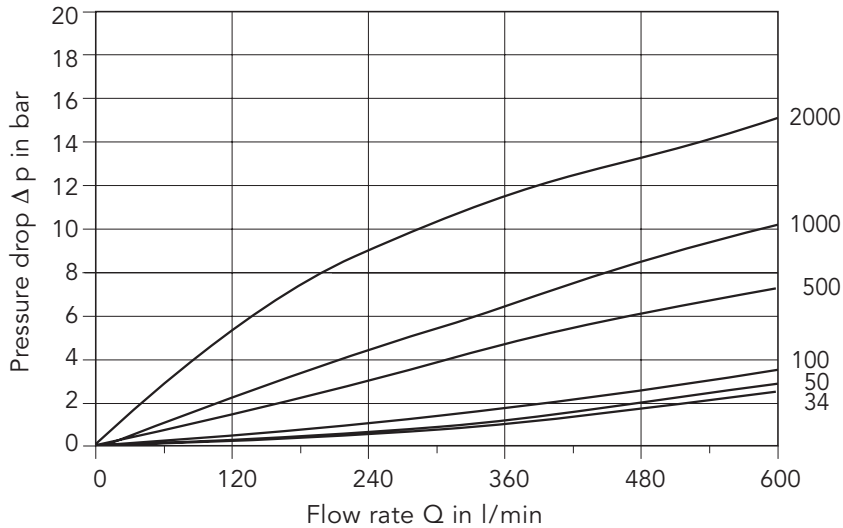

Dimensions SVC 10 (in mm)

Connection – Pipe thread (SVC 10 A1 G1)

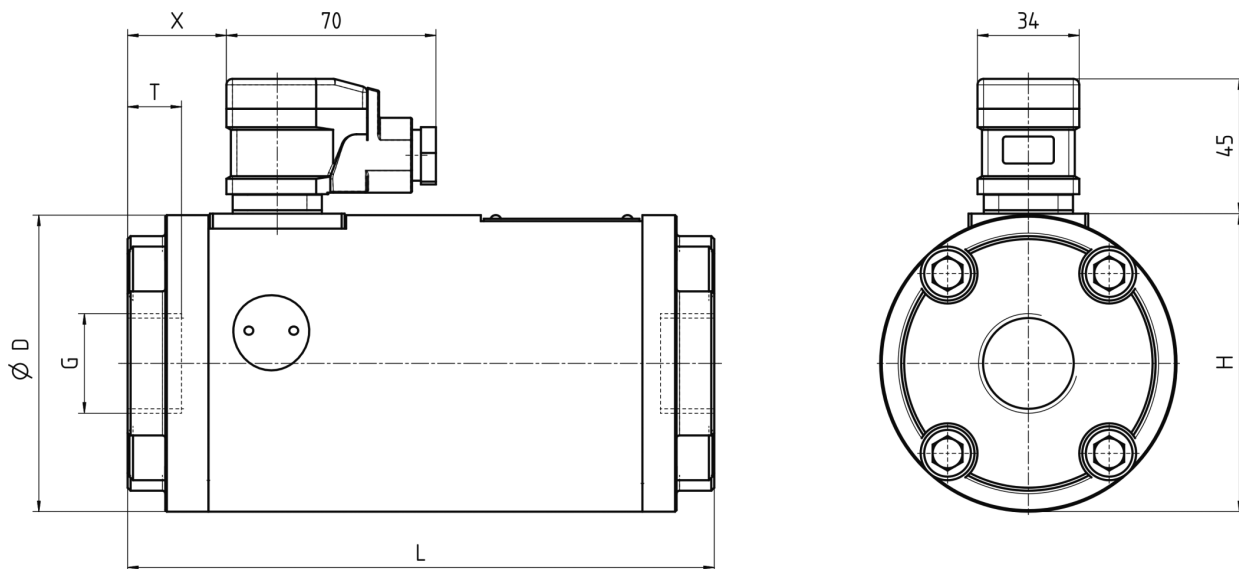

Connection – SAE-flange (Code 61) (SVC 10 A1 F1)

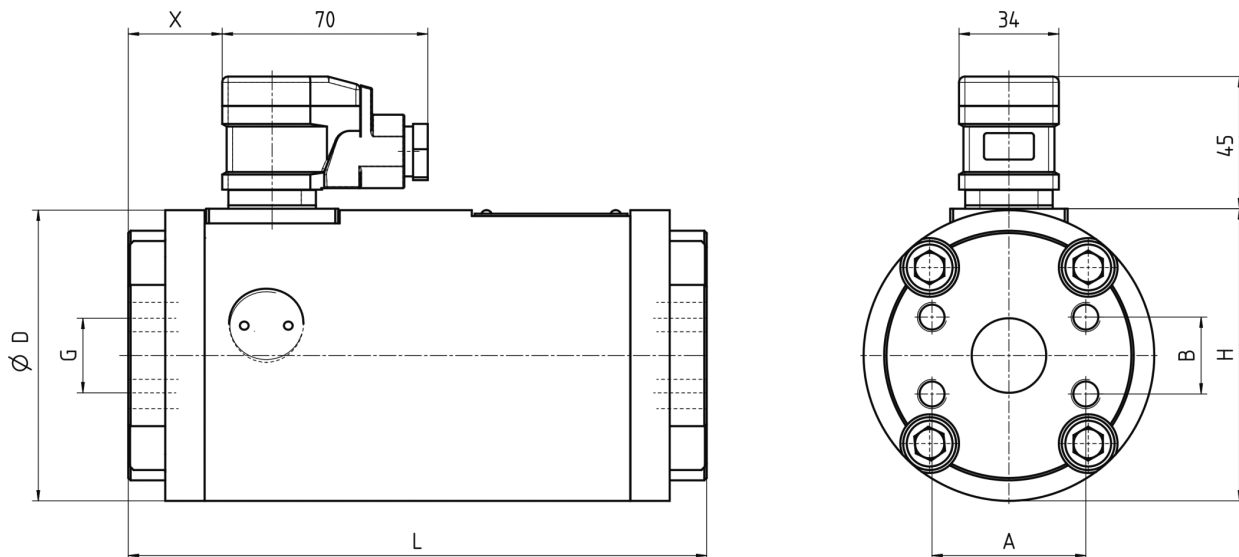

Nominal size	A	B	D	L	H	G	T	X	Weight kg
10 A1 G1	-	-	99	196	100	1"	19	33	9.6
10 A1 F1	52.4	26.2	99	197	100	25	-	32	9.6

Dimensions SVC 40 (in mm)

Connection – Pipe thread (SVC 40 A1 G1)

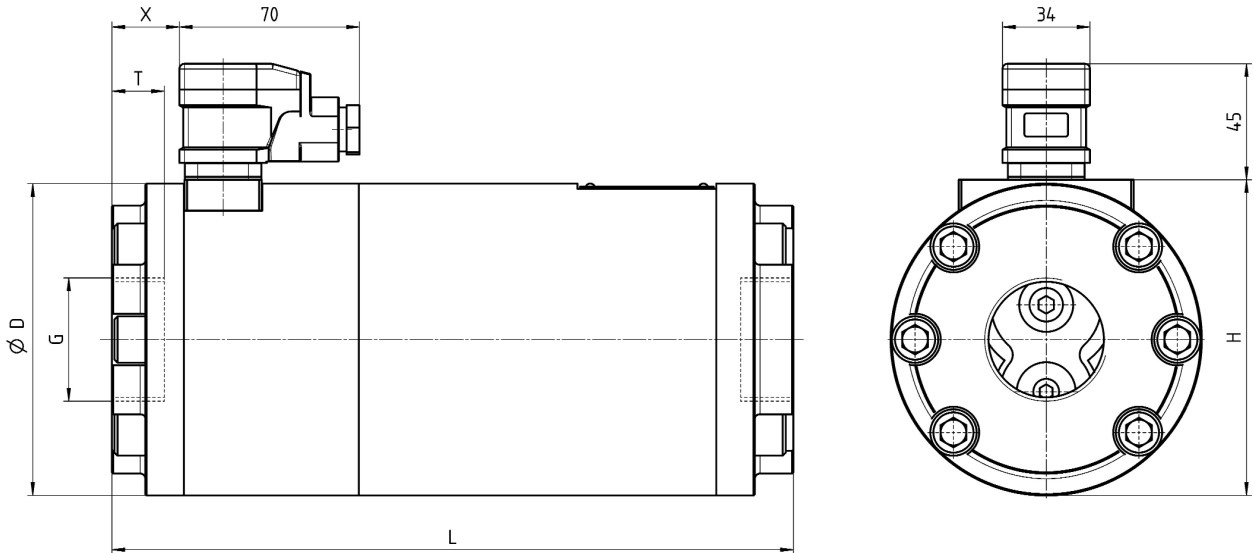

Connection – SAE-flange (Code 61) (SVC 40 A1 F1)

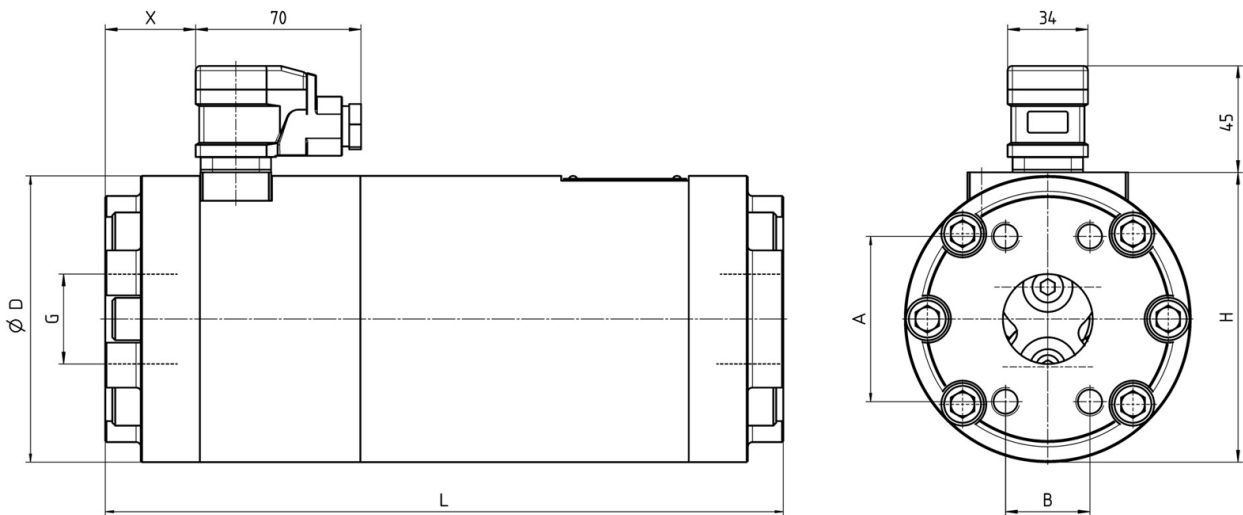

Nominal size	A	B	D	L	H	G	T	X	Weight kg
40 A1 G1	–	–	121	265	122.5	1½"	23	26	17.15
40 A1 F1	69.9	35.7	–	287	–	38	-	38	17.90

Product Portfolio

Transfer Pumps

Transfer pumps for lubricating oil supply equipment, low pressure filling and feed systems, dosing and mixing systems.

Mobile Hydraulics

Single and multistage high pressure gear pumps, hydraulic motors and valves for construction machinery, vehicle-mounted machines.

Flow Measurement

Gear and turbine flow meters and electronics for volume and flow metering technology in hydraulics, processing and laquering technology.

Industrial Hydraulics / Test Bench Construction

Cetop directional control and proportional valves, hydraulic cylinders, pressure, quantity and stop valves for pipe and slab construction, hydraulic accessories for industrial hydraulics (mobile and stationary use).

Technology Test benches / Fluid Test benches.



SVC/GB/01.10

KRACHT