

# AS 8 Operation Manual

Software version: DOS

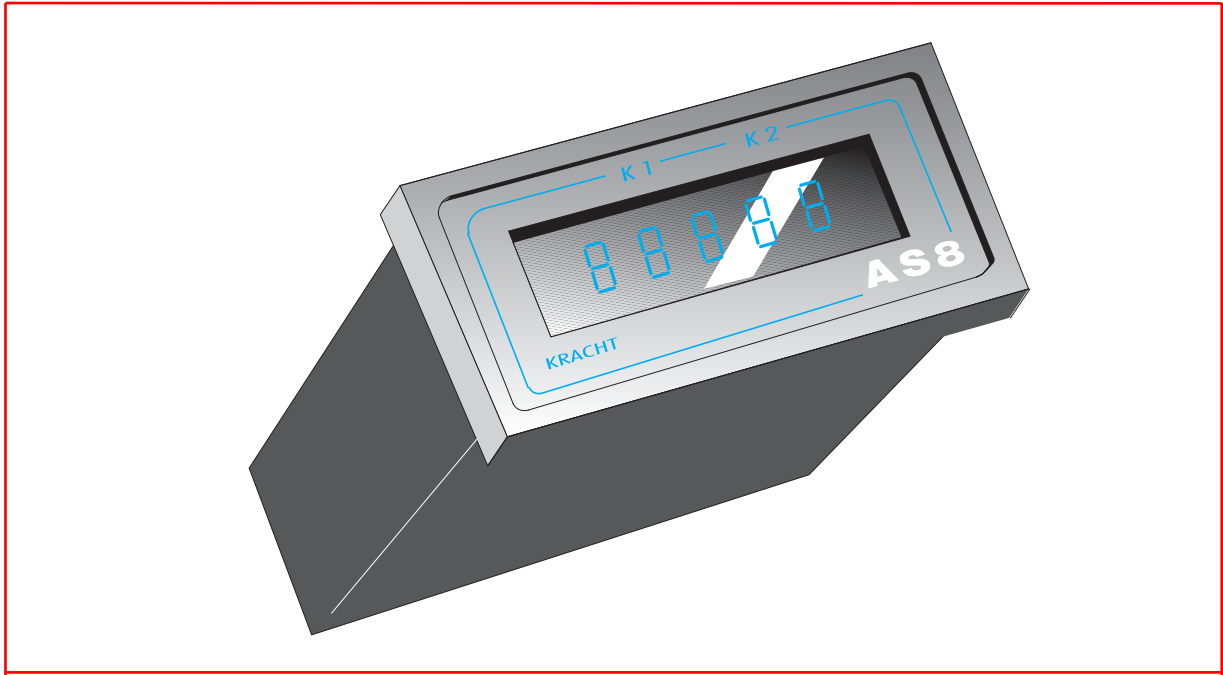

**KRACHT**  
Volutronic®

<b>1. SAFETY</b>	<b>3</b>
<b>2. DESCRIPTION</b>	<b>4</b>
2.1 How are the batching quantities programmed?	5
2.2 How is the filling process started?	6
2.3 What failure display does the instrument offer?	7
2.4 Automatic Overflow Correction	7
2.5 How are faulty dosages monitored?	7
<b>3. CONNECTING THE AS8</b>	<b>8</b>
3.1 Connecting the voltage supply	8
3.2 Connecting the volume counter	9
3.3 Connecting the relay contacts	10
<b>4. AS8 PROGRAMMING</b>	<b>11</b>
4.1 Overview of the input values	12
4.2 What must be programmed when connecting a volume counter?	13
4.3 Which display parameters can be represented (DIP switches) ?	14
<b>5. TECHNICAL DATA</b>	<b>15</b>
<b>6. TYPE CODE</b>	<b>16</b>
<b>7. CONNECTIONS</b>	<b>17</b>
<b>8. SETTING THE SUPPLY VOLTAGE</b>	<b>18</b>
<b>9. DIMENSIONS</b>	<b>19</b>
<b>10. AS8 AS 19“ RACK UNIT</b>	<b>20</b>

## 1. Safety



The safety notes included in these operating instructions are indicated by this 'attention-getter' symbol.

If the text accompanying this symbol is not heeded, danger to personnel or equipment may result.



Other instructions, which are not safety warnings, but which give advice on optimum operation, are indicated by a hand.

### **General safety instructions**

The electronic AS8 is constructed to the latest standards in technology. The AS8 should be operated only

- in technically sound condition,
- as instructed,
- with awareness of the safety precautions, following these operating instructions.

The AS8 must only be operated as an item of equipment installed in an internal area.

The AS8 must only be operated in the prescribed condition.

The stated limiting values (see also section on "Technical Data") must, under no circumstances, be exceeded.

Personnel engaged in the installation, operation and maintenance of the AS8 must be appropriately qualified. This qualification can be obtained by appropriate training or instruction. Such personnel must be familiar with the contents of these operating instructions.



During all operations the relevant national regulations relating to safety precautions in the work place and where applicable, internal regulations of the operator must be observed, even if these are not detailed in these operating instructions.



The AS8 must not be operated in hazardous areas, nor in areas where medical apparatus is in use, nor in areas which are expressly named in VDE 0411 Part 100.



If the AS8 is used for the control of machines or sequential processes where damage to the machine or accident to operating personnel is possible as a consequence of failure or faulty operation of the AS8, then appropriate safety precautions must be implemented.

In the case of variations (including those relating to operating behaviour), which prejudice safety, the AS8 must be switched off immediately.



During installation work on the AS8, the power supply must always be disconnected. Installation work must only be carried out by appropriately qualified personnel.



## 2. Description

The AS8 dosing version is especially designed for employment in dosing lines. It allows of one volume counter to be connected.

The units are usually operated in conjunction with KRACHT volume counters. However, other measuring systems with incremental signals can be connected. These may, for example, be oval wheel meters or angle of rotation sensors.

Programming and adjustments are achieved by three keys. The input values are arranged in menus.

The integrated 24 V DC sensor supply enables direct connection to the volume counter.

The measuring devices in the AS8 series are obtainable as built-in control panel devices, as desk-top units, or as 19" rack-mounted units.

### ***Manufacturers address:***

KRACHT GmbH  
Gewerbestraße 20  
58791 Werdohl

Tel. 02392 / 935-0  
Fax 02392 / 935209

## 2.1 How are the batching quantities programmed?

6 dosages (programmes) can be stored in the AS8. Specific dosages are called up via the foil keyboard.

Obviously dosage quantities must firstly be entered under the menu code **02** to **07** for dosage values 1 to 6, before they can be called up. (See para. **4.0** and **4.1**)

Press key **F1** for about 2 seconds

The display shows the last chosen dosage value

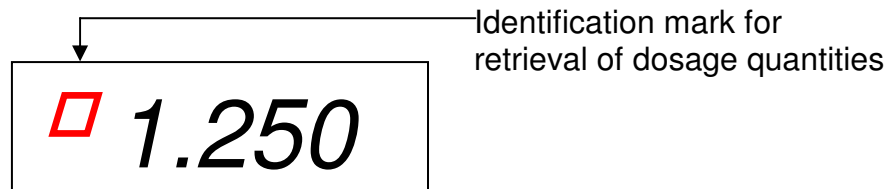

To show that the programme can be retrieved the rectangle in the upper part of the first segment flashes.

The different dosages can be displayed by pressing key **F3** .

The last displayed dosage value is set by pressing **F1** once more.

## 2.2 How is the filling process started?

Connect the digital input *Stop* (terminal 13) to 24 Volt.

The filling process is started by the digital input *Start* (terminal 12, connected to 24 Volt ) The AS8 resets the last dosage quantity and switches the dosage valve (*RELAY VALVE terminal 5*)

After completion of a dosage a possible dosage error is indicated by the relay *FAILURE* (*terminal 6*).

With every *START* the relay *FAILURE* is reset.

A running dosage can be interrupted with the digital input *Stop* (Terminal 13, connected to 0 Volt). The relay *FAILURE* (*terminal 6*) shows the missing release at the *Stop*-input.

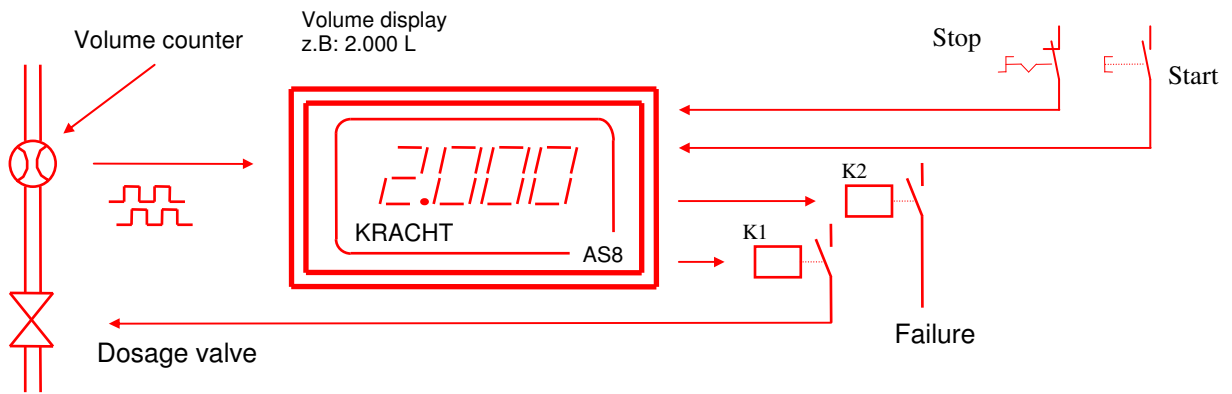

### 2.3 What failure display does the instrument offer?

Failures are displayed via the relay *FAILLURE* (terminal 6). Possible causes are:

- Faulty dosage: The permissible dosage percentage failure, entered under the menu code 01 was exceeded or falls short of it.
- Stop: The digital input *Stop* ( terminal 13) is connected to 0 Volt. No dosage release is present..
- Monitoring of volumetric displacement flowmeter: With two-channel flowmeters it is possible to monitor the correct impulse sequence of the channels. Faulty impulses are not counted and therefore do not change the measuring of the volume. If the AS8 registers a failure the additional signal train "**FAUL**" is shown.

+

The failure display can be switched off altogether. This is done under the menu code "**08**" at the position "**Failure display**". With a "**0**" the failure display is released, with a "**1**" the failure display is switched off. (See 4.1 Table of input values)

- Monitoring of dosage: If the AS8 does not receive any signals from the volumetric flowmeter during a filling process, the filling process will be terminated.

+

The monitoring of dosage can be switched off altogether. This is done under the menu code "**08**" at the position "**Mode**". With a "**0**" the monitoring of dosage is released, with a "**1**" the monitoring of dosage is switched off. (See 4.1 Table of input values)

### 2.4 Automatic Overflow Correction

When dosages are switched off, often overflows occur due to switching time of valves and control units.

An integrated overrun time function of the AS8 facilitates the automatic correction of these overflows.

### 2.5 How are faulty dosages monitored?

Dosage faults are indicated by the relay K2 *FAILURE*. After the completion of the filling process the actual percentage dosage fault is determined and compared with the permissible dosage fault. If the permissible fault is exceeded or falls short of it, the relay *FAILURE* is set.

+

The programming of the dosage fault is done under the menu code "**01-Percentage Dosage Fault**".

### 3. Connecting the AS8

This section deals with the layout of the connections on the AS8. The electrical connections are made on a screw terminal strip.

The connection layout for the desk-top unit and the 19" rack-mounted unit versions are covered in sections 10 and 11.

#### 3.1 Connecting the voltage supply

The AS8 is operated with an alternating voltage of 230 V or 115 V. The adjustment is achieved by means of solder jumpers underneath the transformer. The position of the solder jumpers is shown in section 8. **Setting the supply voltage.**

The connections are made as follows :

L	Terminal 1
N	Terminal 2
PE	Terminal 3



Fire prevention:

The unit should be protected by an external fuse on the supply side. In accordance with VDE 0411, in the event of failure, 8A / 150 VA must not be exceeded. The recommended external fusing is 100 mA at a supply voltage of 115 and 230 Volt.

### 3.2 Connecting the volume counter

The ASR16 is preferably operated in conjunction with KRACHT volume counters. However, other measuring systems with incremental signals can be connected. These can be, for example, oval wheel meters or angle of rotation sensors.

#### Sensor supply



The sensor supply is not short circuit proof.



The sensor supply is connected to connections 8 and 9. However, the sensor supply must not be used for the supply of unearthened inductance's or capacitive loads.

	Voltage	Ripple	Maximum permissible current
Terminal 8	+24 VDC +/- 20 %	load dependent	50 mA
Terminal 9	0 V		

#### Signal inputs

Measuring systems with incremental signals provide two square wave pulses. The square wave pulses are displaced from one another by 90°. It is therefore possible to detect the direction. This is referred to as a two channel layout.

If a measuring system with one square wave output is available, it is referred to as a single channel layout. In this case direction detection is not available.



Single channel or two channel connection must be set on the AS8. The settings required are made under menu reference „08“ at the “**meter input**” position (see **4.1 overview of the input values**).

Connection of the signal inputs is made on terminals 10 and 11. Connection terminal 11 is not used on the single channel layout.

	Channel 1	Channel 2
--	-----------	-----------

Counting input	Terminal 10	Terminal 11
----------------	-------------	-------------



The AS8 must be adjusted to the actual volume counter that is connected. The procedure is given in **section 4.2 What must be programmed when connecting a volume counter?**

### 3.3 Connecting the relay contacts

The AS8 has two relay contacts. The relays are designed as potential-free contacts. That is to say, the user must input the potential at the base terminal.



The relays are provided with normally-open contacts. The switching voltage is 24 V, maximum switching current is 1A. Voltages greater than 48 V must not be switched on any account.

Relay	Contact ( Signal )	Common terminal (Base)
-------	--------------------	------------------------

K1	Terminal 5	Terminal 7
K2	Terminal 6	Terminal 7

#### How do the relays operate ?

The function of the relays are:

- The relay K1 switch the dosage valve.
- The relay K2 signals a possible dosage error or a failure.

With every *START* the relay K2 ( *FAILURE* ) is reset.

## 4. AS8 programming

Each time the AS8 is to be operated, it is necessary to adapt the unit to the volume counter that is connected.

### Input procedure:

The input procedure is the same for all input values and is therefore described once only.

Programming is carried out by means of the three keys **F1** , **F2** and **F3** .

### Start input operation

**F1** and **F2** are depressed for approx. four seconds to start the input operation.

The first three segments are switched dark, segments four and five display the menu reference number "00".

Release **F1** and **F2** .

### Change menu reference

By briefly pressing **F1** the menu reference numbers "00" to "08" can be displayed in sequence.

An input value is concealed behind each menu reference number.

To display the input value, press **F3** briefly. A four digit input value appears.

### Change input value

The point marks the digit which can be changed by actuating **F3** . The point can be moved by actuating **F2** .

After setting the numerical values the point must be placed at the correct position.

On actuating **F1** , the display reverts to the menu-reference level.

The menu reference "00" is displayed again.

### Stop input value

To exit the input operation, depress **F1** again for approx. four seconds.

#### 4.1 Overview of the input values

The values which are required to be set can be inserted in the column labelled "Input value-User".

Menu - Reference	Standard setting	Input value - User	Function
<b>00</b>	0.040		Pulse volume of volume counter
<b>01</b>	1.500		Percentage Dosage Fault
<b>02</b>	0000.		Dosing value 1
<b>03</b>	0000.		Dosing value 2
<b>04</b>	0000.		Dosing value 3
<b>05</b>	0000.		Dosing value 4
<b>06</b>	0000.		Dosing value 5
<b>07</b>	0000.		Dosing value 6
<b>08</b>	0000		Counter input : <b>0</b> = 2-channels / <b>1</b> = 1 channel Error display : <b>0</b> = Activated / <b>1</b> = Blocked Monitoring of dosage: <b>0</b> = Activated / <b>1</b> = Blocked

#### 4.2 What must be programmed when connecting a volume counter?

The AS8 Microcontroller is set-up for the connected volume counter. This is carried out under menu reference “00 - pulse volume counter” and under menu reference “08” at the position “counter input”.

The pulse volumes for KRACHT Volume counters can be obtained from the table.

The “X” characters in the “Input value Menu reference 08” column are of no significance in setting the volume counter.

Designation	Material	Input value Menu reference 00	Input value Menu reference 08
-------------	----------	----------------------------------	----------------------------------

VC 0,025	Sp. Gr. Iron*	0,025 cm <sup>3</sup>	XXX0 2 channels
VC 0,04	Sp. Gr. Iron	0.040 cm <sup>3</sup>	XXX0 2 channels
VC 0,2	Sp. Gr. Iron	0.245 cm <sup>3</sup>	XXX0 2 channels
VC 1	Sp. Gr. Iron	1.036 cm <sup>3</sup>	XXX0 2 channels
VC 5	Sp. Gr. Iron	5.222 cm <sup>3</sup>	XXX0 2 channels
VC 10	Sp. Gr. Iron	10.48 cm <sup>3</sup>	XXX0 2 channels
VC 2	Aluminium	2.000 cm <sup>3</sup>	XXX1 1 channel
VC 0,2	High grd. St.*	0.200 cm <sup>3</sup>	XXX0 2 channels
VC 1	High grd. St.	1.000 cm <sup>3</sup>	XXX0 2 channels
VC 3	High grd. St.	3.000 cm <sup>3</sup>	XXX0 2 channels
VC 5	High grd. St.	5.000 cm <sup>3</sup>	XXX0 2 channels

\* Sp. Gr. Iron = Spheroidal graphite iron      \* High grd. St. = High grade steel

#### Example:

A VC0.04 volume counter is connected. The pulse volume is 0.040 cm<sup>3</sup>. The VC 0.04 Volume counter has a 2 channel layout.

- The value 0.040 is entered under menu reference “00”.
- A “0” is entered under menu reference “08” at the position designated “counter input”.

### **4.3 Which display parameters can be represented (DIP switches) ?**

The physical parameters “l” and “Usgal” can be set as display units. Switching between the display parameters is achieved using the DIP switches. The DIP switches are located behind the front cover.

Setting the volume:

SW 1	Function	Factory setting
OFF	Indication in LITRES	X
ON	Indication in USGAL	

## 5. Technical Data

<b>Processor</b>	PIC 17C42
Power pack Supply Power consumption Sensor supply	230 V AC, +6% ... -10% / 50-60 Hz, optional 115 V AC ca. 3.5 W 24 V DC +/- 20%, 50 mA
<b>General data</b>	
Display	Principle : 7 Segment LED, 13.2 mm, red Display :0.000 ... 9999 with floating point overrun ( >9999 ) : display 9999 overrun ( <-9999 ) : display -9999 Status indication : LED K1 and K2 for relays 1 and 2
Control keys Housing Front frame Installed depth Panel cut-out Protection class (DIN 40050) Weight Connections	Three keys behind the front cover Control panel housing in plastic 96x48 mm, DIN 43700 ca. 122 mm with terminal strip 92x45 mm, Tol +0.8 x +0.6 mm IP 54 with appropriate control panel installation ca. 0.4 kg 15 pole screw terminal strip
<b>Relay contacts</b>	each 1 N.O., 24 Volt / 1 A, typ. operating time 6 ms
<b>Digital inputs</b>	
Input impedance Input amplitude Operating time	>= 7500 Ohm low <= 9 Volt, high >= 12 Volt typ. 1 ms
<b>Analogue outputs</b>	Set as voltage or current output via jumpers
Voltage output Current output	+/- 10 Volt, 0 - 10 Volt, 2 - 10 Volt / load >= 1 kOhm, Resolution 10 bit, short-circuit proof +/- 20 mA, 0 - 20 mA, 4 - 20 mA / load <= 250 Ohm, Resolution 10 bit, short-circuit proof
<b>Volume counter inputs</b>	
Input impedance Input amplitude Measuring principle, flow rate Maximum input frequency Measuring range, totalisator	>= 7500 Ohm low <= 9 Volt, high >=12 Volt Period of oscillation measurement (rising edge) 1Hz ... 2500 Hz 2 x 10 <sup>9</sup> pulses
<b>Serial interfaces</b>	Screened data cable recommended
<u>RS 232</u> Input voltage Input current Output current Setting Cable	Cable length <= 15 m max. +/-30 V typ. +/- 3 mA at +/- 9 V input voltage typ. +/- 3 mA 9600 baud, 8 bit, no parity, 1 stop bit Screened data cable recommended
<b>Ambient conditions</b>	
Operating temperature Storage temperature	0 C to + 60 °C -25 °C to +85 °C

## 6. Type code

Example :

AS8 - U - 230 / .

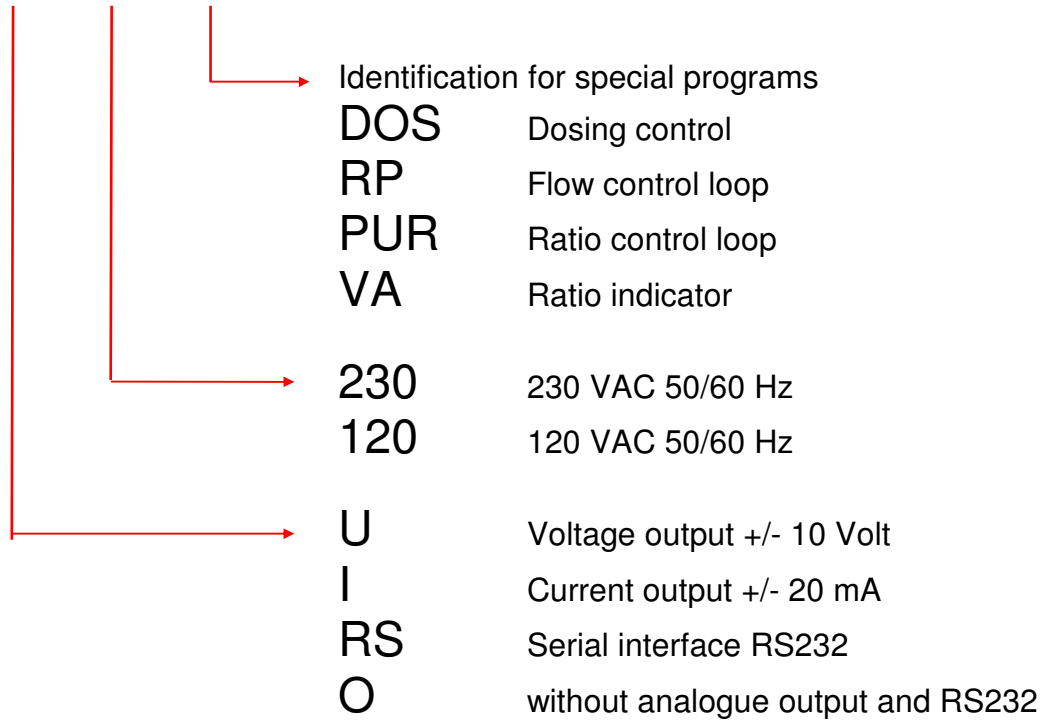

## 7. Connections

The electrical connections are made on plugable screw terminals.



Stranded connections on the basis of the prevention of accidental contact in accordance with VDE 0411 Part 100 only by means of connector sleeves with insulating material caps. Non-factory wired connections should not be otherwise connected.

It is recommended that all signal connection leads are screened and the screening earthed on both sides, in order to avoid HF interference. The signal connection leads should not be combined in the same cable assembly as mains cables, motor cables, etc.

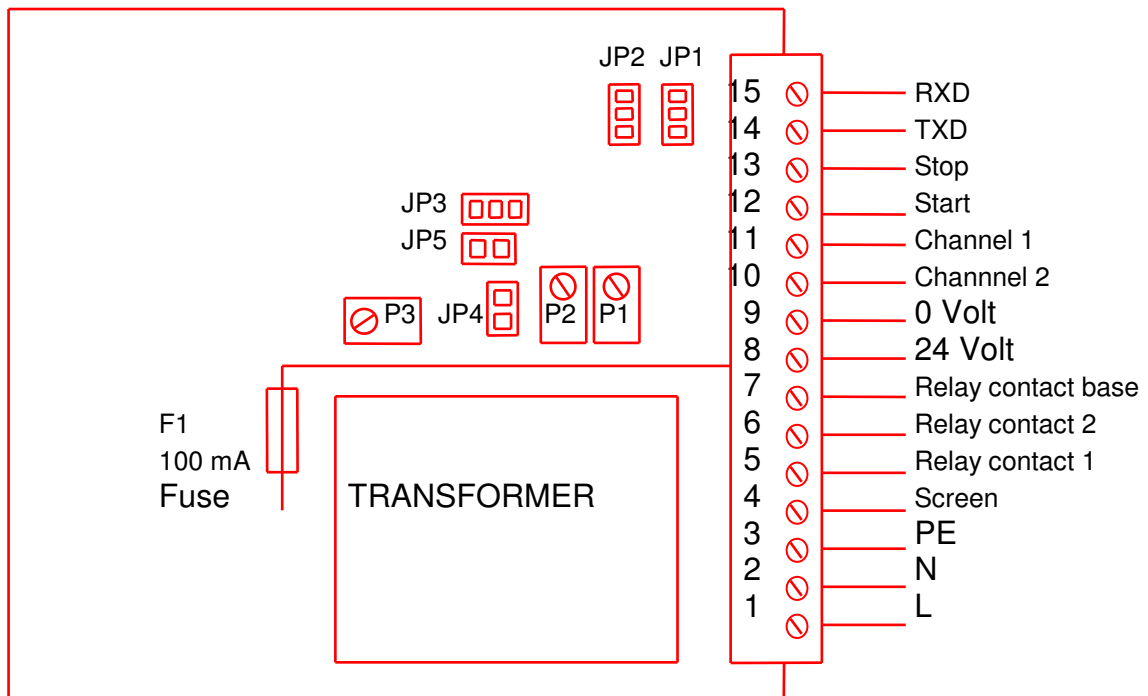

# 8. Setting the supply voltage

Supply voltage 230 V AC/ 50-60 Hz

View of circuit board from below  
Close solder jumper 1 to 3

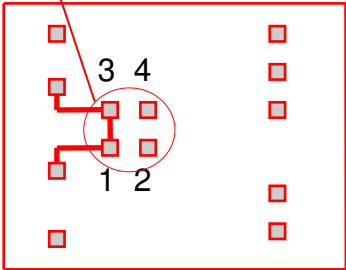

The diagram shows a 2x4 grid of pins. The top row pins are labeled 3 and 4, and the bottom row pins are labeled 1 and 2. A red line connects pin 1 to pin 3, forming a bridge. A red circle highlights the connection point between pins 1 and 3. A red arrow points from the text 'Close solder jumper 1 to 3' to this connection point.

supply voltage 115 V AC/ 50-60 Hz

View of circuit board from below  
Close solder bridges 1 to 2 and 3 to 4

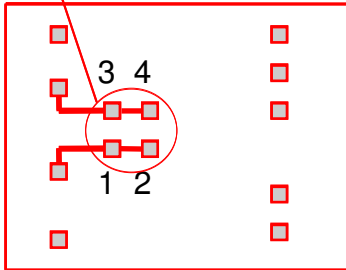

The diagram shows a 2x4 grid of pins. The top row pins are labeled 3 and 4, and the bottom row pins are labeled 1 and 2. Red lines connect pin 1 to pin 2 and pin 3 to pin 4, forming two bridges. A red circle highlights the connection points between pins 1-2 and 3-4. A red arrow points from the text 'Close solder bridges 1 to 2 and 3 to 4' to these connection points.

## 9. Dimensions

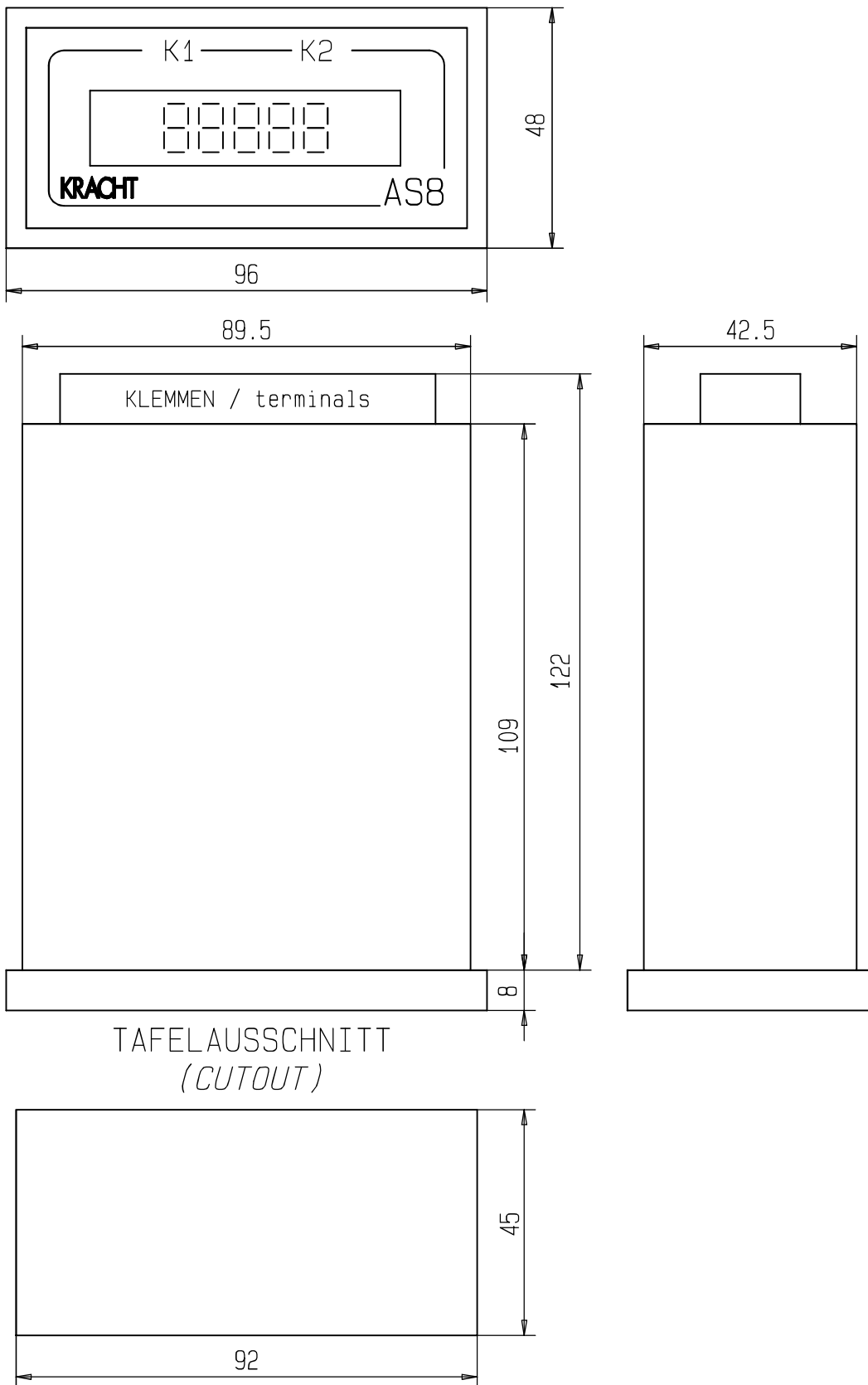

## 10. AS8 as 19" Rack Unit

The AS8 is built into a 3HE 25TE 19" front plate. All the connections for the AS8 are wired on a Eurocard and are available on a 32 pin contact strip for further connection.

### AS8 wiring on the contact strip:

#### Contact PIN

ac2 →  
 ac4 →  
 ac6 →  
 ac8 →  
 ac10 →  
 ac12 →  
 ac14 →  
 ac16 →  
 ac18 →  
 ac20 →  
 ac22 →  
 ac24 →  
 ac26 →  
 ac28 →  
 ac30 →  
 ac32 →

#### AS8 terminal

8 24 Volt sensor supply  
 10 Volume counter channel A  
 11 Volume counter channel B  
 12 Start  
 13 Stop  
 14 TXD  
 15 RXD  
 5 Relay contact 1  
 6 Relay contact 2  
 2 N  
 1 L  
 3 PE  
 7 Relay contact base  
 9 0 Volt

### View:

