

Function and Product Characteristics AS 8



Function

- The microcontroller AS 8 processes incremental input signals from KRACHT volume counters and other sensors.
- The input signals are filtered in the unit, interpreted and converted into the values of flow rate and volume.
- The user may choose to have either flow rate or volume displayed.
- Two relays, one analogue output or one serial interface are available for further, external processing.
- As an option, the AS 8 is also available with three keys on the front panel.

Product Characteristics

- EMC construction (electromagnetic compatibility)
- Programmable micro-processor
- Used for KRACHT volume counters and other sensors with 24 volt incremental signals
- Power supply voltage
230/120 V- 50/60 Hz, 24 VDC, 12 VDC
- Integrated sensor power supply 24 VDC-50 mA
- Flow rate or volume measurement
- Smoothing function by means of a digital filter
- 2 programmable relays
- User-selected analogue output

Current	± 20 mA, 0...20 mA, 4...20 mA
Voltage	± 10 V 0...10 V
- Serial interface RS 232
- Selectable time basis (sec, min, hrs)
- Selectable units for display
- Enclosure with dimensions according to DIN

Technical Data AS 8

Processor	PIC 17C42
Supply	230 VAC, + 6% ... - 10% / 50 - 60 Hz, optional 120 VAC, 24 VDC, 12 VDC
Power input (power consumption)	approx. 3.5 W
Sensor supply	24 VDC \pm 20%, 50 mA
General data	
Display	principle: 7 segment LED, 13.2 mm, red display: 0.000 ... 9999 with floating decimal point overflow (>9999): display 9999 overflow (<-9999): display -9999 status indicator: LEDs K1 and K2 for relays 1 and 2
Keyboard	three keys behind the front panel, optional keys on front panel
Housing	for switch panel plug-in unit made of plastic
Panel frame	96 x 48 mm, DIN 43700
Insertion depth	ca. 122 mm with plug board
Panel cutout	92 x 45 mm, tolerance + 0.8 x + 0.6 mm
Protection (DIN 40050)	IP 54 in appropriate switch panel mounting
Weight	approx. 0.4 kg
Connections	15 pins terminal connecting block
2 relay contacts	one normally-open-contact switching-time each
2 digital inputs	
Input impedance	\geq 7500 Ohm
Input amplitude	low \leq 9 volt, high \geq 12 volt
Switching time	typ. 1 ms
1 analogue output	
Voltage output	current or voltage output adjustable by means of jumper \pm 10 volt, 0 - 10 volt, 2 - 10 volt / load \geq 1 kOhm, or 10 bit resolution, short-circuit-proof
Current output	\pm 20 mA, 0 - 20 mA, 4 - 20 mA / load \leq 250 Ohm, 10 bit resolution, short-circuit-proof
1 volume counter input	
Input impedance	\geq 7500 Ohm
Input amplitude	low \leq 9 volt, high \geq 12 volt
Rate-of-flow principle of measurement	period length measurement (rising tooth flank)
Maximum input frequency	1Hz ... 2500 Hz
Measurement range totalizer	2×10^9 pulses
Serial interface	
RS 232	cable length \leq 15 m
Input voltage	max. \pm 30 V
Input current	typ. \pm 3 mA at \pm 9 V input voltage
Output current	typ. \pm 3 mA
Adjustment (selection)	9600 baud, 8 bit, no parity, 1 stop bit
Cable	shielded data cables recommended
Ambient conditions	
Operating temperature	0 °C up to + 60 °C
Storage temperature	-25 °C up to + 85 °C

Type Key AS 8

Ordering example

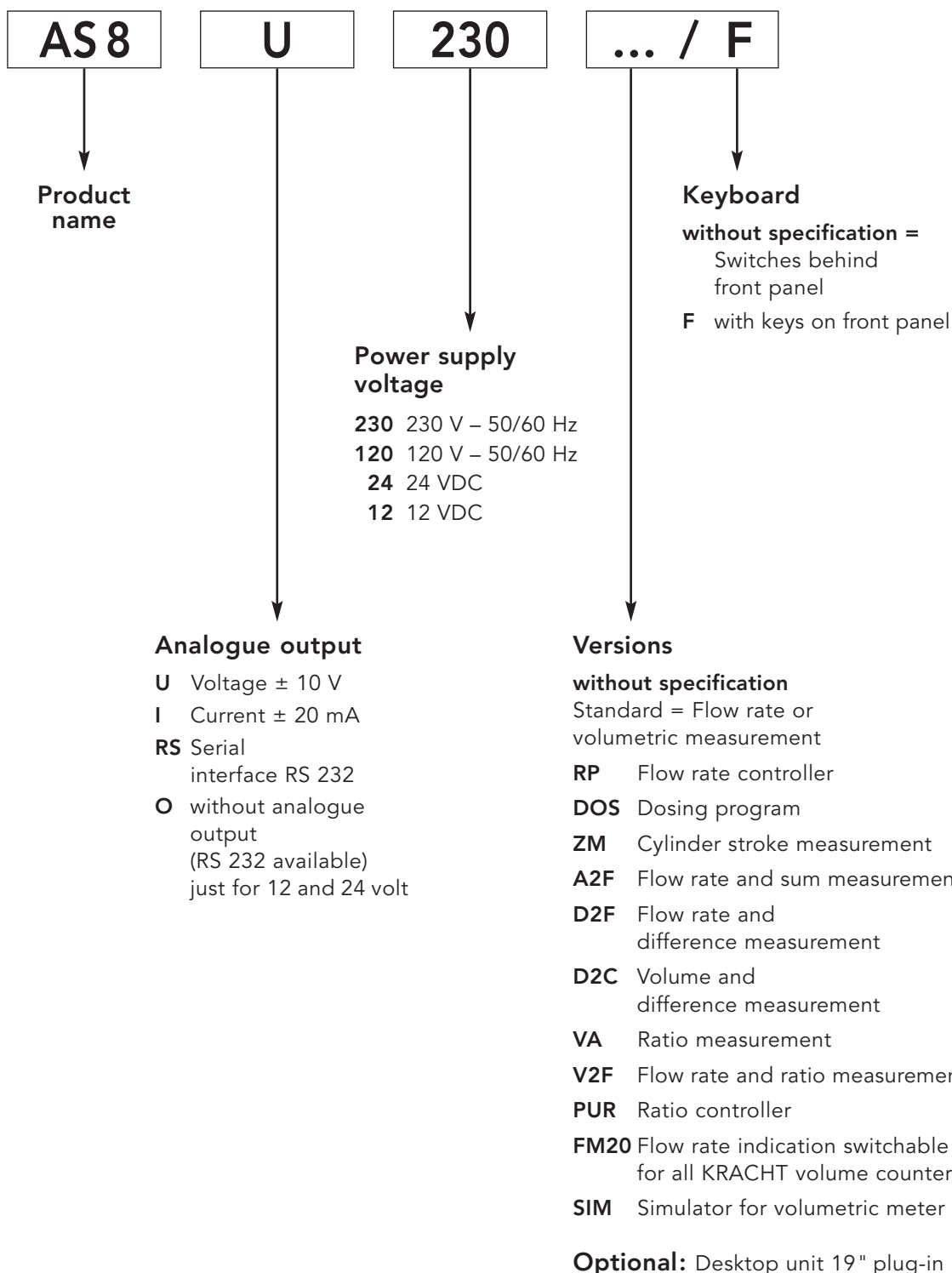

Dimensions AS 8

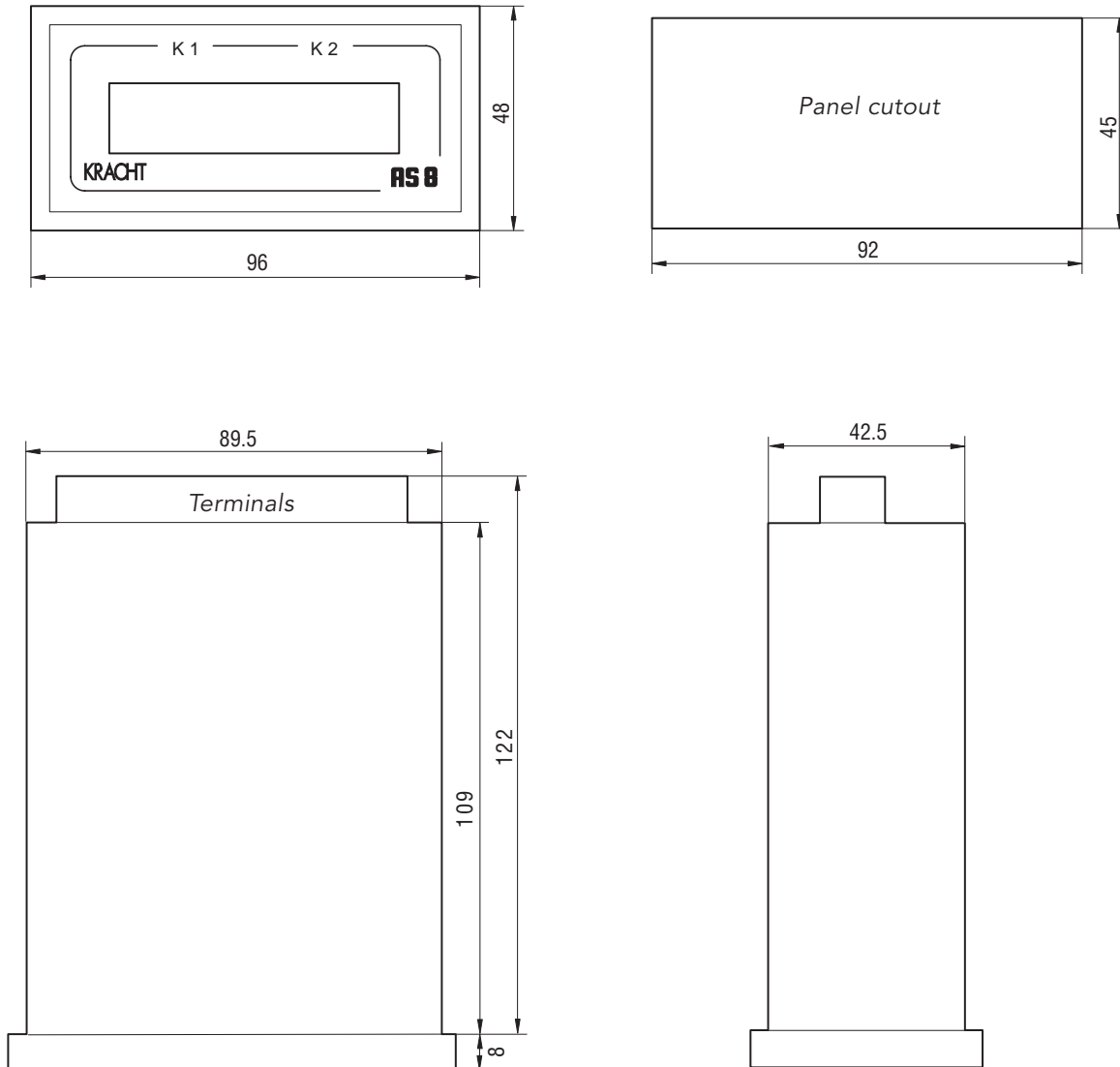

Dimensions in mm

Flow Rate Measurement AS 8 - Standard

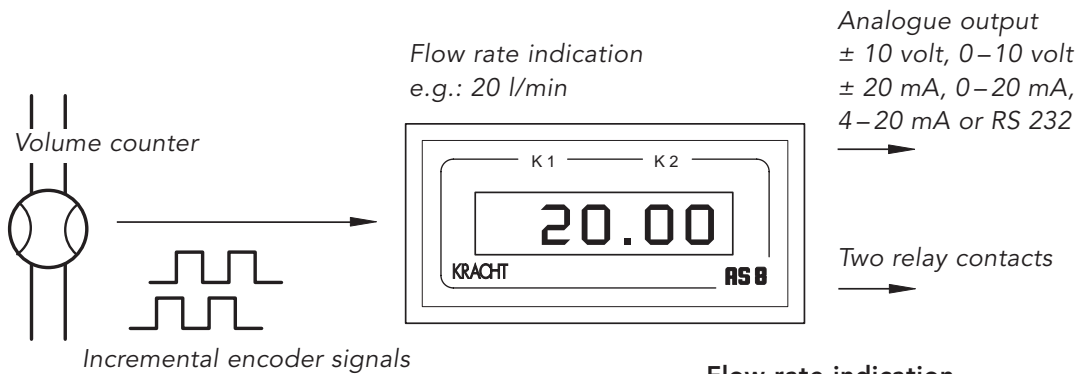

Flow rate indication

- The incremental input signals are filtered, converted and processed by the microcontroller to give the corresponding flow rate.
- Any of the following physical units can be set for the indicator reading:
l/h, l/min, l/s, or US gal/hr, US gal/min, US gal/s.

Volumetric Measurement AS 8 - Standard

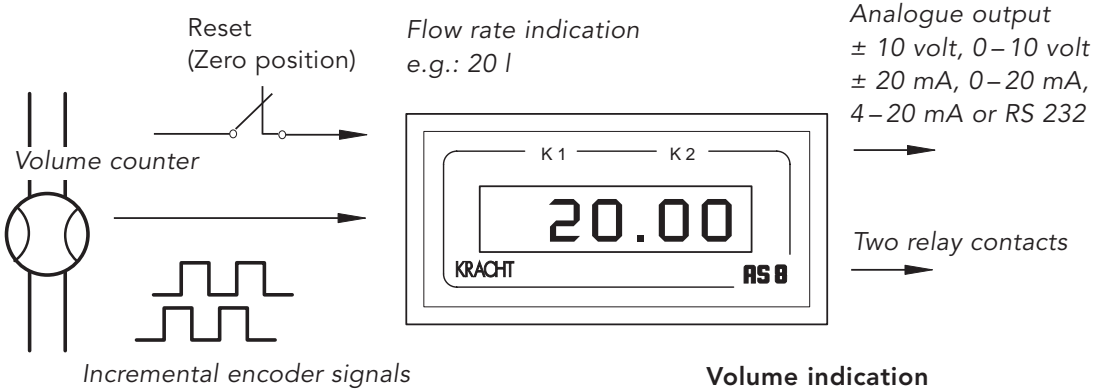

Volume indication

- The incremental input signals are summarized and converted to the dimensions of volume by the microcontroller, using a programmable factor.
- The physical units l and US gal can be set for display.
- A 24 volt digital input enables the summation to be reset to zero.

Functional Characteristics AS 8 - Standard

- The standard version AS 8 is an indication and control device for dynamic flow rate and volume measurement. The setting is made by means of three keys, which are accessible behind the front cover. Optional via keys on front panel (version /F).
- The switch-over between the display units is made by means of DIP switches, located behind the front cover.
- Two programmable relays, an analogue output, or an RS 232 serial interface, are available for further external processing.
- The integrated 24 VDC transducer supply enables the volume counter to be directly connected.
- The type AS 8 series measuring devices are available as built-in control panel units, as bench units or as 19" rack-mounted units.

Flow Rate Controller AS 8 - RP

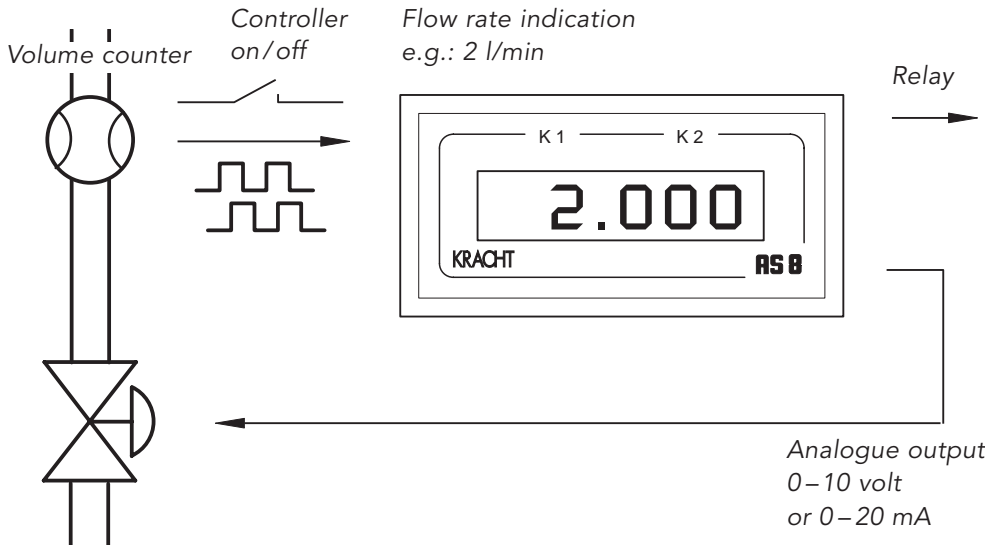

Flow rate controller

- The AS 8-RP Flow rate controller version controls the flow rate of a component. The required flow rate is set on the AS 8. The flow rate is detected by the volume counter and fed to the AS 8 as a square-wave signal.
- The controller output is connected to a continuously variable valve via a position amplifier, or is used to control the speed of a dosing pump.

Rotational Speed Controller AS 8 - RP

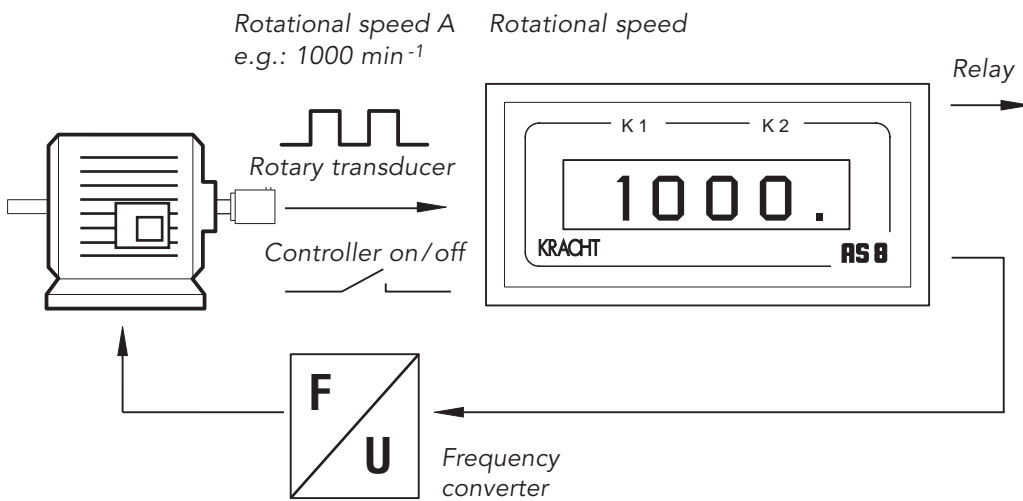

Rotational speed controller

- A further application example is that of rotational speed regulation. The required speed is set on the AS 8. The actual rotational speed is detected by the rotary transducer and fed to the AS 8 as a square-wave signal.
- The controller output is connected to the motor via a frequency converter and used to control the rotational speed

Functional Characteristics AS 8 - RP

- Two relay contacts enable the overshoot of permissible error bandwidths to be signalled.
- Programming and setting is carried out by means of three keys which are accessible on removal of the front cover. Optional via keys on front panel (version /F).
- The integrated 24 VDC transducer supply enables the direct connection of the volume counter.
- The type AS 8 series measuring devices are available as built-in control panel units, as bench units, or as 19" rack-mounted units.

Dosing AS 8 - DOS

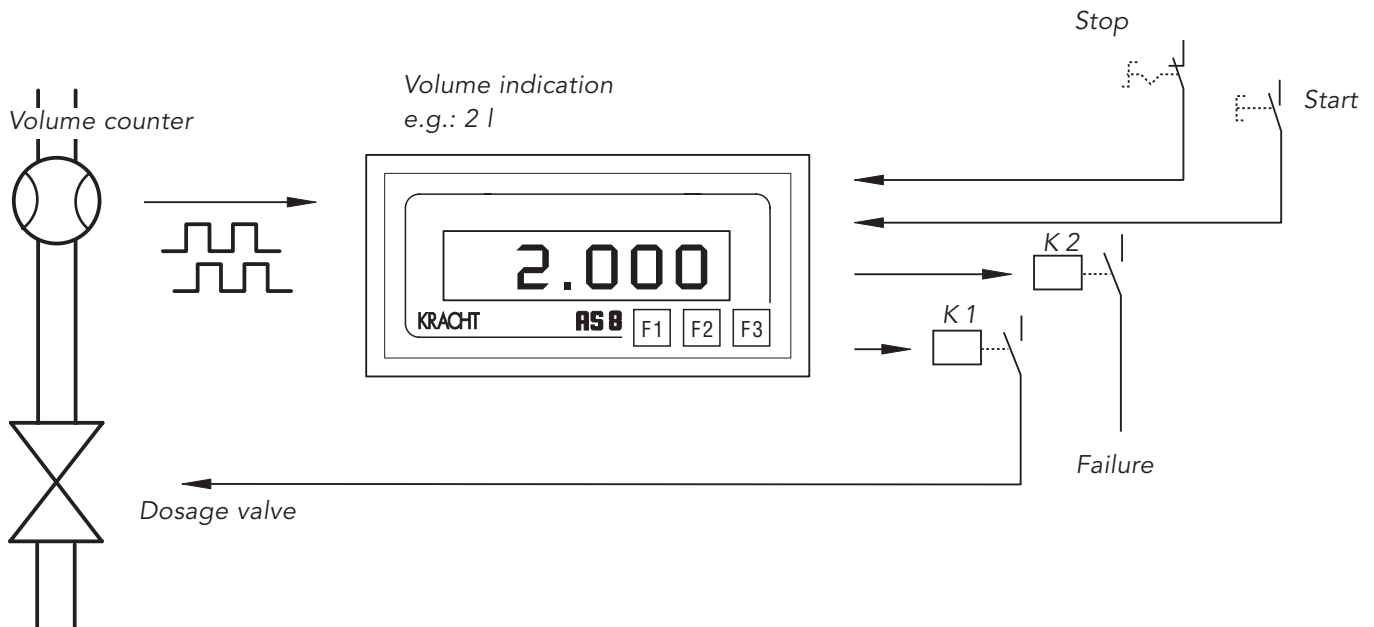

Functional Characteristics AS 8 - DOS

- The AS 8 dosing version is especially designed for employment in dosing lines. It allows one volume counter to be connected.
- 6 dosages (programmes) can be stored in the AS 8. Specific dosages are called up via the three keys on the front panel. The input values are arranged in menus.
- The filling process is started by the digital input. The AS 8 resets the last dosage quantity and switches the dosage valve. The volume counter measures the flow and delivers square wave signals to the AS 8.
- The AS 8 sums the input signals. When the quantity is reached the dosage valve will be switched.
- The second relay contact enables the indication of faulty dosages.
- The settings are made by using the three keys on the front panel. The input values are arranged in menus.
- The integrated 24 VDC sensor supply enables direct connection to the volume counter.
- The type AS 8 measuring devices are available as built-in control panel units, as desk-top units, or as 19" rack-mounted units

Cylinder Stroke Measurement AS 8 - ZM

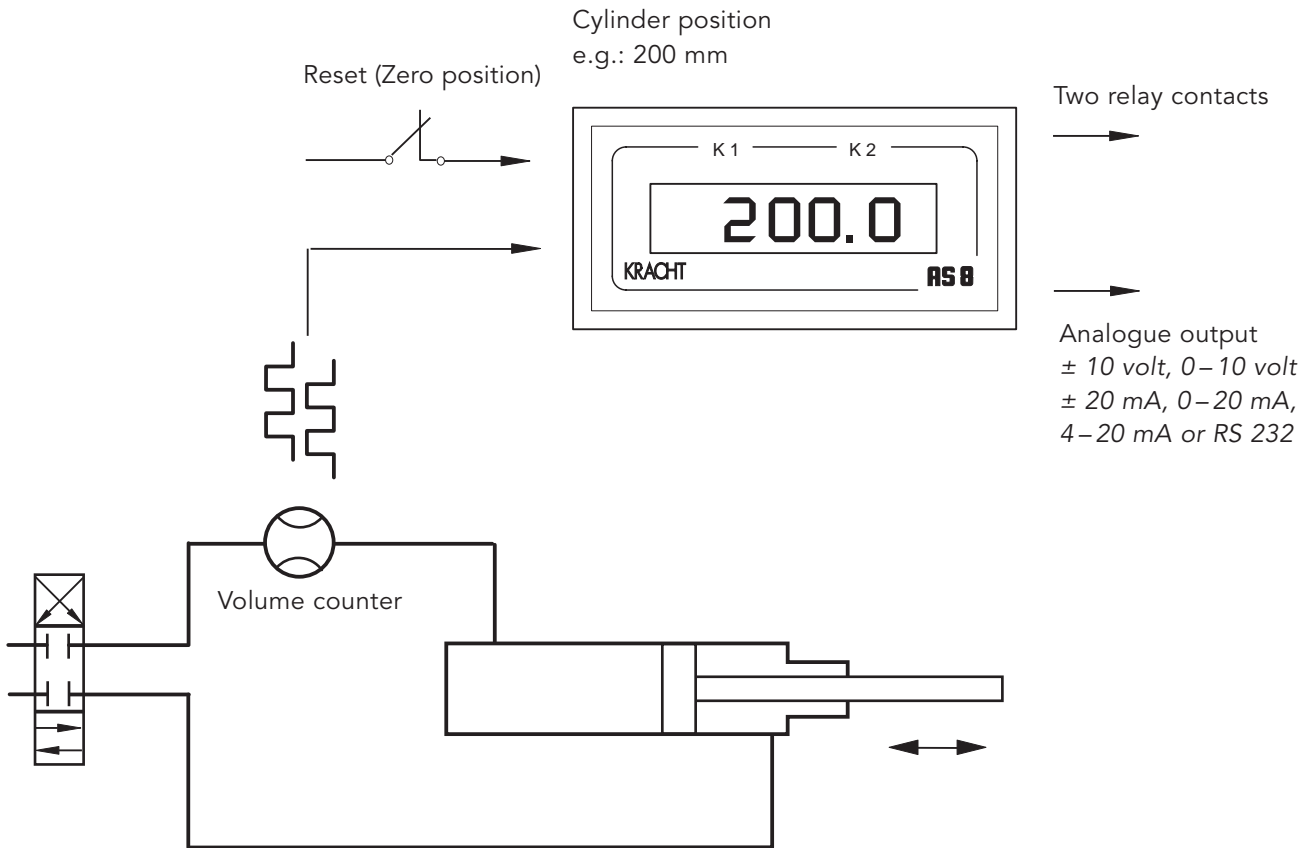

Functional Characteristics AS 8 - ZM

- The cylinder stroke measurement version of the AS 8 enables an indirect measurement to be made of hydraulic drive movements, in combination with a volume counter.
- In this system, the volume counter is installed in an operating line, to generate pulses which are proportional to the flow rate and to indicate the direction of flow.
- The electrical pulses are converted by the micro-controller into the physical dimensions of flow rate and volume, or stroke and velocity.
- Erroneous measurements, due to leakage at the end positions, can be prevented by means of a programmable blocking frequency. The signals are only processed when the flow rate exceeds the blocking frequency.
- Two relays, an analogue output or an RS 232 interface, are available for additional external processing.
- Programming and setting is carried out by means of three keys, which are accessible behind the front cover.
- The integrated 24 VDC transducer supply enables the direct connection of the volume counter.
- The type AS 8 series measuring devices are available as built-in control panel units, as bench units, or as 19" rack-mounted units

Flow Rate and Sum Measurement AS 8 - A2F

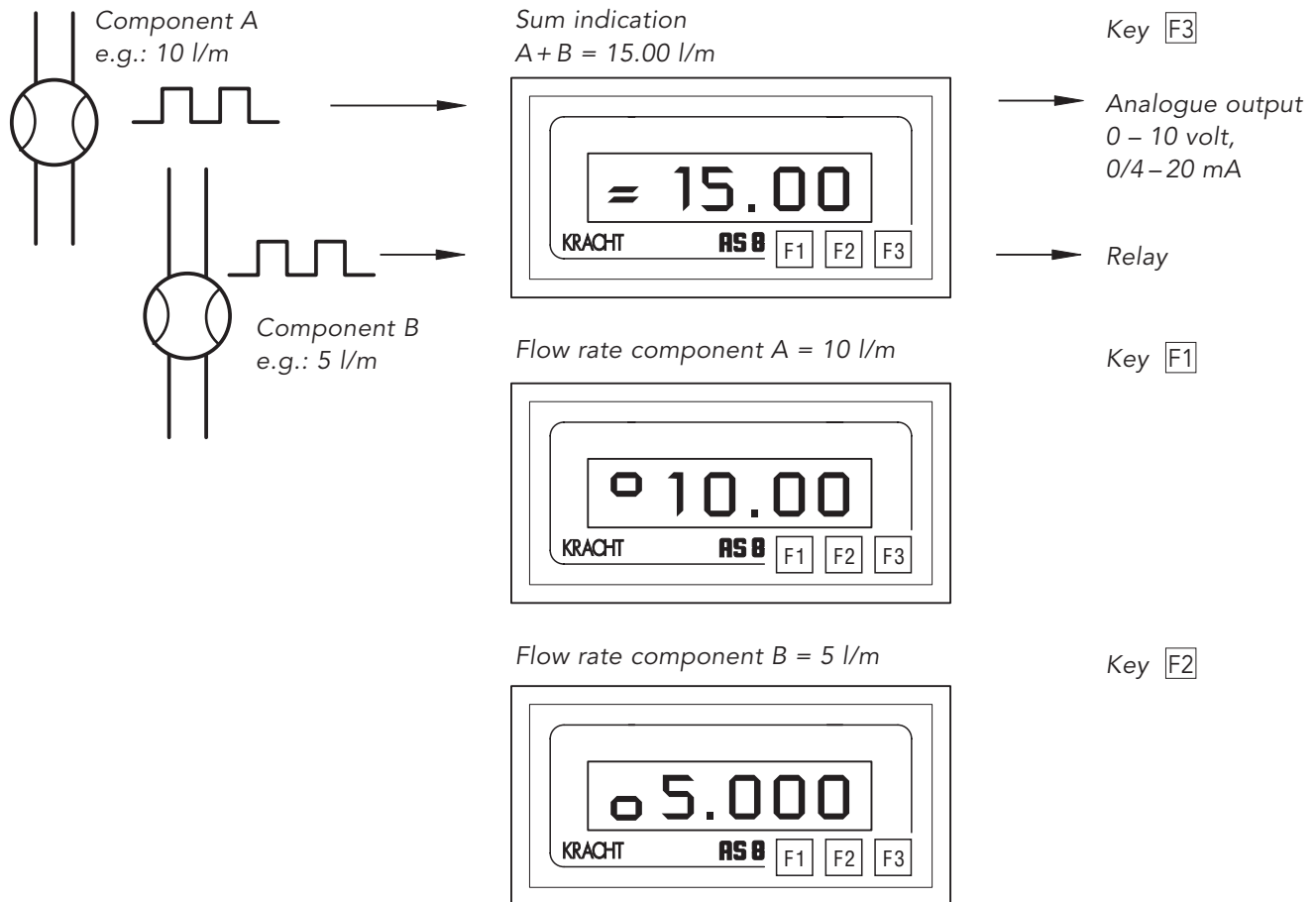

Functional Characteristics AS 8 - A2F

- Two volume counters could be connected to the AS 8-A2F. The AS 8 shows the flow rate of component A and B and the sum A + B.
- The different indications are switched by the keys **F1**, **F2** and **F3**.
- For each volume counter a density factor can be put in.
- One square-wave signal is required of each volume counter. The input signals are filtered, converted and processed by the microcontroller to give a sum.
- The settings are made using the three keys on the front panel. The input values are arranged in menus.
- Two relay contacts, an analogue output or an RS 232 interface are available for additional external processing.
- The integrated 24 VDC transducer supply enables the direct connection of the volume counter.
- The type AS 8 series measuring devices are available as built-in control panel units, as bench units, or as 19" rackmounted units.

Flow Rate and Difference Measurement AS 8 - D2F

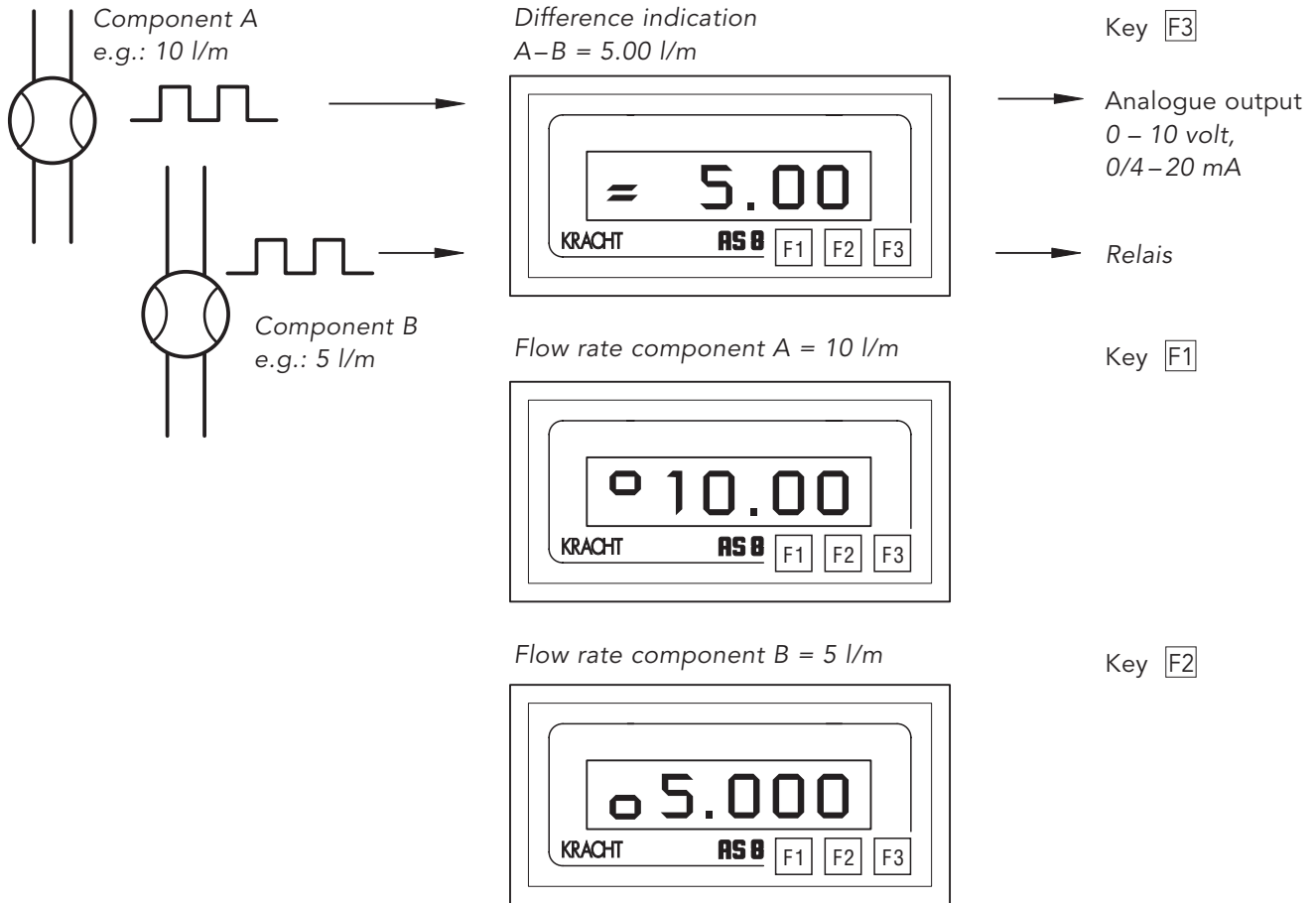

Functional Characteristics AS 8 - D2F

- Two volume counters could be connected to the AS 8-D2F. The AS 8 shows the flow rate of component A and B and the difference A-B.
- The different indications are switched by the keys **F1**, **F2** and **F3**.
- For each volume counter a density factor can be input.
- One square-wave signal is required of each volume counter. The input signals are filtered, converted and processed by the microcontroller to display the difference.
- The settings are made using the three keys on the front panel. The input values are arranged in menus.
- Two relay contacts, an analogue output or an RS 232 interface are available for additional external processing.
- The integrated 24 VDC transducer supply enables the direct connection of the volume counter.
- The type AS 8 series measuring devices are available as built-in control panel units, as bench units, or as 19" rackmounted units.

Volume and Difference Measurement AS 8 - D2C

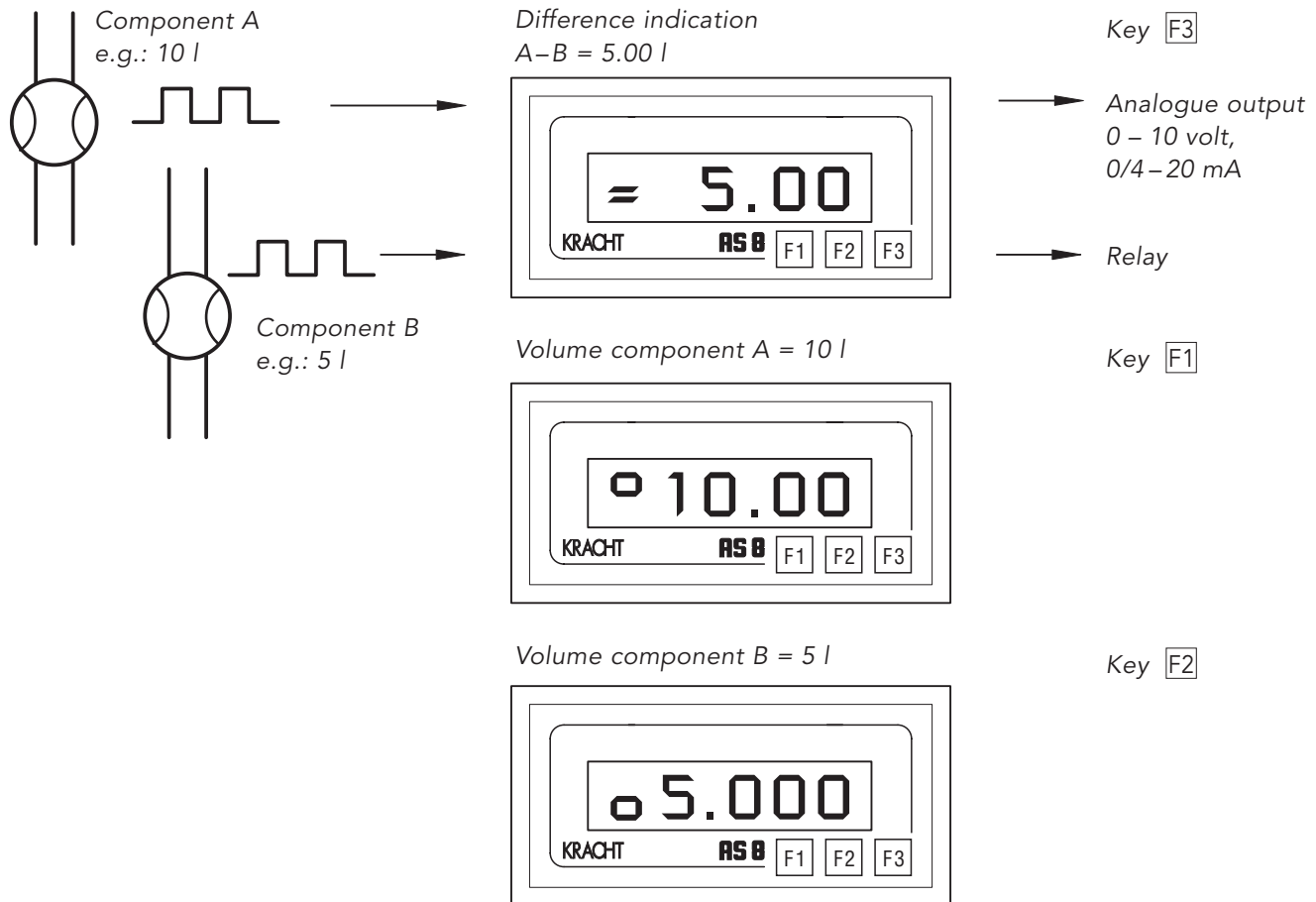

Functional Characteristics AS 8 - D2C

- Two volume counters could be connected to the AS 8-D2C. The AS 8 shows the volume of component A and B and the difference A-B.
- The different indications are switched by the keys **F1**, **F2** and **F3**.
- For each volume counter a density factor can be input.
- One square-wave signal is required of each volume counter. The input signals are filtered, converted and processed by the microcontroller to display the difference.
- The settings are made using the three keys on the front panel. The input values are arranged in menus.
- Two relay contacts, an analogue output or an RS 232 interface are available for additional external processing.
- The integrated 24 VDC transducer supply enables the direct connection of the volume counter.
- The type AS 8 series measuring devices are available as built-in control panel units, as bench units, or as 19" rackmounted units.

Mixture ratio measurement AS 8 - VA

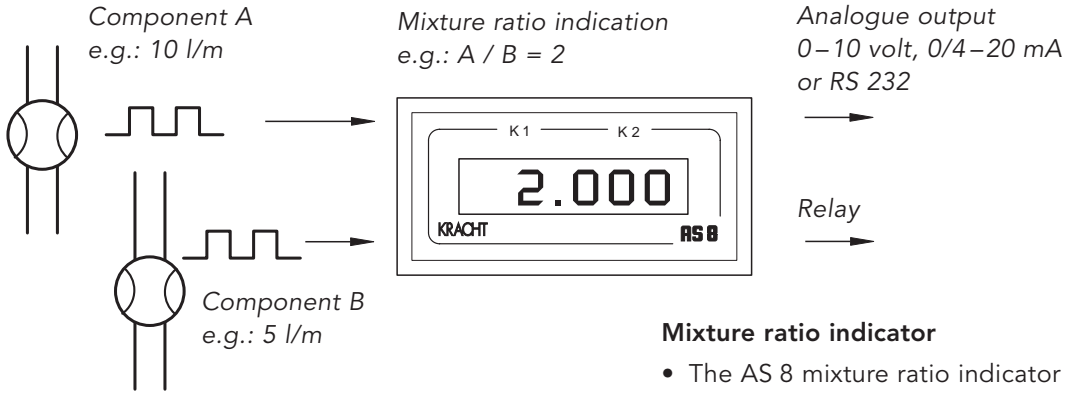

Mixture ratio indicator

- The AS 8 mixture ratio indicator displays the mixture ratio of two components.
- A square-wave signal is required from each volume counter. The input signals are filtered, converted and processed by the micro-controller to give a mixture ratio.

Rotational Speed Ratio Measurement AS 8 - VA

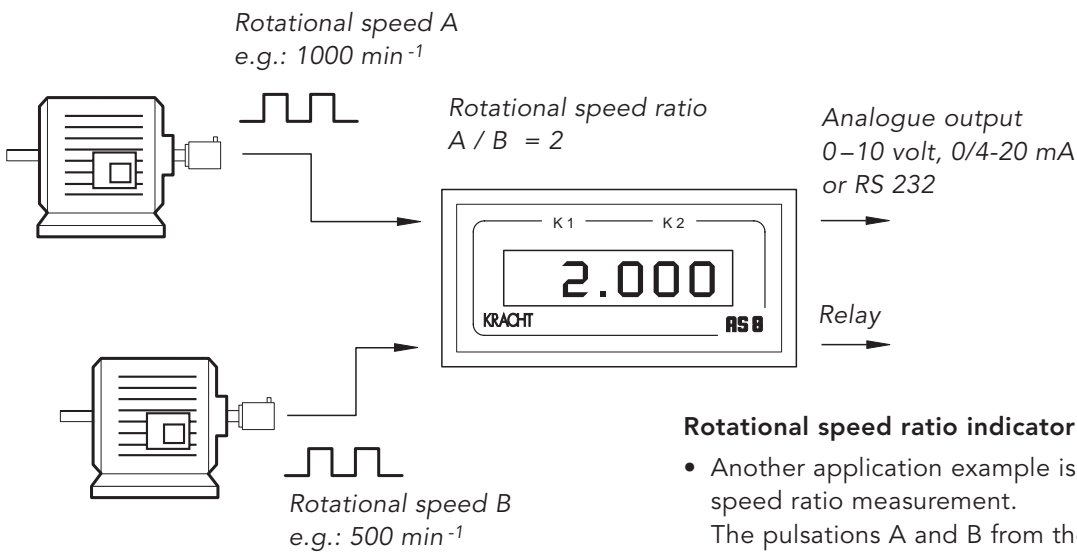

Rotational speed ratio indicator

- Another application example is that of rotational speed ratio measurement. The pulsations A and B from the rotary transducers are detected and indicated on the AS 8 as a rotational speed ratio.

Functional Characteristics AS 8 - VA

- Two programmable relays, an analogue output, or an RS 232 serial interface, are available for further external processing.
- The programming and settings are achieved via three keys, accessible on removal of the front cover. Optional via keys on front panel (version /F).
- The integrated 24 VDC transducer supply enables the direct connection of the volume counter.
- The type AS 8 series measuring devices are available as built-in control panel units, as bench units, or as 19" rack-mounted units.

Flow Rate and Ratio Measurement AS 8 - V2F

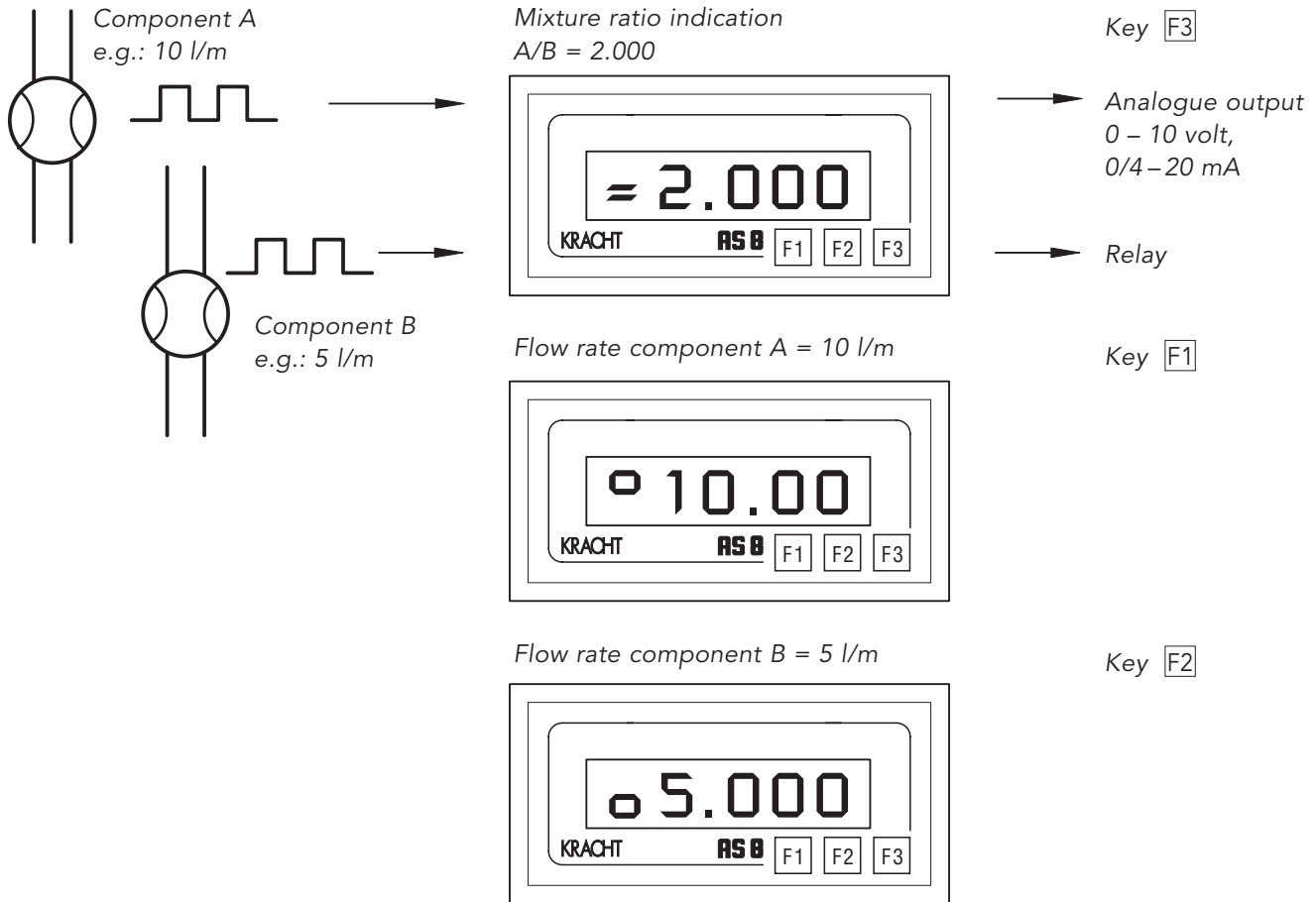

Functional Characteristics AS 8 - V2F

- Two volume counters could be connected to the AS 8-V2F. The AS 8 shows the flow rate of component A and B and the mixture ratio A/B.
- The different indications are switched by the keys **F1**, **F2** and **F3**.
- For each volume counter a density factor can be input.
- One square-wave signal is required of each volume counter. The input signals are filtered, converted and processed by the microcontroller to give a mixture ratio.
- The settings are made using the three keys on the front panel. The input values are arranged in menus.
- Two relay contacts, an analogue output or an RS 232 interface are available for additional external processing.
- The integrated 24 VDC transducer supply enables the direct connection of the volume counter.
- The type AS 8 series measuring devices are available as built-in control panel units, as bench units, or as 19" rackmounted units.

Ratio Controller AS 8 - PUR

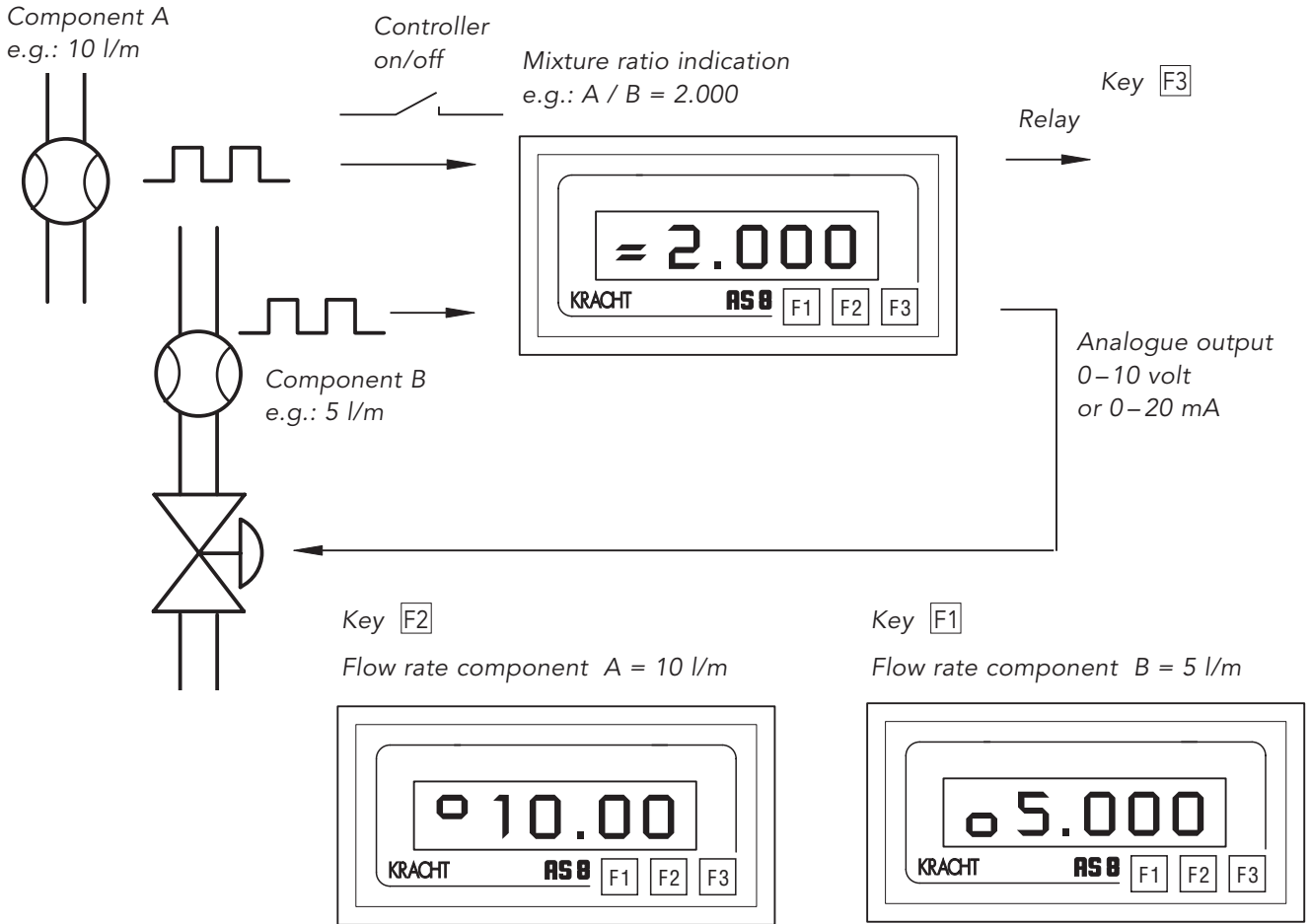

Functional Characteristics AS 8 - PUR

- The ratio controller version of the AS 8 controls the mixture ratio of two components and shows the flow rate of the components A and B as well as the mixture ratio A/B.
- The different indications are switched by the keys **F1**, **F2** and **F3**.
- The volumetric flows are detected by the volume counter and fed to the AS 8 as square-wave signals. The input signals are filtered, converted and processed by the microcontroller, to give a mixture ratio. The controller output is either directly connected, or connected via a position amplifier, to a continuously controllable valve, or used to control the speed of a dosing pump.
- Two relay contacts enable the overshoot of permissible error bandwidths to be signalled.
- All settings are made using three keys, which are accessible behind the front cover. Optional via keys on front panel (version /F). The input values are arranged in menus.
- The integrated 24 VDC transducer supply enables the direct connection of the volume counter.
- The type AS 8 series measuring devices are available as built-in control panel units, as bench units, or as 19" rackmounted units.

AS 8 in the Desk-top Housing

The desk-top housing is available with analogue output or serial interface.

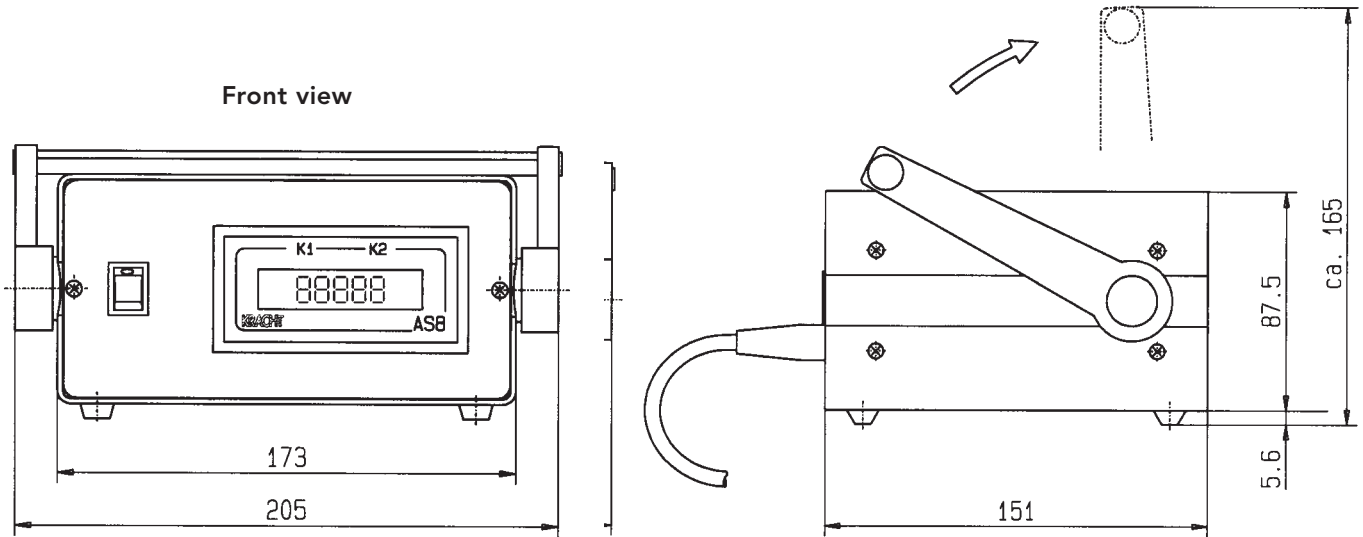

Dimensions in mm

Rear view with RS 232

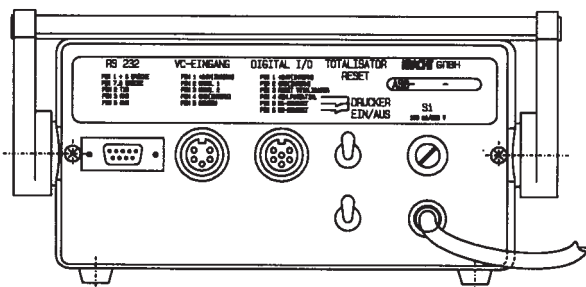

Rear view with analogue output

