

Certified according to DIN EN ISO 9001

Technical Datasheet



HM...R

Turbine Flow Meters
with Female Inch Threads

Application

Turbine flow meters serve to accurate measurement of continuous and discontinuous flow rate values. This turbine flow meter is most suited for liquids with low viscosity, such as for example water, solvents, cleaning agents and light oils. The large range of different pipe connections and structural sizes allows using these flow meters in various applications and in various industrial sectors.

Principle and Design

The turbine flow meters KEM are indirect volume counters built on the principle of using the counter with the Woltmann turbine impeller. The energy coming from the flow of the liquid sets in motion a centrally and rotatably mounted rotor. The number of the rotor revolutions is directly proportional to the volumetric liquid flow. The speed of rotation of the turbine rotor is contactlessly sensed through the wall of the flow meter body. The impulses generated by each turbine blade correspond to a certain accurate volumetric flow of the measured medium.

The number of pulses for a certain period of time corresponds to the value of the medium flow rate expressed, for example, in litres per minute. The lightweight turbine wheel allows quick response to changes in the value of the medium flow rate (< 50 m/s). The flow meters with wing rotor are less sensitive to dirt compared to common turbine flow meters.

Applications

- Tap and demineralised water
- Fuels
- Liquefied gases
- Pharmaceutical liquids
- Fuel oil
- Solvents
- Hydraulic oil

Features

- Short response time (> 50 ms)
- Dynamic measuring system
- High resolution
- Temperature: -196°C to +350°C
- Pressure: up to 630 bar
- Robust carbide bearings

Technical Data

Type	Measuring range, l/min		K-Factor, pulses/l ¹⁾		max. Pressure, bar	Frequency, in Hz ¹⁾		Weight, kg
			≥ 1cst	> 8cst		≥ 1cst	> 8cst	
HM 009 RP*	0.03	to 0.8	139,000	-	630	1,900	-	0.5
HM 003 R*	0.3	to 1.5	32,000	32,500	630	1,100	-	0.3
HM 004 R*	0.5	to 4	24,000	19,500	630	1,170	-	0.3
HM 005 R*	0.8	to 6	17,800	17,800	630	1,740	-	0.4
HM 006 R*	1.2	to 10	11,000	11,000	630	2,100	-	0.4
HM 007 R*	2.0	to 20	5,200	5,200	630	1,800	-	0.5
HM 009 R*	3.3	to 33	1,900	4,200	630	1,080	2,200	0.5
HM 011 R*	6.0	to 60	1,300	2,730	400	1,350	2,700	0.5
HM 013 R*	8.5	to 85	900	1,900	400	1,300	2,600	0.9
HM 019 R*	15	to 150	310	650	400	925	2,000	1.3
HM 028 R*	30	to 360	155	320	315	960	2,000	2.6
HM 030 R*	35	to 400	130	270	315	1,000	1,800	2.9

1) The data on K-factors and maximum frequencies are average values at 1mm²s. The numbers of pulses and frequencies at higher viscosities may vary. Exact values can be found in individual calibration records.

* Detailed type code on request

General	
Linearity	± 1.0% of actual flow (1 mm ² /s)
Repeatability	± 0.2%
Viscosity range	0.8 to 100 mm ² /s
Materials	Housing: as per DIN 1.4305 (SS303); 1.4571 (SS316 Ti); 1.4404 (SS316 L) Weehls: as per DIN 1.4122; 1.4460 (SS329) Bearing: Carbide, sapphire (HM* RP)
Medium temperature	-196°C to +350°C (higher temperatures on request)
Dimensions	See drawing (page 4)

Pickup Selection

Criteria	Type	VTE *	WT */ WI*	VIE *	IF */ VIEG	VTC *	VTB *	TD *	VHE *	FOP *
		Drilling type ¹⁾	E	E	E	E	E	E	E	D
Medium temperature	≤ +70°C									
	≤ +120°C					X	X		X	X
	≤ +150°C	X	X	X						
	≤ +350°C				X					
EX-Approval		X	X	X	X	X	X			X
Frequency output		X	X	X	X	X			X	X
Dual frequency output										
Analogue output 4 - 20 mA			X			X				
Forward / backward recognition										
Display Vorort						X	X			
Linearization			X			X				
Supply 12 - 24 V		X	X	X	X	X			X	
Supply battery							X			X
Interface			X			X				

1) Drilling types: E: single pickup / D: dual pickup / F: FOP-pickup

* Ordering code (please see separate datasheet)

Dimensional Drawings (mm) - HM...R

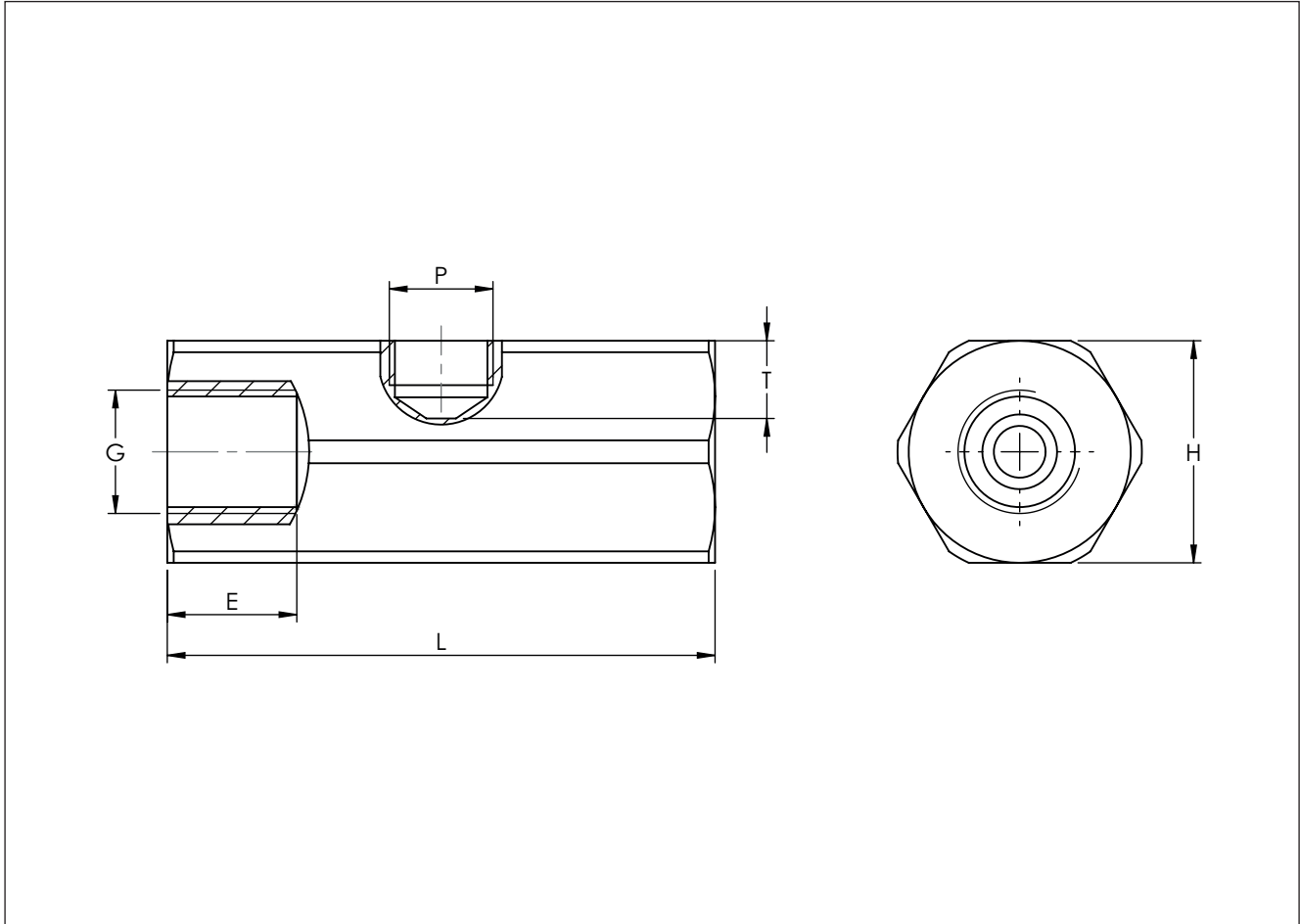

HM Type	E	G	L	H	P ¹⁾	T ²⁾
HM 003 R*	12.5	G1/4"	60	30	E	12
HM 004 R*	12.5	G1/4"	60	30	E	12
HM 005 R*	12.5	G3/8"	70	30	E	11
HM 006 R*	12.5	G3/8"	70	30	E	11
HM 007 R*	12.5	G3/8"	74	30	E	10
HM 009 R*	12.5	G3/8"	79	30	E	9
HM 009 RP*	12.5	G3/8"	79	30	E	9
HM 011 R*	12.5	G3/8"	86	30	E	8
HM 013 R*	16.5	G3/4"	97	41	E	13
HM 019 R*	18.5	G1	125	46	E	12
HM 028 R*	22.5	G1 1/2"	161	60	E	15
HM 030 R*	22.5	G1 1/2"	181	60	E	14

1) See "Pickup Selection" table (page 3)

2) Please notice: total height is calculated by adding up the height (H) and the height of the pickup (separate data sheet) and subtract the bore hole depth (T)

* Detailed type code on request

KEM Headquarter

Liebigstraße 5
85757 Karlsfeld
Germany

T. +49 8131 59391-0
F. +49 8131 92604

info@kem-kueppers.com

KEM Service & Repairs

Wetzeller Straße 22
93444 Bad Kötzting
Germany

T. +49 9941 9423-0
F. +49 9941 9423-23

info@kem-kueppers.com



*More distributors & partners can be found at:
www.kem-kueppers.com*

Your local partner:



www.kem-kueppers.com
info@kem-kueppers.com