

Certified according to DIN EN ISO 9001

## Technical Datasheet



VTC / VIC local display  
with integrated frequency- and analogue output

## Description

Compact Local Display unit with integrated carrier-frequency amplifier and temperature sensor for measuring volumetric flow.

All necessary measuring results and parameter for the application could directly be viewed on the VTC / VIC graphic display and changed by using the 4 soft keys.

Depending on the selected control mode (ext. drive, medium temperature, fixed allocation) the VTC / VIC is equipped with the feature improving the measuring accuracy by using 3 linearization databases, which are going to linearize the measuring signal.

Alternatively this function can be used with an USB or HART interface. It creates the possibility to save the input and archiving of parameter and their measuring results. During a pure loop-powered function mode (4-20 mA) the actual value (flow) will be digitalized on a dimensional current loop based on the programming.

In case the VTC / VIC will be connected in a three-wired function mode the LCD backlight will be activated and an additional programmable carrier-frequency amplifier output will be available. The 360° rotatability combined with the tilted 25° front display of VTC / VIC are going to grant a good handling and reading precision in different installation conditions.

Depending on the version the electrical connection could either be a M12 flange plug or a screw terminal, which emerges after opening the front cover.

### Features (version dependent)

- Ex-Approval
- 360°C turnable housing
- Temperature measurement
- 3 x 20 points linearisation
- Graphic display
- Fast setup
- Integrated interface
- Programming and visualisation via KEM „Easy Control“ possible
- Normalized frequency output
- Control inputs
- 2 Status-LEDs

## Technical Data

General	
Display	Intelligent LCD grafik display 132*32 dot view 15*50 mm
Backlight	yellow/green (not for NAMUR or EX available)
Operation	4-keys
Frequency range	VTC: 1-3.000 Hz (typical 0,5 to 5.000 Hz) VIC: 7-3.000 Hz (typical 5 to 5.000 Hz)
Ambient temperature	-20 to +120°C for VTC (distance between flow meter and amplifier > 25 mm) -20 to +150°C for VIC (distance between flow meter and amplifier > 65 mm)
Media temperature	-20°C to +50°C
Electrical connection	Version K: screw clamping strips for the cable gland (M20*1.5) Version 8: M12 plug connector (A-coded)
Connection	Version dependent (see wiring diagramm)

EMC	according to EN 61000-6-4 and EN 61000-6-2
Ex-Approval	ATEX  II 2G Ex ia IIC T4 Gb in preperation
Analogue output	
Type	4-20 mA, 2-wire (passive)
Supplier	15 to 30 V
Load	< 400 Ohm (at 24 V)
Resolution	12 Bit
Temp.Drift	< 100 ppm/K
Linearity	± 0.05% F.S.
Sensor material	Stainless steel 1.4104 (AISI 430 F)
Pulses frequency output	
Number	1
Versions	Version N: NAMUR according to DIN19234 Version P: Push/Pull (Imax 20 mA Ub max 30 V)
Programmable function	a) direct frequency b) normal frequency (1.2 - 1000 Hz) c) divider with programmable pulse time d) batch e) limit (actual value or temperature)
Temperature sensor (VTC only)	
Measuring range	0°C up to +150°C
Accuracy	± 0.5% of actual flow
Housing	
Sensor housing material	Stainless steel 1.4104 (AISI 430 F)
Housing material	Aluminium
Turnable display	360°
Weight	400 g
Dimmensions	see attachment
Protection class	IP 65 (higher on request)
Inputs	
Number	2 (1 for version with cable gland and Push Pull output)
Level	active high at Uin > 3 V related to PIN 3
Internable resistance	3.3k
Programmable function	Totalizer reset, Hold, switch to linearisation tables

## Dimensional Drawing (mm)

Connection version 8:

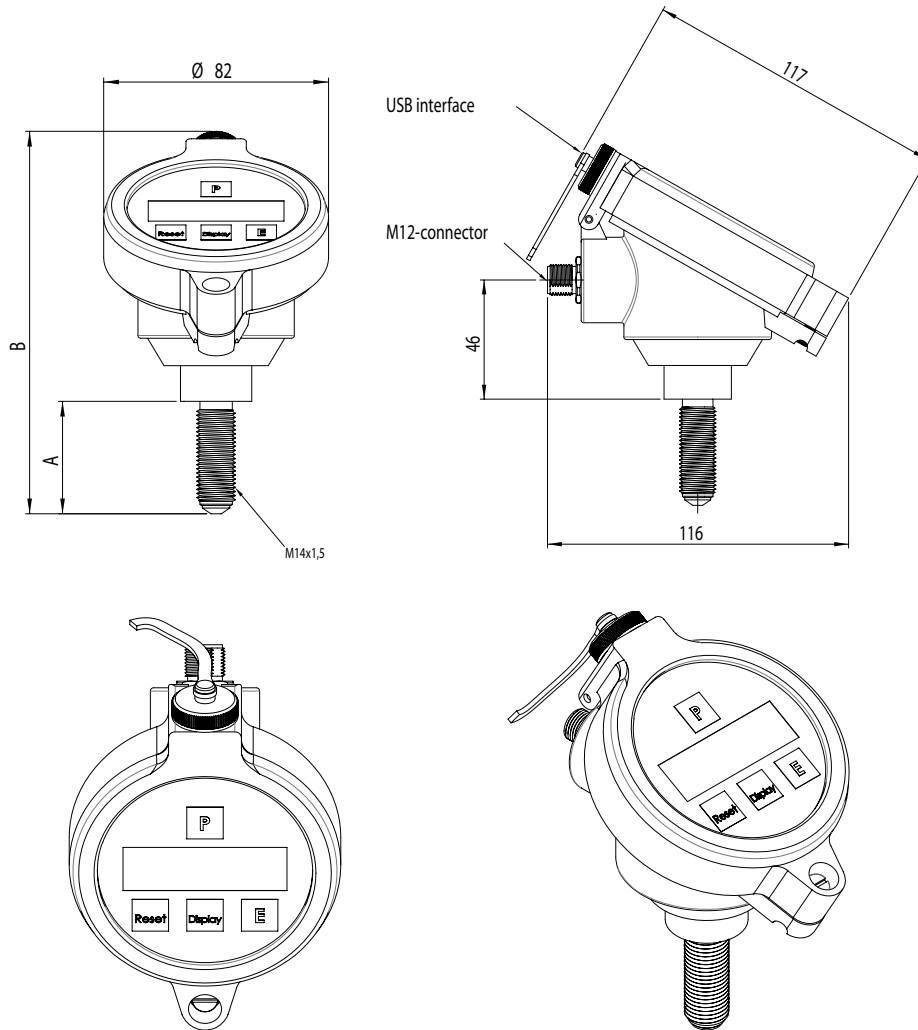

Sensor type	A	B
K or R	42	139
L or S	76	173

**Dimensional Drawing (mm)**

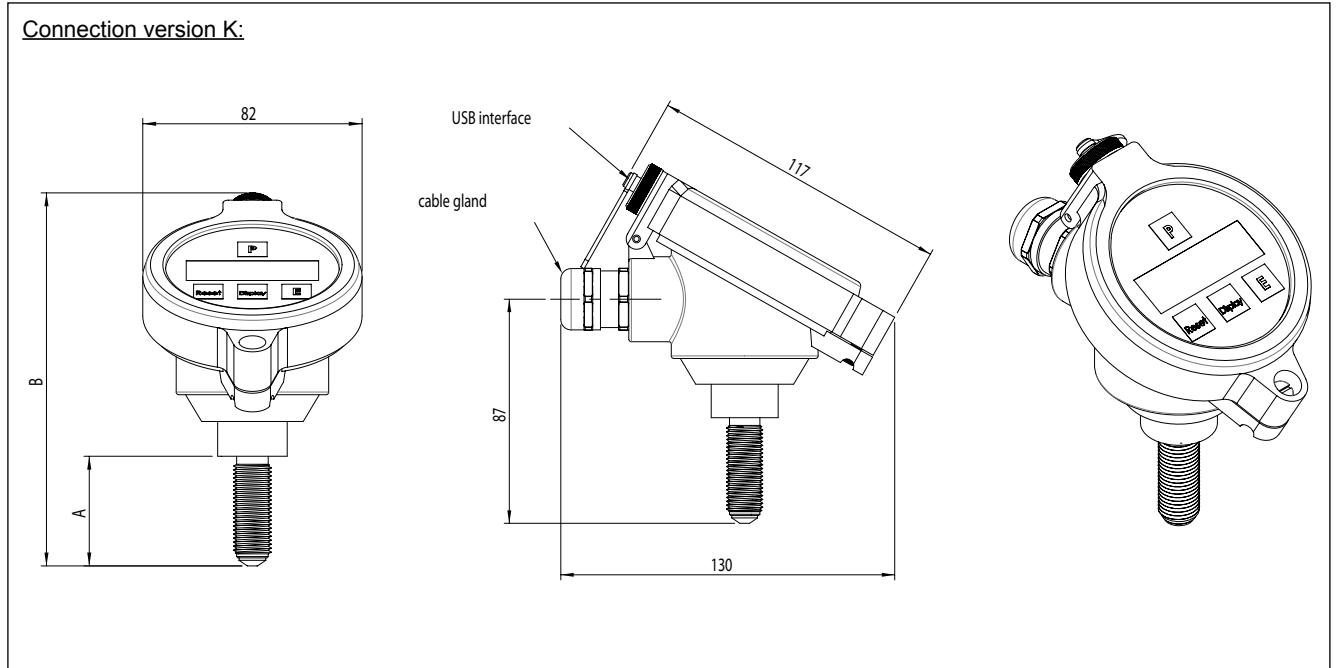

Sensor type	A	B
K or R	42	139
L or S	76	173

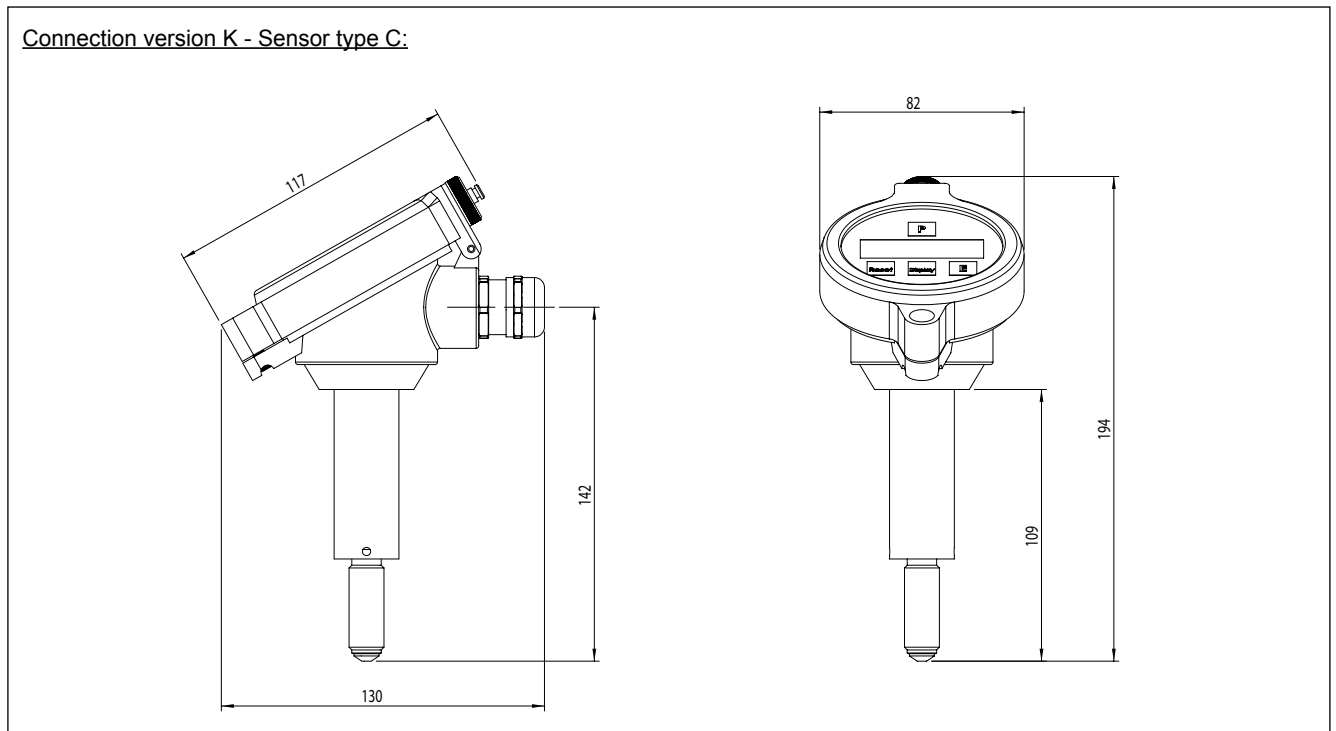

## Wiring Diagram VTC / VIC

with push/pull output ( Ex and no Ex )

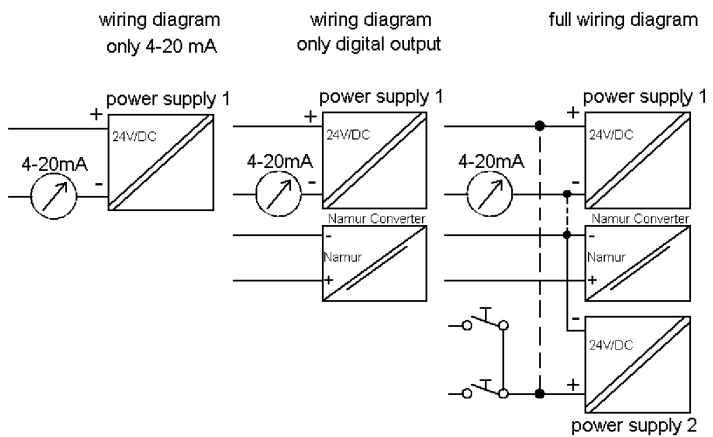
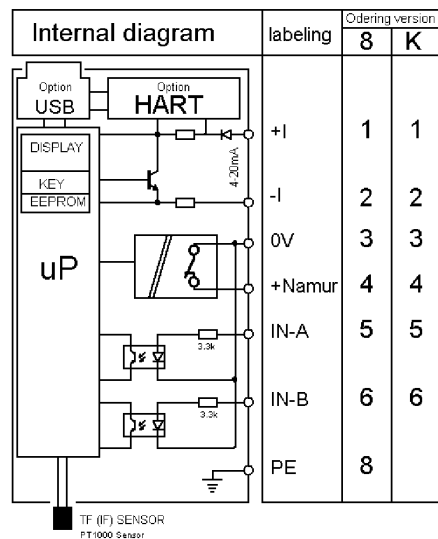
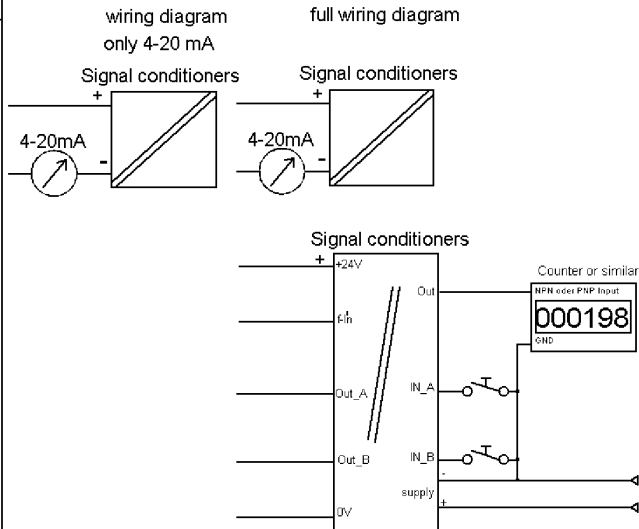
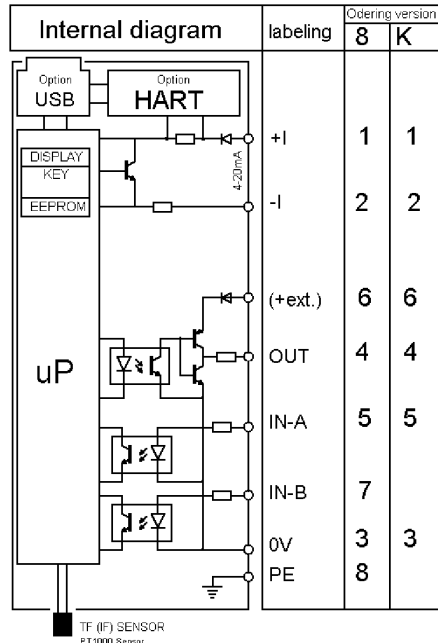

Note: connect " - - - " if you use only power supply 1

Note:

- Always supply pin 1 and 2.
- When the V\*C \*\*\*\* - Ex please follow the related rules for hazardous areas.
- No backlight for Ex versions or versions with NAMUR available.

## Ordering Information VTC / VIC

**A - B - C - D - E - F**  
**V\*C - K - 8 - H - P - Ex**

### Example

#### F = Ex-proof

Ex = Ex-Version Ex i (no backlight for Ex)  
 Exn = for zone II 3G

#### E = Digital Output

P = Push / Pull output  
 N = NAMUR output

#### D = Interface

H = HART-Interface  
 U = USB-Interface (do not use in hazardous areas!)  
 N = KEM Interface

#### C = Connection version

K = Cable gland  
 8 = 8 pin connector

#### B = Mechanical sensor

K = short version for ZHM 02 - ZHM 04 and HM-Series  
 L = long version for ZHM 02 - ZHM 07 and HM-Series  
 R = short version for ZHM 01, SRZ-Serie and LFM-Series  
 S = long version for ZHM 01, SRZ-Serie and LFM-Series  
 C = long version for HMC-Series

#### A = Pickup-System

T = Carrier frequency  
 I = Inductive

## Installation Examples



# Contact

## KEM Headquarter

Liebigstraße 5  
85757 Karlsfeld  
Germany

T. +49/8131/ 59 39 1-0  
F. +49/8131/ 92 60 4

[info@kem-kueppers.com](mailto:info@kem-kueppers.com)

## KEM Service & Repairs

Wetzeller Straße 22  
93444 Bad Kötzting  
Germany

T. +49/9941/ 94 23 0  
F. +49/9941/ 94 23 23

[info@kem-kueppers.com](mailto:info@kem-kueppers.com)

*More distributors & partners can be found at:  
[www.kem-kueppers.com](http://www.kem-kueppers.com)*

Your local partner:



[www.kem-kueppers.com](http://www.kem-kueppers.com)  
[info@kem-kueppers.com](mailto:info@kem-kueppers.com)