

Certified according to DIN ISO 9001

Manual



VTC / VIC Local Display

with integrated Temperature Measurement,
Analog and Digital Output

SW-Version

Main: V02.12

Manual-Revision: 002

1	GENERAL INFORMATION.....	5
1.1	FEATURES.....	5
1.2	SAFETY.....	5
1.2.1	<i>General Safety</i>	5
1.2.2	<i>Safety Requirements for Ex installations</i>	5
1.2.3	<i>Warnings in this manual</i>	6
1.3	ORDERING CODES AND ACCESSORIES.....	6
1.3.1	<i>Ordering Code</i>	6
1.3.2	<i>Accessories</i>	6
2	GETTING STARTED.....	7
2.1	UNPACKING.....	7
2.2	OPERATING ELEMENTS.....	7
2.2.1	<i>Operating elements Front Side</i>	7
2.2.2	<i>Operating Elements Back Side</i>	8
2.3	PIN ASSIGNMENTS.....	9
2.3.1	<i>Pin assignment connector 8 pin</i>	9
2.3.2	<i>Pin assignment screw type terminal</i>	9
2.4	QUICK START.....	10
2.4.1	<i>First Operation</i>	10
2.4.2	<i>Manual Control</i>	11
3	INSTALLATION.....	12
3.1	MECHANICAL INSTALLATION.....	12
3.2	ELECTRICAL INSTALLATION.....	12
3.2.1	<i>Electrical Installation VTC / VIC with screw type terminals</i>	13
3.2.2	<i>Power Supply and Grounding</i>	13
3.2.3	<i>Operation as passive 4-20 mA sensor</i>	14
3.2.4	<i>Operation with current and frequency output</i>	14
3.2.5	<i>Operation with frequency output only</i>	16
3.2.6	<i>Operation as indicator without outputs</i>	17
4	MANUAL OPERATION.....	18
4.1	POWER ON SEQUENCE AND PRINCIPLES OF MANUAL CONTROL.....	18
4.2	MEASURING MODE.....	19
4.2.1	<i>Function of the keys</i>	19
4.2.2	<i>Display selection</i>	19
4.2.3	<i>Resetting the batch value</i>	19
4.2.4	<i>Info Menu</i>	19
4.3	CONTROL MODE.....	20
4.3.1	<i>Function of the keys</i>	20
4.3.2	<i>Submenus in the Main Menu</i>	20
4.3.3	<i>DISPLAY Menu</i>	21
4.3.3.1	FLOW DISPLAY menu.....	21
4.3.3.2	TOTAL DISPL menu.....	23
4.3.3.3	DENS DISPLAY menu.....	23
4.3.3.4	TEMP DISPLAY menu.....	24
4.3.4	<i>SETUP Menu</i>	24
4.3.4.1	K-FACTOR menu.....	25
4.3.4.2	CUT-OFF menu.....	26
4.3.4.3	FLOW-FILTER menu.....	26
4.3.4.4	DENSITY menu.....	26
4.3.4.5	DIG.OUT menu.....	27
4.3.4.6	ANALOG-OUT menu.....	31
4.3.4.7	CTL-INPUT menu.....	32
4.3.4.8	LINEAR menu.....	32
4.3.4.9	KEY-RESET menu.....	32
4.3.4.10	SAVE DATA menu.....	33
4.3.4.11	RECALL DATA menu.....	33
4.3.5	<i>LINEAR Menu</i>	34

4.3.6	I/O TEST Menu	35
4.3.7	SERVICE Menu.....	36
5	REMOTE OPERATION	37
5.1	STANDARD INTERFACE	37
5.1.1	Electrical connections.....	37
5.2	USB INTERFACE.....	38
5.2.1	Electrical connection	38
5.3	HART.....	38
5.3.1	Electrical connection for HART.....	38
5.3.2	HART Interface Protocol.....	38
6	SERVICE AND MAINTENANCE	39
6.1	MAINTENANCE	39
6.2	SERVICE	39
6.3	CALIBRATION	39
6.3.1	Calibrating the current output	40
6.3.2	Calibrating the temperature measurement	41
6.3.3	Reset the TOTAL counter.....	41
6.4	TROUBLE SHOOTING	41
7	LISTINGS	42
7.1	WARRANTY	42
7.2	CERTIFICATIONS AND COMPLIANCES.....	42
7.3	TECHNICAL DATA	44
7.3.1	Dimensional Drawings	46
7.4	WEEE AND ROHS	48
7.5	LIST OF FIGURES	48
7.6	ADDRESSES.....	48

1 General Information

1.1 Features

The VTC / VIC are compact, intelligent local displays with built in carrier frequency (VTC) or inductive (VIC) pickup.

They can be used as passive 4-20mA sensors (2 wire operation) or with auxiliary supply also as sensors with frequency or switch output.

They can be adjusted to any flow meter, as the K- factor is freely settable. The selectable dimensions include virtually all worldwide used dimensions.

The 20 point linearization of the input signal provides the possibility to display also strongly nonlinear signals with high accuracy.

Via a temperature sensor in the pickup tip the medium temperature can be measured.

As a standard the VTC / VIC (except the versions with NAMUR output) are equipped with a proprietary interface which can be converted to USB via the external converter CON.USB.WT. As an option USB and HART interfaces are available.

For fast test setups in the lab and easy setup of individual parameters, the PC based control SW EasyControl for WINDOWS ® XP, VISTA and 7 is available free of charge.

1.2 Safety

1.2.1 General Safety

All statements regarding safety of operation and technical data in this manual will only apply when the unit is operated correctly in accordance with this manual.

The data for Ingress Protection will only apply when all connectors are capped properly with the corresponding counterpart with the same or better IP rating. Cable glands must be populated with cables with the specified diameter and closed properly.

During operation all openings of the housing must be closed unless otherwise noted in this manual.

All connections to the load and to the supply must be made with shielded cables unless otherwise noted in this manual. This unit must be grounded.

This unit must be supplied by a safety approved power supply with outputs which comply with Safety Extra Low Voltage (SELV).

As a protection against fire in the positive supply a fuse with a current rating not higher than the current carrying capacity of the cable used is required.

National and international standards regarding electrical installation have to be adhered to.

The devices described in this manual may only be connected and operated by authorized and qualified personnel.

1.2.2 Safety Requirements for Ex installations

When the VTC / VIC are to be used in hazardous areas, suitable isolation amplifiers or barriers have to be used.

When using long cables make sure that the maximum inductances and capacitances for the respective voltage or gas group are not exceeded.

The USB interface must not be used in hazardous areas.

Only Ex certified units may be used in hazardous areas.

1.2.3 Warnings in this manual

NOTE:

Notes provide important information for the correct usage of the equipment. If the notes are not observed, a malfunction of the equipment is possible.

WARNING!

Warnings provide very important information for the correct usage of the equipment. Not observing the warnings may lead to danger for the equipment and to danger for health and life of the user

1.3 Ordering Codes and Accessories

1.3.1 Ordering Code

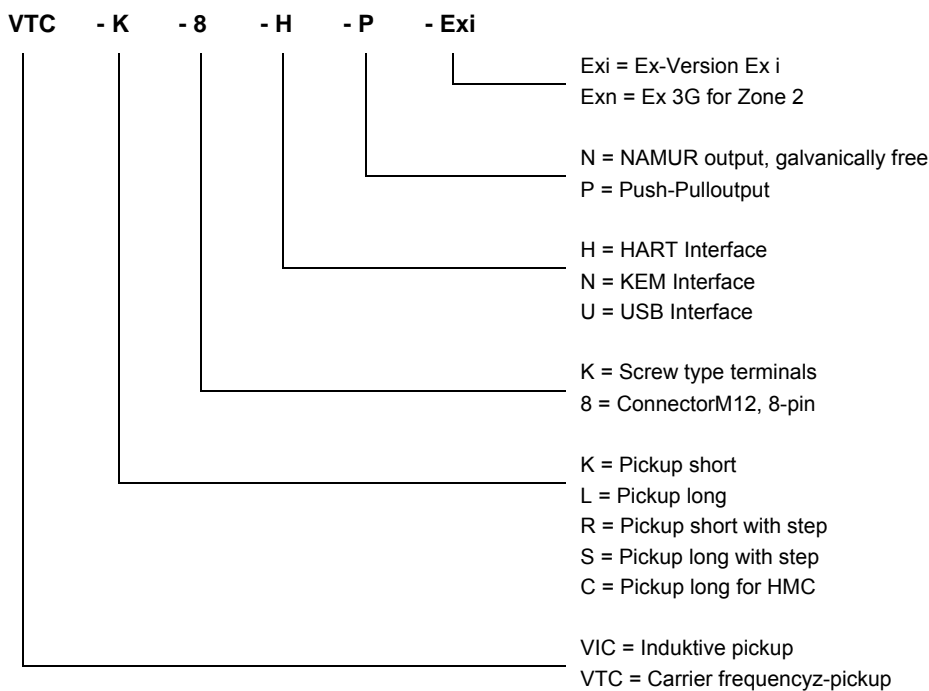

1.3.2 Accessories

Ordering Code	Description
CON.USB.WT	Interface converter to USB
Upon request	Connector M12; type 713
Upon request	cable, 8-pin, black, 5 m with connector M12

2 Getting started

2.1 Unpacking

Verify that you have received the following items:

VTC / VIC
This manual

2.2 Operating Elements

2.2.1 Operating elements Front Side

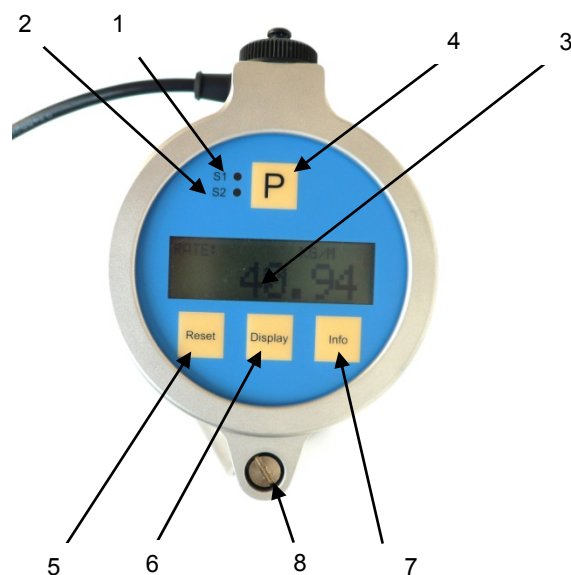

Fig. 1: Operating elements front side

- 1 = LED „S1“, lights green, if the control output is in the active state
- 2 = LED „S2“, lights red, if the loop current exceeds 20mA
- 3 = Display
- 4 = Pushbutton „P“, opens a selected menu and/or confirms the settings
- 5 = Pushbutton „RESET“, Measuring: resets the batch counter, Setup: Softkey
- 6 = Pushbutton „DISPLAY“, Measuring: changes the display, Setup: Softkey
- 7 = Pushbutton „INFO“, Measuring: opens the Info menu, Setup: Softkey
- 8 = Screw for opening the top cover

2.2.2 Operating Elements Back Side

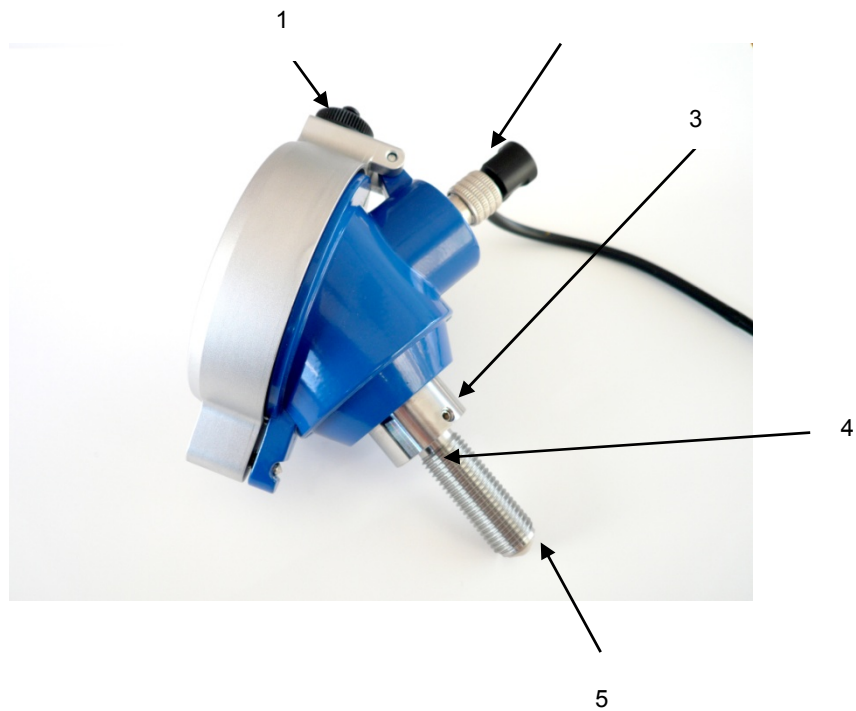
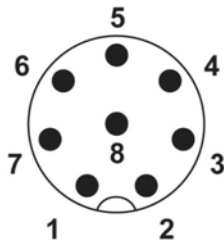

Fig. 2: Operating elements side view

- 1 = USB interface (option)
- 2 = I/O connector
or cable gland
- 3 = Screw for fixing the display orientation
- 4 = Sensor fixing nut
- 5 = Sensor tip with M14 thread

2.3 Pin Assignments

2.3.1 Pin assignment connector 8 pin



- 1 +I (positive supply 2- and 3- wire operation)
- 2 -I (current output, negative supply with 2 wire operation)
- 3 Ground terminal with 3 wire operation
- 4 Frequency output
- 5 Control and communication input 1
- 6 +24V supply for 4 (PP) / Control input 2 (NAMUR)
- 7 Control input 2 (PP) / n.c. (NAMUR)
- 8 PE

For an exact description of all inputs and outputs see chapter 3.2.

2.3.2 Pin assignment screw type terminal



- 1 +I (positive supply 2- and 3- wire operation)
- 2 -I (current output, negative supply with 2 wire operation)
- 3 Ground terminal with 3 wire operation
- 4 Frequency output
- 5 Control and communication input 1
- 6 +24V supply for 4 (PP) / Control input 2 (NAMUR)

For an exact description of all inputs and outputs see chapter 3.2.

2.4 Quick start

WARNING:

As for safety and accuracy reasons many precautions must be taken, read chapter 3 carefully before installing the unit!

In case the unit has only to be operated for testing or learning purpose, the following connections have to be made (see chapter 3.2):

- Screw – if required – the VTC / VIC into the meter
 - Connect the 24V DC supply
 - The frequency and analog outputs as well as the interface may be connected as well, if those features are required
With built in USB interface the VTC / VIC can be operated from USB as well, if no output signal is required.
-

WARNING:

If the unit is connected to a bigger system, for your personal safety connect the protective ground as well!

2.4.1 First Operation

Make sure that all mechanical and electrical connections are made properly.

Switch on the power supply.

After the power up sequence the display shows the preselected values.

If there is a flow (or as rotating tooth wheel), the corresponding flow will be calculated according to the set k-factor and will be displayed.

The display view can be altered by pressing the key "Display".

The device status information can be viewed by pressing the key "Info" for 3 seconds.

If the function is activated, the BATCH reading can be reset to zero by pressing the key "Reset".

For entering the SETUP menu press "P" for 3 seconds.

2.4.2 Manual Control

In the manual control menus all configurations can be made. The submenus, in which the functionality of the VTC / VIC or any factors can be altered, are protected by passwords.

The menu itself is self-explaining, the function of the softkeys (5, 6, 7) is indicated in the display above the pushbutton.

For entering the manual control menu press the pushbutton “P” (4) until the display shows:



```
MAIN MENU
DISPLAY
DOWN  UP  EXIT
```

Select the desired submenu with “UP” or “DOWN” and confirm with “P” (4).

If the submenu is protected by password, the display shows:

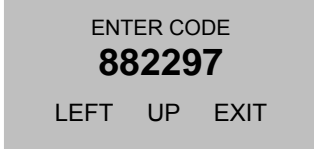

```
ENTER CODE
882297
LEFT  UP  EXIT
```

Change the indicated number with the softkeys “LEFT” and “UP” (6) to “882207” and confirm with “P” (4).

Select the desired submenu or function with “NEXT” or “UP” and “DOWN” and confirm with “P” (4).

Every setting must be confirmed with “P” (4) for storing the setting or with “EXIT” for exiting without storing.

For leaving any menu press “EXIT” (7) several times until the measuring menu reappears.

3 Installation

NOTE

All installations must only be executed by qualified personnel.

3.1 Mechanical Installation

Screw the sensor tip of the VTC / VIC by hand (without tools) into the M14x1.5 sensor thread of the meter until you reach the stop.

WARNING

Too much force will damage the sensor tip!

Turn backwards the VTC / VIC by 45°.

Fix the VTC / VIC with the fixing nut.

NOTE:

If you turn backwards the VTC / VIC by more than 90°, the flow might not be measured correctly. If you do not turn back the VTC / VIC, the sensor tip might be damaged with strong temperature changes.

For adjusting the display orientation, open the 2 headless screws with a 2mm Allan key by about 1 turn.

Rotate the display to the desired position and reattach the headless screws.

3.2 Electrical Installation

Make sure that the unit is properly mounted before making the electrical connections.

NOTE:

Switch off the power supply before making changes at the electrical installation.

This unit must be grounded.

The VTC / VIC requires a regulated DC power supply of 24V nominal and works properly over a supply range of 15V to 30V.

For connecting the VTC / VIC, shielded cables must be used. The shield should be connected to the PE terminal. If in bigger systems the shield must not present a DC connection for avoiding high ground loop currents, make the ground connection of the shield via a capacitor of e. g. 100nF.

WARNING

Improper grounding and shielding may lead to bad EMC behavior or danger to your health!

NOTE

Make sure that all cable and wires are connected and fixed properly before applying power to the VTC / VIC.

3.2.1 Electrical Installation VTC / VIC with screw type terminals

Prepare the cable for installation:

- Separate the single conductors for about 8cm
- Strip the end for about 7mm and cover it with a cable end sleeve
- Connect if necessary a stranded wire to the shield

Open the holding screw in the top cover and open the top cover carefully.

Feed the cable through the cable gland.

Connect the wire according to chapter 3.2.2 to 3.2.6.

Adjust the position of the cable in the cable gland in that way that the single conductors remain short but free of tension and fix the cable in the cable gland.

Close the top cover and reattach the retention screw.

3.2.2 Power Supply and Grounding

The power supply input of the VTC / VIC has an internal diode against reverse polarity.

All pins of the connector are RF blocked to the case (PE) by 2.2nF capacitors. For proper operation therefore the case must be grounded. The grounding might be done via the cable shield or via the meter.

NOTE:

In bigger systems the cable shield must not be the only PE connection.

For best RF behavior the power supply should be grounded at 1 point in the system

3.2.3 Operation as passive 4-20 mA sensor

For operating the VTC / VIC as passive 4-20mA sensor, only pin 1 and 2 are to be connected.

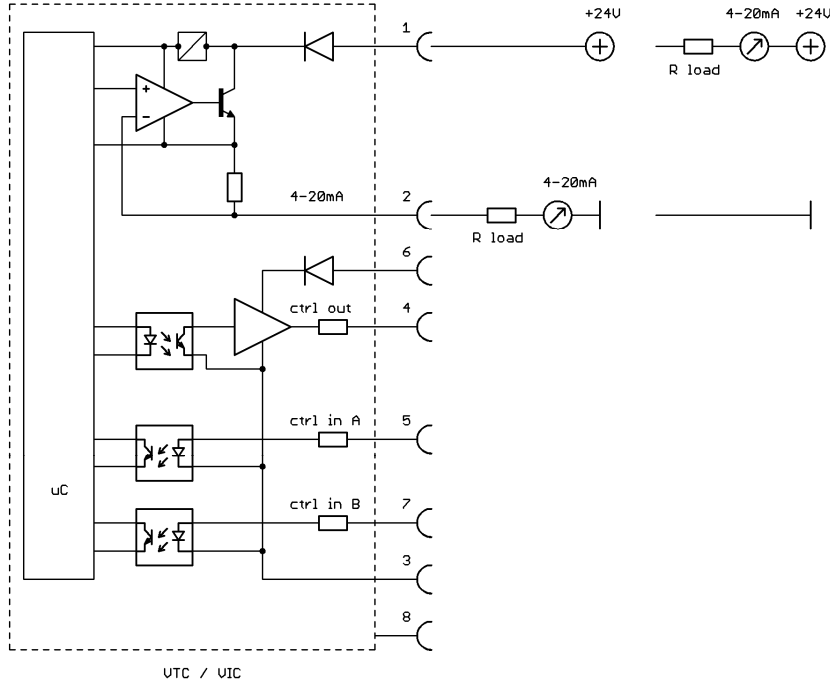

Fig. 3: Wiring diagram passive 4-20mA sensor

The maximum load resistance (input resistance of the ammeter plus protective resistor) can be calculated as

$$R_{Lmax} = (U_B - 15V) / 20.5mA$$

The load resistor plus the ammeter can be connected in the positive or in the negative supply rail.

With 2 wire passive operation there is no display backlight.

Versions with NAMUR frequency output are to be connected in the same way.

3.2.4 Operation with current and frequency output

If with versions with push-pull output pin 3 is connected to the positive supply and pin 3 to GND, the push pull frequency output is powered up as well and the backlight lights up.

Versions with NAMUR output do not have a separate power supply terminal and do not provide a backlight.

For the supply of the analog output (pin 1 and 2) and the digital output (pin 3 and 6), according to the requirement, separate supplies or a common supply might be used.

For the maximum load resistance refer to chapter 3.2.3

NOTE:

If pin 1 and 2 are left open, the μC of the VTC / VIC will not operate at all!

Versions with screw type terminal do not have terminals 7 and 8.

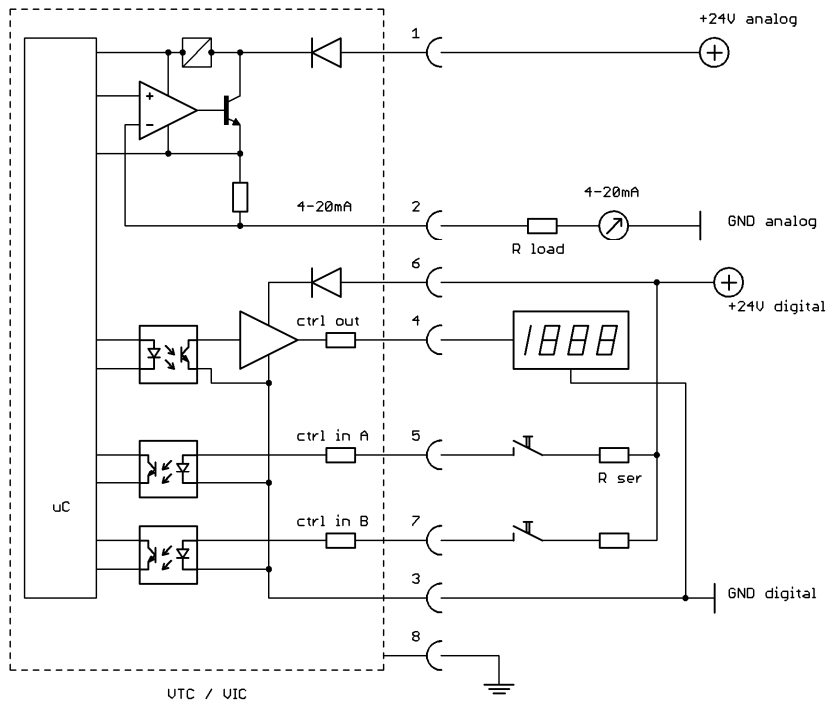

Fig. 4: Wiring diagram 3 wire operation with analog and frequency output, push-pull output

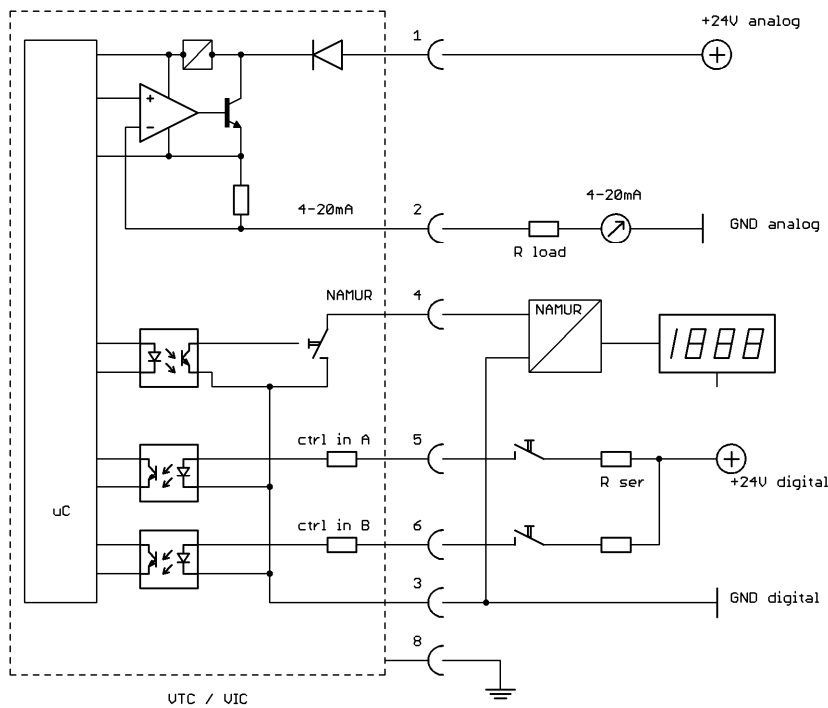

Fig. 5: Wiring diagram 3 wire operation with analog and frequency output, NAMUR output

The digital output is an asymmetrical push pull output stage with $R_1 = 720 \Omega$ and $R_2 = \Omega$.

The high and low output voltages can be calculated as:

$$V_{\text{high}} = V_{\text{supply}} - 0.5V - 720\Omega * I_{\text{load}}$$

$$V_{\text{low}} = 470\Omega * I_{\text{load}}$$

The output is short circuit prove.

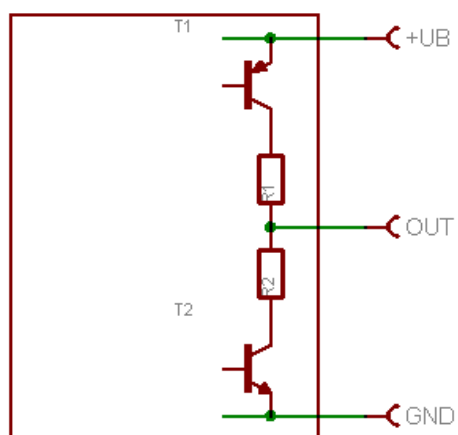

Fig. 6: Digital output stage of the VTC / VIC

3.2.5 Operation with frequency output only

Connect the VTC / VIC according to the diagram.

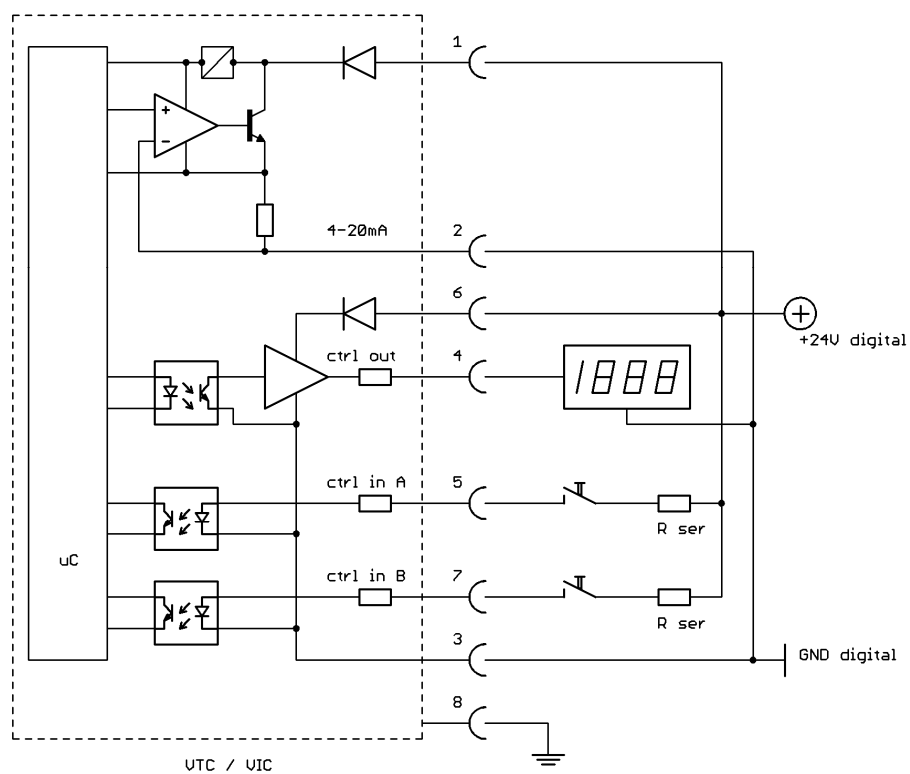

Fig. 7: Wiring diagram 3 wire active with frequency output only, push-pull output

For the description of the frequency output refer to chapter 3.2.4.

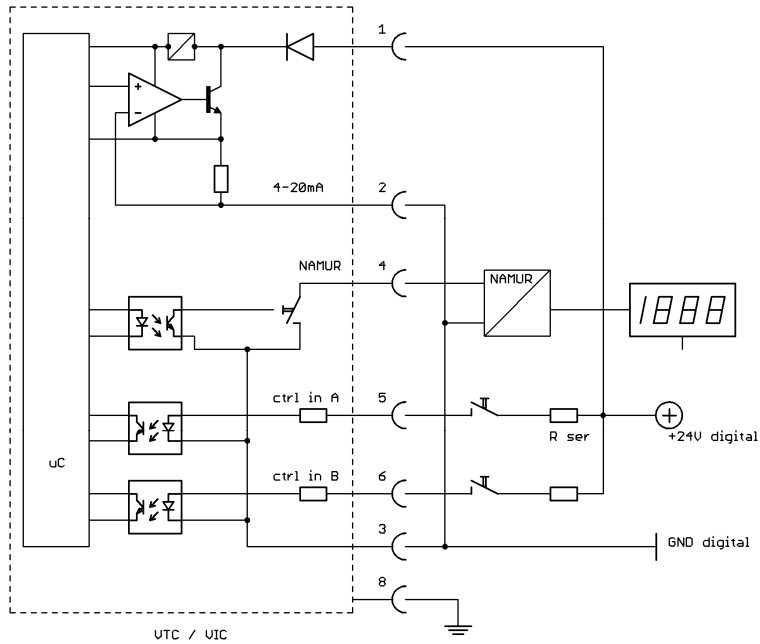

Fig. 8: Wiring diagram 3 wire active with frequency output only, NAMUR output

In this operating mode the current output can be set to “4mA constant”, which reduces the power dissipation in the VTC / VIC.

NOTE:

If pin 1 and 2 are left open, the μC of the VTC / VIC will not operate at all!
 Versions with screw type terminal do not have terminals 7 and 8.

3.2.6 Operation as indicator without outputs

If the VTC / VIC is to be used just as an indicator only, connect terminal 1 to the positive supply and terminal 2 to the supply GND.

In this operating mode the current output can be set to “4mA constant”, which reduces the power dissipation in the VTC / VIC.

If additionally pin 3 is connected to GND and pin 6 to the positive supply, the backlight lights up (versions with push-pull output only).

4 Manual Operation

4.1 Power On Sequence and Principles of Manual Control

For about 2 second the display shows the device name and the SW version:



VTC
SW-NR:02.02

Now the VTC / VIC switches to the measuring mode, displaying the last active screen, e.g.:

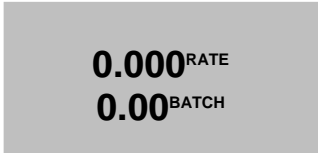

0.000^{RATE}
0.00^{BATCH}

In manual control the VTC / VIC is menu driven and provides 2 operational modes, the “Measuring Mode” and the “Control Mode”.

In the measuring mode the display shows the preselected measured values and all 4 pushbuttons have the function printed on them. The switch over between the different measuring displays can be made at any time without interrupting the measurements.

If a value to be displayed exceeds the display range, the display shows “OVERFLOW”.

In the control mode the 3 pushbuttons below the display have varying functions. The actual function is indicated in the display, just above the pushbutton.

In the control menu all necessary settings can be made.

The control menu contains the submenus “DISPLAY”, “SETUP”, “LINEAR” (only units with built in linearization), “I/O-TEST” and “SERVICE”.

In the menu “DISPLAY” the local display of the unit can be adapted to the actual needs. All settings made in this menu have no influence on the measurements.

In the menu “SETUP” all settings to adapt the unit to the actual needs can be made, like configuring the inputs and outputs.

In the menu “I/O-TEST” all inputs and outputs can be tested after the installation.

In the menu “LINEAR” (linearization) the parameters for the built in linearization can be set.

The menu “SERVICE” allows for calibration of the unit.

For protecting the unit against unintentional changes by unauthorized personnel, the menus “SETUP”, “LINEAR” and “I/O-TEST” are protected by a user password and the menu “SERVICE” by a service password.

4.2 Measuring mode

4.2.1 Function of the keys

In the measuring mode all pushbuttons have a fixed function:

P	Opens the Control Menu if pressed for > 3 seconds
Reset	Resets the batch counter to zero, if the function "KEY RESET" is enabled
Display	Toggles the display between the different screens.
Info	Opens the info menu

4.2.2 Display selection

The VTC / VIC provides the following display:

RATE:

The display shows the actual flow with the selected resolution and engineering unit.

BATCH:

The display shows the BATCH counter with the selected resolution and engineering unit.

TOTAL:

The display shows the TOTAL counter with the selected resolution and engineering unit.

TEMP:

The display shows the actual temperature with the selected engineering unit.

RATE-BATCH:

The display shows the actual flow and the BATCH counter with the selected resolution and engineering unit.

GRAPH 1:

The display shows the flow over the last 30s. 100% equals the value specified for 20mA loop current.

GRAPH 2:

The display shows the actual flow in percent as bar graph and as a number.

For changing from on display to the other just press the pushbutton "Display".

For changing the settings of the displays refer to chapter 4.3.3.

4.2.3 Resetting the batch value

For easy batching in local operation the VTC / VIC provides the possibility to reset the batch value by pressing the pushbutton "Reset".

Resetting is only possible, if the display screen "Batch" is active.

For protecting the unit against unintentional resetting of the batch value, this function can be disabled.

Ex work the function is disabled.

For changing the setting refer to chapter 4.3.4.9

4.2.4 Info Menu

For easy debugging in case of a malfunction of the system, the VTC / VIC provides an info menu for the service personnel. It does not contain information required for normal operation.

For entering the menu press the pushbutton "Info" for about 3 seconds.

For returning to the normal menu press "Display".

4.3 Control Mode

THE VTC / VIC operates normally also if the control menu is activated.

In the control mode the VTC / VIC can be adapted to the individual application. As unintentional changes of the settings might cause problems, some submenus are password protected.

To enter the control mode proceed as follows:

Press "P" until the display shows:



Select the desired submenu with "UP" and "DOWN" and confirm with "P" or skip with "EXIT".

If in the control mode no key is pressed over a longer period, the VTC / VIC automatically returns to the measuring mode.

4.3.1 Function of the keys

In the setup menu some pushbuttons have changing functions, indicated in the display above the pushbutton:

P	Confirms the selection in a list or any kind of inputs If changes get confirmed with "P", they will be used immediately for the calculations
Reset	Performs the indicated function
Display	Performs the indicated function.
Info (EXIT)	Exits the current menu point without altering the original value

4.3.2 Submenus in the Main Menu

In the Main Menu the following submenus are addressable:

DISPLAY:

Presetting the display.

Changes made in this submenu have no influence on the general function as well on the accuracy of the unit.

SETUP:

Adjusting the VTC / VIC to the meter and configuring the inputs and outputs.

This submenu is password protected.

LINEAR:

Setting the parameters for the linearization.

Not available in all units.

This submenu is password protected.

I/O-TEST:

Setting the outputs to defined values and displaying the actual status of the control inputs for testing the electrical connections.

This submenu is password protected.

SERVICE:

Calibrating the current loop.

This submenu is password protected.

4.3.3 DISPLAY Menu

Select in the main menu



Press "P". The display shows



The following submenus are available:

FLOW DISPLAY:

Setting the flow units, the flow decimal point and a flow filter for the display.

TOTAL DISPL:

Setting the total and batch units and the total and batch decimal point.

DENS DISPLAY:

Setting the density units.

TEMP DISPLAY:

Setting the temperature units.

4.3.3.1 FLOW DISPLAY menu

In the submenu "FLOW DISPLAY" the flow dimensions, the flow decimal point and the flow filter for the display can be set.

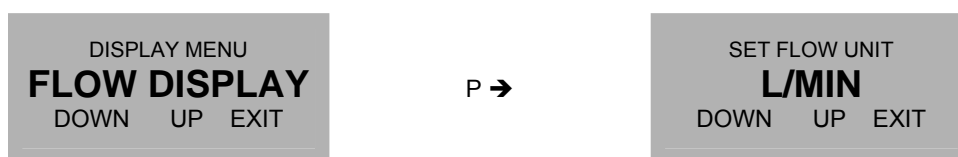

The following units (volume or mass per time) can be selected:

time-Unit Description

S	second
MIN	minute
H	hour
D	day

Volume-Unit Description

CC	cubic centimeter
L	liter
m3	cubic meter
UGAL	US gallon
LOZ	fluid ounce
EGAL	English gallon
BBL	English barrel

Mass-Unit	Description
G	gram
KG	kilogram
LB	pound
OZ	dry ounce
T	metric ton
ST	stone

NOTE:

When mass units are selected, a correct setting of the density (see chapter 4.3.4.4) is required.

Use the keys “UP” and “DOWN” to select setting the engineering unit and confirm with “P” or skip with “E”.

If the units are changed from volume to mass or vice versa, the display shows:

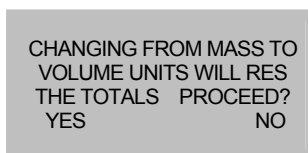

NOTE:

When changing from mass to volume units or vice versa, the total unit will be changed correspondingly.

With every change between mass and volume flow units the batch and the total counter get reset to zero!

When pressing “NO”, the changes will be discarded.

The display shows:

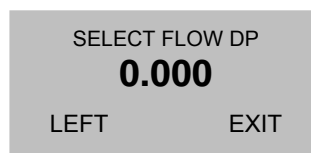

Use the key “LEFT” to select the desired decimal point position and confirm with “P” or skip with “EXIT”.

The display shows



The time constant t is the time the output needs after a jump from x to 0 to go to $x/e = x/2.72$.

Use the keys “UP” and “LEFT” to select the desired time constant and confirm with “P” or skip with “EXIT”.

The display returns to the display menu

4.3.3.2 TOTAL DISPL menu

In the submenu "TOTAL DISPL" the total and batch dimensions and decimal point can be set.

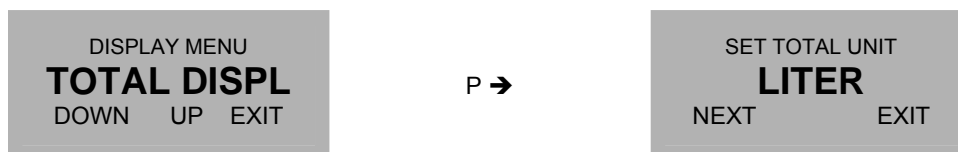

The following units (volume or mass, depending on the selected flow unit) can be selected:

Volume-Unit Description

CC	cubic centimeter
L	liter
m3	cubic meter
UGAL	US gallon
LOZ	fluid ounce
EGAL	English gallon
BBL	English barrel

Mass-Unit Description

G	gram
KG	kilogram
LB	pound
OZ	dry ounce
T	metric ton
ST	stone

Use the key "NEXT" to select setting the engineering unit and confirm with "P" or skip with "EXIT".

The display shows:

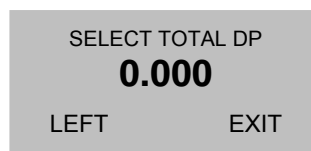

Use the key "LEFT" to select the desired decimal point position and confirm with "P" or skip with "EXIT".

NOTE:

If the value for total gets bigger than the defined display range, the dot will be shifted to the right automatically. If the value gets bigger than 999 999 (more than 6 digits left of the dot), the display shows "OVERFLOW". Select a bigger unit (L instead of CC or M3 instead of L).

The display returns to the display menu

4.3.3.3 DENS DISPLAY menu

In the submenu "DENS DISPLAY" the density dimension can be set.

Setting a density is only required, if mass units (g, kg, t, lb, ...) are to be displayed. If volume units are to be displayed, the density is not used.

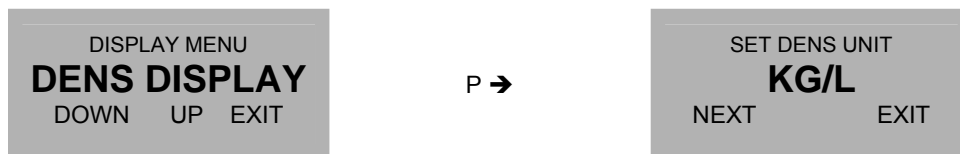

The following units (mass per volume) can be selected:

<u>Unit</u>	<u>Description</u>
G/CC	gram per cubic centimeter
g/L	gram per liter
KG/L	kilogram per liter
LB/FT3	pound per cubic feet
LB/UGAL	pound per US gallon
KG/M3	kilogram per cubic meter

Use the key “NEXT” to select setting the engineering unit and confirm with “P” or skip with “EXIT”.

The display returns to the display menu

4.3.3.4 TEMP DISPLAY menu

In the submenu “TEMP DISPLAY” the temperature dimension can be set.

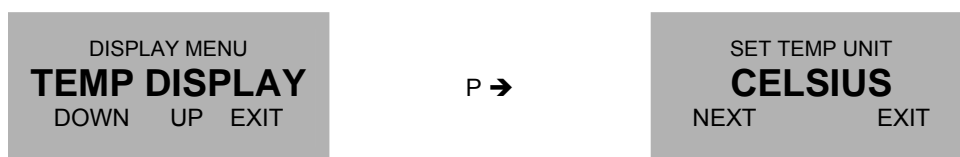

The following units can be selected:

<u>Unit</u>	<u>Description</u>
CELSIUS	Temperature reading in °C
FAHRENHEIT	Temperature reading in F

Use the key “NEXT” to select setting the engineering unit and confirm with “P” or skip with “EXIT”.

The display returns to the display menu

4.3.4 SETUP Menu

Select in the main menu



Press “P”. The display shows

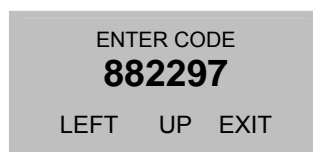

Change the indicated number with “LEFT” and “UP” to 882207 and confirm with “P”.

If a wrong code is entered, the display shows “ERROR” for about 2s and then asks for a new input.

When the correct code is entered the display shows:

```

SETUP MENU
K-FACTOR
DOWN  UP  EXIT
  
```

The following submenus are available:

K-FACTOR:

Defines the relation between the input frequency and the calculated flow.

CUT-OFF:

Sets the cut off frequency for the flow.

FLOW-FILTER:

Sets the filter time constant for the flow.

DENSITY:

Sets the density required for calculating mass and mass flow.

DIG.OUT A:

Configures the digital output A (frequency and control output).

ANALOG-OUT:

Configures the analog output.

CTL-INPUT:

Configures the control input.

LINEAR:

Enables / disables the linearization.

KEY-RESET:

Enables / disables the push button “Reset”.

SAVE DATA:

Stores the current settings to the backup memory.

RECALL DATA:

Recalls the stored settings from the backup memory.

4.3.4.1 K-FACTOR menu

In the submenu “K-FACTOR” the k- factor for the flow calculation can be set.

The k- factor is normally given on the calibration sheet of the meter.

```

SETUP MENU
K-FACTOR
DOWN  UP  EXIT
  
```

P →

```

K-FACTOR (IMP/LITER)
60000.0 IMP/L
LEFT  UP  EXIT
  
```

Use the keys “LEFT” and “UP” to select the desired value and confirm with “P” or skip with “EXIT”.

The display returns to the setup menu.

4.3.4.2 CUT-OFF menu

In the submenu "CUT-OFF" the cutoff frequency for the input can be set.

If the filtered input frequency is below the cutoff frequency, the calculated flow is "0" and consequently all outputs show zero flow and the total and batch value remain unchanged.

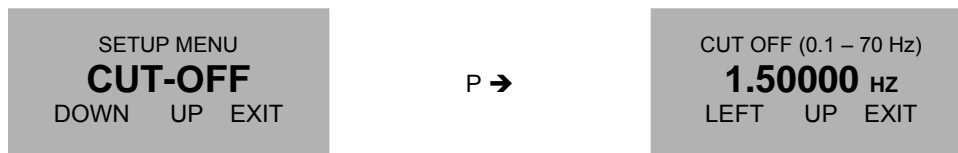

Use the keys "LEFT" and "UP" to select the desired value and confirm with "P" or skip with "E".

The display returns to the setup menu.

4.3.4.3 FLOW-FILTER menu

In the submenu "FLOW-FILTER" the time constant for the flow filter can be set.

The time constant t is the time the output needs after a jump from x to 0 to go to $x/e = x/2.72$.

A rough relation between the time and the filtered flow value after a jump is

Elapsed time	Remaining error (% of the step)
1 * t	30
2 * t	10
3 * t	3
4 * t	1

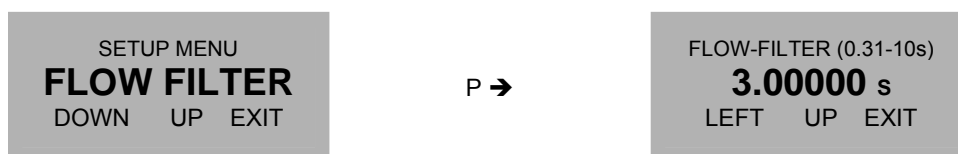

Use the keys "LEFT" and "UP" to select the desired value and confirm with "P" or skip with "EXIT".

The display returns to the setup menu.

4.3.4.4 DENSITY menu

In the submenu "DENSITY" the density value for calculating mass and mass flow can be set.

A correct value for the density is required, if a mass and mass flow is to be measured.

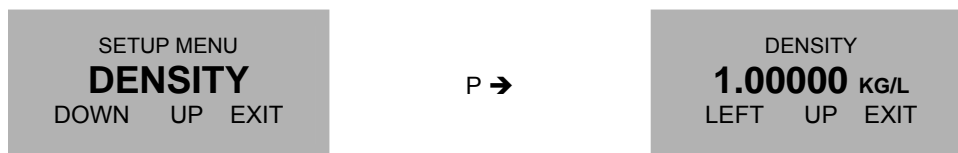

Use the keys "LEFT" and "UP" to select the desired value and confirm with "P" or skip with "EXIT".

The display returns to the setup menu.

4.3.4.5 DIG.OUT menu

In the submenu "DIG.OUT A" the frequency output can be configured.

The following settings are possible:

F-OUT 1:1:

The output frequency equals the input frequency. A linearization will not be regarded.

F OUT NORM:

The output frequency is derived from the calculated flow. If a linearization is active, the output frequency is linearized as well.

The output frequency range is 1.2 to 1000 Hz.

TOTAL COUNT:

For each selected increment of total the output produces a pulse.

FLOW LIMIT:

The output changes its state if the calculated flow exceeds the set limit value.

TEMP LIMIT:

The output changes its state if the temperature exceeds the set limit value.

BATCH LIMIT:

The output changes its state if the batch value exceeds the set limit value.

OFF:

The output is disabled.

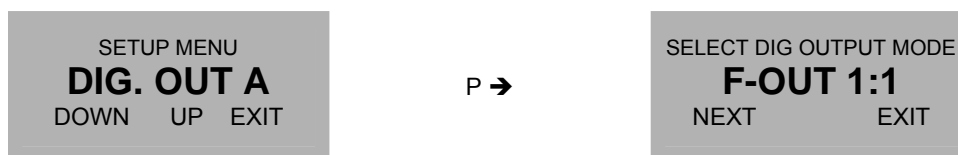

Use the key "NEXT" to select the desired operation mode and confirm with "P" or skip with "EXIT".

F-OUT 1:1:

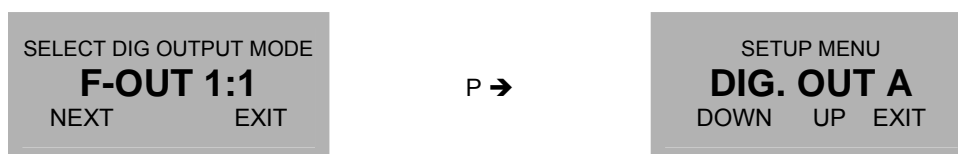

The unit sets the F-OUT 1:1 mode and returns to the setup menu.

F OUT NORM:

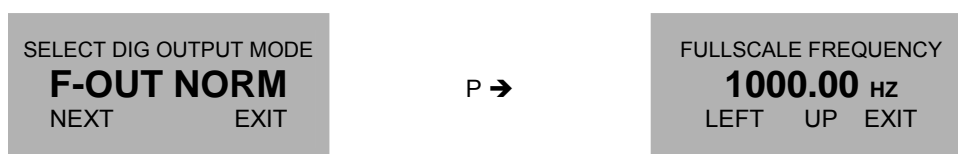

Use the keys "LEFT" and "UP" to select the desired value and confirm with "P" or skip with "EXIT".

NOTE:

The output frequency range is 1.2 to 1000Hz. Calculated frequencies lower than 1.2Hz produce a zero output, frequencies higher than 1000 Hz will be set to 1000 Hz.

The display shows:

```
ENTER FULLSCALE FLOW
10000.0 L/MIN
LEFT  UP  EXIT
```

Use the keys "LEFT" and "UP" to select the desired value and confirm with "P" or skip with "EXIT".

The display returns to the setup menu

TOTAL COUNT:

```
SELECT DIG OUTPUT MODE
TOTAL COUNT
NEXT      EXIT
```

P →

```
INCREMENT VALUE
1000.00 LITER
LEFT  UP  EXIT
```

Use the keys "LEFT" and "UP" to select the desired value and confirm with "P" or skip with "EXIT".

The display shows:

```
ENTER PULSETIME 1-420ms
50.0000 ms
LEFT  UP  EXIT
```

Use the keys "LEFT" and "UP" to select the desired value and confirm with "P" or skip with "EXIT".

The display shows:

```
OUT-STATUS
ACTIVE = HIGH
NEXT      EXIT
```

Active HIGH means that the output is normally low and produces a "HIGH" pulse, active low is the opposite.

Use the key "NEXT" to select the desired operation mode and confirm with "P" or skip with "EXIT".

The display returns to the setup menu

FLOW LIMIT:

```
SELECT DIG OUTPUT MODE
FLOW LIMIT
NEXT      EXIT
```

P →

```
FLOW LIMIT
1000.00 L/MIN
LEFT  UP  EXIT
```

Use the keys "LEFT" and "UP" to select the desired value and confirm with "P" or skip with "EXIT".

The display shows:

ENTER HYSTERESIS

1.00000 %

LEFT UP EXIT

The high going threshold (rising flow) is FLOW LIMIT + HYSTERESIS, the low going is FLOW LIMIT – HYSTERESIS.

With a FLOW LIMIT of 10 l/min and 5% hysteresis, the active going value is 10.5 l/min, the inactive going value 9.5 l/min

Use the keys “LEFT” and “UP” to select the desired value and confirm with “P” or skip with “EXIT”.

The display shows:

OUT-STATUS

ACTIVE = HIGH

NEXT EXIT

Active HIGH means that the output is low for a flow below the threshold and high for a flow above the threshold, active low is the opposite.

Use the key “NEXT” to select the desired operation mode and confirm with “P” or skip with “EXIT”.

The display returns to the setup menu

TEMP LIMIT:

SELECT DIG OUTPUT MODE

TEMP LIMIT

NEXT EXIT

P →

TEMP LIMIT

10.0000 CELSIUS

LEFT UP EXIT

Use the keys “LEFT” and “UP” to select the desired value and confirm with “P” or skip with “EXIT”.

The display shows:

ENTER HYSTERESIS

1.00000 %

LEFT UP EXIT

The high going threshold (rising temperature) is TEMP LIMIT + HYSTERESIS, the low going is TEMP LIMIT – HYSTERESIS.

With a TEMP LIMIT of 90°C and 5% hysteresis, the active going value is 95.5 °C, the inactive going value 85.5 °C.

Use the keys “LEFT” and “UP” to select the desired value and confirm with “P” or skip with “EXIT”.

The display shows:

```

OUT-STATUS
ACTIVE = HIGH
NEXT      EXIT
    
```

Active HIGH means that the output is low for temperatures below the threshold and high for a flow above the threshold, active low is the opposite.

Use the key "NEXT" to select the desired operation mode and confirm with "P" or skip with "EXIT".

The display returns to the setup menu

BATCH LIMIT:

```

SELECT DIG OUTPUT MODE
BATCH LIMIT
NEXT      EXIT
    
```

P →

```

BATCH VALUE
100.000 LITER
LEFT  UP  EXIT
    
```

Use the keys "LEFT" and "UP" to select the desired value and confirm with "P" or skip with "EXIT".

The display shows:

```

OUT-STATUS
ACTIVE = HIGH
NEXT      EXIT
    
```

Active HIGH means that the output is low for a batch below the set "BATCH VALUE" and high for a batch above "BATCH VALUE", active low is the opposite.

Use the key "NEXT" to select the desired operation mode and confirm with "P" or skip with "EXIT".

The display returns to the setup menu

OFF:

```

SELECT DIG OUTPUT MODE
OFF
NEXT      EXIT
    
```

P →

```

SETUP MENU
DIG. OUT A
DOWN  UP  EXIT
    
```

The unit sets the output to OFF and returns to the setup menu.

4.3.4.6 ANALOG-OUT menu

In the submenu "ANALOG-OUT" the 4 – 20 mA output can be configured.

The following settings are possible:

FLOW:

The output current is calculated from the measured flow value. A zero flow gives 4mA, the defined maximum flow gives 20mA.

OFF = 4mA:

The output is set inactive, a connected meter will see 4mA constant current.

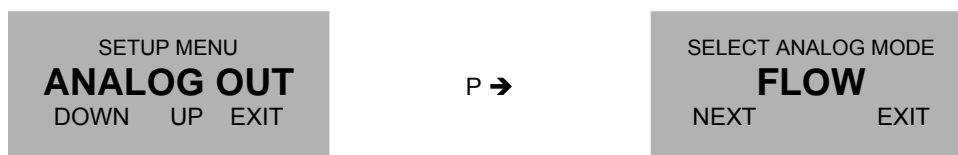

Use the key "NEXT" to select the desired operation mode and confirm with "P" or skip with "E".

FLOW:

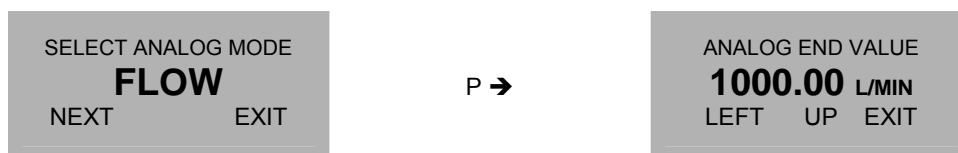

Use the keys "LEFT" and "UP" to select the desired value and confirm with "P" or skip with "E".

The display returns to the setup menu

4mA:

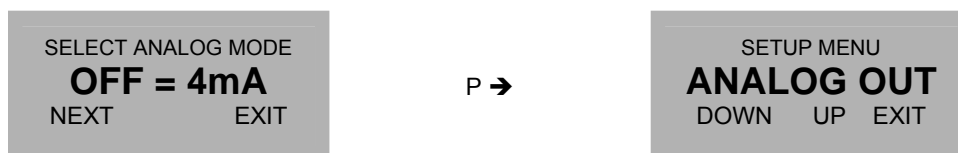

The unit sets the output to 4mA and returns to the setup menu.

4.3.4.7 CTL-INPUT menu

In the submenu "CTL-INPUT" the control input output can be configured.

The following settings are possible:

RES. BATCH:

An active signal at the control input resets the batch counter to zero.

HOLD:

An active signal at the control input stops summing up the total and batch value.

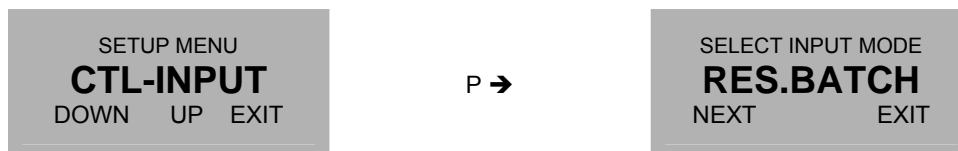

Use the key "NEXT" to select the desired operation mode and confirm with "P" or skip with "EXIT".

The display returns to the setup menu

4.3.4.8 LINEAR menu

In the submenu "LINEAR" can be set, if the linearization is disabled or which of the linearization banks is to be used for linearization.

The following settings are possible:

LIN- BANK n:

Linearization bank n (1 ... 3) is active.

OFF:

Linearization deactivated.

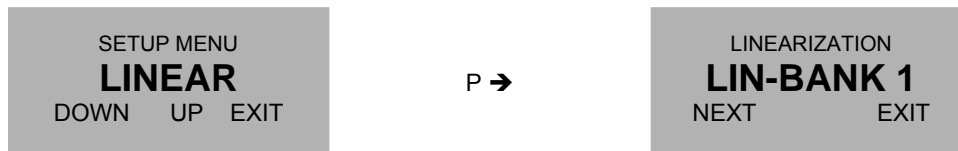

Use the key "NEXT" to select the desired linearization bank or linearization OFF and confirm with "P" or skip with "EXIT".

The display returns to the setup menu

4.3.4.9 KEY-RESET menu

In the submenu "KEY-RESET" the pushbutton "Reset" can be enabled or disabled.

If the pushbutton Reset is active, it can be used to reset the batch counter.

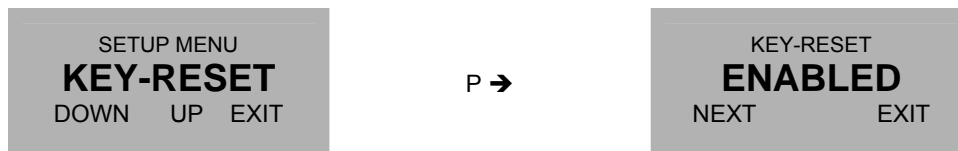

Use the key "NEXT" to enable or disable the pushbutton "Reset" and confirm with "P" or skip with "EXIT".

The display returns to the setup menu

4.3.4.10 SAVE DATA menu

In the submenu "SAVE DATA" the current settings can be stored in a backup memory. The stored settings can be reactivated with "RELOAD DATA" (see chapter 4.3.4.11.).

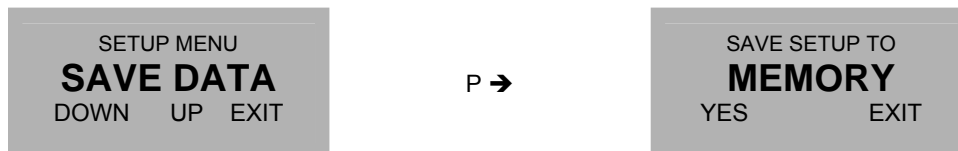

Save the data by pressing "YES" or skip with "EXIT".

If "YES" is pressed, the display counts up for a few seconds and then shows for 2 seconds:

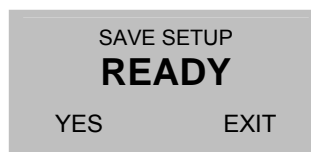

The display returns automatically to the setup menu

4.3.4.11 RECALL DATA menu

In the submenu "RECALL DATA" the stored settings can be reloaded from the backup memory. This is especially useful for returning to a running setup after trying different settings. For storing data in the backup memory refer to chapter 4.3.4.10.

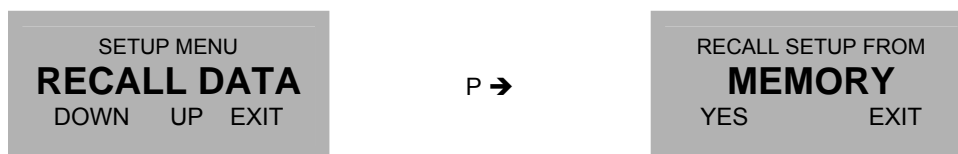

Recall the data by pressing "YES" or skip with "EXIT".

If "YES" is pressed, the display counts up for a few seconds and then shows for 2 seconds:

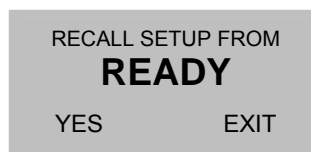

The display returns automatically to the setup menu

4.3.5 LINEAR Menu

In the "LINEAR" menu the data for the built in linearization can be entered.

The data set is organized in 3 independent data banks with up to 20 points each. In the SETUP menu can be selected, which of the banks (1, 2, 3 or none) is to be used for the linearization.

If e.g. a meter has to be used and linearized at 2 or 3 different viscosities, put the linearization values for each viscosity in a different block. In the SETUP menu can be selected, which block has to be used. (see chapter 4.3.4.8)

Select in the main menu

```
MAIN MENU
LINEAR
DOWN  UP  EXIT
```

Press "P". The display shows

```
ENTER CODE
882297
LEFT  UP  EXIT
```

Change the indicated number with "LEFT" and "UP" to 882207 and confirm with "P".

If a wrong code is entered, the display shows "ERROR" for about 2s and then asks for a new input.

When the correct code is entered the display shows:

```
SELECT LIN BANK
LIN BANK 1
NEXT      EXIT
```

Use the key "NEXT" to select the desired linearization bank and confirm with "P" or skip with "EXIT".

The display shows:

```
K-FACTOR (IMP/LITER)
50.0000 IMP/L
LEFT  UP  EXIT
```

Use the keys "LEFT" and "UP" to select the desired value and confirm with "P" or skip with "EXIT".

The display shows:

```
LIN FREQUENCY POINT 01
1.00000 HZ
LEFT  UP  EXIT
```

Use the keys "LEFT" and "UP" to select the desired value and confirm with "P" or skip with "EXIT".

The display shows:

```

LIN ERROR POINT 01
1.00000 %
LEFT  UP  EXIT

```

Use the keys “LEFT” and “UP” to select the desired value and confirm with “P” or skip with “EXIT”.

The sequence goes on with the points 2 to 20.

If $n < 20$ points are to be entered, set for the linearization point $n+1$ the frequency to “0”.

If the frequency “0” is entered or point 20 is set, the display shows:

```

***  READY  ***
THE LINEARIZATION
VALUES ARE PROGRAMED
NOW

```

After 2 second the display automatically returns to the main menu.

4.3.6 I/O TEST Menu

In the “I/O TEST” menu the inputs and outputs as well as the external wiring can be tested.

Select in the main menu

```

MAIN MENU
I/O TEST
DOWN  UP  EXIT

```

Press “P”. The display shows

```

ENTER CODE
882297
LEFT  UP  EXIT

```

Change the indicated number with “LEFT” and “UP” to 882207 and confirm with “P”.

If a wrong code is entered, the display shows “ERROR” for about 2s and then asks for a new input.

When the correct code is entered the display shows:

```

I/O – TEST MENU
F-OUT
NEXT      EXIT

```

Use the key “NEXT” to select the desired test point and confirm with “P” or skip with “EXIT”.

F-OUT:

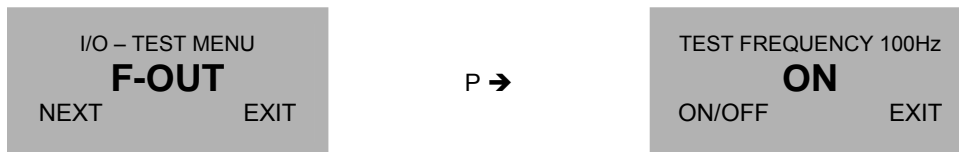

Use the key “ON/OFF” and for switching on and off the 100Hz output frequency or end the test with “EXIT”.
When “EXIT” is pressed, the display returns to the I/O test menu.

ANALOG OUT:

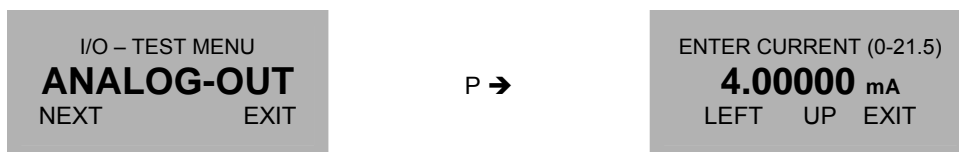

Use the keys “LEFT” and “UP” to select the desired value and confirm with “P” or skip with “EXIT”.
When “P” is pressed the unit sets the selected current, displays OKAY for 2 seconds and then waits for the next current.
If values below 3.8mA are set, the quiescent current (about 3.8mA) will flow.
When “EXIT” is pressed, the display returns to the I/O test menu.

STATUS IN:

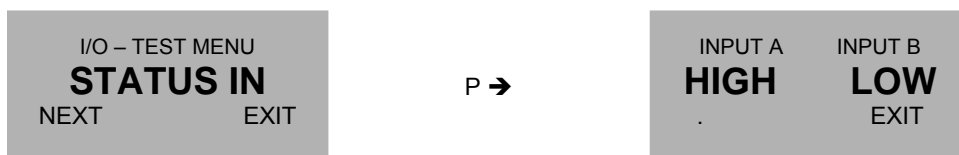

The display shows the current status at the control input.
When “EXIT” is pressed, the display returns to the I/O test menu.

SERIAL:

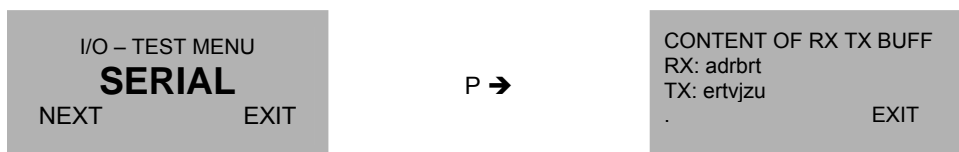

The display shows the current status in the UART send and receive buffers.
When “EXIT” is pressed, the display returns to the I/O test menu.

4.3.7 SERVICE Menu

The “SERVICE” menu is used to calibrate the 4-20mA output.
For a description of the menu refer to chapter 6.3.

5 Remote operation

As a standard the VTC / VIC is equipped with a proprietary KEM interface, which communicates via the frequency output and the control input.

As an option a USB or HART interface is available.

The KEM and USB interface can be used to set up the unit via a PC or to perform simple measuring tasks. For implementing the unit in a bigger system, the HART interface is recommended.

5.1 Standard interface

For communicating via the standard interface the interface converter CON.USB.WT (available as accessory) and the remote control program EasyControl for WINDOWS are required. Easy Control can be downloaded free of charge from our webpage.

NOTE:

Versions with NAMUR outputs do not provide the standard interface!

5.1.1 Electrical connections

Switch off the power supply of the VTC / VIC.

Disconnect the cable from the VTC / VIC.

Connect the cable "WT" of the CON.USB.WT to the VTC / VIC.

NOTE:

For VTC / VIC's with the 8 pin connector or the screw type terminal make an adaptor connecting the pins 1 to 5 of the 5 pin connector of the CON.USB.WT to the pins 1 to 5 of the VTC / VIC. The other pins of the VTC / VIC remain unused.

Ready to use adaptors are available from KEM upon request.

For operating the VTC / VIC by the CON.USB.WT without external power supply switch the internal rotary switch to "INT" and leave the connector "CTL OUT" of the CON.USB.WT open. With that configuration the VTC / VIC will be powered via the USB interface.

Start EasyControl on your PC.

Search the VTC / VIC via "SEARCH DEVICE" and establish the connection via "CONNECT". If the VTC / VIC was selected correctly, its type, serial number and SW version will be displayed in the EasyControl window.

The operation via EasyControl is menu driven and self-explaining. Further information can be found in the EasyControl manual.

5.2 USB interface

For communicating via the USB interface, the remote SW EasyControl (free of charge available from our Webpage) is required.

If the VTC / VIC is connected to the USB interface, is powered via USB. An external power supply is only required, if the current or frequency output is to be used.

NOTE:

As the USB protection cover must be opened for using the USB interface, the ingress protection is reduced to IP20, when the USB cable is connected!

5.2.1 Electrical connection

Switch off the power supply of the VTC / VIC.

Open the USB blind cover.

Connect the USB cable to the VTC / VIC (connector Mini-B) and to the PC.

Start EasyControl on your PC.

Search the VTC / VIC via "SEARCH DEVICE" and establish the connection via "CONNECT". If the VTC / VIC was selected correctly, its type, serial number and SW version will be displayed in the EasyControl window.

The operation via EasyControl is menu driven and self-explaining. Further information can be found in the EasyControl manual.

5.3 HART

The HART interface modulates the 4-20mA current of the VTC / VIC with the data. For using the HART interface, a special HART modem and a special SW are required.

5.3.1 Electrical connection for HART

Connect the VTC / VIC 1 as described in chapter 3.2 and connect the HART communicator between pin 2 and your current meter or between pin 2 and GND, if the current is not to be measured..

Refer to the manual of your HART communicator for the proper connection.

5.3.2 HART Interface Protocol

For getting the newest DD file contact KEM.

6 Service and Maintenance

6.1 Maintenance

The VTC / VIC does not require regular maintenance.

If for the specific application an obligatory calibration is required, refer to the corresponding national regulations for the necessary calibration intervals.

6.2 Service

The VTC / VIC does not contain any user serviceable parts.

In case of malfunction, please contact your nearest dealer or directly KEM.
For the addresses see chapter 7.6.

6.3 Calibration

If necessary the current output of the VTC / VIC can be calibrated.

The menu offers a well the calibration of the temperature measurement, but that is not possible on site, as for the calibration the VTC / VIC needs to be disassembled and a special adaptor is required.

For calibrating the current output, a digital Ampere meter (DAM) with a measuring range up to 22mA, at least 4 ½ digits resolution and an accuracy better 0.05% is required.

For calibrating the VTC / VIC proceed as follows:

Connect the power supply (see chapter 3.2.3).

Press "P" until the display shows:



MAIN MENU
DISPLAY
DOWN UP EXIT

Use the keys "DOWN" or "UP" to select SERVICE and press "P" or quit with "EXIT"

The display shows:

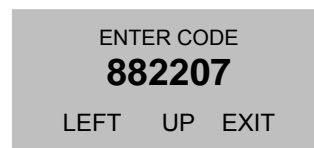

ENTER CODE
882207
LEFT UP EXIT

Change the indicated number with "LEFT" and "UP" to 882208 and confirm with "P" or quit with "EXIT".

If a wrong code is entered, the display shows "ERROR" for about 2s and then asks for a new input.

When the correct code is entered the display shows:

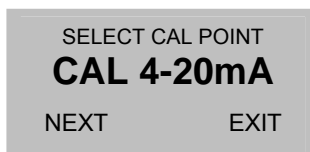

The following submenus are available:

CAL 4-20mA:

Testing the quiescent current, calibrating the output at 4mA and 20mA.

CAL PT1000:

Calibrating the temperature measurement at 0°C and at 150°C.

6.3.1 Calibrating the current output

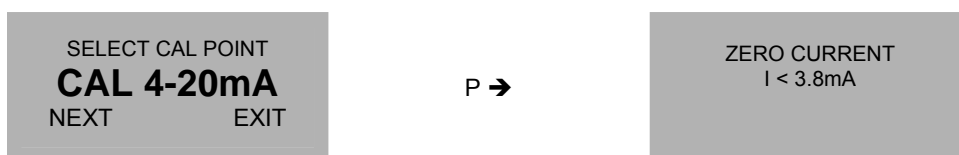

Check the current displayed on the DAM. If the current is higher than 3.8mA the unit has a fault.

Press “P”. The display shows:



Change with “MINUS” and “PLUS” the number in the display, until the DAM shows 4.00 mA.

Press “P”. The display shows:

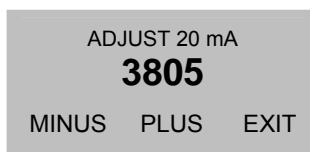

Change with “MINUS” and “PLUS” the number in the display, until the DAM shows 20.00 mA.

Press “P”. The display shows:

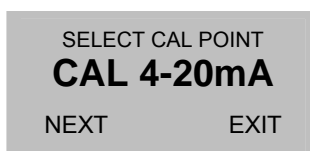

Press “EXIT”. The display shows:

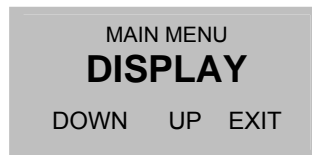

Enter the SETUP menu and store the calibrated values with "SAVE DATA" (see chapter 4.3.4.10).

6.3.2 Calibrating the temperature measurement

The calibration is only possible at KEM, as the unit needs to be disassembled and as a special test adaptor is required.

If you think that a new calibration is required, please contact one of our distributors or KEM directly.

6.3.3 Reset the TOTAL counter

For resetting the TOTAL counter proceed as follows:

- Select the display mask "TOTAL"
- Switch off the power supply
- Press "Reset", switch on the power supply and hold "Reset" pressed, until the power up sequence will be ended.

NOTE:

Changing the engineering units from mass units to volume units or vice versa resets the TOTAL counter as well.

6.4 Trouble shooting

In case the VTC / VIC does not work properly, first check the following items:

No display

All cables properly connected?

→ Connect the missing cables

Power supply switched on?

→ Switch on the power supply

The flow display remains constantly "0"

VTC / VIC mounted properly?

→ Mount the VTC / VIC as described in chapter 3.1

The current remains "0" with correctly indicated flow

Pin 2 shorted to GND?

→ Correct the wiring

The current remains "4mA" with correctly indicated flow

Current output set to "4mA constant"?

→ Correct the setting for the current output, see chapter 4.3.4.6

Output frequency too high or unstable

Most probably EMC problems

Shield and ground properly connected?

→ Connect shield properly.

If necessary, try additional means of grounding and shielding

7 Listings

7.1 Warranty

KEM warrants material and production for a period of 12 months after installation and start up, max. 18 months from delivery date.

7.2 Certifications and compliances

Category	Standards or description	
EC Declaration of Conformity - EMC	Meets intent of Directive 2004 / 108 / EEC for Electromagnetic Compatibility. Compliance is given to the following specifications as listed in the Official Journal of the European Communities:	
	EN 61326 / 2006	EMC requirements for Class A electrical equipment for measurement, control and laboratory use, including Class A radiated and Conducted Emissions ¹ and Immunity ¹ .
	IEC 61000-4-2 / 2009	Electrostatic Discharge Immunity (Performance criterion B)
	IEC 61000-4-3 / 2008	Radiated RF Electromagnetic Field Immunity (Performance criterion B)
	IEC 61000-4-4 / A1-2009	Electrical Fast Transient / Burst Immunity (Performance criterion B)
	IEC 61000-4-5 / 2007 ²	Power Line Surge Immunity (Performance criterion B)
	IEC 61000-4-6 / 2009	Conducted RF Immunity (Performance criterion B)
	IEC 61000-4-11 / 2005 ²	Voltage Dips and Interruptions Immunity (Performance criterion B)
Australia / New Zealand Declaration of Conformity- EMC	Complies with the Radiocommunications Act and demonstrated per EMC Emission standard ¹	
	AS/NZS 2064	Industrial, Scientific, and Medical Equipment: 1992
FCC EMC Compliance	Emissions comply with the Class A Limits of FCC Code of Federal Regulations 47, Part 15, Subpart B ¹ .	

¹ Compliance demonstrated using high-quality shielded interface cables

² Applies only to units with AC mains supply instead of or additional to the SELV supply

Category	Standards or description	
EC Declaration of Conformity – Low Voltage	Compliance is given to the following specification as listed in the Official Journal of the European Communities: Low Voltage Directive 2006/95/EEC	
	EN 61010-1 / 2002	Safety requirements for electrical equipment for measurement control and laboratory use.
U.S. Nationally Recognized Testing Laboratory Listing	UL 61010-1 / 2004	Standard for electrical measuring and test equipment.
Canadian Certification	CAN/CSA C22.2 no. 61010-1-4 / 2008	Safety requirements for electrical equipment for measurement, control, and laboratory use.
Additional Compliance	IEC61010-1 / 2002	Safety requirements for electrical equipment for measurement, control, and laboratory use.
Equipment Type	Test and measuring	
Safety Class	Class 1 (as defined in IEC 61010-1, Annex H) – grounded product	

7.3 Technical Data

Input VTC / VIC	
Type	Carrier Frequency
Frequency range	1 Hz – 3 kHz
Input VIC	
Type	Inductive
Frequency range	7 Hz – 3 kHz
Display and Manual Control	
Display:	Graphic, 132 x 32 dot
Viewing Area:	15mm * 50mm
Backlight	Yellow / green (only 3 wire operation, not with NAMUR outputs)
Status Indicators	2 LED
Programming:	4 softkeys
Analog Output	
Type	4-20 mA, passive
Resolution:	5 μ A
Linearity:	\pm 0.05% of full scale
Temperature drift:	0.05% per 10K
Load:	< 400 Ω (at 24V supply)
Output signal	flow rate
Digital Output	
Type	push pull or NAMUR (DIN19234)
Frequency range	0.5 – 3 000 Hz (mode input frequency) 1.2 – 1000 Hz (mode normalized frequency)
Output Levels PP	<2 V / > 22 V (at 24V supply, no load)
Output Resistance PP	470 / 720 Ω
Output Current PP	20 mA max.
Output level NAMUR	According to DIN19234
Output signal	Input Frequency, normalized Frequency, Total Count, flow limit, batch limit

Control Input	
Type	Opto coupler input
Min pulse duration	25 ms
Input level	< 3V / > 13V
Input Resistance	3.3 kΩ
Temperature Measurement	
Measuring range	-20 ... +120°C
Accuracy	± 1.5°C
Interface	
Type	KEM WT (standard) USB (option) HART (option)
General	
Supply voltage	24 V DC nominal, operating range: 14 – 30V
Reaction time	< 250ms @ input frequency > 5Hz
Connections	Connector M12 or screw type terminal
EMC	according to EN 61000-6-4 and EN 61000-6-2
Ambient temperature	-20 up to +70°C
Medium temperature	-20 up to +120°C
Dimensions	See drawings
Material	Aluminum diecast or stainless steel
Weight	approx. 400g
Protection class	IP 65

7.3.1 Dimensional Drawings

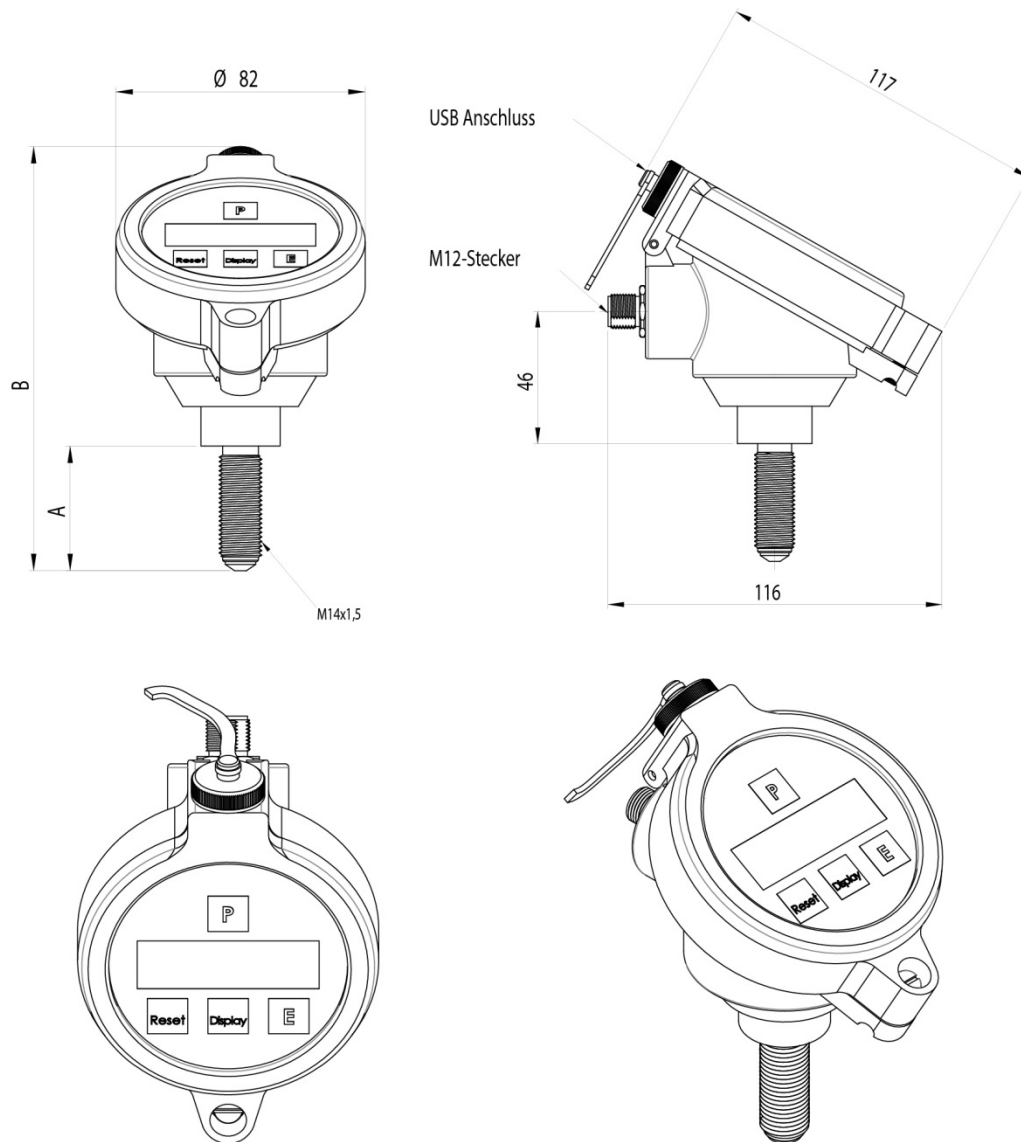

Fig. 9: Dimensional drawings VTC / VIC with connector M12

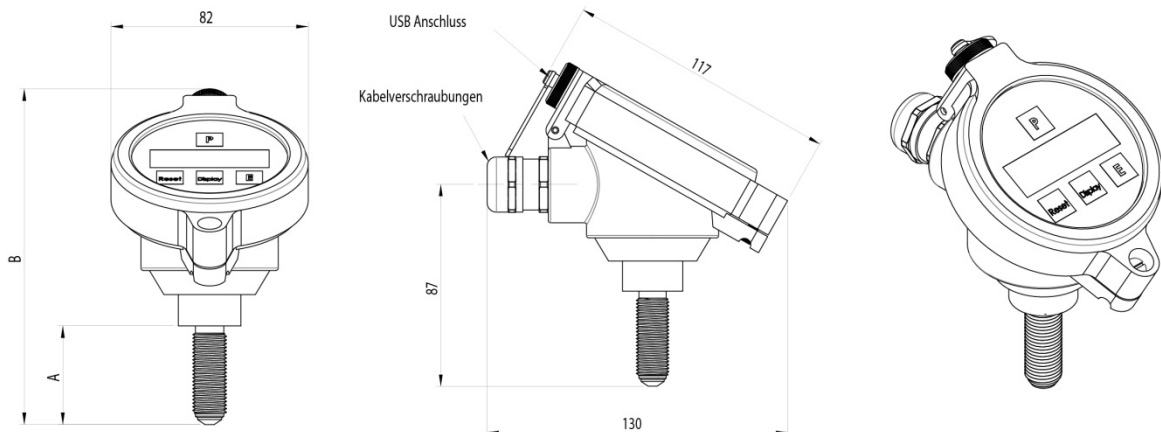

Fig. 10: Dimensional drawings VTC / VIC with screw type terminal

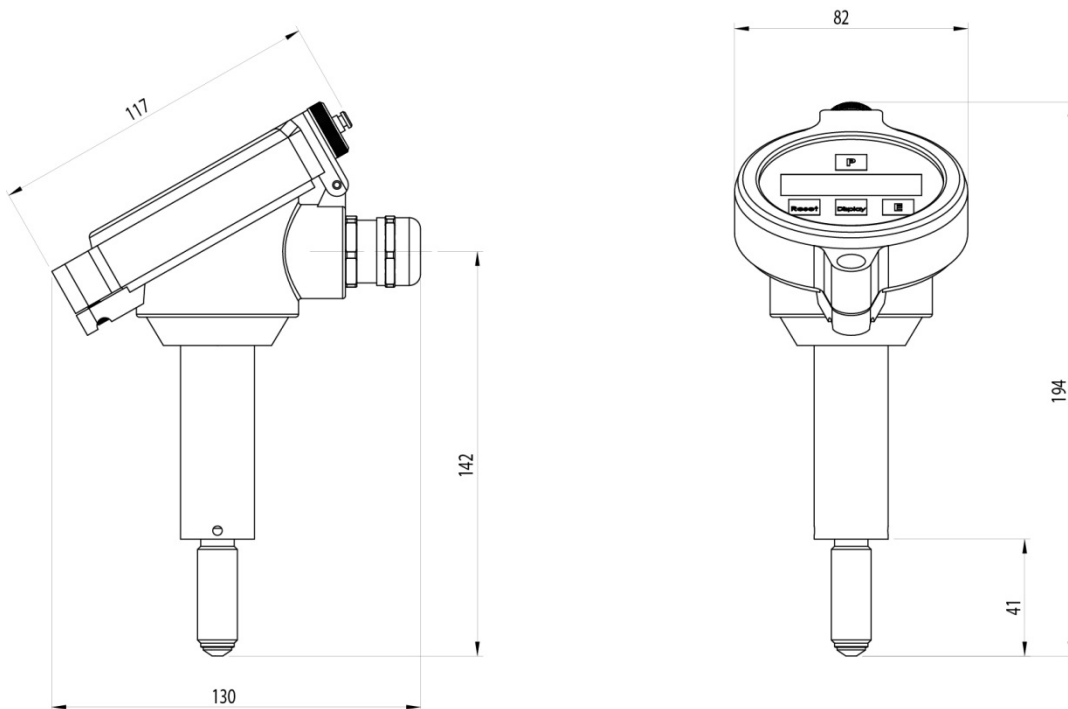

Fig. 11: Dimensional drawings VTC / VIC with screw type terminal and extra long pickup tip

7.4 WEEE and RoHS

The unit described herein is not subject to the WEEE directive and the corresponding national laws.

At the end of life forward the unit to a specialized recycling company and do not dispose it off as domestic waste.

The unit described herein fully complies with the RoHS directive.

7.5 List of figures

FIG. 1: OPERATING ELEMENTS RONT SIDE.....	7
FIG. 2: OPERATING ELEMENTE SIDE VIEW	8
FIG. 3: WIRING DIAGRAM PASSIVE 4-20MA SENSOR.....	14
FIG. 4: WIRING DIAGRAM 3 WIRE OPERATION WITH ANALOG AND FREQUENCY OUTPUT, PUSH-PULL OUTPUT	15
FIG. 5: WIRING DIAGRAM 3 WIRE OPERATION WITH ANALOG AND FREQUENCY OUTPUT, NAMUR OUTPUT	15
FIG. 6: DIGITAL OUTPUT STAGE OF THE VTC / VIC	16
FIG. 7: WIRING DIAGRAM 3 WIRE ACTIVE WITH FREQUENCY OUTPUT ONLY, PUSH-PULL OUTPUT	16
FIG. 8: WIRING DIAGRAM 3 WIRE ACTIVE WITH FREQUENCY OUTPUT ONLY, NAMUR OUTPUT	17
FIG. 9: DIMENSIONAL DRAWINGS VTC / VIC WITH CONNECTOR M12	46
FIG. 10: DIMENSIONAL DRAWINGS VTC / VIC WITH SCREW TYPE TERMINAL.....	47
FIG. 11: DIMENSIONAL DRAWINGS VTC / VIC WITH SCREW TYPE TERMINAL AND EXTRA LONG PICKUP TIP	47

7.6 Addresses

Headquarter:

KEM
Küppers Elektromechanik GmbH
Liebigstraße 5
DE-85757 Karlsfeld
Deutschland

Tel.: +49 81 31/59 39 10
info@kem-kueppers.com
www.kem-kueppers.com

Contact

KEM Headquarter

Liebigstraße 5
85757 Karlsfeld
Germany

T. +49/8131/ 59 39 1-0

F. +49/8131/ 92 60 4

info@kem-kueppers.com

KEM Service & Repairs

Wetzeller Straße 22
93444 Bad Kötzing
Germany

T. +49/9941/ 94 23 0

F. +49/9941/ 94 23 23

info@kem-kueppers.com

*More distributors & partners can be found at:
www.kem-kueppers.com*

Your local partner:



www.kem-kueppers.com

info@kem-kueppers.com