



Küppers Elektromechnik GmbH
Flow Meters

Liebigstraße 2 • D-85757 Karlsfeld • Tel. +49 81 31/59 39 10 • Fax +49 81 31/9 26 04

ZHM Series Installation and Operating Instructions



General

Gear flow meters are positive displacement meters, similar in design to a gear pump. The measuring medium rotates two gears, which are engaged with minimum play. The medium is forced along through closed measuring chambers between gears and housing. The gears, which run idle, lose no power. The r.p.m. of the gears is proportional to the instantaneous flow rate. The gear flow meters are fitted with pickups which will precisely detect the r.p.m. through the body of the meter without contact to the fluid. Pulses per volume unit will finally serve the evaluation (in addition, an analogue signal 4 to 20 mA will be available when using the local display unit VTM).



Evaluation

The K-factor (calibration factor) of the gear flow meter defines the exact pulse rate per litre. The K-factor can be taken from the calibration record, which is supplied with each flow meter. Among others, our calibration records include the following specifications:

- Max. measuring error referring to the instantaneous flow rate
- Max./min. frequency with corresponding flow values
- K-factors for different flow rates
- Average K-Factor valid for the entire flow range

The following equation applies:

$Q = \frac{f \times 60}{K}$	<p>Q = flow rate in litres per minute</p> <p>f = output pulse frequency in Hz</p> <p>K = K-factor of the gear flow meter in pulses per litre</p>
-----------------------------	--

Preparation

Mechanical and electrical installations, start up and maintenance shall only be effected by qualified and authorised personnel. Please make sure that the measuring range of the ZHM cannot be exceeded by more than 20%. Before installation the pipe system has to be purged. Particles must not get into the gear flow meter as they could block the gears. This is particularly important with small sizes ZHM 01–ZHM 02. As a precaution use filters for the measuring medium:

ZHM 01–03: 120 micron
04–05: 200 micron
06–07: 300 micron

Installing the Flow Meter

The gear flow meter should be mounted in flow direction (calibration direction). It can be mounted either horizontally or vertically. The flow direction is indicated by an arrow on the flow meter. The mounting direction is not relevant with reverse flow as in this case the flow meter will have been calibrated for both flow directions.

Our standard gear flow meters are bored to suit Ermeto screwed fittings. No additional sealing is necessary and never should fibrous sealants such as hemp or teflon strip be used when different connections require additional sealing.

Sources of Interference

Magnetic fields and similar sources of interference close to the gear flow meters might affect the pickups. Especially inductive pickups type IF* could react like an antenna. Cables connecting pickup and amplifier and/or evaluation electronics have to be screened, preferably braid-screened.

Vibrating pipes can have a resonance effect on the pickup, especially on inductive types. You may prevent this by fitting flexible hose pipes and avoiding a metallic contact between pickup tip and the bottom of the pickup bore in the gear flow meter. To do so fit the pickup as follows (not applicable for pickups type TD*, HD*; VTD* and FOP which are plugged in and fixed by screws):

- Screw in the pickup handtight without using force
- Slacken pickup by $\frac{1}{4}$ turn
- Tighten the lock nut

Gas bubbles in the system will falsify measuring results. Gear flow meters are pure volumetric meters. When the meter is installed inside hazardous areas it must only be operated completely filled with fluid.

Maintenance

- Gear flow meters have to be purged with an adequate solvent if there is no permanent flow or if the meters will not be used for a long period of time. Purging is particularly important when fluids are likely to harden with particles remaining in the flow meter.
- The calibration of the gear flow meter should be checked after about 8,000 hours of permanent operation.
- The battery of the fibre-optic pickup type FOP 60 is to be exchanged after approx. two years.

Disassembly and Cleaning

Please ensure the line is depressurised, emptied and flushed before disassembly. In case of return shipment to KEM the ZHM must be completely cleaned. This applies in particular for hazardous fluids.

All KEM flow meters are of robust design. Therefore a certain amount of force may be required during disassembly. However, never use undue force, if parts do not separate or components cannot be removed and contact KEM before proceeding.

For cleaning purposes gear flow meters may be disassembled by the user as described below (the figures in brackets refer to the images on page 4). Mark all components with a suitable pen – this will help you to re-assemble them in their original position when re-assembling the meter. O-rings and flat seals must be replaced by genuine KEM spares.

- Remove the pickup (1) from the ZHM. Some types of pickups require you to loosen the hidden fixing screws inside the outer through holes to do so.
- Slacken the Allen screws (2) and unscrew, but keep two opposed screws engaged by 1–2 turns. Now remove all others.



- Hold onto the upper housing (3) and tap the opposing bolts gently with a hammer/mallet to part the upper and lower housing (4) in parallel direction from each other. Do not attempt to use screwdrivers or chisels to split the housing, as otherwise the shafts, bearings and locating pins may be damaged.



- Having separated the housing, remove gears and shafts (5) and clean the parts using a solvent if necessary. Also remove the O-ring (7) and clean the groove except where flat seals (7) are being used with lightweight or cartridge gear flow meters. Remember to replace the seals by genuine KEM spares.

Re-Assembly

- Upon perfect cleaning of the housing, the gears, shafts and the seal may be inserted. The gears must rotate easily to provide proper function in future.
- When assembling the housing, upper and lower part must be kept parallel, utilising the locating pins (6) in their respective holes. The locating pins must under no circumstances be removed or left out. The material codes (see picture) must be placed on top of each other.
- Now tighten the Allen bolts observing the torque figures as listed on page 6.

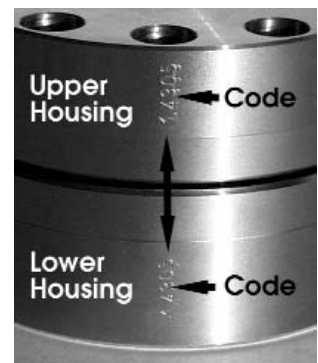

- On completed assembly check the meter to tightness and pressure resistance as per EC directive 97/23/EC.

Finally insert the pickup as follows:

Types VTE*/P, IF*, VTM, IWA, HE*

- Screw in the pickup handtight without using force
- Slacken pickup by 1/4 turn
- Tighten the lock nut

Types TD*, HD* and FOP 60

- Insert pickup in the respective holes
- Tighten the fixing screws in the pickup lid

Standard ZHM

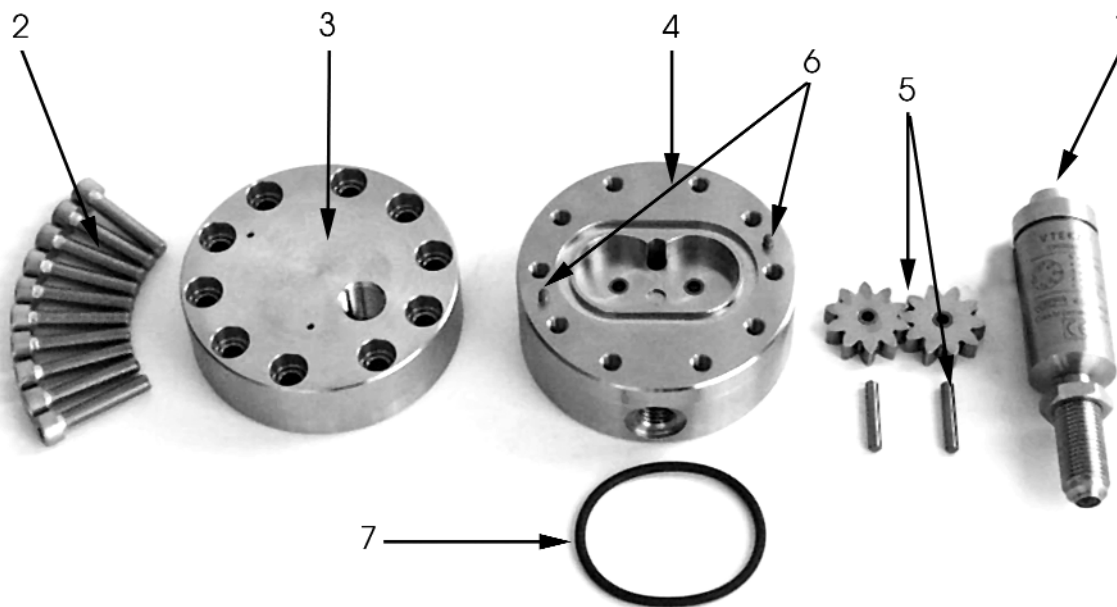

ZHM in Lightweight- and Cartridge Design

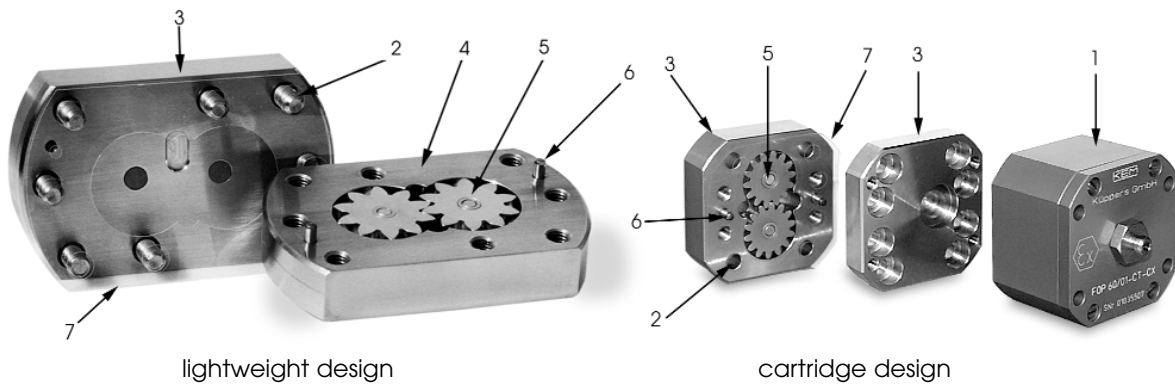

Torque Figures

The following torque figures are valid for tightening threads according to DIN 13. The figures are based on a coefficient of friction of $\mu_{\text{total}} = 0.14$ (new screw without post treatment, non-lubricated).

ZHM...CT Cartridge design

Screw		Torque
M5	Stainless steel	$M_A = 5.9 \text{ Nm}$



ZHM 01 to 03 round standard shape and lightweight design

Screw		Torque
M6	12.9 Steel	$M_A = 18 \text{ Nm}$
M6	Stainless steel	$M_A = 10 \text{ Nm}$
M10	8.8 Steel	$M_A = 49 \text{ Nm}$



ZHM 04/1 and 04 round standard shape

Screw		Torque
M10	12.9 Steel	$M_A = 84 \text{ Nm}$
M10	Stainless steel	$M_A = 49 \text{ Nm}$

ZHM 05 to 06 round standard shape

Screw		Torque
M12	12.9 Steel	$M_A = 145 \text{ Nm}$
M12	Stainless steel	$M_A = 85 \text{ Nm}$



ZHM 07 round standard shape

Screw		Torque
M16	12.9 Steel	$M_A = 365 \text{ Nm}$
M16	Stainless steel	$M_A = 210 \text{ Nm}$

Pickups and Amplifiers

For safe use of pickups/amplifiers please also refer to the "Safety Instructions for Electrical Devices"

Various Pickups are available for gear flow meters. The advantages of the individual types will meet special requirements of the measuring task:

Application and Features	Type	Pin/Terminal
standard fluid temperatures -20°C...+120°C/150°C push pull or open collector output	VTE*/P carrier frequency amplifier with integral pickup	pin 1UB +7 up to 29 VDC pin 2signal push pull pin 30 V/ground pin 4open collector signal (collector) pin 5open collector signal (emitter)
high resolution, reverse flow detection ambient temp.: -20°C up to +50°C fluid temp.: up to +80°C	TD* dual carrier-frequency pickup and amplifier	pin 1+UB 8 up to 30 VDC pin 2out 1 push pull or open collector (fx1 or fx2) pin 30 V/ground pin 4out 2 push pull or open collector (fx1 or reverse flow) pin 5Com, 0V of open collector outputs
Local display and analogue output 4 to 20 mA ambient temp.: -40°C...+50°C fluid temp.: up to +120/+150°C	VTM local display unit	pin 1UB +8 (Ex: ü12) up to 30 VDC pin 2frequency output, three-wire pin 30 V/ground pin 4-Iout pin 5+Iout pin 6shield
Analogue output 4 to 20 mA ambient temp.: -40°C...+50°C fluid temp.: up to +120/+150°C	IWA local converter	pin 1n.c. pin 2frequency output pin 30 V/ground pin 4-Iout pin 5+Iout
high temperatures fluid temp.: up to +180°C	IF*HT inductive coil: VIEG inductive amplifier: for IF*HT	terminals A,Csignal terminal 1UB +7 up to 29 VDC terminal 20 V/ground terminal 3NPN/PNP output active/passive, 2-wire terminal 4screen terminal 5IF*HT coil A terminal 6IF*HT coil C
electro static paint spraying systems with 10 kV and more resistant to electromagnetic interference FOP: -20°C...+50 °C ambienttemp. OPTV: -20°C...+60°C	FOP fibre optic amplifier: OPTV receiver:lightwave pulse outputto be connected with OPTV receiver terminal 1signal output terminal 20 V/ground terminal 3n.c. terminal 4UB +7...30 V/DC

Datasheets with detailed descriptions are available for each pickup.

Ex Protection ATEX 100a

KEM electronics are available in Ex-protected design, ATEX 100a  II 2 G EEx ia IIC T6/T4, and with the intrinsically safe power supplies type EWS. Gear flow meters can be operated within Ex zone 1.

