



Summary

The Foxboro Eckardt 244LD *LevelStar* is for measurement of level, interface or density of liquids, with high accuracy, even under difficult conditions such as high pressure, high temperature and corrosive liquids, even in explosive atmospheres.

Business Value

The extensive product line gives you solutions for almost every application.

Ruggedised design and high reliability, easy configuration via digital communication and local LCD, long design life and freedom from maintenance reduces the effective costs running your plant and increases its profitability.

244LD *LevelStar*

High performance level transmitter

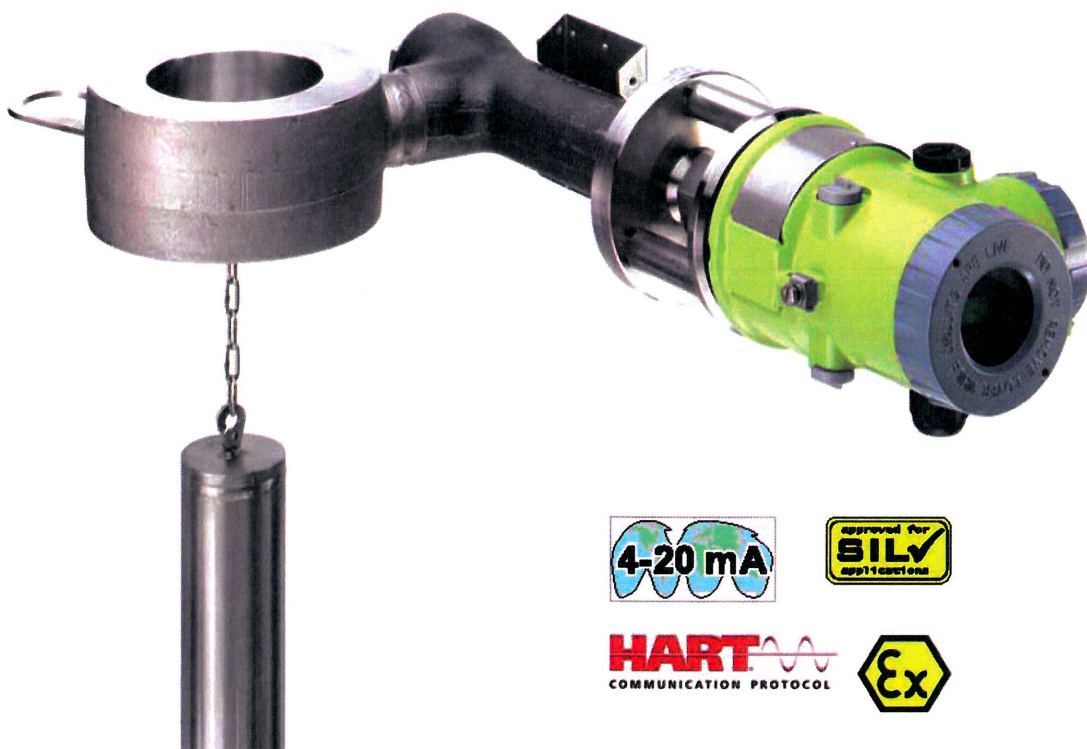

Best in class.

The 244LD *LevelStar* is designed to measure continuously level, interface or density for process and tank control. Its outstanding technical data makes it to one of the best Level Transmitters in the market. The latest FDT / DTM technology is used to offer online recalibration and diagnostic. The transmitter theory is based on Archimedes buoyancy principle. It is very rugged, has a long life cycle and requires no maintenance. A wide range of materials allows the optimal adaption to the process. The 244LD *LevelStar* is extremely reliable and very precise even at extreme process temperature and pressure.

The 244LD *LevelStar* joins the experience of Foxboro Eckardt with most advanced FDT / DTM technology and is the premium product in the Foxboro Eckardt level transmitter portfolio.

INTRA-AUTOMATION **IA**

MESS- UND REGELSTRUMENTE / MEASUREMENT AND CONTROL

Intra-Automation GmbH

Otto-Hahn-Str. 20 • 41515 Grevenbroich • GERMANY

Phone: +49- (0) 21 81 – 75 66 5-0

Fax: +49- (0) 21 81 – 6 44 92

<http://www.intra-automation.com>

Mailto: info@intra-automation.de

FOXBORO
ECKARDT

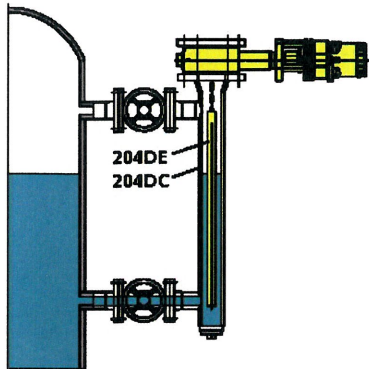

Mounted e.g. at side of vessel, with displacer chamber 204DC and displacer 204DE

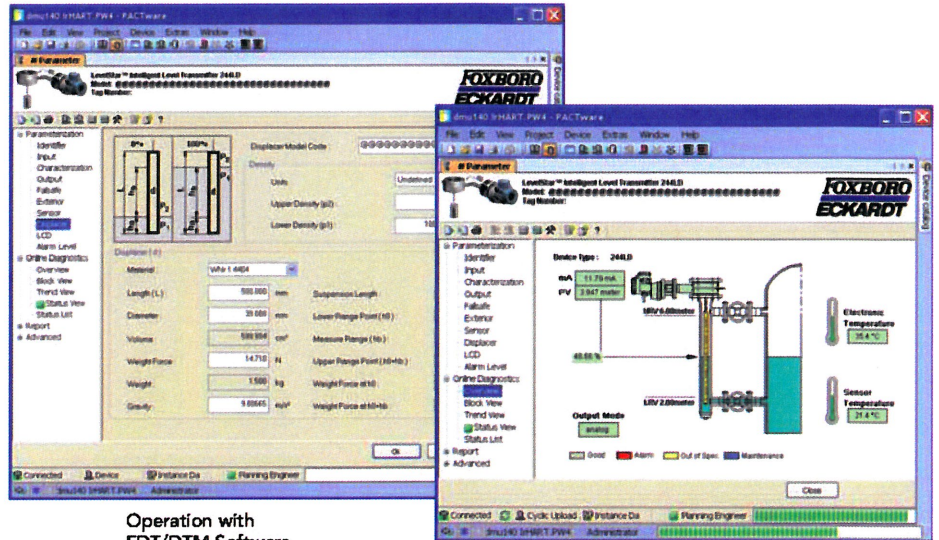

Operation with FDT/DTM Software

In Process

- Process temperature
-196 to +500 °C (-320 to +932 °F)
- Process pressure
vacuum to 550 bar /
ANSI Class 2500
- Measuring range
0 to 50 mm up to 0 to 10 m /
0 to 2 inch up to 0 to 30 feet
- Material (process wetted)
Steel 1.0460,
Stainless Steel 1.4404 or
Hastelloy C
- Accuracy $\pm 0.2\%$
- Sensor with no moving parts
- Reliable interface measurement -
also at diffuse interface
- Rel. Humidity up to 100 %,
condensation permitted
- Electrical Classification
Explosion Proof and Intrinsically
Safe acc. to ATEX and FM
- Optional Heating Jacket

Electronic

- Output Signal linear or
customized
- Communication
HART: Analog 4 to 20 mA
- Power Supply 12 to 42 V DC
- Protection of housing IP 66
- Temperature -40 to +85°C

Operation

- On the Instrument with
push buttons and LCD display
for configuration
- Digital with HART Hand Terminal
or FDT/DTM Software for
calibration and configuration
- LCD Display for Measured
values, Status and configuration

Influence in the Process

Temperature	▶ very little influence
Pressure	▶ very little influence
Steam, Fog	▶ no influence
Dielectric constant	▶ no influence
Foam	▶ no influence
Vibrations	▶ minimised due to Smart Smoothing + Damping
Motion of Fluid	▶ very little influence (if necessary use protecting tube or displacer chamber)
Diffuse Interface	▶ no influence
Displacer stroke	▶ Zero (no position alteration at liquid level change)
Corrosive Fluids	▶ no influence (instruments are delivered in resistant materials)
Vessel material	▶ no influence
Deposits on vessel	▶ no influence
Deposits on displacer	▶ very little influence

invenSYS

Invensys Operations Management • 5601 Granite Parkway III, #1000, Plano, TX 75024 • Tel: (469) 365-6400 • Fax: (469) 365-6401 • www.invensys.com

Invensys, the Invensys logo, ArchemA, Avantis, Eurotherm, Foxboro, IMServ, InFusion, SimSci-Esscor, Triconex, and Wonderware are trademarks of Invensys plc, its subsidiaries or affiliates. All other brands and product names may be the trademarks or service marks of their representative owners.

© 2010 Invensys Systems, Inc. All rights reserved. No part of the material protected by this copyright may be reproduced or utilized in any form or by any means, electronic or mechanical, including photocopying, recording, broadcasting, or by any information storage and retrieval system, without permission in writing from Invensys Systems, Inc.