

SMART PRESSURE TRANSMITTER

Type: APC-2000ALW



Technical Information

04/2012



Accessories

Intra-Automation
Technical Information
04/2012

Technical details subject to be changed without notice.

For comments regarding this brochure, please contact:
info@intra-automation.de

SMART PRESSURE TRANSMITTER

Type: APC-2000ALW

Features

- ◆ Digital PROFIBUS PA signal
- ◆ Programmable range, zero shift, characteristic and damping ratio with local panel keys
- ◆ 4...20 mA, 0...20 mA or 0...5 mA output signal + HART protocol
- ◆ ATEX Intrinsic safety
- ◆ ATEX Explosion-proof
- ◆ PED conformity (97/23/EC)
- ◆ Accuracy 0,075 %
- ◆ Rangeability 100:1

Application

Applicable to measure the pressure of dusty gases and viscous or solidifying liquids at the ranges from -100...100 mbar to 0...70 bar.

The transmitters with flush diagram are applied in food industry and pharmaceutical industry in aseptic systems. Using of our fitting sockets with a seal upstream the connection shank thread is recommended.

Smart pressure transmitters are applicable to measure pressure, under-pressure and absolute pressure of gases, vapours and liquids. The active sensing element is a piezo-resistant silicone sensor separated from the medium by a diaphragm and by specially selected type of manometric liquid. The casing is made of aluminium alloy cast, degree of protection IP66. The design of the casing enables the use of a local display, rotation of the display by 90°, rotation of the casing by 0-355°, relative to the sensor, and a choice of cable directions.

SMART PRESSURE TRANSMITTER

Type: APC-2000ALW

List of contents:

Chapt..	Title	Page
1.	Design and Dimensions	4
2.	Process Connections	5
3.	Versions	6
4.	Communication and Configuration	6
5.	Installation	6
6.	Electrical Diagrams for Transmitter with HART-Protocol	7
7.	Measuring Ranges	8
8.	Technical Data	8
9.	Special Versions, Certificates	9
10.	APC-2000AL/Profibus PA	9
11.	Ordering Information	11

1. Design and Dimensions

a) Front view:

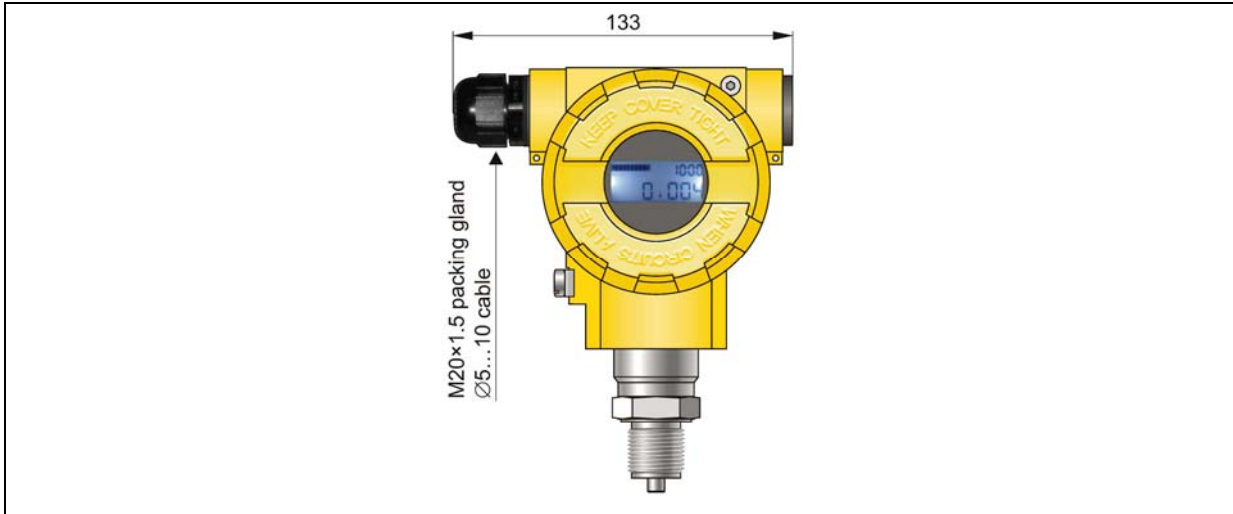

b) Side view:

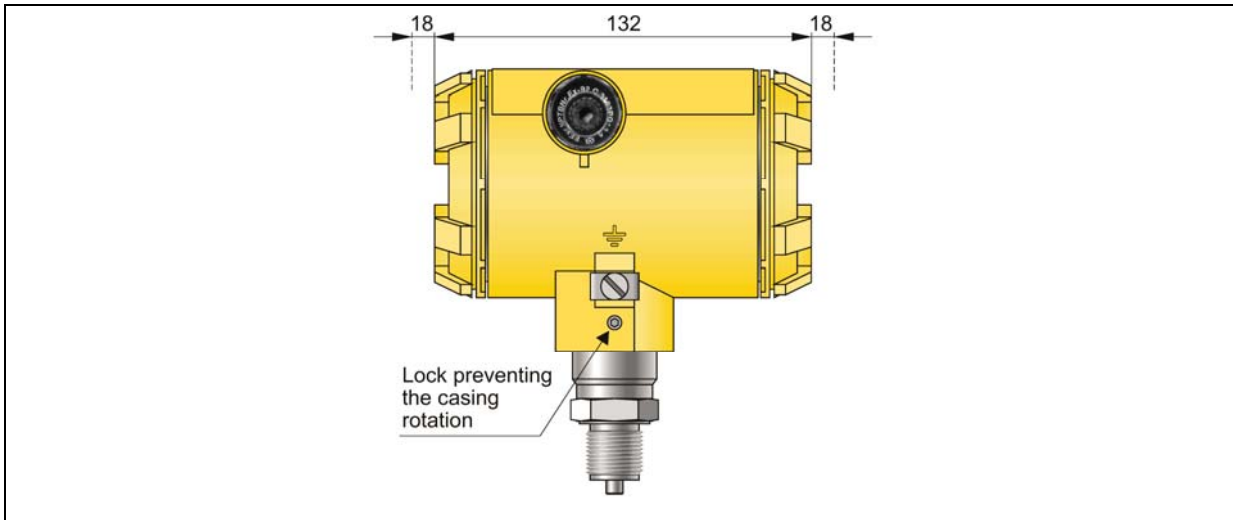

c) Rear view:

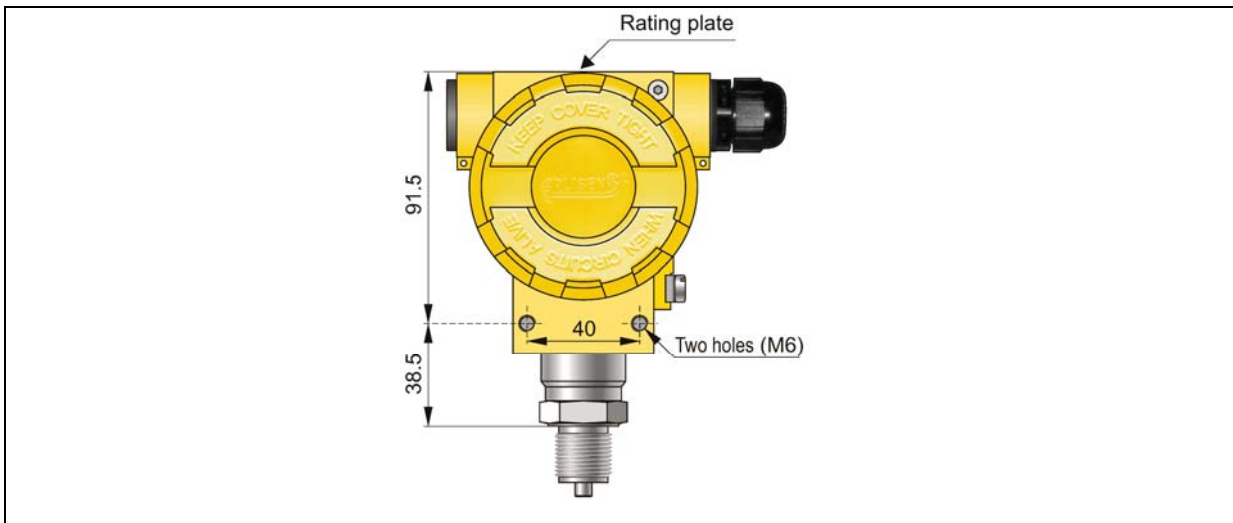

2. Process connections

a) G1/2 type; M type:

G1/2", \varnothing 4 hole (G1/2 type)
 M20x1.5, \varnothing 4 hole (M type)
 Wetted parts material: 316L

Application:
 Pressure measurement of uncontaminated
 gases, vapours and liquids.

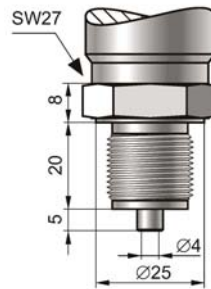

b) 1/2"NPT type:

1/2"NPT, internal thread G1/4"
 Wetted parts material: 316L

Min range: 0,25 bar
 Max range: 300 bar

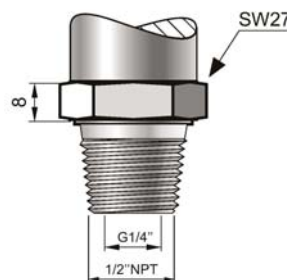

c) GP type, P type:

G1/2", \varnothing 12 hole (GP type)
 M20x1.5, \varnothing 12 hole (P type)
 Wetted parts material:
 - 316L (standard)
 - Hastelloy C-276

Application:
 Pressure measurement of viscous and
 contaminated media.
 Max. meas. range: 0...300 bar

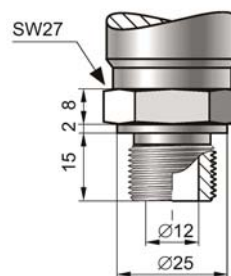

d) CG1 type:

G1" with flush diaphragm
 Wetted parts material:
 - 316L (standard)
 - Hastelloy C-276

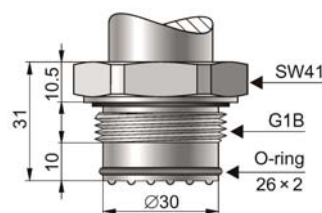

e) CM30x2 type:

M30x2 with flush diaphragm
 Wetted parts material:
 - 316L (standard)
 - Hastelloy C-276

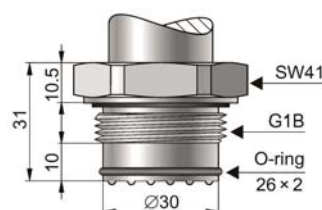

3. Versions

a) Version APC-2000ALW:



- ◆ 4...20 mA output signal + HART protocol or digital Profibus PA signal
- ◆ Possibility of adjusting both zero point and start and end of the measuring range, characteristic etc. by means of the display panel keys
- ◆ Configurable display 5 digits with illumination (working temperature range: -40...+85°C)
- ◆ ATEX intrinsic safety Ex II 1/2G Ex ia IIC T5
- ◆ ATEX explosion proof Ex II 1/2G Ex d ia IIC T5

b) Version APC-2000ALE:



- ◆ 0...20 mA; 0...5 mA; 4...20 mA output signal + HART protocol
- ◆ Possibility of adjusting both zero point and start and end of the measuring range according to set pressure by means of the display panel keys
- ◆ Configurable display (LCD) 3 ½ digits (working temperature range: -40...+85°C)
- ◆ No EEx or Profibus PA

4. Communication and Configuration

The communication standard for data interchange with the transmitter is the HART-protocol.

Communication with the transmitter is carried out with:

- a KAP-03 communicator,
- some other HART communicators (on request),
- a PC using a RS-HART converter and Raport-01 configuration software. Along with the Raport-01, the SECTIONAL LINEARIZATION software is supplied. The software enables leading of the 21-point, non-linear user's characteristic into the transmitter.

The data interchange with the transmitter enables the user to:

- identify the transmitter;
- configure output parameters.
 - measurement units and the values of the start points and end points at the measurement range;
 - damping time constant;
 - conversion characteristics (inversion, user's non-linear characteristic)
- read the currently measured pressure value of the output current and the percentage control level;
- force and output current with a set value;
- calibrate the transmitter in relation to a model pressure.

5. Installation

The transmitter is not heavy, so it can be installed directly on the installation. A universal mounting bracket is provided to transmitter fitting on 2" pipe. When the pressure of steam or other hot media is measured, a siphon or impulse line should be used. The needle valve placed upstream the transmitter simplifies installation process and enables the zero point adjustment or the transmitter replacement. When special process connections are required for the measurement of levels and pressures (e.g. at food and chemical industries), the transmitter is provided with a diaphragm seal. Installing accessories an a full scope of diaphragm seals are described in detail in the further part of the catalogue. The transmitter's electrical connection should be performed with twisted cable. The place for the communicator should be assigned before the communicator installation.

6. Electrical diagrams for transmitters with HART-protocol

a) Version: ABC-2000ALW:

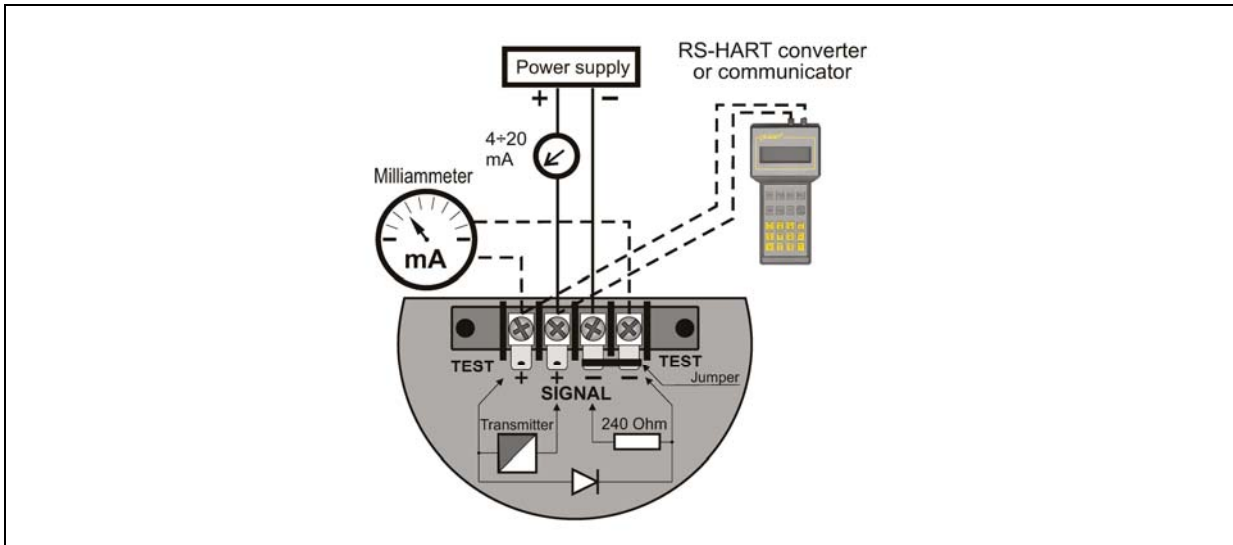

b) Version APC-2000ALE with 4...20 mA output signal:

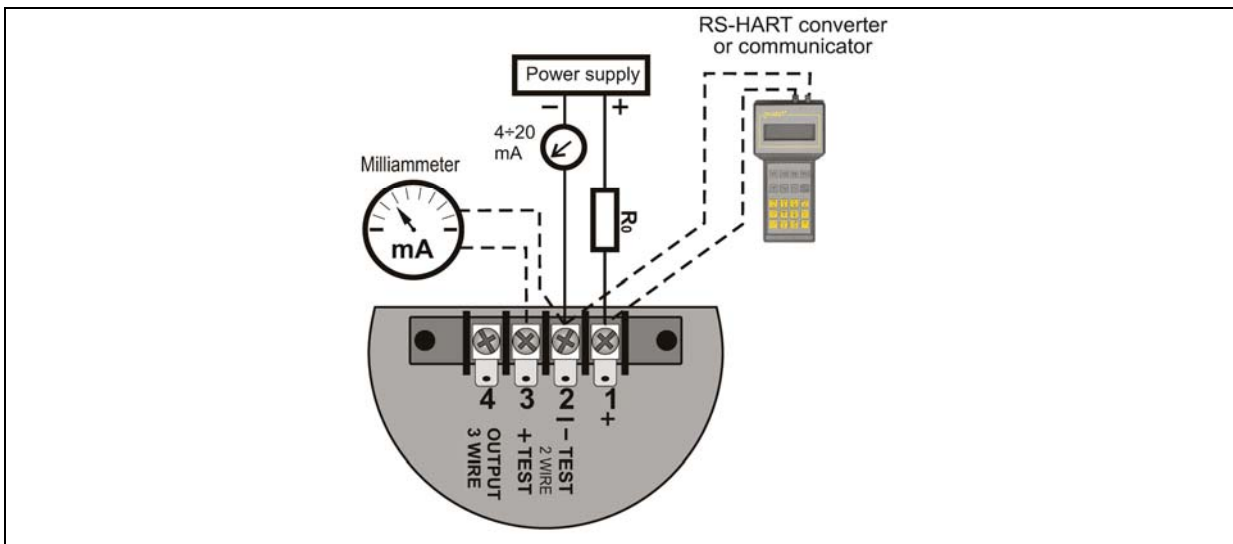

b) Version APC-2000ALE with 0...5 or 0...20 mA output signal:

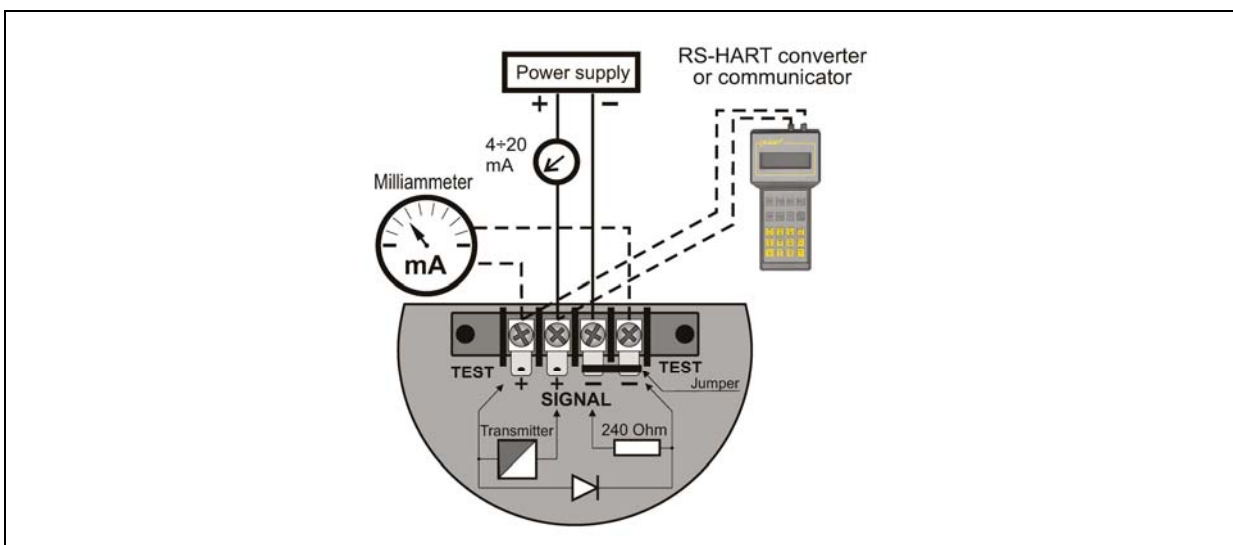

7. Measuring ranges

No.	Nominal measuring range [FSO]		Minimum set range		Rangeability	Overpressure limit (without hysteresis)	
1	0...1000 bar	(0...100 MPa)	10 bar	(1 MPa)	100:1	1200 bar	(120 MPa)
2	0...300 bar	(0...30 MPa)	3 bar	(300 kPa)	100:1	450 bar	(45 MPa)
3	0...160 bar	(0...16 MPa)	1,6 bar	(160 kPa)	100:1	450 bar	(45 MPa)
4	0...70 bar	(0...7 MPa)	0,7 bar	(70 kPa)	100:1	140 bar	(14 MPa)
5	0...25 bar	(0...2,5 MPa)	0,25 bar	(25 kPa)	100:1	50 bar	(5 MPa)
6	0...7 bar	(0...0,7 MPa)	0,07 bar	(7 kPa)	100:1	14 bar	(1,4 MPa)
7	-1...6 bar	(-100...600 kPa)	300 mbar	(30 kPa)	23:1	14 bar	(1,4 MPa)
8	-1...1,5 bar	(-100...150 kPa)	120 mbar	(12 kPa)	20:1	4 bar	(400 kPa)
9	0...2 bar	(0...200 kPa)	100 mbar	(10 kPa)	20:1	4 bar	(400 kPa)
10	0...1 bar	(0...100 kPa)	50 mbar	(5 kPa)	20:1	2 bar	(200 kPa)
11	-0,5...0,5 bar	(-50...50 kPa)	50 mbar	(5 kPa)	20:1	2 bar	(200 kPa)
12	0...0,25 bar	(0...25 kPa)	25 mbar	(2,5 kPa)	10:1	1 bar	(100 kPa)
13	-100...100 mbar	(-10...10 kPa)	20 mbar	(2 kPa)	10:1	1 bar	(100 kPa)
14	-15...70 mbar	(-1,5...7 kPa)	5 mbar	(0,5 kPa)	17:1	0,5 bar	(50 kPa)
15	0...1,1 bar abs	(0...110 kPa abs)	50 mbar abs	(5 kPa abs)	22:1	2 bar	(200 kPa)
16	0...7 bar abs	(0...700 kPa abs)	0,07 bar abs	(7 kPa abs)	100:1	14 bar	(1,4 MPa)
17	0...25 bar abs	(0...2,5 MPa abs)	0,25 bar abs	(25 kPa abs)	100:1	50 bar	(5 MPa)
18	0...70 bar abs	(0...7 MPa abs)	0,7 bar abs	(70 kPa abs)	100:1	140 bar	(14 MPa)

8. Technical data

a) Metrological parameters:

- Accuracy : $\leq \pm 0,075$ % of the calibrated range
- Long-term stability : \leq accuracy for 3 years
(for the nominal meas. range)
- Thermal error : $< \pm 0,08$ % (FSO) / 10 °C
(0,1 % for ranges 10,11)
max. $\pm 0,25$ % (FSO) in the whole compensation range
(0,4 % for ranges 10,11)
- Thermal compensation range : -25...+80 °C
-40...+80 °C special version
- Add. electronic damping : 0...60 s
- Error due to supply voltage changes : 0,002 % (FSO) / V

b) Electrical parameters:

- Power supply : 12...45 V DC (EEx 13,5...28 V)
- Additional voltage drop when display illumination is switched on : 3 V
- Output signal : 4...20 mA, two wire transmission
- APC-2000 ALE : 0...20 or 0...5, 4...20 [mA]
- Load resistance : $R[\Omega] \leq \frac{U_{sup}[V] - 12V^*}{0,02A} \times 0,85$

*-15 V when display illumination is switched on.

- Resistance required for communication : 250...1100 Ω
- Accuracy depending on the set range :

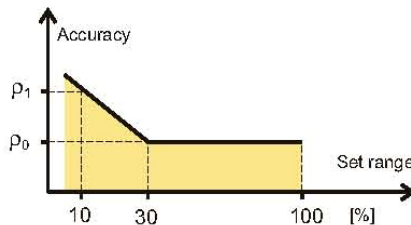

ρ_0 – error for nominal measuring range 0...100 % FSO

ρ_1 – error for range 0...10 % FSO

$\rho_1 = 2 \times \rho_0$

Numerical error values are given in the technical data under metrological parameters.

Enclosed to APC-2000AL/Profibus PA is GSD file comprising the description of the transmitter basic properties such as transmission rate, type and format of input data, list of additional functions. GSD file is necessary for the software serving as a device for network configuration and makes the correct connection to Profibus network possible. The universal file GSD, designed for standard pressure transmitters (acc. profile of rev. 3 Profibus-standard) may also be applicable to APC-2000AL/Profibus PA.

The pressure transmitter APC-2000AL/Profibus PA does not have a hardware address switch. This address may be adjusted by accessible configuration software.

f) Measurements in explosion hazardous atmospheres:

ATEX intrinsically safe transmitters (Ex II 1/2G EExia IIB/T5) are available.

g) Technical data:

For metrological parameters, materials of process connection, diaphragms and casing, and operating conditions, please see page 8+9.

h) Electrical parameters:

Power supply (from DP/PA coupler)	:	10,5...28 V DC 12,5...28 V DC – when display illumination switched on. Power supply from intrinsically safe coupler according to FISCO requirements. $V_i = 17,5$ V DC $I_i = 0,38$ A for IIB $I_i = 0,36$ A for IIC
Current consumption	:	14 mA

i) Output parameters:

Output signal	:	Digital communication signal Profibus-PA (acc. to EN 50170)
PA function	:	Slave
Physical layer	:	IEC 61158-2
Transmission rate	:	31,25 kBit/s

j) Electrical diagram:

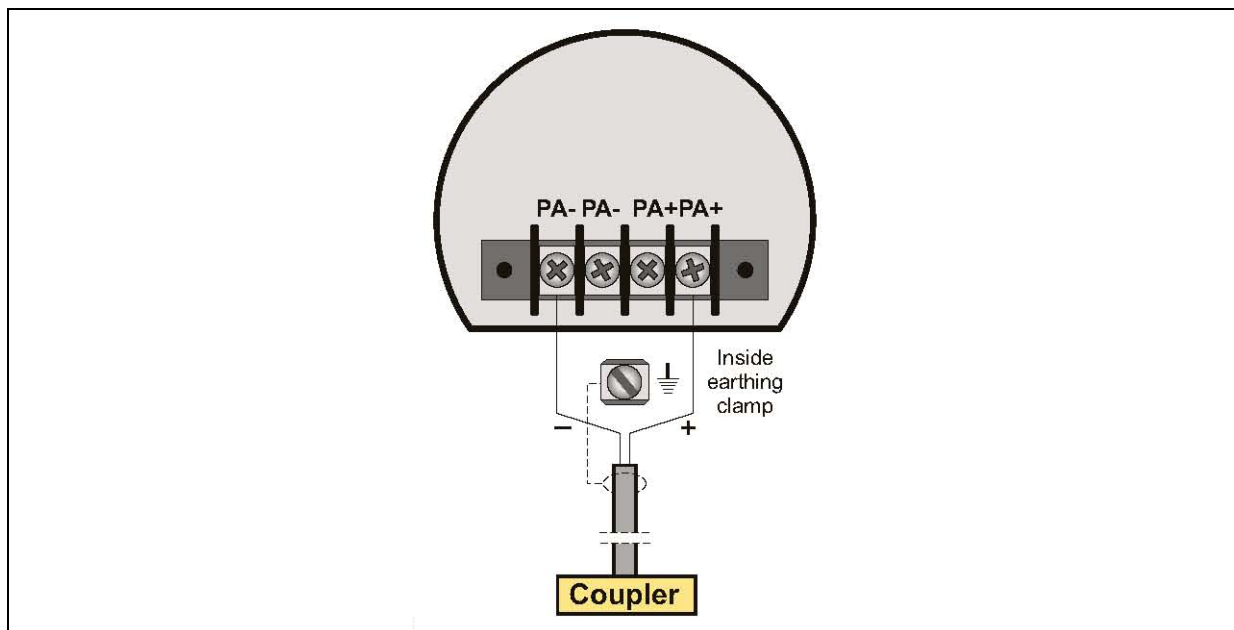

11. Ordering information

Description	Code
Smart pressure transmitter	APC-2000
Housing, input signal	
Aluminium housing, IP66, with display, output 4...20 mA + HART ←	ALW
Aluminium housing, IP66, with display, output 4...20 mA + HART, 0...20 mA + HART, 0...5 mA + HART	ALE
Aluminium housing, IP66, without display, output Profibus PA	AL/Profibus PA
Aluminium housing, IP66, with display, output Profibus PA	AL/Profibus PA/W
Versions / Certificates (more than one option is available)	
Ex II 1/2G Exia IIC T5 (not available for ALE) for Profibus PA version: Ex II 1/2G EExia IIB T5	/EExia
Ex II 1/2G EEx d ia IIC T5, for pressure >250 mbar (not available for ALE, AL/Profibus PA, AL/Profibus PA/W), packing gland available on request	/EExd
European Pressure Equipment Directive 97/23/EC, category IV	/PED
For oxygen service (sensor filled with Fluorolube liquid) only M and G1/2 connections	/Tlen
Extended thermal compensation range -60...+50 °C	/-60...+50C
Extended thermal compensation range -40...+80 °C	/-40...+80C
Nominal measuring range (Non-standard ranges available on request)	
Range	Min. set range
0...1000 bar (0...100 MPa)	10 bar (1 MPa)
0...300 bar (0...30 MPa)	3 bar (300 kPa)
0...160 bar (0...16 MPa)	1,6 bar (160 kPa)
0...70 bar (0...7 MPa)	0,7 bar (70 kPa)
0...25 bar (0...2,5 MPa)	0,25 bar (25 kPa)
0...7 bar (0...0,7 MPa)	0,07 bar (7 kPa)
-1...6 bar (-100...600 kPa)	300 mbar (30 kPa)
-1...1,5 bar (-100...150 kPa)	120 mbar (12 kPa)
0...2 bar (0...200 kPa)	100 mbar (10 kPa)
0...1 bar (0...100 kPa)	50 mbar (5 kPa)
-0,5...0,5 bar (-50...50 kPa)	50 mbar (5 kPa)
0...0,25 bar (0...25 kPa)	25 mbar (2,5 kPa)
-100...100 mbar (-10...10 kPa)	20 mbar (2 kPa)
-15...70 mbar (-1,5...7 kPa)	5 mbar (0,5 kPa)
0...1,1 bar abs (0...110 kPa abs)	50 mbar abs (5 kPa abs)
0...7 bar abs (0...700 kPa abs)	0,07 bar abs (7 kPa abs)
0...25 bar abs (0...2,5 MPa abs)	0,25 bar abs (25 kPa abs)
0...70 bar abs (0...7 MPA abs)	0,7 bar abs (70 kPa abs)
Measuring Range	
Start and end of calibrated range in relation to 4 mA and 20 mA output.	/...-(required units)
Process connection	
Thread M20x1,5 (male) with Ø 4 mm hole, wetted parts 316L ←	/M
Thread G1/2" (male) with Ø 4 mm hole, wetted parts 316L	/G1/2
Thread M20x1,5 (male) with Ø 12 mm hole, wetted parts 316L	/P
Thread M20x1,5 (male) with Ø 12 mm hole, wetted parts Hastelloy C 276	/P (Hastelloy)
Thread G1/2" male with Ø 12 mm hole, wetted parts 316L	/GP
Thread G1/2" male with Ø 12 mm hole, wetted parts Hastelloy C 276	/GP (Hastelloy)
Thread M30x2 with flush diaphragm, wetted parts 316L	/CM30x2
Thread M30x2 with flush diaphragm, wetted parts Hastelloy C276	/CM30x2 (Hastelloy)
Thread G1" with flush diaphragm, wetted parts 316L	/CG1
Thread G1/2" with flush diaphragm, wetted parts 316L	/CG1/2
Thread 1/2"NPT male, wetted parts 316L	/1/2NPT M
Thread M20x1,5 with adapter to 1/2"NPT female, wetted parts 316L	/1/2NPT F
Diaphragm seal	/code of diaphr. seal
Electrical connection	
Packing gland M20x1,5 (standard) ←	(without coding)
Tread 1/2"NPT female	/US
Accessories	
Mounting bracket type AL. for 2" pipe, material zinc steel ←	/AL
Other specifications	
Description of required parameters (e.g. non-standard process connection G3/4" or M22x1,5)	/.....

The most typical specification is marked by an ← arrow.

Besides the products covered by this brochure, Intra-Automation GmbH also manufactures other high-quality and high precision instruments for industrial measurement tasks. For more information, please contact us (contact details on the backside of this brochure).

Flow measurement



Itabar®-Flow Sensor



IntraSonic IS210 Ultrasonic Flow Meter

Level measurement



ITA-mag. Level Gauge



MAGLINK Level Indicator

Other Measurement Tasks:



DigiFlow Flow and Level Computers



IntraCon Digital Controllers



IntraDigit Digital Indicators / Meters



INTRA-AUTOMATION

MESS- UND REGELINSTRUMENTE / MEASUREMENT AND CONTROL



TÜVRheinland®
CERT
ISO 9001

International Headquarters:

Intra-Automation GmbH
Otto-Hahn-Str. 20
41515 Grevenbroich
GERMANY

☎ +49 – (0) 21 81 / 7 56 65-0

☎ +49 – (0) 21 81 / 6 44 92

✉ info@intra-automation.de

🌐 www.intra-automation.com

Sales Office for the BENELUX:

B.V. Intra-Automation HTP
PO Box 10
4730 AA Oudenbosch
THE NETHERLANDS

☎ +31 – (0)165 – 32 22 01

☎ +31 – (0)165 – 32 29 70

✉ info@intra-automation.nl