

2600T Series Pressure Transmitters

Model 267CS Multivariable
for mass flow
selectable maximum working pressure
up to 41MPa, 5945psi

- **Base accuracy : $\pm 0.075\%$**
- **Span limits**
 - 0.05 to 2000kPa, 0.2inH₂O to 290psi differential pressure
 - 0.6 to 41MPa, 87 to 5945psia absolute pressure
- **One transmitter replaces three separate transmitter, saving initial purchase cost**
- **Reduced process penetrations save money and reduce chances of leak**
- **Fewer transmitters, less wiring, and fewer shut off valves reduce installation costs**
- **Greater reliability due to fewer devices and less wiring**
- **Flexible configuration facilities**
 - provided by PC configuration platform
- **Multiple protocol availability**
 - provides integration with HART®, PROFIBUS PA, FOUNDATION Fieldbus and Modbus platforms offering interchangeability and transmitter upgrade capabilities
- **Full compliance with PED category III**



**2600T Series
Engineered solutions
for all applications**

Functional Specifications

The 267CS allows due to its multisensor technology the measurement of three separate process variables simultaneously and provides the ability of dynamic calculation of fully compensated mass or volume flowrate for gases, steam and liquids.

It measures differential pressure and absolute pressure from a single sensor and process temperature from a standard 100-ohm Resistance Temperature Detector (RTD).

The flow calculation of 267CS includes compensation of pressure and/or temperature as well as more complex variables such as discharge coefficient, thermal expansion, Reynolds number and compressibility factor.

The 267CS includes flow equations for superheated steam, saturated steam, gases and liquids so that one model is all you need in your plant. The enhanced compensation approach of 267CS provides a much better accuracy than the "old approach" where three different transmitters, differential pressure, absolute pressure and temperature, report their values to a DCS, PLC or flow computer and where the calculation considers changes in temperature and pressure according to:

$$Q_m \approx \sqrt{dp \cdot \frac{\rho}{T}}$$

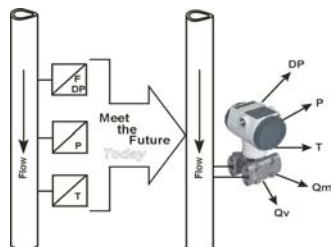

The dynamic mass flow compensation of 267CS is based on AGA 3 and EN ISO 5167:

$$Q_m \approx C \cdot E_v \cdot Y_1 \cdot d^2 \sqrt{dp \cdot \rho}$$

- Q_m = mass flowrate
- C = discharge coefficient
- E_v = velocity of approach factor
- Y₁ = gas expansion factor
- d = bore diameter
- dp = differential pressure
- ρ = fluid density

Discharge coefficient

It is defined as the true flowrate divided by the theoretical flowrate and corrects the theoretical equation for the influence of velocity profile (Reynolds number), the assumption of no energy loss between taps, and pressure tap location. It is dependent on the primary flow element, the β ratio and the Reynolds number. Reynolds number is in turn dependent on the viscosity, density and velocity of the fluid as well as the pipe diameter per the following equation:

$$Re = \frac{v \cdot D \cdot \rho}{\nu}$$

v = velocity

D = inside pipe diameter

ρ = fluid density

ν = fluid viscosity

Dynamical compensation for discharge coefficient provides high accuracy for orifice, Venturi and nozzles.

Gas expansion factor

It corrects for density differences between pressure taps due to expansion of compressible fluids. It does not apply for liquids which are essentially non-compressible.

The gas expansion factor is dependent on the Beta ratio, the Isentropic exponent, the differential pressure and the static pressure of the fluid per the following equation.

For orifices:

$$Y_1 = 1 - (0.41 + 0.35\beta^4) \frac{dp}{p \cdot \kappa}$$

For nozzles:

$$Y_1 = \left[\left(\frac{\kappa \left(\frac{dp}{p} \right)^{\frac{2}{\kappa}}}{\kappa - 1} \right) \left(\frac{1 - \beta^4}{1 - \beta^4 \left(\frac{dp}{p} \right)^{\frac{2}{\kappa}}} \right) \left(\frac{1 - \left(\frac{dp}{p} \right)^{\frac{\kappa-1}{\kappa}}}{1 - \left(\frac{dp}{p} \right)} \right) \right]^{\frac{1}{2}}$$

β = beta ratio

dp = differential pressure

p = static pressure

κ = Isentropic exponent

Velocity of approach factor

Is dependent on the Beta ratio as defined by the following equation:

$$E_v = \frac{1}{\sqrt{1 - \beta^4}}$$

In turn, Beta ratio is dependent on bore diameter and pipe diameter which are functions on temperature. The material of process pipe and primary flow element expands or contracts with changes in temperature of the fluid being measured. The thermal expansion coefficients are depended on the the material of pipe and flow element and are used for calculating the change in diameters.

This ensures high flowrate accuracy at low and high temperature applications.

Density of fluids

It directly effects the flowrate calculation. The 267CS compensates for density of fluids for changes in temperature and/or pressure as follows:

- Gases as a function of P and T per the gas law equations.
- Heated steam as function of P and T based on steam tables
- Saturated steam as function of P based on steam tables
- Liquids as a function of T

Mass flow calculation with 267CS will be configured for the following primary elements:

- Orifice Corner Taps, ISO
- Orifice Flange Taps, ISO
- Orifice D- and D/2-Taps, ISO
- Orifice Corner Taps, ASME
- Orifice Flange Taps, ASME
- Orifice D- and D/2-Taps, ASME
- Orifice Flange Taps, AGA3
- Orifice 2,5D- and 8D-Taps
- Small bore orifice, flange taps
- Small bore orifice, corner taps
- Nozzle ISA 1932
- Nozzle, Long Radius Wall Tap, ISO
- Nozzle, Long Radius Wall Tap, ASME
- Venturi, Rough Cast Inlet, ISO
- Venturi, Machined Inlet, ISO
- Venturi, Welded Inlet, ISO
- Venturi, Rough Cast Inlet, ASME
- Venturi, Machined Inlet, ASME
- Venturi, Welded Inlet, ASME
- Venturi, Nozzle, ISO
- Area Averaging Meter
- Pitot tube, ISO 3966
- V-Cone
- Wedge Element
- Integral Orifice Assembly
- Density Correction (unknown Primary Element)

Configuration of full functionality of 267CS including all data necessary or mass flow compensation will be done via PC based tool Smart Vision.

Functional Specifications

Range and span limits

- differential pressure sensors

Sensor Code	Upper Range Limit (URL)	Lower Range Limit (LRL)	Minimum Span
A	1kPa 10mbar 4inH ₂ O	0	0.05kPa 0.5mbar 0.2inH ₂ O
C	6kPa 60mbar 24inH ₂ O	0	0.2kPa 2mbar 0.8inH ₂ O
F	40kPa 400mbar 160inH ₂ O	0	0.4kPa 4mbar 1.6inH ₂ O
L	250kPa 2500mbar 1000inH ₂ O	0	2.5kPa 25mbar 10inH ₂ O
N	2000kPa 20bar 290psi	0	20kPa 0.2bar 2.9psi

- absolute pressure sensors

Sensor Code	Upper Range Limit (URL)	Lower Range Limit (LRL)	Minimum Span
1	600kPa 6bar 87psi	0abs	6kPa 0.06bar 0.87psi
2	2000kPa 20bar 290psi	0abs	20kPa 0.2bar 2.9psi
3	10000kPa 100bar 1450psi	0abs	100kPa 1bar 14.5psi
4	41000kPa 410bar 5945psi	0abs	410kPa 4.1bar 59.5psi

Span limits

Maximum span = URL

IT IS RECOMMENDED TO SELECT THE TRANSMITTER SENSOR CODE PROVIDING THE TURNDOWN VALUE AS LOWEST AS POSSIBLE TO OPTIMIZE PERFORMANCE CHARACTERISTICS.

Zero suppression and elevation

No suppression or elevation but zero based range as long as

- calibrated span \geq minimum span

Process temperature range

-50°C to +650°C (-58°F to 1200°F) by external four-wire RTD

Damping

Adjustable time constant : 0 to 60s.

This is in addition to sensor response time

Turn on time

Operation within specification in less than 2.5s with minimum damping.

Insulation resistance

> 100M Ω at 1000VDC (terminals to earth)

Operative limits

Temperature limits °C (°F) :

Ambient (is the operating temperature)

Silicone oil filling: -40°C and +85°C (-40°F and +185°F)

Inert filling: -20°C and +85°C (-4°F and +185°F)

Lower ambient limit for Viton and PTFE gaskets: -20°C (-4°F)

Note : For Hazardous Atmosphere applications see the temperature range specified on the certificate/approval relevant to the aimed type of protection

Process

Lower limit

- refer to lower ambient limits

Upper limit

- Silicone oil: 121°C (250°F)

for working pressure above 10kPa abs, 100mbar abs, 1.45psia(1)

- Inert fluid: 121°C (250°F) (2)

for working pressure above atmospheric pressure

(1) 85°C (185°F) for application below 10kPa abs, 100mbar abs, 1.45psia down to 3.5 kPa abs, 35mbar abs, 0.5psia

(2) 85°C (185°F) for application below atmospheric pressure down to 40kPa abs, 400mbar abs, 5.8psia.

Storage

Lower limit: -50°C (-58°F); -40°C (-40°F) for LCD indicators

Upper limit: +85°C (+185°F)

Pressure limits

Overpressure limits (without damage to the transmitter)

Lower limit

- 0.5kPa abs, 5mbar abs, 0.07psia for silicone oil

- 40kPa abs, 400mbar abs, 5.8psia for inert fluid

Upper limit

- 0.6MPa, 6bar, 87psi for differential pressure sensor code A

- 2MPa, 20bar, 290psi or 10MPa, 100bar, 1450psi or 41MPa, 410bar, 5945psi for differential pressure sensor codes C, F, L, N according to selected code variant.

Static pressure

Transmitters for differential pressure model 267CS operates within specifications between the following limits

Lower limit

- 3.5kPa abs, 35mbar abs, 0.5psia for silicone oil

- 40kPa abs, 400mbar abs, 5.8psia for inert fluid

Upper limit

- 0.6MPa, 6bar, 87psi for differential pressure sensor code A

- 2MPa, 20bar, 290psi or 10MPa, 100bar, 1450psi or 41MPa, 410bar, 5945psi for differential pressure sensor codes C, F, L, N according to selected code variant.

Proof pressure

The transmitter can be exposed without leaking to line pressure of up to 1.5 times the nominal pressure simultaneously on both sides.

Environmental limits

Electromagnetic compatibility (EMC)

Definition Class 3
 Radio suppression Limit class B (according to EN 550011)
 Fulfills NAMUR recommendation

Low voltage directive

Comply with 73/23/EEC

Pressure equipment directive (PED)

Instruments with maximum working pressure 41MPa, 410bar, 5945psi comply with 97/23/EEC Category III module H.

Humidity

Relative humidity: up to 100% annual average
 Condensing, icing: admissible

Vibration resistance

Accelerations up to 2g at frequency up to 1000Hz (according to IEC 60068–2–26)

Shock resistance (according to IEC 60068–2–27)

Acceleration: 50g
 Duration: 11ms

Wet and dust-laden atmospheres

The transmitter is dust and sand tight and protected against immersion effects as defined by IEC EN60529 (1989) to IP 67 (IP 68 on request) or by NEMA to 4X or by JIS to C0920.

– Transmitters of the type of protection "Intrinsically safe EEx ia" according to the directions 94 / 9 / EC (ATEX)
Transmitter with 4 to 20mA output signal and HART communication
 Marking (DIN EN 50 014): II 1/2 GD T50°C EEx ia IIC T6 or resp. II 1/2 GD T95°C EEx ia IIC T4

Supply and signal circuit type of protection Intrinsic Safety EEx ib IIB/IIC resp. EEx ia IIB/IIC
 for connection to supply units with maximum values:
 II 1/2 GD T50°C EEx ia resp. ib IIC T6 resp.
 II 1/2 GD T95°C EEx ia resp. ib IIC T4
 for Temperature class T4 resp. T95°C:

U_i = 30V
 I_i = 200mA
 P_i = 0.8W for T4 with T_a = (–40 to +85)°C / (–40 to +185)°F
 P_i = 1.0W for T4 with T_a = (–40 to +70)°C / (–40 to +158)°F

for Temperature class T6 resp. T50°C:
 P_i = 0.7W for T6 with T_a = (–40 to +40)°C / (–40 to +104)°F
 effective internal capacitance, C_i ≤ 10nF
 effective internal inductance, negligible.

Fieldbus transmitters (PROFIBUS PA / FOUNDATION Fieldbus)
 Marking (DIN EN 50 014): II 1/2 GD T50°C EEx ia IIC T6 or resp. II 1/2 GD T95°C EEx ia IIC T4

Supply and signal circuit type of protection Intrinsic Safety EEx ib IIB/IIC resp. EEx ia IIB/IIC
 for connection to FISCO supply units with rectangular or trapezoidal characteristics with maximum values:

II 1/2 G EEx ia respectively ib IIC T4/T6 U_i = 17.5V
 I_i = 360mA
 P_i = 2.52W
 II 1/2 G EEx ia respectively ib IIB T4/T6 U_i = 17.5V
 I_i = 380mA
 P_i = 5.32W

resp. for connection to supply unit or barrier with linear characteristics with maximum values:

II 1/2 G EEx ia respectively ib IIC T4/T6 U_i = 24V
 I_i = 250mA
 P_i = 1.2W

effective internal inductance L_i ≤ 10 μH,
 effective internal capacitance C_i ≈ 0
 Maximum permissible ambient temperatures depending on the temperature class:
 T4: –40°C to +85°C (–40°F to +185°F)
 T5, T6: –40°C to +40°C (–40°F to +104°F)

– Transmitters of the type of protection "flameproof enclosure EEx d" according to the directions 94 / 9 / EC (ATEX)
Transmitter with 4 to 20mA output signal and HART communication and Fieldbus transmitters (PROFIBUS PA / FOUNDATION Fieldbus)
 Marking (DIN EN 50 014): II 1/2 G EEx d IIC T6
 Ambient temperature range: –40°C to +75°C (–40°F to +167°F)

– Transmitters of category 3 for the application in "Zone 2"
Transmitter with 4 to 20mA output signal and HART communication
 according to the directions 94 / 9 / EC (ATEX)
 Marking (DIN EN 50 014): II 3 GD T50°C EEx nL IIC T6 or resp. II 3 GD T95°C EEx nL IIC T4

Operating conditions:
 Supply and signal circuit (terminals signal +/-): U ≤ 45V
 I ≤ 22.5mA

connector for external passive temperature sensor
 supply and signal circuit: U ≤ 10.5V
 I ≤ 1.5mA
 P ≥ 4mW

Ambient temperature range:
 Temperature class T4 T_a = –40°C to +85°C (–40°F to +185°F)
 Temperature class T5, T6 T_a = –40°C to +40°C (–40°F to +104°F)

– Factory Mutual (FM)
Transmitter with 4 to 20mA output signal and HART communication
 Intrinsically safe: Class I; Division 1; Groups A, B, C, D; Class I; Zone 0; Group IIC; AEx ia IIC
 Degree of protection : NEMA Type 4X (indoor or outdoor)

Permissible ambient temperature depending on temperature class

U _{max} = 30V, C _i = 10.5nF, L _i = 10μH			
Ambient Temperature	Temperature class	I _{max}	P _i
–40 to +85° C (–40 to +185° F)	T4	200mA	0.8W
–40 to +70° C (–40 to +129° F)	T4	200mA	1W
–40 to +40° C (–40 to +104° F)	T5	25mA	0.75W
–40 to +40° C (–40 to +104° F)	T6	25mA	0.5W

Fieldbus transmitters (PROFIBUS PA/FOUNDATION Fieldbus)
 Intrinsically Safe : Class I, II and III; Division 1; Groups A, B, C, D, E, F, G;
 Class I; Zone 0, AEx ia Group IIC T6; T4
 Non-incendive Class I, II and III, Division 2; Groups A, B, C, D, F, G

Transmitter with 4 to 20mA output signal and HART communication and Fieldbus transmitters (PROFIBUS PA/FOUNDATION Fieldbus)
 Explosion-Proof: Class I; Division 1; Groups A, B, C, D; Class II/III, Division 1; Groups E, F, G
 Degree of protection : NEMA Type 4X (indoor or outdoor)

– Canadian Standard (CSA)
Transmitter with 4 to 20mA output signal and HART communication and Fieldbus transmitters (PROFIBUS PA/FOUNDATION Fieldbus)
 Explosion-Proof: Class I; Division 1; Groups B, C, D
 Class II; Division 1; Groups E, F, G
 Class III
 Degree of protection : NEMA Type 4X (indoor or outdoor)

Electrical Characteristics and Options

HART digital communication and 4 to 20mA output

Power Supply

The transmitter operates from 10.5 to 45VDC with no load and is protected against reverse polarity connection (additional load allows operations over 45VDC).

Minimum power supply is 14VDC with backlit indicator.

For EEx ia and other intrinsically safe approval power supply must not exceed 30VDC.

Ripple

Maximum permissible voltage ripple of power supply during the communication:

7Vpp at f = 50 to 100Hz

1Vpp at f = 100 to 200Hz

0.2Vpp at f = 200 to 300Hz

Load limitations

4 to 20mA and HART total loop resistance :

$$R(k\Omega) = \frac{\text{Supply voltage} - \text{min. operating voltage (VDC)}}{22.5}$$

A minimum of 250Ω is required for HART communication.

Optional indicators

Integral display

2-line, 6-character 19-segment alphanumeric display with additional bar chart display, optionally with back illumination. User-specific display:

percentage of the output current or

output current in mA or

free process variable

Diagnostic message, alarms, measuring range infringements and changes in the configuration are also displayed.

Output signal

Two-wire 4 to 20mA, related to mass flow calculation, compensating all pressure (p) and temperature (T) effects completely.

HART® communication provides digital process variable (% , mA or engineering units) superimposed on 4 to 20mA signal, with protocol based on Bell 202 FSK standard.

Output function

Mass flow calculation performed as per formula:

$$Q_m \approx C \cdot E_v \cdot Y_1 \cdot d^2 \sqrt{dp \cdot \rho}$$

where

Q_m	= mass flowrate
C	= discharge coefficient
E_v	= velocity of approach factor
Y_1	= gas expansion factor
d	= bore diameter
dp	= differential pressure
ρ	= fluid density

Output current limits (to NAMUR standard)

Overload condition

- Lower limit: 3.8mA (configurable down to 3.5mA)

- Upper limit: 20.5mA (configurable up to 22.5mA)

Alarm current

Min. alarm current: configurable from 3.5mA to 4mA, standard setting: 3.6mA

Max. alarm current: configurable from 20mA to 22.5mA, standard setting: 21mA

Standard setting: max. alarm current

PROFIBUS PA output**Power supply**

The transmitter operates from 10.2 to 32VDC with no polarity.

For EEx ia approval power supply must not exceed 17.5VDC. Intrinsic safety installation according to FISCO model.

Current consumption

operating (quiescent): 11.7mA

fault current limiting: 17.3mA max.

Output signal

Physical layer in compliance to IEC 1158-2/EN 61158-2 with transmission to Manchester II modulation, at 31.25kbit/sec.

Output interface

PROFIBUS PA communication according to Profibus DP50170 Part 2/ DIN 19245 part 1-3 compliant to Profiles 3.0 Class A & B for pressure transmitter.

Output update time

40ms

Function blocks

3 analog input, 2 transducer, 1 physical

Integral display

2-line, 6-character 19-segment alphanumeric display with additional bar chart display, optionally with back illumination. User-specific display:

percentage of the output or

OUT (analog input function block)

Diagnostic message, alarms, measuring range infringements and changes in the configuration are also displayed.

Transmitter failure mode

Permanent self-diagnostic; possible errors indicated in diagnostic parameters and in the status of process values.

FOUNDATION Fieldbus output**Power supply**

The transmitter operates from 10.2 to 32VDC polarity independent.

For EEx ia approval power supply must not exceed 24VDC (entity certification) or 17.5VDC (FISCO certification), according to FF-816.

Current consumption

operating (quiescent): 11.7mA

fault current limiting: 17.3mA max.

Output signal

Physical layer in compliance to IEC 1158-2/EN 61158-2 with transmission to Manchester II modulation, at 31.25kbit/sec.

Function blocks/execution period

3 standard Analog Input blocks/250ms max (each)

Additional blocks

Transducer block, 1 standard Resource block,

1 custom Pressure with calibration block

Number of link objects

10

Number of VCRs

16

Output interface

FOUNDATION fieldbus digital communication protocol to standard H1, compliant to specification V. 1.5; FF registration in progress.

Integral display

2-line, 6-character 19-segment alphanumeric display with additional bar chart display, optionally with back illumination. User-specific display:

percentage of the output or

OUT (analog input function block)

Diagnostic message, alarms, measuring range infringements and changes in the configuration are also displayed.

Transmitter failure mode

Permanent self-diagnostic; possible errors indicated in diagnostic parameters and in the status of process values.

Performance specifications

Stated at reference condition to IEC 60770 ambient temperature of 20°C (68°F), relative humidity of 65%, atmospheric pressure of 1013hPa (1013mbar), mounting position with vertical diaphragm and zero based range for transmitter with isolating diaphragms in Hastelloy and silicone oil fill and HART digital trim values equal to 4–20mA span end points.

Unless otherwise specified, errors are quoted as % of span.

Some performance data are affected by the actual turndown (TD) as ratio between Upper Range Limit (URL) and calibrated span.

IT IS RECOMMENDED TO SELECT THE TRANSMITTER SENSOR CODE PROVIDING THE TURNDOWN VALUE AS LOWEST AS POSSIBLE TO OPTIMIZE PERFORMANCE CHARACTERISTICS.

Dynamic performance (according to IEC 61298–1 definition)

Standard configuration for instruments with turndown up to 30:1.

Dead time: 30ms

Time constant (63.2% of total step change):

– sensors F to N: 150ms

– sensor C: 400ms

– sensor A: 1000ms

Accuracy rating

% of calibrated span, including combined effects of terminal based linearity, hysteresis and repeatability.

For fieldbus versions SPAN refer to analog input function block outscale range

For differential pressure sensor

– $\pm 0.075\%$ for TD from 1:1 to 10:1

– $\pm(0.075 + 0.005 \times \frac{\text{URL}}{\text{Span}} - 0.05)\%$ for TD greater than 10:1

For absolute pressure sensor

– 0.1% URL of absolute pressure sensor

Operating influences

Ambient temperature (for turndown up to 15:1)

per 20K (36°F) change between the limits of –20°C to +65°C (–4 to +150°F)

for differential pressure sensor

– $\pm(0.04\% \text{ URL} + 0.065\% \text{ span})$

per 20K (36°F) change between the limits of –40°C to +80°C (–40°F to +176°F)

for absolute pressure sensor

– $\pm(0.08\% \text{ URL} + 0.08\% \text{ span})$

limited to $\pm(0.1\% \text{ URL} + 0.1\% \text{ span})$ per the complete temperature range of 120K (216°F)

Static pressure (zero errors can be calibrated out at line pressure)

Measuring range	Sensor A	Sensors C, F, L, N
on zero	up to 2bar: 0.05% URL	up to 100bar: 0.05% URL
	> 2bar: 0.05% URL/bar	> 100bar: 0.05%URL/100bar
on span	up to 2bar: 0.05% span	up to 100bar: 0.05% span
	> 2bar: 0.05% span/bar	> 100bar: 0.05%span/100bar

Supply voltage

Within voltage/load specified limits the total effect is less than 0.001% of URL per volt.

Load

Within load/voltage specified limits the total effect is negligible.

Radio frequency interference

Total effect : less than 0.05% of span from 20 to 1000MHz and for field strengths up to 10V/m when tested with unshielded conduit, with or without meter.

Common mode interference

No effect from 250Vrms @ 50Hz, or 50VDC

Mounting position

Rotations in plane of diaphragm have negligible effect. A tilt from vertical causes a zero shifts of $\sin \alpha \times 0.35\text{kPa}$ (3.5 mbar, 1.4inH₂O) of URL which can be corrected with the zero adjustment. No span effect.

Stability

$\pm 0.10\%$ of URL over a thirty-six-month period

Vibration effect

$\pm 0.10\%$ of URL (according to IEC 61298–3)

Physical Specification

(Refer to ordering information sheets for variant availability related to specific model or versions code)

Materials

Process isolating diaphragms (*)

AISI 316 L ss; Hastelloy C276™; Monel 400™; Tantalum;

Process flanges, adapters, plugs and drain/vent valves (*)

AISI 316 L ss; Hastelloy C276™; Monel 400™, Kynar (PVDF)

Sensor fill fluid

Silicone oil; inert fill (Carbon Fluoride).

Mounting bracket (**)

AISI 316 L ss.

Gaskets (*)

Viton™; Perbunan (NBR); EPDM;

PTFE (for sensors C, F, L, N) or FEP coated Viton™ (for sensor A)

Sensor housing

AISI 316 L ss.

Bolts and nuts

Stainless steel bolts and nuts Class A4–70 per ISO 3506, in compliance with NACE MR0175 Class II.

Electronic housing and covers

Barrel version

– Low-copper content aluminium alloy with baked epoxy finish;

– AISI 316 L ss.

DIN version

– Low-copper content aluminium alloy with baked epoxy finish.

Covers O-ring

Viton™.

Local zero and span adjustments

Glass filled polycarbonate plastic (removable).

Tagging

AISI 316ss or plastic data plate attached to the electronics housing.

Calibration

Standard: at maximum span, zero based range, ambient temperature and pressure;

Optional: at specified range and ambient conditions.

Optional extras

Mounting brackets

For vertical and horizontal 50mm. (2in) pipes or wall mounting.

Integral display

plug-in rotatable LCD indicator.

Supplemental customer tag

AISI 316 ss tag fastened to the transmitter with stainless steel wire for customer's tag data up to a maximum of 30 characters and spaces.

Cleaning procedure for oxygen service

Hydrogen preparation

Test Certificates (test, design, calibration, material traceability)

Tag and manual language

Communication connectors

Process connections

on flanges: 1/4in NPT on process axis selectable with 7/16in–20 UNF fixing threads or DIN 19213 connection with M10 fixing threads for working pressure up to 16MPa, 160bar, 2320psi or M12 fixing threads for greater working pressure up to 41MPa, 410bar, 6000psi

on adapters: 1/2in NPT on process axis

centre distance: 54mm (2.13in) on flange;

51,54 or 57mm (2.01, 2.13 or 2.24in) as per adapters fittings.

Electrical connections

Two 1/2 NPT or M20x1.5 threaded conduit entries, direct on housing.

Special communication connector (on request)

– HART : straight or angle Harting HAN connector and one plug.

– FOUNDATION Fieldbus and PROFIBUS PA: M12x1 or 7/8.

Terminal block

HART version: four terminals for signal/external meter plus four terminals for RTD connection wiring up to 2.5mm² (14AWG) and four connection points for test and communication purposes.

Fieldbus versions: two terminals for signal (bus connection) plus four terminals for RTD connection wiring up to 2.5mm² (14AWG).

Grounding

Internal and external 4mm² (12AWG) ground termination points are provided.

Mounting position

Transmitter can be mounted in any position.

Electronics housing may be rotated to any position. A positive stop prevents over travel.

Mass (without options)

3.5kg approx (8lb); add 1.5kg (3.4lb) for AISI housing.

Add 650g (1.5lb) for packing.

Packing

Carton 23 x 25 x 27cm approx (9 x 10 x 11in).

Configuration

Transmitter with HART communication and 4 to 20 mA

Standard configuration

Transmitters are factory calibrated to customer's specified range. Calibrated range and tag number are stamped on the type plate. If calibration range and tag data are not specified, the transmitter will be supplied configured as follows:

4 mA	Zero
20 mA	Upper Range Limit (URL)
Output	Linear
Damping	0.125s
Transmitter failure mode	21mA

Any or all the above configurable parameters, including Lower range-value and Upper range-value which must be the same unit of measure, can be easily changed by a PC running the configuration software Smart Vision with DTM for 2600T.

The transmitter database is customized with specified flange type and material, o-ring and filling liquid.

Transmitter with PROFIBUS PA communication

Transmitters are factory calibrated to customer's specified range. Calibrated range and tag number are stamped on the type plate. If calibration range and tag data are not specified, the transmitter will be supplied configured as follows:

Measure Profile	Pressure
Engineering Unit	mbar/bar
Output scale 0%	Lower Range Limit (LRL)
Output scale 100%	Upper Range Limit (URL)
Output	Linear
Hi-Hi Limit	Upper Range Limit (URL)
Hi Limit	Upper Range Limit (URL)
Low Limit	Lower Range Limit (LRL)
Low-Low Limit	Lower Range Limit (LRL)
Limits hysteresis	0.5% of output scale
PV filter	0.125s.
Address	126

Any or all the above configurable parameters, including Lower range-value and Upper range-value which must be the same unit of measure, can be easily changed by a PC running the configuration software Smart Vision with DTM for 2600T.

The transmitter database is customized with specified flange type and material, o-ring and filling liquid.

Transmitter with FOUNDATION Fieldbus communication

Transmitters are factory calibrated to customer's specified range. Calibrated range and tag number are stamped on the type plate. If calibration range and tag data are not specified, the transmitter will be supplied configured as follows:

Measure Profile	Pressure
Engineering Unit	mbar/bar
Output scale 0%	Lower Range Limit (LRL)
Output scale 100%	Upper Range Limit (URL)
Output	Linear
Hi-Hi Limit	Upper Range Limit (URL)
Hi Limit :	Upper Range Limit (URL)
Low Limit	Lower Range Limit (LRL)
Low-Low Limit	Lower Range Limit (LRL)
Limits hysteresis	0.5% of output scale
PV filter	0.125s
Address	Not necessary

Any or all the above configurable parameters, including lower range value and upper range value which must be the same unit of measure, can be changed by any FOUNDATION Fieldbus compatible configurator.

The transmitter database is customized with specified flange type and material, o-ring and filling liquid.

™ Hastelloy is a Cabot Corporation trademark

™ Monel is an International Nickel Co. trademark

™ Viton is a Dupont de Nemour trademark

(*) Wetted parts of the transmitter.

(**) U-bolt material: AISI 400 ss; screws material: AISI 316 ss.

MOUNTING DIMENSIONS (not for construction unless certified) – dimensions in mm (in)
Transmitter with barrel housing

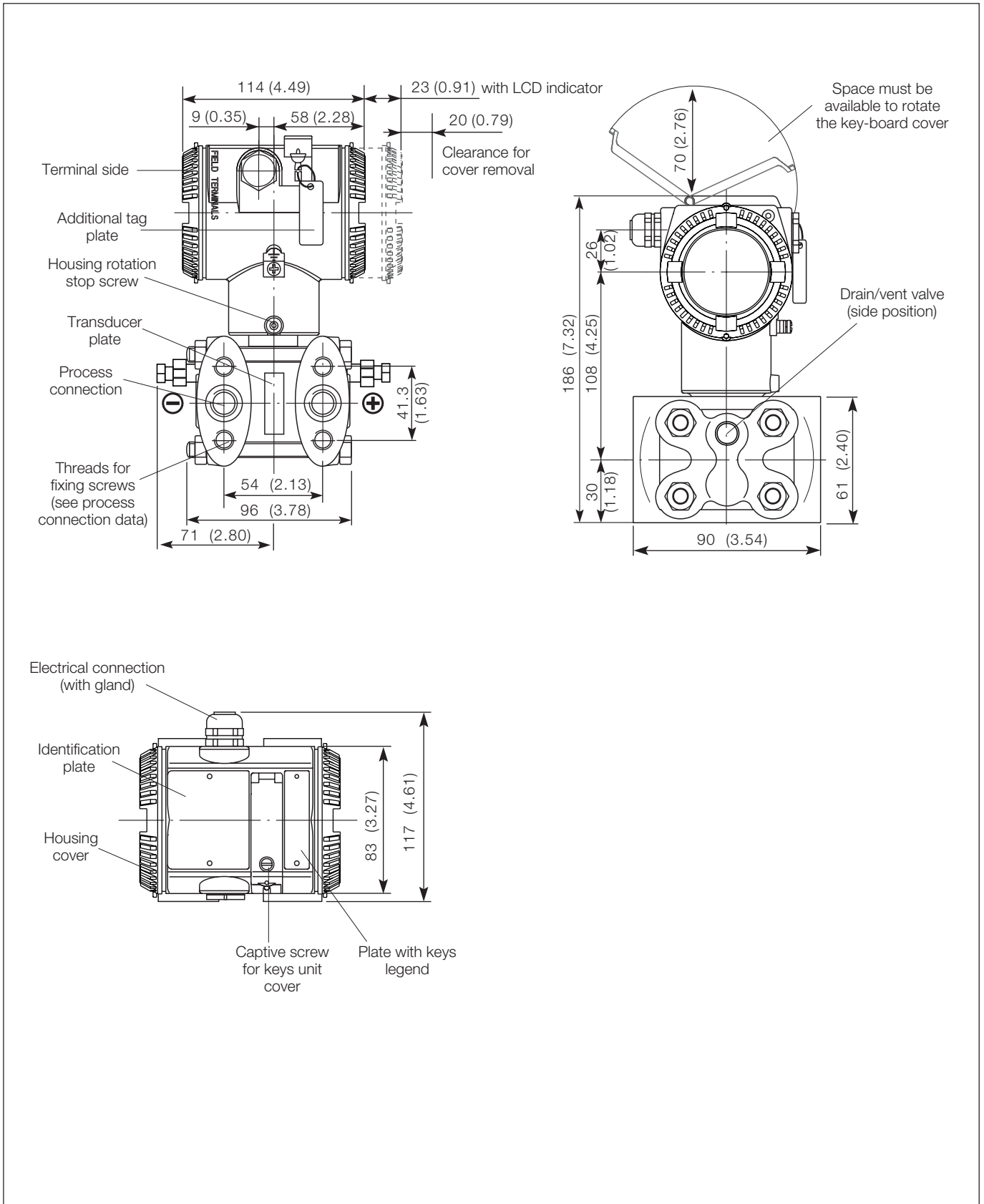

Transmitter with DIN housing

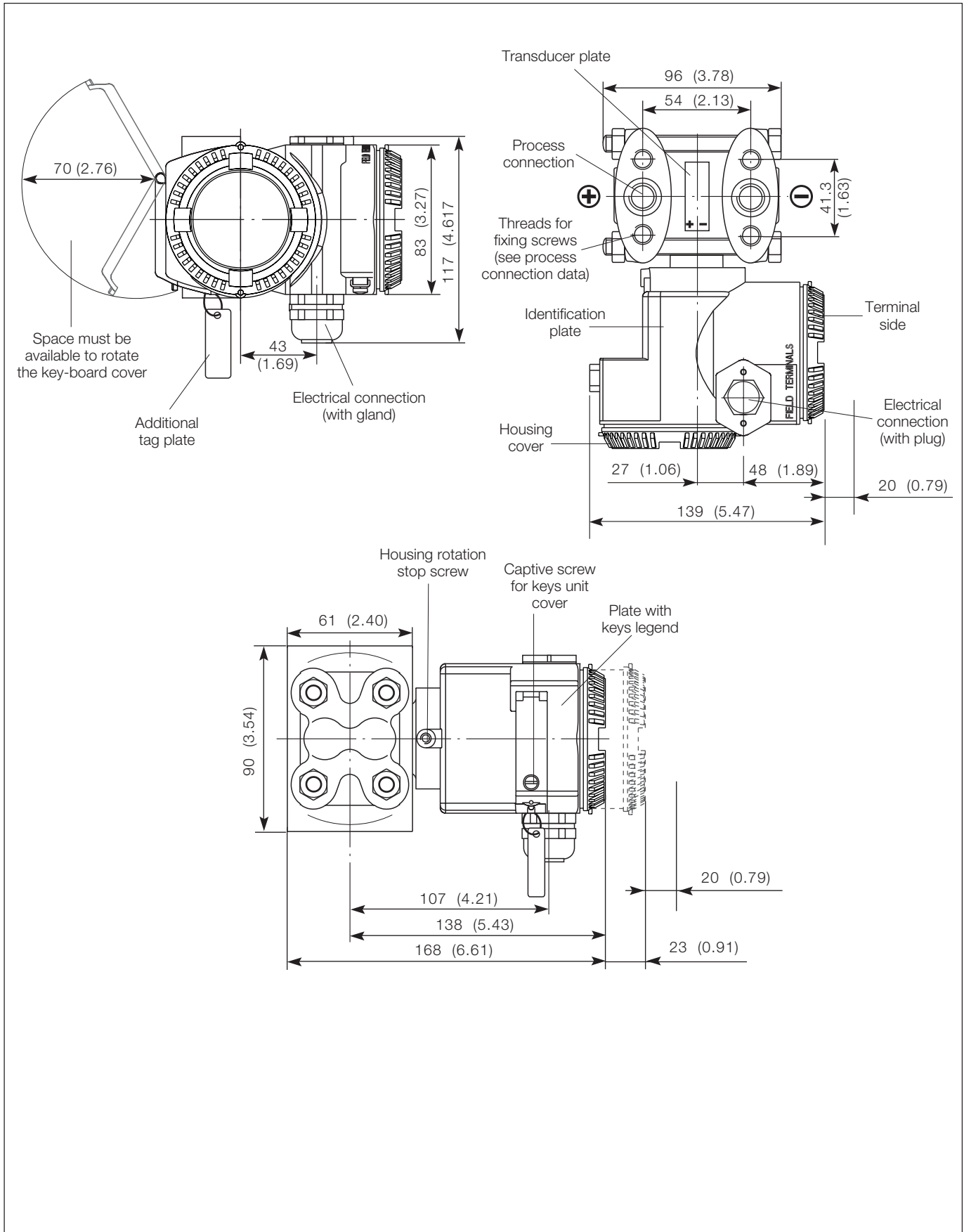

Possible mounting with bracket

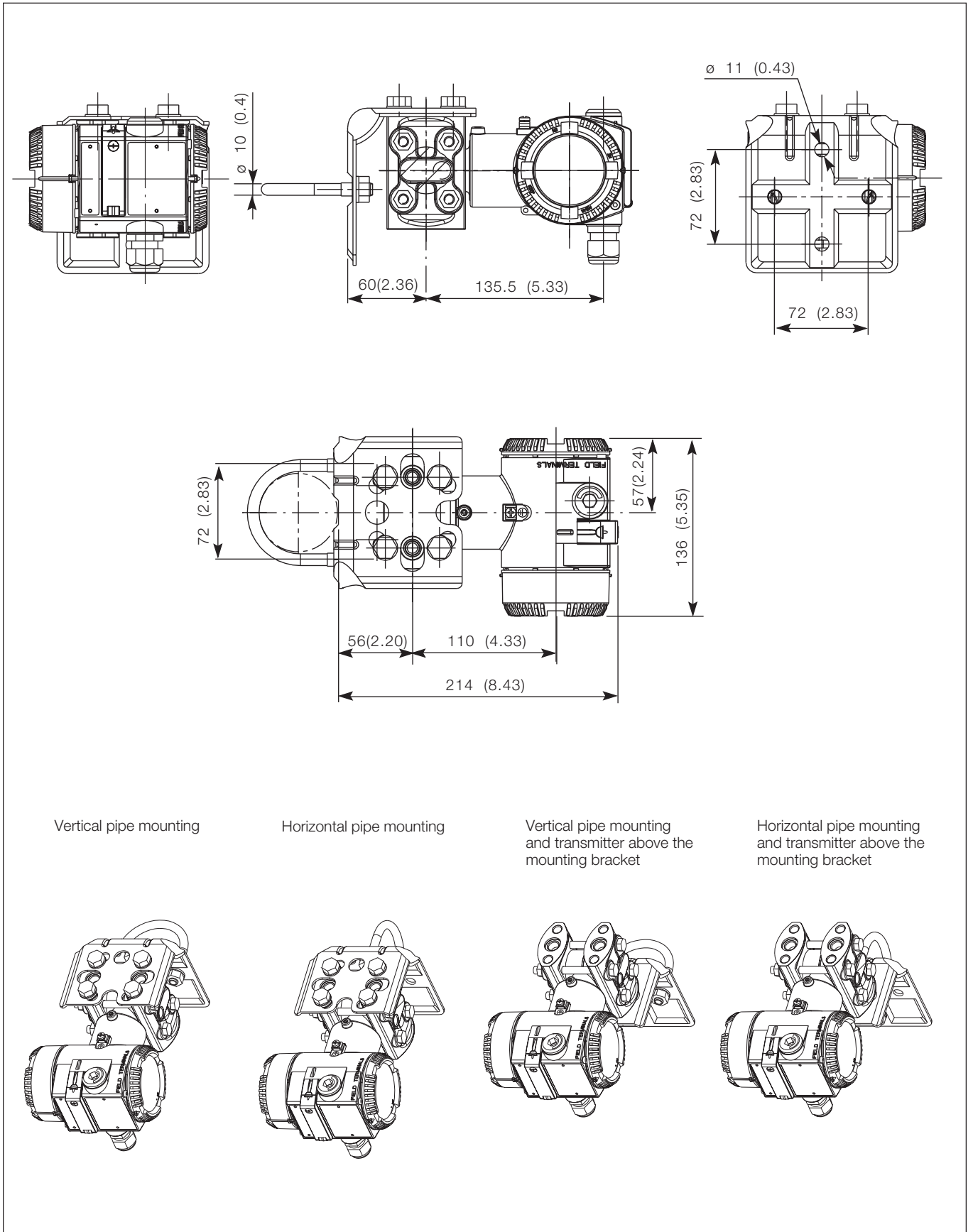

Electrical connections

Standard Terminal block

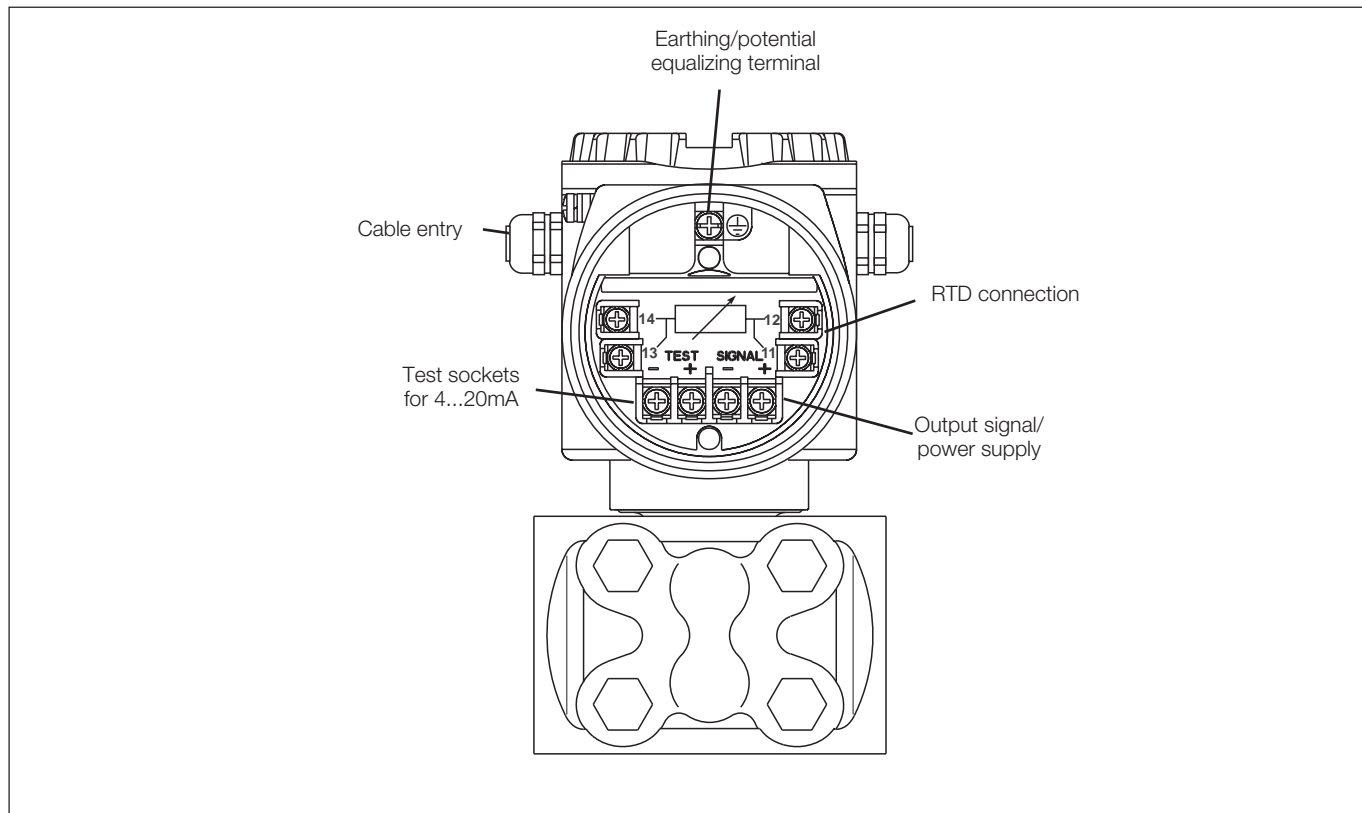

Harting HAN connector

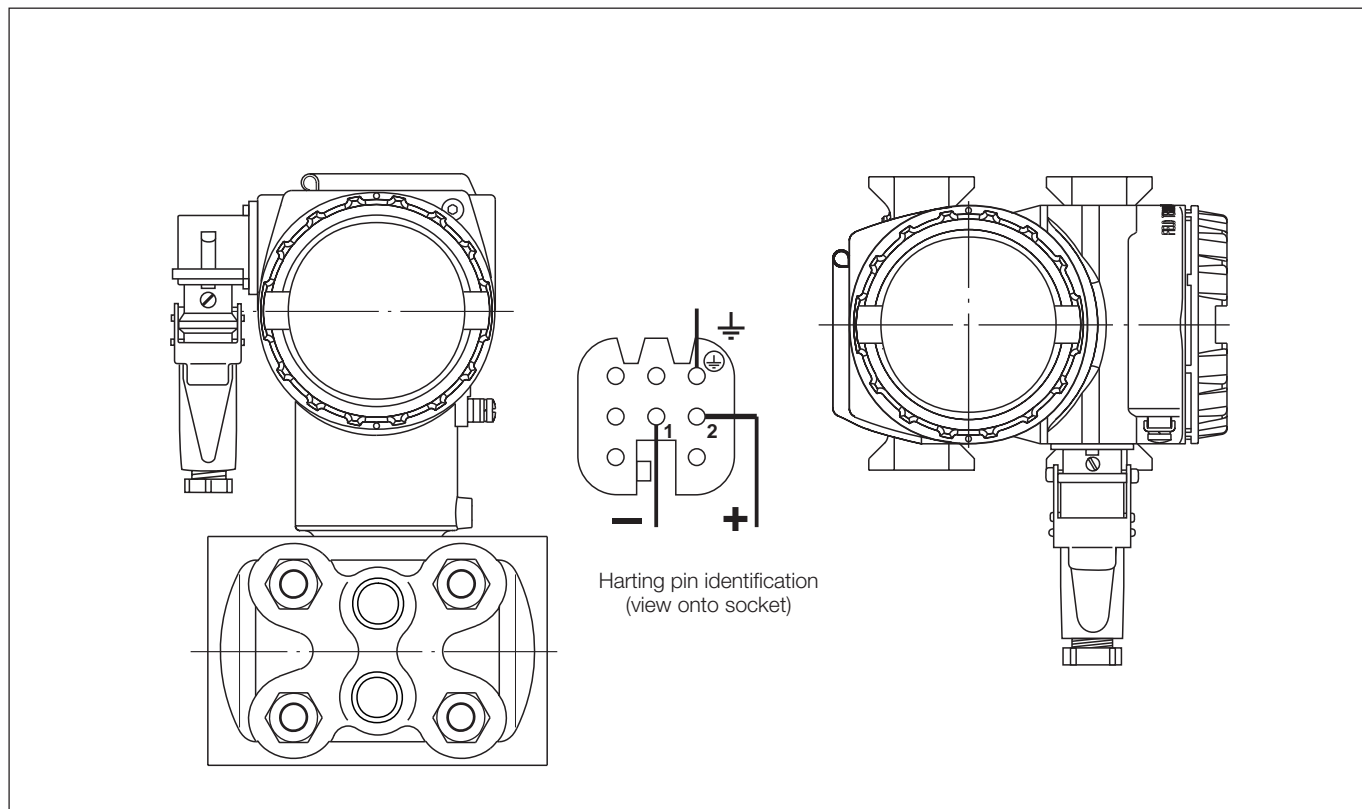

BASIC ORDERING INFORMATION model 267CS Multivariable Transmitter for mass flow

Select one character or set of characters from each category and specify complete catalog number.
Refer to additional ordering information code and specify one or more codes for each transmitter if additional options are required.

BASE MODEL – 1 st to 5 th characters				2	6	7	C	S	X	X	X	X	X	X	X
Multivariable transmitter for mass flow – BASE ACCURACY 0.075%															
SENSOR - Span limits – 6th character															
0.05 and 1kPa	0.5 and 10mbar	0.2 and 4inH ₂ O							A						
0.2 and 6 kPa	2 and 60mbar	0.8 and 24inH ₂ O							C						
0.4 and 40kPa	4 and 400mbar	1.6 and 160inH ₂ O							F						
2.5 and 250kPa	25 and 2500mbar	10 and 1000inH ₂ O							L						
20 and 2000kPa	0.2 and 20bar	2.9 and 290psi							N						
Static pressure range – 7th character															
0 to 0.6MPa	0 to 6bar	0 to 87psi		(Note 1)							1				
0 to 2MPa	0 to 20bar	0 to 290psi		(Note 2)							2				
0 to 10MPa	0 to 100bar	0 to 1450psi		(Note 2)							3				
0 to 41MPa	0 to 410bar	0 to 5945psi		(Note 2)							4				
Diaphragm material / Fill fluid (wetted parts) – 8th character															
AISI 316 L ss	Silicone oil								NACE	S					
Hastelloy C276™	Silicone oil								NACE	K					
Monel 400™	Silicone oil								NACE	M					
Monel 400™g old plated	Silicone oil								NACE	V					
Tantalum	Silicone oil								NACE	T					
AISI 316 L ss	Inert fluid		(Note 3)						NACE	A					
Hastelloy C276™	Inert fluid		(Note 3)						NACE	F					
Monel 400™	Inert fluid		(Note 3)						NACE	C					
Monel 400™ gold plated	Inert fluid		(Note 3)						NACE	Y					
Tantalum	Inert fluid		(Note 3)						NACE	D					
Process flanges/adapters material and connection (wetted parts) – 9th character															
AISI 316 L ss (Horizontal connection)	1/4in NPT-f direct (1/16in UNF U.S. drilling)								NACE	A					
AISI 316 L ss (Horizontal connection)	1/4in NPT-f direct (DIN 19213)								NACE	C					
AISI 316 L ss (Horizontal connection)	1/2in NPT-f through adapter (1/16in UNF U.S. drilling)								NACE	B					
Hastelloy C276™ (Horizontal connection)	1/4in NPT-f direct (1/16in UNF U.S. drilling)								NACE	D					
Hastelloy C276™ (Horizontal connection)	1/4in NPT-f direct (DIN 19213)								NACE	F					
Hastelloy C276™ (Horizontal connection)	1/2in NPT-f through adapter (1/16in UNF U.S. drilling)								NACE	E					
Monel 400™ (Horizontal connection)	1/4in NPT-f direct (1/16in UNF U.S. drilling)								NACE	G					
Monel 400™ (Horizontal connection)	1/4in NPT-f direct (DIN 19213)								NACE	L					
Monel 400™ (Horizontal connection)	1/2in NPT-f through adapter (1/16in UNF U.S. drilling)								NACE	H					
Kynar (PVDF) (MWP=1MPa) (Horizontal connection)	1/4in NPT-f direct (1/16in UNF U.S. drilling)								NACE	P					
Bolts/Gasket (wetted parts) – 10th character															
Stainless steel (NACE)	Viton™		(Note 3)						NACE				3		
Stainless steel (NACE)	PTFE (MWP 10MPa)								NACE				4		
Stainless steel (NACE)	EPDM								NACE				5		
Stainless steel (NACE)	Perbunan												6		
Housing material and electrical connection – 11th character															
Aluminium alloy (Barrel version)	1/2in NPT													A	
Aluminium alloy (Barrel version)	M20 x 1.5 (CM 20)		(Not available FM, CSA)											B	
Aluminium alloy (Barrel version)	Harting HAN connector		(Note 4) (Not available, ATEX EExd, FM, CSA)											E	
Aluminium alloy (Barrel version)	Fieldbus connector		(Note 4) (Not available, ATEX EExd, FM, CSA)											G	
AISI 316 L ss (Barrel version)	1/2in NPT													S	
AISI 316 L ss (Barrel version)	M20 x 1.5 (CM20)		(Not available FM, CSA)											T	
Aluminium alloy (DIN version)	M20 x 1.5 (CM 20)		(Not available FM, CSA)											J	
Aluminium alloy (DIN version)	Harting HAN connector		(Note 4) (Not available, ATEX EExd, FM, CSA)											K	
Aluminium alloy (DIN version)	Fieldbus connector		(Note 4) (Not available, ATEX EExd, FM, CSA)											W	
Output/Additional options – 12th character															
HART digital communication and 4 to 20mA	No additional options								(Notes 5, 6)					H	
HART digital communication and 4 to 20mA	Options requested (to be ordered by "Additional ordering code")								(Note 5)					1	
PROFIBUS PA	No additional options								(Notes 5, 6)					P	
PROFIBUS PA	Options requested (to be ordered by "Additional ordering code")								(Note 6)					2	
FOUNDATION Fieldbus	No additional options								(Notes 5, 6)					F	
FOUNDATION Fieldbus	Options requested (to be ordered by "Additional ordering code")								(Note 6)					3	
Modbus RS485	No additional options								(Notes 5, 6)					M	
Modbus RS485	Options requested (to be ordered by "Additional ordering code")								(Notes 5, 6)					5	
Modbus RS232	No additional options								(Notes 5, 6)					N	
Modbus RS232	Options requested (to be ordered by "Additional ordering code")								(Notes 5, 6)					6	

ADDITIONAL ORDERING INFORMATION for model 267CS

Add one or more 2-digit code(s) after the basic ordering information to select all required options

	XX	XX	XX	XX	XX	XX	XX	XX	XX	XX	XX
Drain/vent valve (material and position) (wetted parts)											
AISI 316 L ss on process axis (Note 7) NACE V1											
AISI 316 L ss on flange side top (Note 7) NACE V2											
AISI 316 L ss on flange side bottom (Note 7) NACE V3											
Hastelloy C276™ on process axis (Note 8) NACE V4											
Hastelloy C276™ on flange side top (Note 8) NACE V5											
Hastelloy C276™ on flange side bottom (Note 8) NACE V6											
Monel 400™ on process axis (Note 9) NACE V7											
Monel 400™ on flange side top (Note 9) NACE V8											
Monel 400™ on flange side bottom (Note 9) NACE V9											
Electrical certification											
ATEX Group II Category 1/2 GD – Intrinsic Safety EEx ia										E1	
ATEX Group II Category 1/2 G – Flameproof EEx d										E2	
ATEX Group II Category 3 GD – Type of protection "N" EEx nL design compliance										E3	
Factory Mutual (FM) – Intrinsically Safe										EA	
Factory Mutual (FM) – Explosion Proof (only with 1/2in NPT electrical connection and stainless steel label)										EB	
Canadian Standard Association – Intrinsically Safe										ED	
Canadian Standard Association – Explosion Proof										EE	
Integral LCD											
Digital LCD integral display										L1	
Backlit digital LCD integral display										L2	
Mounting bracket (shape and material)											
For pipe mounting AISI 316 L ss										B2	
For wall mounting AISI 316 L ss										B4	
Operating manual											
German										M1	
Labels & tag language											
German in stainless steel (not available with DIN Electronic Housing code J, K, W)										T1	
German and English plastic (not suitable for Factory Mutual - Explosion Proof)										TA	
Additional tag plate											
In stainless steel										I1	
Preparation procedure											
Oxygen service cleaning (only available with inert fill) – Pmax = 12MPa/120bar/1740psi; Tmax = 60° C/140° F										P1	
Hydrogen service preparation										P2	
Certificates											
Inspection certificate EN 10204–3.1.B of calibration										C1	
Inspection certificate EN 10204–3.1.B of the cleanliness stage according to DIN 25410										C3	
Inspection certificate EN 10204–3.1.B of helium leakage test of the sensor module										C4	
Inspection certificate EN 10204–3.1.B of the pressure test										C5	
Certificate of compliance with the order EN 10204–2.1 of instrument design										C6	
Material traceability											
Certificate of compliance with the order EN 10204–2.1 of process wetted parts										H1	
Inspection certificate EN 10204–3.1.B of process wetted parts										H3	
Test report EN 10204-2.2 of the pressure bearing and process wetted parts										H4	
Connector											
Fieldbus 7/8 (Notes 6, 10)										U1	
Fieldbus M12x1 (Notes 6, 10)										U2	
Harting HAN – straight entry (Notes 5, 10)										U3	
Harting HAN – angle entry (Notes 5, 11)										U4	

- Note 1: Not available with sensor code C, F, L, N
- Note 2: Not available with sensor code A
- Note 3: Suitable for oxygen service
- Note 4: Select type in additional ordering code
- Note 5: Not available with Electronic Housing code G and W
- Note 6: Not available with Electronic Housing code E and K
- Note 7: Not available with Process flanges/adapters code D, E, F, G, H, L, P
- Note 8: Not available with Process flanges/adapters code A, B, C, G, H, L, P
- Note 9: Not available with Process flanges/adapters code A, B, C, D, E, F, P
- Note 10: Not available with Electronic housing code T, S, A, B, J
- Note 11: Not available with Electronic housing code T, S, A, B, J, K.

™ Hastelloy is a Cabot Corporation trademark

™ Monel is an International Nickel Co. trademark

™ Viton is a Dupont de Nemour trademark

Standard delivery items (can be differently specified by additional ordering code)

- Adapters supplied loose
- Plug on axis (no drain/vent valves)
- General purpose (no electrical certification)
- No meter/display, no mounting bracket
- English manual and labels (stainless steel nameplate for Barrel housing code A, B, E, G, S, T; plastic nameplate for DIN housing code J, K, W)
- Configuration with kPa and deg. C units
- No test, inspection or material traceability certificates

THE SELECTION OF SUITABLE WETTED PARTS AND FILLING FLUID FOR COMPATIBILITY WITH THE PROCESS MEDIA IS A CUSTOMER'S RESPONSIBILITY, IF NOT OTHERWISE NOTIFIED BEFORE MANUFACTURING.