

Model 130 Electrical: Installation and Operating Instructions

ELECTRICAL

Gauges with switches have one or two hermetically sealed adjustable set point reed switch assemblies. Load ratings and capabilities for each switch type are defined as follows:

REED SWITCH RATINGS (Resistive Load)

Type	SPDT
Option:	A
*Power	3W
Max. Current	0.25 Amps
Max. Voltage VAC/VDC	125
**Setting (%F.S.)	10 to 90
Hysteresis (Max/Nom) (F.S.)	10% / 5%
Repeatability	1% F.S.
Leads 22 Awg.	(3), 26"

- * Product of the switching voltage and current shall not exceed the power rating of the device.

The following warnings apply to all gauge options with electrical interface:



WARNING: ELECTRICAL CONNECTIONS SHOULD BE PERFORMED BY QUALIFIED PERSONNEL AND MEET THE REPRESENTATIVE COUNTRY'S NATIONAL ELECTRICAL CODE.

WARNING: FAILURE TO CONNECT TO THE PROTECTIVE CONDUCTOR TERMINAL MAY RESULT IN A SHOCK HAZARD.

WARNING: REMOVAL OR REPLACEMENT OF INSTRUMENT HARDWARE VOIDS ALL WARRANTIES AND CONFORMANCE TO ANY STANDARDS (EXCEPT COVERS AND/OR SWITCH ADJUST PLUG(S))

The SPDT switch ('A' Electrical Option) lead colors and associated functionality at '0' PSID is shown in Figure 1. The SPDT switch is adjustable within the range of 10% to 90% F.S. To increase the set point rotate switch adjustment screw counter clockwise (CCW). **Do not use excessive force when rotating the adjustment screw or the adjustment mechanism may be damaged.**

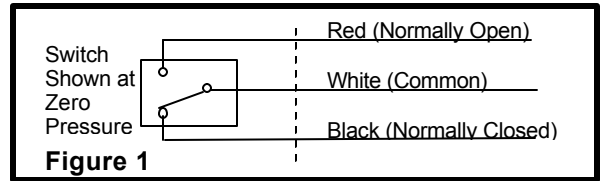

Provide standard protection techniques for the switch contacts for capacitive and inductive loads. Use current limiting techniques near the switch to protect the contacts due to high inrush (i.e.; in line resistor or inductor) for long cable interfaces. Provide clamping devices at or near inductive loads (i.e.; relay). **Maximum wire length between the 3W switch and its load, should not exceed 70 – 100 Feet. for 120 VAC applications.** Contact the factory for assistance regarding this condition.

Use the Mid-West Power Relay 1000TR or equivalent relay for loads above the switch rating.

CONDULET ENCLOSURE (Standard) (Options H & I)

The standard switch enclosure is a conduit with 1/2" FNPT interface. On orders that do not require wall or pipe mounting the flying leads exit the rear of the gauge. For the remaining orders the wires exit the side of the gauge. You may re-route the wires out the back of the gauge by removing the switch access cover and relocating the conduit pipe plug to the side conduit port. See Fig. 2.

To access the switch adjustment screws, remove the cover from the conduit. Make adjustments as necessary using a screwdriver.

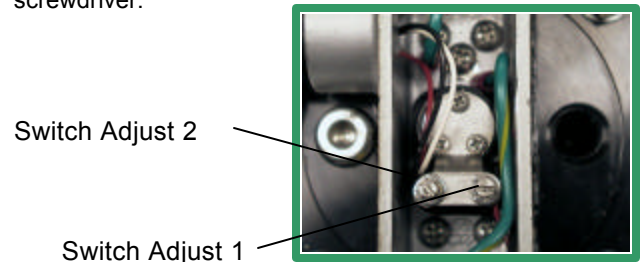

A provision to connect a protective conductor terminal is also provided. The Green / Yellow wire is provided for shock safety.

The 26 Awg., 300 Volt rated, flying leads are color coded and labeled as follows:

White- 1 or 2 Com
 Black- 1 or 2 NC
 Red - 1 or 2 NO

Deviations from the above configurations may exist. Therefore check the description block of your order to verify your configuration.

DIN Plug-in Connector (Condulet Housing)
(Options J & K)



WARNING: REMOVE POWER PRIOR TO MAKING ADJUSTMENTS. USE AN OHM METER OR EQUIVALENT DEVICE TO MONITOR SWITCH CONTACTS WHILE MAKING ADJUSTMENTS.

The DIN interface conforms to DIN 43 650A / ISO 4400 and **when mated** provides an IP65 rated protection class. The right angle mating connector is supplied with the gauge upon order. Clocking (orientation) can be changed by prying out the insert and rotating the insert to the desired clocking (90 ° increments).

Wiring for the SPDT switch(es) is as follows :

1. - **Common**
 2. - **N.C.**
 3. - **N.O.**
-  - **Chassis**

For a single switch order the connector will be located out the side of the gauge. For a double switch order, two separate connector interfaces are provided; side and rear. The side connector will interface to the low set point and the rear connector will interface to the high set point. The double switch unit can only be horizontally pipe mounted.

 A protective conductor terminal is provided on the DIN connector.

NEMA 4X (Weatherproof Enclosure)
(Options L & M)



The gauge and switch(es) are mounted inside the enclosure with the switch(es) wired to a seven (7) position terminal strip. The terminal strip connection uses 6-32 screws and is rated for use with wire up to 14 Awg.. An opening is provided on the bottom of the enclosure for a 1/2" flexible cable or conduit connection.

Access the terminal strip by removing the cover from the enclosure and loosening the (4) screws. Insert wires through an appropriate weatherproof connector (not supplied) into the enclosure and connect to the terminal strip. See the terminal strip diagram shown below or on the outside of the switch enclosure. Reinstall the cover and (4) screws. See Figure 3.

Access holes and plugs are provided for external adjustment of the switches if required.

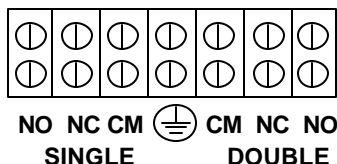

NEMA 7 (Explosion-proof) Enclosure
(Options N & P)



WARNING: THE COVER AND/OR SWITCH ADJUST ACCESS PLUGS MUST NEVER BE REMOVED WHEN THERE IS POWER TO THE UNIT. MAKE ALL ADJUSTMENTS IN A NON HAZARDOUS AREA.

The gauge and switches are mounted inside the enclosure (see Fig. 4). A 1/2"-14 FNPT conduit connection is provided in the bottom side of the enclosure. A proper explosion-proof, dust tight sealing fitting with appropriate sealing cement must be used when making connections to the 24", 18 Awg. wire leads. The leads are labeled and/or color coded as described in the condulet section.

Adjustment of the set point can be accomplished by removing the switch adjustment access plug(s). Insert the screw driver through the hole into the switch adjustment slot and rotate until the desired set point is reached. **Do not use excessive force.** Reinstall the access plugs with **at least 5 threads of engagement** after completion.

Enclosures with SPDT switches comply with NEC Class 1, Groups **C & D**, Class 2 Groups E,F, & G, NEMA 7 and 9, and **are** CSA and UL listed.

TROUBLE SHOOTING

A. Switch doesn't function

- i. Make sure that the switch load does not exceed the specified wattage rating of the switch. (steady-state and transient). Contact factory for assistance for excessive loads, otherwise proceed to the next step.
- ii. Perform a continuity check of the switch contacts by trying to actuate the switch using an external magnet. An operational switch usually indicates a problem with the gauge. If not operational proceed to the next step.
- iii. Verify the reed switch wires are connected to the terminal strip (NEMA 4X enclosure only). Contact the factory for assistance if the switch is connected and/or request an "RGA".

B. Gauge accuracy and set point problems:

- i. Verify gauge is not in an electromagnetic / magnetic environment. i.e.; close proximity to high current power lines.
- ii. All others, contact the factory for assistance.

MOUNTING INFORMATION & DIMENSIONAL DATA

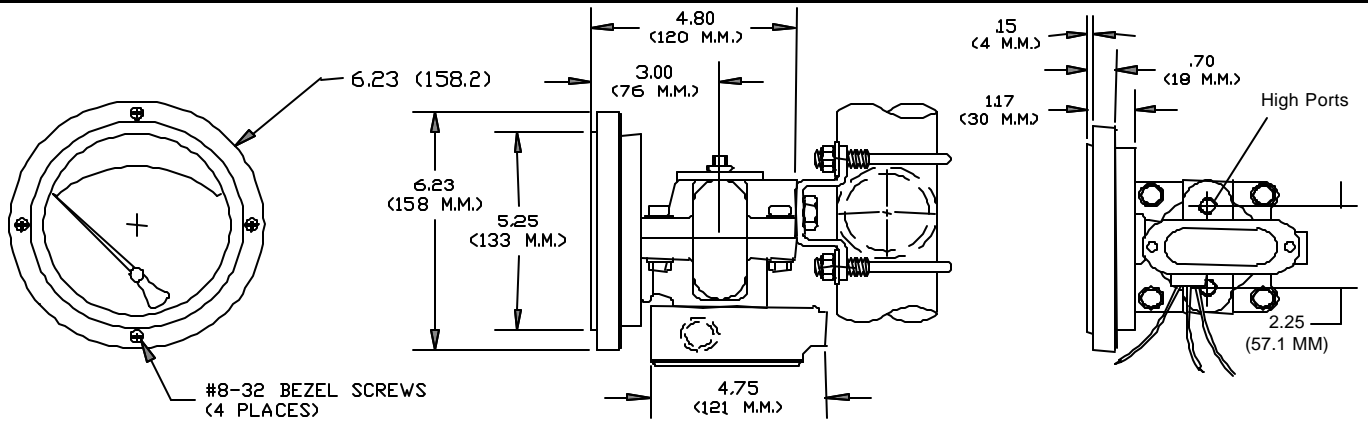

FIGURE 2
Model 130-S
Options: H & I

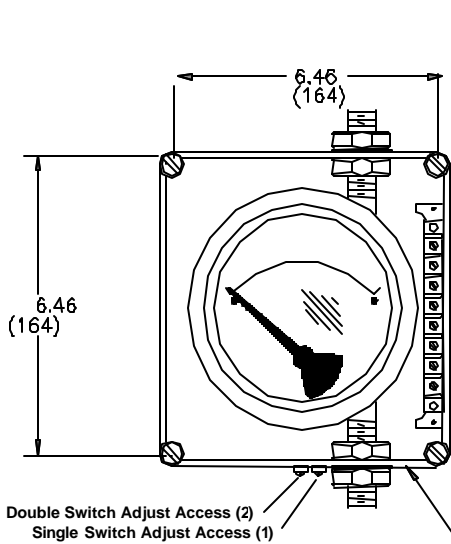

FIGURE 3
NEMA 4X Options L & M

Installation Instructions:

1. Remove Lid
2. Install #10 Pan Head or 1/4" Socket Head Screw and Mount to Panel. (Parts supplied by customer)

Double Switch Connections

Single Switch Connections

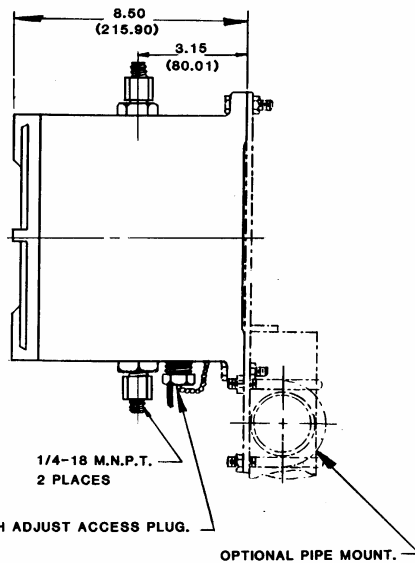
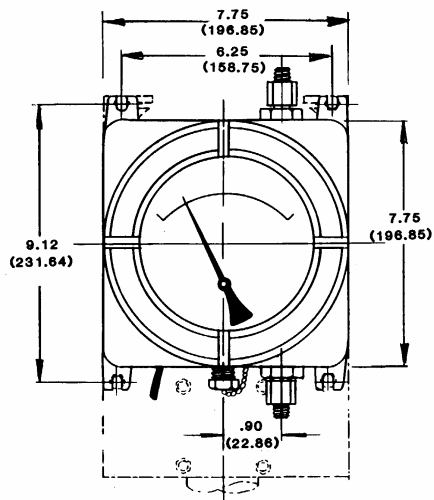
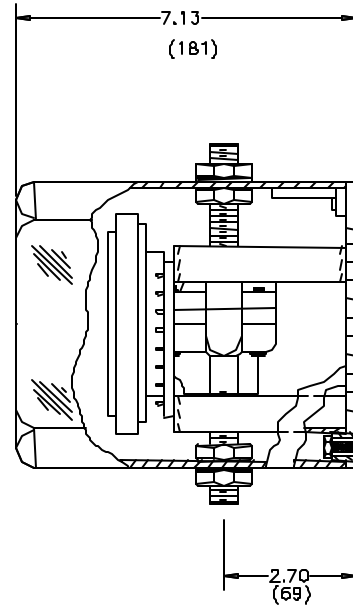

NOTE :

1. DRAWINGS SHOW STANDARD GAUGE NOMINAL DIMENSIONS.
2. DIMENSIONS SHOWN IN PARENTHESES ARE IN MILLIMETERS.



FIGURE 3
Explosion-proof
Options: N & P
CSA & UL Listed

PART NUMBERING SYSTEM

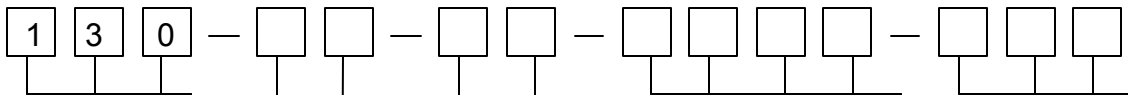

① BASIC MODEL NUMBER

② MATERIAL

- A. Aluminum (3000 P.S.I.G.)
- B. Brass (1500 P.S.I.G.)
- H. Hastelloy C. (500 P.S.I.G.)
- S. 316 S.S. (3000 P.S.I.G.)
- Z. Special

③ DIAL SIZE

- C. 4-1/2" Round Dial (Standard)
- E. 3-1/2" Round Anod. Alum. Dial Assy.
- G. 4-1/2" Round Anod. Alum. Dial Assy.
- T. Differential Pressure Switch Only (Without Indication).
(Selection Appropriate Electrical Options)
- Z. Special (Uncoded Options)

④ SEALS & DIAPHRAGM MATERIAL

- 0. Buna N (Standard)
- 1. Viton®
- 2. Silicone
- 5. Ethylene Propylene (0-5" H₂O THRU 0-100" H₂O MAX.)
- 9. Special (Uncoded Options)

⑤ CONNECTIONS

- 0. 1/4" C.S. Comp. Tube Ftgs. (2) Model P or 1/4" FNPT (4) for Models A, B, & S
- 1. 1/4" 316 S.S. Comp. Tube Ftgs (2).
- 2. 1/4" FNPT Brass Adapters (2) (Model P Only)
- 3. 1/4" FNPT 316 S.S. Adapters (2) (Model P Only)
- 4. 1/2" FNPT S.S. Adaptors (2) (All Models Except P)
- 9. Special (Uncoded Options)

⑥ OPTIONS (Up to four options)

- O. None
- B. Drain & Bleed Plugs, 316 Stainless Steel (2) (Model 130 P)
- D. Drain & Bleed For Model 130 P in NEMA 4X Enclosure
- E. Drain & Bleed For all other Model 130's in NEMA 4X Enclosure
- F. Pipe Mounting Kit
- M. Maximum Indicator Follower Pointer
- T. Oxygen Cleaning
- U. S.S. Tag w/S.S. Wire
- V. S.S. Tag w/S.S. Screws
- W. Wall Mounting Kit
- Z. Special (Uncoded Options)

NOTE: NOT ALL OPTIONS AVAILABLE IN COMBINATION WITH OTHER OPTIONS.

⑦ ELECTRICAL CONFIGURATIONS

(Switch Adjustable Range 10-90% except where stated below)

- O. None
- H. One (1) Reed Switch in Condulet Enclosure
- I. Two (2) Reed Switches in Condulet Enclosure
- J. One (1) Reed Switch in Condulet Enclosure and Plug-In
- K. Two(2) Reed Switches in Condulet Enclosure and Plug-In Connector (DIN 43650- PG11)
- L. One (1) Reed Switch in NEMA4X Plastic Enclosure
- M. Two (2) Reed Switches in NEMA4X Plastic Enclosure
- N. One (1) Reed Switch in Explosion-proof enclosure with glass window cover and C.S.A. & UL Listing ⁽¹⁾
- P. Two (2) Reed Switches in Explosion-proof enclosure with glass window cover and C.S.A. & UL Listing ⁽¹⁾
- Z. Special

(1) Complete Assembly Rated Class I, Div. 1, Groups C & D; Class II, Div. 1, Groups E, F, & G.

⑧ ELECTRICAL SPECIFICATIONS

- A. S.P.D.T., 3 Watts, 0.25 Amp, 125 VAC/VDC
- Z. Special

Manufacturer reserves the right to change specifications without prior notice.

Temperature Limitations: -40° F (-40° C) to +200° F (+93° C)

Proof Pressure: Two times rated working pressure.