

Technical Information 2006	unit	Reference Vessel TDR-3 PN16	01.04.2006
	type series		page 1

base equipment reference vessel type TDR-3

version	:	communicating vessel for built-in of measuring-systems
installation	:	vertical
measuring length (section 2.1)	:	max. 5000 mm (single-piece constr.) > 5000 mm (2- or multiparts) (section 4)
vessel diameter (section 2)	:	60,3 x 2 mm (1.4571/ 316Ti) 60,3 x 2,9 mm (St35.8/ A 106A) 88,9 x 2 mm (1.4571/ 316Ti) 88,9 x 3,2 mm (St35.8/ A 106A)
process connection (section 3)	:	optionally welding or threaded stud flange DN15 up to DN80 PN16 (PN40) flange ½" up to 3" 150# (300#)
drain connection (section 6)	:	plug R½" (add. options s. section 6.2)
material of vessel (section 2)	:	1.4571 (316Ti) St35.8 (A 106A) other materials on request
flange material (section 3.4)	:	1.4571 (316Ti) St35.8 (A 106A) other materials on request
oper. temperature	:	-50 up to +400 °C (1.4571/ 316Ti) -10 up to +400 °C (St35.8/ A 106A)
oper. pressure	:	max. 16 bar
bolts/ nuts (section 6.6)	:	CS (max. 300°C) SS (-60 up to +300 °C) Ck35/C35 (A194 Gr 2) ^x 21CrMoV57/ 24CrMo5 (A193 Gr B) ^x ^x max. 400°C)
gaskets (section 6.7)	:	PTFE up to 100 °C Klingsil C4400 up to 175 °C Graphit spiral wounded up to 400 °C ^{***}
standard dim.	:	A= 172* B= 82** C= 60*** E= 12

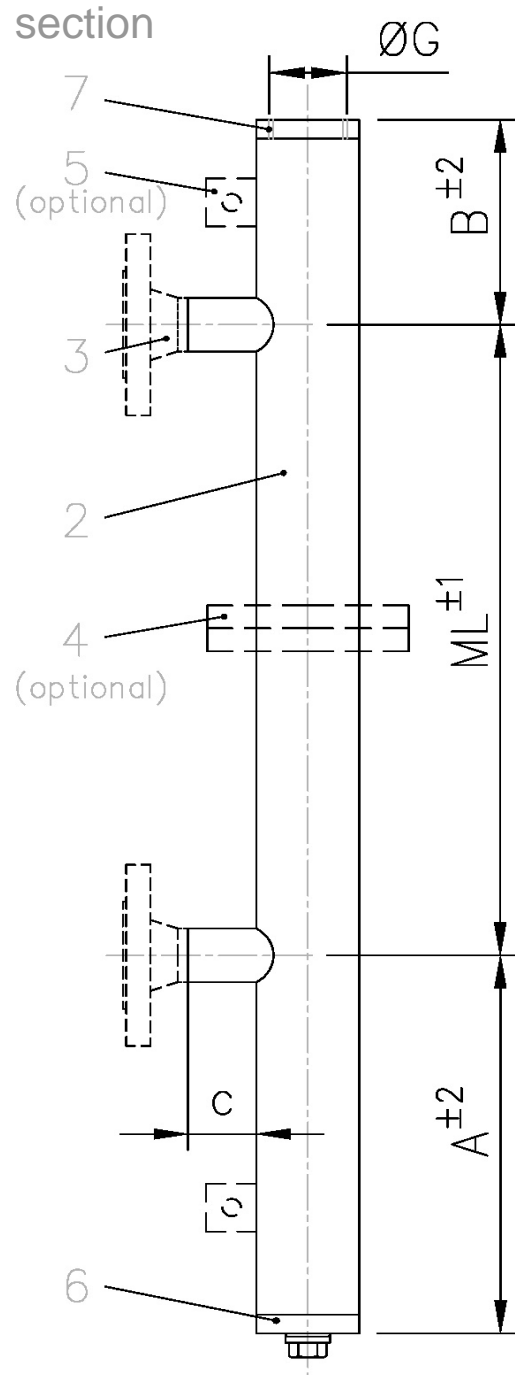

Base equipment printed bold!

* for flanged connection: A= 70 + height of flange

** for flanged connection: B= 160 + height of flange

*** only in combination with drain-flange ≥ DN50 or 2"; then C= 60 + height of flange

Specification reference vessel type		TDR-3		page 2	
TDR-	1. Base type	<i>pressure rating</i>			
3	vertical mounting	PN 16	150 lbs		
	2. Reference vessel				
	<i>material</i>	<i>vessel diam.</i>	<i>dimension</i>		
S0	316Ti (1.4571)	DN50/ 2"	Ø60,3x2,0mm		
C0	CS (St 35.8)	DN50/ 2"	Ø60,3x2,9mm		
S4	316Ti (1.4571)	DN80/ 3"	Ø88,9x2,0mm		
C3	CS (St 35.8)	DN80/ 3"	Ø88,9x3,2mm		
Y2	other				
	2.1 measuring length (please specify)	<i>vessel diam.</i>	<i>material</i>		
M00	center/ center process connection in mm (or inch)	DN50/ 2"	1.4571		
M09	center/ center process connection in mm (or inch)	DN50/ 2"	C-Stahl		
M04	center/ center process connection in mm (or inch)	DN80/ 3"	1.4571		
M12	center/ center process connection in mm (or inch)	DN80/ 3"	C-Stahl		
Y3	other				
	3. Process connection (1 pair)				
1	side/ side				
Y4	other				
	3.1 rule type				
D	in acc. to DIN				
A	in acc. to ANSI				
Y5	other				
	3.2 connection type				
S	welding stud				
	3.3 connection form				
	<i>please specify dimension & welding bevel</i>				
N	ripple				
M	sleeve				
	3.3 connection form				
	<i>DIN</i>				
R	thread form R				
G	thread form G				
	<i>ANSI</i>				
N	thread form NPT				
Y7	other				
	3.4 connection size	<i>material</i>			
A01	1/2"	as vessel			
A11	3/4"	as vessel			
A21	1"	as vessel			
A31	1 1/4"	as vessel			
A41	1 1/2"	as vessel			
A51	2"	as vessel			
Y8	other	as vessel			
	3.5 connection surface				
	00	without			
F	flange	316Ti or CS			
Y6	other				
	3.3 connection form				
V	welding neck flange				
L	lap joint flange				
Y7	other				
	3.4 connection size	<i>material</i>			
	<i>DIN</i>				
	<i>DN</i>	<i>PN</i>	<i>ANSI</i>	<i>material</i>	
			<i>DN</i>	<i>lbs</i>	
C01	DN15	PN16	1/2"	150	CS
C02	DN15	PN40	1/2"	300	CS
C11	DN20	PN16	3/4"	150	CS
C12	DN20	PN40	3/4"	300	CS
C21	DN25	PN16	1"	150	CS
C22	DN25	PN40	1"	300	CS
C31	DN32	PN16	1 1/4"	150	CS
C32	DN32	PN40	1 1/4"	300	CS
C41	DN40	PN16	1 1/2"	150	CS
C42	DN40	PN40	1 1/2"	300	CS
C51	DN50	PN16	2"	150	CS
C52	DN50	PN40	2"	300	CS
C61	DN80	PN16	3"	150	CS
C62	DN80	PN40	3"	300	CS
S01	DN15	PN16	1/2"	150	316Ti
S02	DN15	PN40	1/2"	300	316Ti
S11	DN20	PN16	3/4"	150	316Ti
S12	DN20	PN40	3/4"	300	316Ti
S21	DN25	PN16	1"	150	316Ti
S22	DN25	PN40	1"	300	316Ti
S31	DN32	PN16	1 1/4"	150	316Ti
S32	DN32	PN40	1 1/4"	300	316Ti
S41	DN40	PN16	1 1/2"	150	316Ti
S42	DN40	PN40	1 1/2"	300	316Ti
S51	DN50	PN16	2"	150	316Ti
S52	DN50	PN40	2"	300	316Ti
S61	DN80	PN16	3"	150	316Ti
S62	DN80	PN40	3"	300	316Ti
Y8	other				

Specification reference vessel type	TDR-3	-continued-	page 3
3.5 connection surface		material	
<i>DIN</i>			
C0	form C, DIN 2526	316Ti or CS	
D0	form D, DIN 2526	316Ti or CS	
E0	form E, DIN 2526	316Ti or CS	
NC	form N, DIN 2526	CS	
NS	form N, DIN 2526	316Ti	
FC	form F, DIN 2526	CS	
FS	form F, DIN 2526	316Ti	
<i>ANSI</i>		material	
RF	ANSI RF	316Ti or CS	
SF	ANSI RF SF	316Ti or CS	
JC	ANSI RTJ	CS	
JS	ANSI RTJ	316Ti	
Y9	other		
4. Flanged connection for measuring length>5000mm		vessel diam.	material
V00	without, for measuring length<5000mm		316Ti or CS
V51	DN50 PN16	DN50/ 2"	CS
V52	DN50 PN16	DN50/ 2"	316Ti
V61	DN80 PN16	DN80/ 3"	CS
V62	DN80 PN16	DN80/ 3"	316Ti
Y10	other		
5. Support brackets		<i>x= quantity (please specify)</i>	material
H0	without		
HCx	support brackets (plate with 2 bore holes)		CS
HSx	support brackets (plate with 2 bore holes)		316Ti
6. Drain connection			
E	end cap with plug		
F	flange		
6.1 rule type			
D	in acc. to DIN		
A	in acc. to ANSI		
Y11	other		
6.2 drain type		material	
0	for end cap	as vessel	
6.3 type			
<i>DIN</i>			
R	thread form R		
G	thread form G		
<i>ANSI</i>			
N	thread form NPT		
Y13	other		
6.4 size of thread		material	
G01	1/2"	CS	
G11	3/4"		
G21	1"		
G02	1/2"	316Ti	
G12	3/4"		
G22	1"		
Y14	other	other	
6.5			
0	not defined		
6.6			
0	not defined		
6.7			
0	not defined		
6.2 type with blindflange		<i>DIN</i>	<i>PN</i>
A31	blindflange	DN32	PN16
A32	blindflange	DN32	PN16
A41	blindflange	DN50	PN16
A42	blindflange	DN50	PN16
A43	welding neck flange	DN50	PN16
A44	welding neck flange	DN50	PN16
A51	blindflange	DN80	PN16
A52	blindflange	DN80	PN16
A53	welding neck flange	DN80	PN16
A54	welding neck flange	DN80	PN16
Y12	other		
6.3 form		material	
<i>DIN</i>			
C0	form C, DIN 2526	316Ti or CS	
D0	form D, DIN 2526	316Ti or CS	
E0	form E, DIN 2526	316Ti or CS	
NC	form N, DIN 2526	CS	
NS	form N, DIN 2526	316Ti	
FC	form F, DIN 2526	CS	
FS	form F, DIN 2526	316Ti	
<i>DIN</i>			
R0	ANSI RF	316Ti or CS	
S0	ANSI RF SF	316Ti or CS	
JC	ANSI RTJ	CS	
JS	ANSI RTJ	316Ti	
Y13	other		

Specification reference vessel type	TDR-3	-continued-	page 4				
6.4 drain plug							
0	without						
P	plugged						
Y14	other						
6.5 thread type							
0	without plug						
DIN							
R	thread form R						
G	thread form G						
ANSI							
N	thread form NPT						
Y15	other						
6.5 plug size							
0	without plug		material				
S01	1/2"	CS					
S11	3/4"						
S21	1"						
S01	1/2"	316Ti					
S11	3/4"						
S21	1"						
Y16	other						
6.6 screw connection (DIN/ANSI)							
C01	bolts/nuts; mat. SS		temp.-range max. 300 °C				
C01	bolts/nuts; mat. CS		-60 to +300 °C				
C11	bolts/nuts; mat. Ck35/C35 (A194 Gr 2)		-50 to +400 °C				
C12	bolts/nuts; mat. 21CrMoV57/24CrMo5 (A193 Gr B)		max. 400 °C				
Y17	other						
6.7 gasket (DIN/ANSI)							
P	PTFE		temp.-range max. 100 °C				
T	Klingersil C4400		max. 175 °C				
S	Graphit/ spiral wounded		max. 400 °C				
K	Graphit/ cam profile		max. 400 °C				
Y18	other						
7. Instruments connection for measuring equipment							
E	end cap with thread						
F	flange						
7.1 rule type							
D	in acc. to DIN						
A	in acc. to ANSI						
Y19	other						
7.2 type of instruments connection							
0	for end cap		material as vessel				
7.3 form							
DIN							
R	thread form R						
G	thread form G						
ANSI							
N	thread form NPT						
Y20	other						
7.4 connection size							
G1	3/4"		material as vessel				
G3	1 1/2"		as vessel				
Y21	other						
7.2 type							
I41	blindflange	DN50	PN16	2"	150	DN50/ 2"	CS
I42	blindflange	DN50	PN16	2"	150	DN50/ 2"	316Ti
I43	welding neck flange	DN50	PN16	2"	150	DN50/ 2"	CS
I44	welding neck flange	DN50	PN16	2"	150	DN50/ 2"	316Ti
I51	blindflange	DN80	PN16	3"	150	DN80/ 3"	CS
I52	blindflange	DN80	PN16	3"	150	DN80/ 3"	316Ti
I53	welding neck flange	DN80	PN16	3"	150	DN80/ 3"	CS
I54	welding neck flange	DN80	PN16	3"	150	DN80/ 3"	316Ti
Y22	other						
7.3 form							
DIN							
C0	form C, DIN 2526		316Ti or CS				
D0	form D, DIN 2526		316Ti or CS				
E0	form E, DIN 2526		316Ti or CS				
NC	form N, DIN 2526		CS				
NS	form N, DIN 2526		316Ti				
FC	form F, DIN 2526		CS				
FS	form F, DIN 2526		316Ti				
ANSI							
R0	ANSI RF		316Ti or CS				
S0	ANSI RF SF		316Ti or CS				
JC	ANSI RTJ		CS				
JS	ANSI RTJ		316Ti				
Y23	other						

Technical Information 2006	unit	Reference Vessel TDR-6 PN40	01.04.2006
	type		page 5
	series		

base equipment reference vessel type TDR-6

version	:	communicating vessel for built-in of measuring-systems
installation	:	vertical
measuring length (section 2.1)	:	max. 5000 mm (single-piece constr.) > 5000 mm (2- or multiparts) (section 4)
vessel diameter (section 2)	:	60,3 x 2 mm (1.4571/ 316Ti) 60,3 x 2,9 mm (St35.8/ A 106A) 88,9 x 3,2 mm (1.4571/ 316Ti) 88,9 x 3,2 mm (St35.8/ A 106A)
process connection (section 3)	:	optionally welding or threaded stud flange DN15 up to DN80 PN40
drain connection (section 6)	:	plug R½" (add. options s. section 6.2)
material of vessel (section 2)	:	1.4571 (316Ti) St35.8 (A 106A) other materials on request
flange material (section 3.4)	:	1.4571 (316Ti) St35.8 (A 106A) other materials on request
oper. temperature	:	-50 up to +400 °C (1.4571/ 316Ti) -10 up to +400 °C (St35.8/ A 106A)
oper. pressure	:	max. 40 bar
bolts/ nuts (section 6.6)	:	CS (max. 300°C) SS (-60 to +300 °C) Ck35/C35 (A194 Gr 2) ^x 21CrMoV57/ 24CrMo5 (A193 Gr B) ^x ^x max. 400°C)
gaskets (section 6.7)	:	PTFE up to 100 °C Klingsil C4400 up to 175 °C Graphit spiral wounded up to 400 °C ^{***}
standard dim.	:	A= 172* B= 82** C= 60*** E= 12

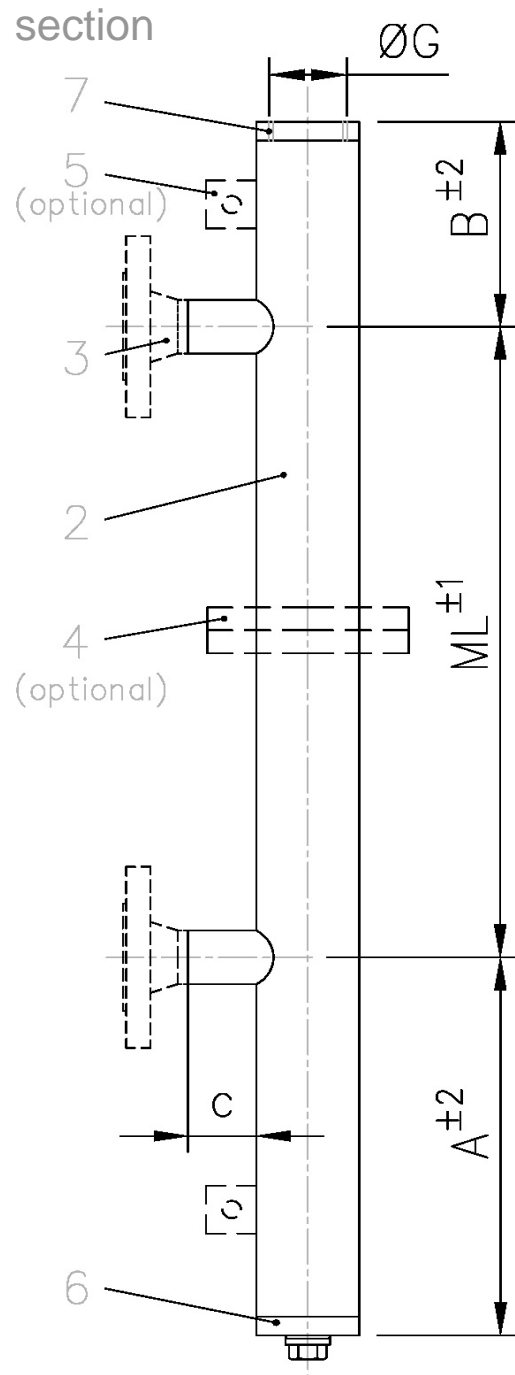

Base equipment printed bold!

* for flanged connection: A= 70 + height of flange

** for flanged connection: B= 160 + height of flange

*** only in combination with drain-flange ≥ DN50 or 2"; then C= 60 + height of flange

TDR-	1. Base type	<i>pressure rating</i>	
	6	vertical mounting	PN 40
	2. Reference vessel		
		<i>material</i>	<i>vessel diam.</i> <i>dimension</i>
	S0	316Ti (1.4571)	DN50/ 2" Ø60,3x2,0mm
	C0	CS (St 35.8)	DN50/ 2" Ø60,3x2,9mm
	S5	316Ti (1.4571)	DN80/ 3" Ø88,9x3,2mm
	C3	CS (St 35.8)	DN80/ 3" Ø88,9x3,2mm
	Y2	other	
		2.1 measuring length (please specify)	<i>vessel diam.</i> <i>material</i>
	M00	center/ center process connection in mm (or inch)	DN50/ 2" 1.4571
	M09	center/ center process connection in mm (or inch)	DN50/ 2" C-Stahl
	M05	center/ center process connection in mm (or inch)	DN80/ 3" 1.4571
	M12	center/ center process connection in mm (or inch)	DN80/ 3" C-Stahl
	Y3	other	
	3. Process connection (1 pair)		
	1	side/ side	
	Y4	other	
	3.1 rule type		
	D	in acc. to DIN	
	A	in acc. to ANSI	
	Y5	other	
	3.2 connection type		
	S	welding stud	
	3.3 connection form		
		<i>please specify dimension & welding bevel</i>	
	N	nipple	
	M	sleeve	
	3.3 connection form		
		<i>DIN</i>	
	R	thread form R	
	G	thread form G	
	<i>ANSI</i>		
	N	thread form NPT	
	Y7	other	
	3.4 connection size		<i>material</i>
	A01	1/2"	as vessel
	A11	3/4"	as vessel
	A21	1"	as vessel
	A31	1 1/4"	as vessel
	A41	1 1/2"	as vessel
	A51	2"	as vessel
	Y8	other	
	3.5 connection surface		
		00	<i>without</i>
	F	flange	316Ti or CS
	Y6	other	
	3.3 connection form		
	V	welding neck flange	
	L	lap joint flange	
	Y7	other	
	3.4 connection size		<i>material</i>
		<i>DIN</i>	
		<i>DN</i>	<i>PN</i>
	C02	DN15	PN40
	C12	DN20	PN40
	C22	DN25	PN40
	C32	DN32	PN40
	C42	DN40	PN40
	C52	DN50	PN40
	C62	DN80	PN40
	S02	DN15	PN40
	S12	DN20	PN40
	S22	DN25	PN40
	S32	DN32	PN40
	S42	DN40	PN40
	S52	DN50	PN40
	S62	DN80	PN40
	Y8	other	

Specification reference vessel type	TDR-6	-continued-	page 7
3.5 connection surface			material
DIN			
C0	form C, DIN 2526		316Ti or CS
D0	form D, DIN 2526		316Ti or CS
E0	form E, DIN 2526		316Ti or CS
NC	form N, DIN 2526		CS
NS	form N, DIN 2526		316Ti
FC	form F, DIN 2526		CS
FS	form F, DIN 2526		316Ti
ANSI			material
RF	ANSI RF		316Ti or CS
SF	ANSI RF SF		316Ti or CS
JC	ANSI RTJ		CS
JS	ANSI RTJ		316Ti
Y9	other		
4. Flanged connection for measuring length > 5000mm			vessel diam.
V00	without, for measuring length < 5000mm		316Ti or CS
V53	DN50 PN40	DN50/ 2"	CS
V54	DN50 PN40	DN50/ 2"	316Ti
V63	DN80 PN40	DN80/ 3"	CS
V64	DN80 PN40	DN80/ 3"	316Ti
Y10	other		
5. Support brackets			material
<i>x = quantity (please specify)</i>			
H0	without		
HCx	support brackets (plate with 2 bore holes)		CS
HSx	support brackets (plate with 2 bore holes)		316Ti
6. Drain connection			
E	end cap with plug		
F	flange		
6.1 rule type			
D	in acc. to DIN		
A	in acc. to ANSI		
Y11	other		
6.2 drain type			material
0	for end cap		as vessel
6.3 type			
DIN			
R	thread form R		
G	thread form G		
ANSI			
N	thread form NPT		
Y13	other		
6.4 size of thread			material
G01	1/2"		
G11	3/4"		CS
G21	1"		
G02	1/2"		
G12	3/4"		316Ti
G22	1"		
Y14	other		other
6.5			
0	not defined		
6.6			
0	not defined		
6.7			
0	not defined		
6.2 type with blindflange			material
B31	blindflange	DN32 PN40	DN50/ 2" CS
B32	blindflange	DN32 PN40	DN50/ 2" 316Ti
B41	blindflange	DN50 PN40	DN50/ 2" CS
B42	blindflange	DN50 PN40	DN50/ 2" 316Ti
B43	welding neck flange	DN50 PN40	DN50/ 2" CS
B44	welding neck flange	DN50 PN40	DN50/ 2" 316Ti
B51	blindflange	DN80 PN40	DN80/ 3" CS
B52	blindflange	DN80 PN40	DN80/ 3" 316Ti
B53	welding neck flange	DN80 PN40	DN80/ 3" CS
B54	welding neck flange	DN80 PN40	DN80/ 3" 316Ti
Y12	other		
6.3 form			material
DIN			
C0	form C, DIN 2526		316Ti or CS
D0	form D, DIN 2526		316Ti or CS
E0	form E, DIN 2526		316Ti or CS
NC	form N, DIN 2526		CS
NS	form N, DIN 2526		316Ti
FC	form F, DIN 2526		CS
FS	form F, DIN 2526		316Ti
DIN			
R0	ANSI RF		316Ti or CS
S0	ANSI RF SF		316Ti or CS
JC	ANSI RTJ		CS
JS	ANSI RTJ		316Ti
Y13	andere		

6.4 drain plug		
0	without	
P	plugged	
Y14	other	
6.5 thread type		
0	without plug	
DIN		
R	thread form R	
G	thread form G	
ANSI		
N	thread form NPT	
Y15	other	
6.5 plug size		material
0	without plug	
S01	1/2"	CS
S11	3/4"	
S21	1"	
S01	1/2"	316Ti
S11	3/4"	
S21	1"	
Y16	other	
6.6 screw connection (DIN/ANSI)		temp.-range
C01	bolts/nuts; mat. SS	max. 300 °C
C01	bolts/nuts; mat. CS	-60 up to +300 °C
C11	bolts/nuts; mat. Ck35/C35 (A194 Gr 2)	-50 up to +400 °C
C12	bolts/nuts; mat. 21CrMoV57/24CrMo5 (A193 Gr B)	max. 400 °C
Y17	other	
6.7 gasket (DIN/ANSI)		temp.-range
P	PTFE	max. 100 °C
T	Klingersil C4400	max. 175 °C
S	Graphit/ spiral wounded	max. 400 °C
K	Graphit/ cam profile	max. 400 °C
Y18	other	

7. Instruments connection for measuring equipment				
E	end cap with thread			
F	flange			
7.1 rule type				
D	in acc. to DIN			
A	in acc. to ANSI			
Y19	other			
7.2 type of instruments connection		material		
0	for end cap	as vessel		
7.3 form				
DIN				
R	thread form R			
G	thread form G			
ANSI				
N	thread form NPT			
Y20	other			
7.4 connection size		material		
G1	3/4"	as vessel		
G3	1 1/2"	as vessel		
Y21	other			
7.2 type	DIN	PN	vessel diam.	material
K41	blindflange	DN50 PN40	DN50/ 2"	CS
K42	blindflange	DN50 PN40	DN50/ 2"	316Ti
K43	welding neck flange	DN50 PN40	DN50/ 2"	CS
K44	welding neck flange	DN50 PN40	DN50/ 2"	316Ti
K51	blindflange	DN80 PN40	DN80/ 3"	CS
K52	blindflange	DN80 PN40	DN80/ 3"	316Ti
K53	welding neck flange	DN80 PN40	DN80/ 3"	CS
K54	welding neck flange	DN80 PN40	DN80/ 3"	316Ti
Y22	other			
7.3 form		material		
DIN				
C0	form C, DIN 2526	316Ti or CS		
D0	form D, DIN 2526	316Ti or CS		
E0	form E, DIN 2526	316Ti or CS		
NC	form N, DIN 2526	CS		
NS	form N, DIN 2526	316Ti		
FC	form F, DIN 2526	CS		
FS	form F, DIN 2526	316Ti		
ANSI		material		
R0	ANSI RF	316Ti or CS		
S0	ANSI RF SF	316Ti or CS		
JC	ANSI RTJ	CS		
JS	ANSI RTJ	316Ti		
Y23	other			

Technical Information 2006	unit	Reference Vessel TDR-7 PN64	01.04.2006
	type series		page 9

base equipment reference vessel type TDR-7

version	:	communicating vessel for built-in of measuring-systems
installation	:	vertical
measuring length (section 2.1)	:	max. 5000 mm (single-piece constr.) > 5000 mm (2- or multiparts) (section 4)
vessel diameter (section 2)	:	60,3 x 2,9 mm (1.4571/ 316Ti) 60,3 x 2,9 mm (St35.8/ A 106A) 88,9x 4 mm (1.4571/ 316Ti) 88,8 x 4 mm (St35.8/ A 106A)
process connection (section 3)	:	optionally welding or threaded flange DN15 up to DN80 PN64 flange ½" up to 3" 300#
drain connection (section 6)	:	plug G½" (add. options s. section 6.2)
material of vessel (section 2)	:	1.4571 (316Ti) St35.8 (A 106A) other materials on request
flange material (section 3.4)	:	1.4571 (316Ti) St35.8 (A 106A) other materials on request
oper. temperature	:	-50 up to +400 °C (1.4571/ 316Ti) -10 up to +400 °C (St35.8/ A 106A)
oper. pressure	:	max. 64 bar
bolts/ nuts (section 6.6)	:	CS (max. 300°C) SS (-60 to +300 °C) Ck35/C35 (A194 Gr 2) ^x 21CrMoV57/ 24CrMo5 (A193 Gr B) ^x ^x max. 400°C)
gaskets (section 6.7)	:	Graphit cam profile up to 400 °C ^{***} Graphit spiral wounded up to 400 °C ^{***}
standard dim.	:	A= 172* B= 82** C= 60*** E= 12

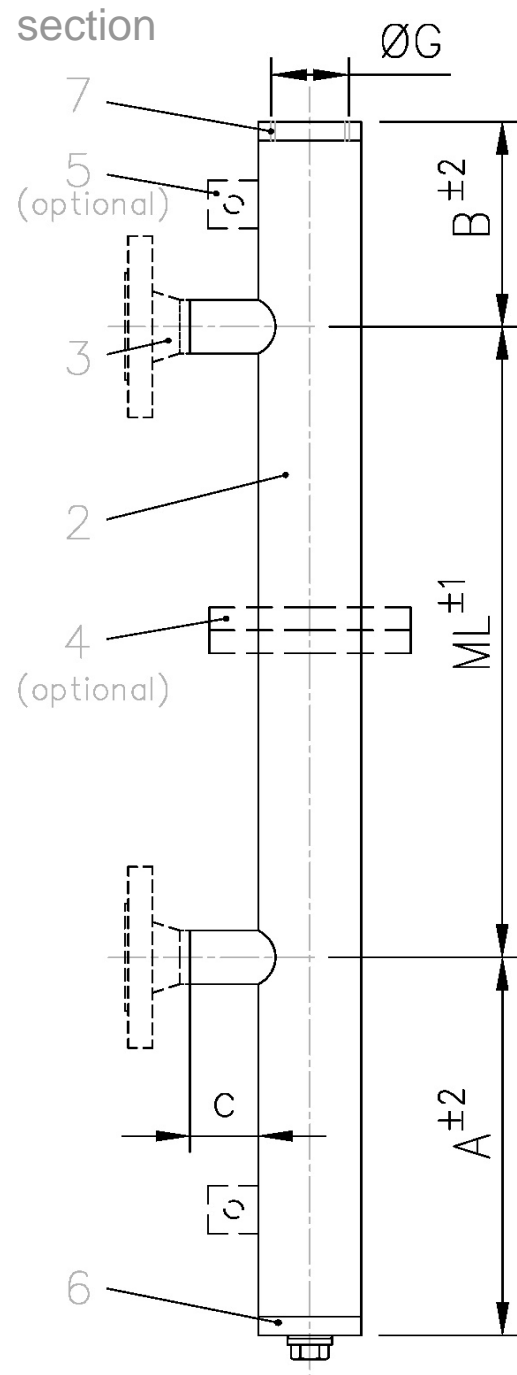

Base equipment printed bold!

* for flanged connection: A= 70 + height of flange

** for flanged connection: B= 160 + height of flange

*** only in combination with drain-flange ≥ DN50 or 2"; then C= 60 + height of flange

TDR-	1. Base type		pressure rating		
	7	vertical mounting	PN 64	300 lbs	
2. Reference vessel					
	material		vessel diam.	dimension	
S1	316Ti (1.4571)		DN50/ 2"	Ø60,3x2,9mm	
C0	CS (St 35.8)		DN50/ 2"	Ø60,3x2,9mm	
S6	316Ti (1.4571)		DN80/ 3"	Ø88,9x4mm	
C4	CS (St 35.8)		DN80/ 3"	Ø88,8x4mm	
Y2	other				
2.1 measuring length (please specify)			vessel diam.	material	
M01	center/ center process connection in mm (or inch)	DN50/ 2"	316Ti	
M09	center/ center process connection in mm (or inch)	DN50/ 2"	CS	
M06	center/ center process connection in mm (or inch)	DN80/ 3"	316Ti	
M13	center/ center process connection in mm (or inch)	DN80/ 3"	CS	
Y3	other				
3. Process connection (1 pair)					
1	side/ side				
Y4	other				
3.1 rule type					
D	in acc. to DIN				
A	in acc. to ANSI				
Y5	other				
3.2 connection type					
S	welding stud				
3.3 connection form					
	_____ please specify dimension & welding bevel				
N	nipple				
M	sleeve				
3.3 connection form					
	DIN				
G	thread form G				
	ANSI				
N	thread form NPT				
Y7	other				
3.4 connection size				material	
A01	1/2"			as vessel	
A11	3/4"			as vessel	
A21	1"			as vessel	
A31	1 1/4"			as vessel	
A41	1 1/2"			as vessel	
A51	2"			as vessel	
Y8	other			as vessel	
3.5 connection surface					
00	not defined				
F	flange			316Ti or CS	
Y6	other				
3.3 connection form					
V	welding neck flange				
L	lap joint flange				
Y7	other				
3.4 connection size					
	DIN		ANSI		material
	DN	PN	DN	lbs	
C03	DN15	PN64	1/2"	300	CS
C13	DN20	PN64	3/4"	300	CS
C23	DN25	PN64	1"	300	CS
C43	DN40	PN64	1 1/2"	300	CS
C53	DN50	PN64	2"	300	CS
C63	DN80	PN64	3"	300	CS
S03	DN15	PN64	1/2"	300	316Ti
S13	DN20	PN64	3/4"	300	316Ti
S33	DN32	PN64	1 1/4"	300	316Ti
S43	DN40	PN64	1 1/2"	300	316Ti
S53	DN50	PN64	2"	300	316Ti
S63	DN80	PN64	3"	300	316Ti
Y8	other				

3.5 connection surface							material
DIN							
C0	form C, DIN 2526						316Ti or CS
D0	form D, DIN 2526						316Ti or CS
E0	form E, DIN 2526						316Ti or CS
NC	form N, DIN 2526						CS
NS	form N, DIN 2526						316Ti
FC	form F, DIN 2526						CS
FS	form F, DIN 2526						316Ti
ANSI							material
RF	ANSI RF						316Ti or CS
SF	ANSI RF SF						316Ti or CS
JC	ANSI RTJ						CS
JS	ANSI RTJ						316Ti
Y9	other						
4. Flanged connection for measuring length>5000mm				vessel diam.	Werkstoff		
V00	without, for measuring length<5000mm				316Ti or CS		
V55	DN50 PN64			DN50/ 2"	CS		
V56	DN50 PN64			DN50/ 2"	316Ti		
V65	DN80 PN64			DN80/ 3"	CS		
V66	DN80 PN64			DN80/ 3"	316Ti		
Y10	other						
5. Support brackets		x= quantity (please specify)			Werkstoff		
H0	without						
HCx	support brackets (plate with 2 bore holes)						CS
HSx	support brackets (plate with 2 bore holes)						316Ti
6. Drain connection							
E	end cap with plug						
F	flange						
6.1 rule type							
D	in acc. to DIN						
A	in acc. to ANSI						
Y11	other						
6.2 drain type							material
0	for end cap						as vessel
6.3 connection form							
DIN							
G	thread form G						
ANSI							
N	thread form NPT						
Y7	other						
6.4 connection size							material
G01	1/2"						CS
G11	3/4"						
G21	1"						
G02	1/2"						316Ti
G12	3/4"						
G22	1"						
Y14	other						other
6.5							
0	not defined						
6.6							
0	not defined						
6.7							
0	not defined						
6.2 type with blindflange		DIN	PN	ANSI	lbs	vessel diam.	material
C41	blindflange	DN50	PN64	2"	300	DN50/ 2"	CS
C42	blindflange	DN50	PN64	2"	300	DN50/ 2"	316Ti
C43	welding neck flange	DN50	PN64	2"	300	DN50/ 2"	CS
C44	welding neck flange	DN50	PN64	2"	300	DN50/ 2"	316Ti
C51	blindflange	DN80	PN64	3"	300	DN80/ 3"	CS
C52	blindflange	DN80	PN64	3"	300	DN80/ 3"	316Ti
C53	welding neck flange	DN80	PN64	3"	300	DN80/ 3"	CS
C54	welding neck flange	DN80	PN64	3"	300	DN80/ 3"	316Ti
Y12	other						
6.3 form							material
DIN							
C0	form C, DIN 2526						316Ti or CS
D0	form D, DIN 2526						316Ti or CS
E0	form E, DIN 2526						316Ti or CS
NC	form N, DIN 2526						CS
NS	form N, DIN 2526						316Ti
FC	form F, DIN 2526						CS
FS	form F, DIN 2526						316Ti
DIN							
R0	ANSI RF						316Ti or CS
S0	ANSI RF SF						316Ti or CS
JC	ANSI RTJ						CS
JS	ANSI RTJ						316Ti
Y13	other						

6.4 drain plug	
0	without
P	plugged
Y14	other
6.5 thread type	
0	without plug
DIN	
G	thread form G
ANSI	
N	thread form NPT
Y15	other
6.6 plug size	
0	without plug
S01	1/2"
S11	3/4"
S21	1"
S01	1/2"
S11	3/4"
S21	1"
Y16	other
6.7 screw connection (DIN/ANSI)	
C01	bolts/nuts; mat. SS
C01	bolts/nuts; mat. CS
C11	bolts/nuts; mat. Ck35/C35 (A194 Gr 2)
C12	bolts/nuts; mat. 21CrMoV57/24CrMo5 (A193 Gr B)
Y17	other
6.8 gasket (DIN/ANSI)	
S	Graphit/ spiral wounded
K	Graphit/ cam profile
Y18	other

7. Instruments connection for measuring equipment	
E	end cap with thread
F	flange

7.1 rule type	
D	in acc. to DIN
A	in acc. to ANSI
Y19	other

7.2 type of instruments connection	
0	for end cap

7.3 form	
DIN	
G	thread form G
ANSI	
N	thread form NPT
Y20	other

7.4 connection size	
G1	3/4"
G3	1 1/2"
Y21	other

7.2 type		DIN	PN	ANSI	lbs	vessel diam.	material
L41	blindflange	DN50	PN64	2"	300	DN50/ 2"	CS
L42	blindflange	DN50	PN64	2"	300	DN50/ 2"	316Ti
L43	welding neck flange	DN50	PN64	2"	300	DN50/ 2"	CS
L44	welding neck flange	DN50	PN64	2"	300	DN50/ 2"	316Ti
L51	blindflange	DN80	PN64	3"	300	DN80/ 3"	CS
L52	blindflange	DN80	PN64	3"	300	DN80/ 3"	316Ti
L53	welding neck flange	DN80	PN64	3"	300	DN80/ 3"	CS
L54	welding neck flange	DN80	PN64	3"	300	DN80/ 3"	316Ti
Y22	other						

7.3 form	
DIN	
C0	form C, DIN 2526
D0	form D, DIN 2526
E0	form E, DIN 2526
NC	form N, DIN 2526
NS	form N, DIN 2526
FC	form F, DIN 2526
FS	form F, DIN 2526
ANSI	
R0	ANSI RF
S0	ANSI RF SF
JC	ANSI RTJ
JS	ANSI RTJ
Y23	other

Technical Information 2006	unit	Reference Vessel TDR-10 PN100	01.04.2006
	type		page 13
	series		

base equipment reference vessel type TDR-10

version	:	communicating vessel for built-in of measuring-systems
installation	:	vertical
measuring length (section 2.1)	:	max. 5000 mm (single-piece constr.) > 5000 mm (2- or multiparts) (section 4)
vessel diameter (section 2)	:	60,3 x 3,2 mm (1.4571/ 316Ti) 60,3 x 3,2 mm (St35.8/ A 106A) 88,8 x 4,5 mm (1.4571/ 316Ti) 88,8 x 6,3 mm (St35.8/ A 106A)
process connection (section 3)	:	optionally welding or threaded flange DN15 up to DN80 PN100 flange ½" up to 3" 600#
drain connection (section 6)	:	plug G½" (add. options s. section 6.2)
material of vessel (section 2)	:	1.4571 (316Ti) St35.8 (A 106A) other materials on request
flange material (section 3.4)	:	1.4571 (316Ti) St35.8 (A 106A) other materials on request
oper. temperature	:	-50 up to +400 °C (1.4571/ 316Ti) -10 up to +400 °C (St35.8/ A 106A)
oper. pressure	:	max. 100 bar
bolts/ nuts (section 6.6)	:	CS (max. 300°C) SS (-60 to +300 °C) Ck35/C35 (A194 Gr 2) ^x 21CrMoV57/ 24CrMo5 (A193 Gr B) ^x ^x max. 400°C)
gaskets (section 6.7)	:	Graphit cam profile up to 400 °C ^{***} Graphit spiral wounded up to 400 °C ^{***}
standard dim.	:	A= 172* B= 82** C= 60*** E= 12

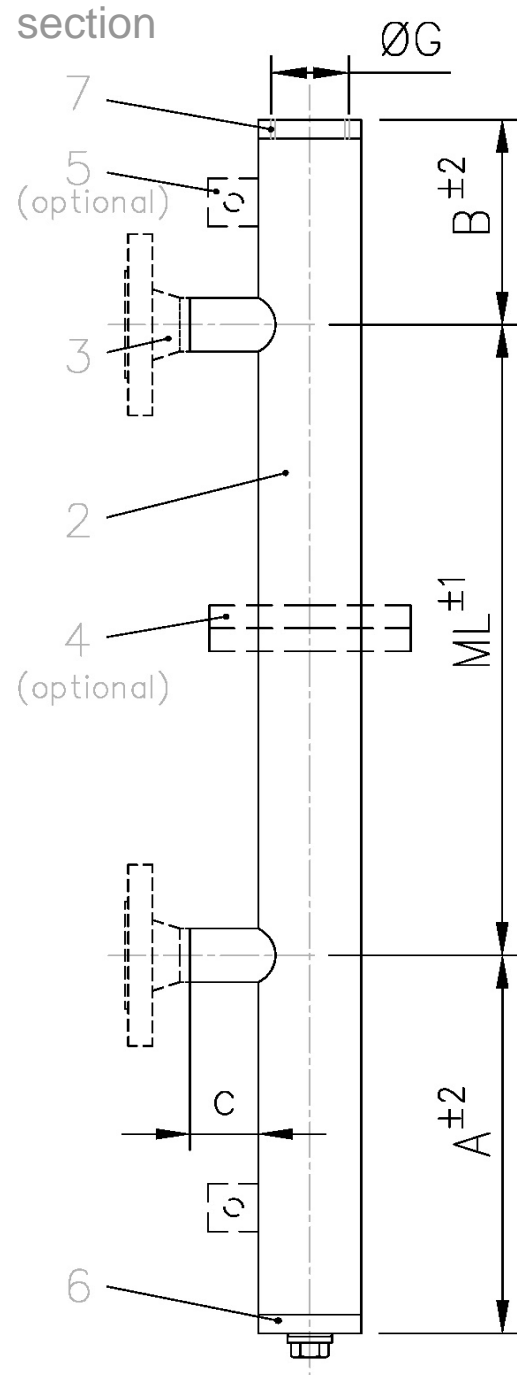

Base equipment printed bold!

* for flanged connection: A= 70 + height of flange

** for flanged connection: B= 160 + height of flange

*** only in combination with drain-flange >= DN50 or 2"; then C= 60 + height of flange

TDR-	1. Base type		<i>pressure rating</i>		
10	vertical mounting	PN 100	600 lbs		
2. Reference vessel					
	<i>material</i>		<i>vessel diam.</i>	<i>dimension</i>	
S2	316Ti (1.4571)		DN50/ 2"	Ø60,3x3,2mm	
C1	CS (St 35.8)		DN50/ 2"	Ø60,3x3,2mm	
S7	316Ti (1.4571)		DN80/ 3"	Ø88,8x4,5mm	
C5	CS (St 35.8)		DN80/ 3"	Ø88,8x6,3mm	
Y2	other				
2.1 measuring length (please specify)			<i>vessel diam.</i>	<i>material</i>	
M02	center/ center process connection in mm (or inch)		DN50/ 2"	316Ti	
M10	center/ center process connection in mm (or inch)		DN50/ 2"	CS	
M07	center/ center process connection in mm (or inch)		DN80/ 3"	316Ti	
M14	center/ center process connection in mm (or inch)		DN80/ 3"	CS	
Y3	other				
3. Process connection (1 pair)					
1	side/ side				
Y4	other				
3.1 rule type					
D	in acc. to DIN				
A	in acc. to ANSI				
Y5	other				
3.2 connection type					
S	welding stud				
3.3 connection form					
	_____ please specify dimension & welding bevel				
N	nipple				
M	sleeve				
3.3 connection form					
	<i>DIN</i>				
G	thread form G				
	<i>ANSI</i>				
N	thread form NPT				
Y7	other				
3.4 connection size				<i>material</i>	
A01	1/2"			as bypass	
A11	3/4"			as bypass	
A21	1"			as bypass	
A31	1 1/4"			as bypass	
A41	1 1/2"			as bypass	
A51	2"			as bypass	
Y8	other				
3.5 connection surface					
	00 not defined				
F	flange				
Y6	other				
3.3 connection form					
V	welding neck flange				
L	lap joint flange				
Y7	other				
3.4 connection size					
	<i>DIN</i>		<i>ANSI</i>		<i>material</i>
	<i>DN</i>	<i>PN</i>	<i>DN</i>	<i>lbs</i>	
C04	DN15	PN100	1/2"	600	CS
C14	DN20	PN100	3/4"	600	CS
C24	DN25	PN100	1"	600	CS
C44	DN40	PN100	1 1/2"	600	CS
C54	DN50	PN100	2"	600	CS
C64	DN80	PN100	3"	600	CS
S04	DN15	PN100	1/2"	600	316Ti
S14	DN20	PN100	3/4"	600	316Ti
S24	DN25	PN100	1"	600	316Ti
S44	DN40	PN100	1 1/2"	600	316Ti
S54	DN50	PN100	2"	600	316Ti
S64	DN80	PN100	3"	600	316Ti
Y8	other				

3.5 connection surface							material
DIN							
C0	form C, DIN 2526						316Ti or CS
D0	form D, DIN 2526						316Ti or CS
E0	form E, DIN 2526						316Ti or CS
NC	form N, DIN 2526						CS
NS	form N, DIN 2526						316Ti
FC	form F, DIN 2526						CS
FS	form F, DIN 2526						316Ti
ANSI							material
RF	ANSI RF						316Ti or CS
SF	ANSI RF SF						316Ti or CS
JC	ANSI RTJ						CS
JS	ANSI RTJ						316Ti
Y9	other						
4. Flanged connection for measuring length>5000mm		vessel diam.		material			
V00	without, for measuring length<5000mm			316Ti or CS			
V57	DN50 PN100	DN50/ 2"		CS			
V58	DN50 PN100	DN50/ 2"		316Ti			
V67	DN80 PN100	DN80/ 3"		CS			
V68	DN80 PN100	DN80/ 3"		316Ti			
Y10	other						
5. Support brackets		x= quantity (please specify)		material			
H0	without						
HCx	support brackets (plate with 2 bore holes)			CS			
HSx	support brackets (plate with 2 bore holes)			316Ti			
6. Drain connection							
E	end cap with plug						
F	flange						
6.1 rule type							
D	in acc. to DIN						
A	in acc. to ANSI						
Y11	other						
6.2 drain type							material
0	for end cap						as bypass
6.3 connection form							
DIN							
G	thread form G						
ANSI							
N	thread form NPT						
Y7	other						
6.4 connection size							material
G01	1/2"						CS
G11	3/4"						
G21	1"						
G02	1/2"						316Ti
G12	3/4"						
G22	1"						
Y14	other						other
6.5							
0	not defined						
6.6							
0	not defined						
6.7							
0	not defined						
6.2 type with blindflange		DIN	PN	ANSI	lbs	vessel diam.	material
D41	blindflange	DN50	PN100	2"	600	DN50/ 2"	CS
D42	blindflange	DN50	PN100	2"	600	DN50/ 2"	316Ti
D43	welding neck flange	DN50	PN100	2"	600	DN50/ 2"	CS
D44	welding neck flange	DN50	PN100	2"	600	DN50/ 2"	316Ti
D51	blindflange	DN80	PN100	3"	600	DN80/ 3"	CS
D52	blindflange	DN80	PN100	3"	600	DN80/ 3"	316Ti
D53	welding neck flange	DN80	PN100	3"	600	DN80/ 3"	CS
D54	welding neck flange	DN80	PN100	3"	600	DN80/ 3"	316Ti
Y12	other						
6.3 form							material
DIN							
C0	form C, DIN 2526						316Ti or CS
D0	form D, DIN 2526						316Ti or CS
E0	form E, DIN 2526						316Ti or CS
NC	form N, DIN 2526						CS
NS	form N, DIN 2526						316Ti
FC	form F, DIN 2526						CS
FS	form F, DIN 2526						316Ti
DIN							
R0	ANSI RF						316Ti or CS
S0	ANSI RF SF						316Ti or CS
JC	ANSI RTJ						CS
JS	ANSI RTJ						316Ti
Y13	other						

6.4 drain plug	
0	without
P	plugged
Y14	other
6.5 thread type	
0	without plug
DIN	
G	thread form G (max. 78 bar @ 400 °C)
ANSI	
N	thread form NPT
Y15	other
6.6 plug size	
0	without plug
S01	1/2"
S11	3/4"
S21	1"
S01	1/2"
S11	3/4"
S21	1"
Y16	andere
6.7 screw connection (DIN/ANSI)	
C01	bolts/nuts; mat. SS
C01	bolts/nuts; mat. CS
C11	bolts/nuts; mat. Ck35/C35 (A194 Gr 2)
C12	bolts/nuts; mat. 21CrMoV57/24CrMo5 (A193 Gr B)
Y17	other
6.8 gasket (DIN/ANSI)	
S	Graphit/ spiral wounded
K	Graphit/ cam profile
Y18	other

7. Instruments connection for measuring equipment

E	end cap with thread
F	flange
7.1 rule type	
D	in acc. to DIN
A	in acc. to ANSI
Y19	other

7.2 type of instruments connection	
0	for end cap
material	
	as bypass

7.3 form	
DIN	
G	thread form G (max. 78 bar @ 400 °C)
ANSI	
N	thread form NPT
Y20	other

7.4 connection size	
G1	3/4"
G3	1 1/2"
Y21	other
material	
	as bypass
	as bypass

7.2 type	DIN	PN	ANSI	lbs	vessel diam.	material
M41	blindflange	DN50	PN100	2"	600	DN50/ 2"
M42	blindflange	DN50	PN100	2"	600	DN50/ 2"
M43	welding neck flange	DN50	PN100	2"	600	DN50/ 2"
M44	welding neck flange	DN50	PN100	2"	600	DN50/ 2"
M51	blindflange	DN80	PN100	3"	600	DN80/ 3"
M52	blindflange	DN80	PN100	3"	600	DN80/ 3"
M53	welding neck flange	DN80	PN100	3"	600	DN80/ 3"
M54	welding neck flange	DN80	PN100	3"	600	DN80/ 3"

7.3 form	
DIN	
C0	form C, DIN 2526
D0	form D, DIN 2526
E0	form E, DIN 2526
NC	form N, DIN 2526
NS	form N, DIN 2526
FC	form F, DIN 2526
FS	form F, DIN 2526
ANSI	
R0	ANSI RF
S0	ANSI RF SF
JC	ANSI RTJ
JS	ANSI RTJ
Y23	other
material	
	316Ti or CS
	316Ti or CS
	CS
	316Ti

Technical Information 2006	unit	Reference Vessel TDR-11 PN160	01.04.2006
	type		page 17
	series		

base equipment reference vessel type TDR-11

version	:	communicating vessel for built-in of measuring-systems
installation	:	vertical
measuring length (section 2.1)	:	max. 5000 mm (single-piece constr.) > 5000 mm (2- or multiparts) (section 4)
vessel diameter (section 2)	:	60,3 x 5,4 mm (1.4571/ 316Ti) 60,3 x 6,3 mm (St35.8/ A 106A) 88,9 x 7,62 mm (1.4571/ 316Ti) 88,9 x 8,0 mm (St35.8/ A 106A)
process connection (section 3)	:	optionally welding or threaded stud flange DN15 up to DN80 PN160 flange ½" up to 3" 1500#
drain connection (section 6)	:	plug G½" (add. options s. section 6.2)
material of vessel (section 2)	:	1.4571 (316Ti) St35.8 (A 106A) other materials on request
flange material (section 3.4)	:	1.4571 (316Ti) St35.8 (A 106A) other materials on request
oper. temperature	:	-50 up to +400 °C (1.4571/ 316Ti) -10 up to +400 °C (St35.8/ A 106A)
oper. pressure	:	max. 40 bar
bolts/ nuts (section 6.6)	:	CS (max. 300°C) SS (-60 to +300 °C) Ck35/C35 (A194 Gr 2) ^x 21CrMoV57/ 24CrMo5 (A193 Gr B) ^x ^x max. 400°C)
gaskets (section 6.7)	:	Graphit cam profile up to 400 °C ^{***} Graphit spiral wounded up to 400 °C ^{***}
standard dim.	:	A= 172* B= 82** C= 60*** E= 12

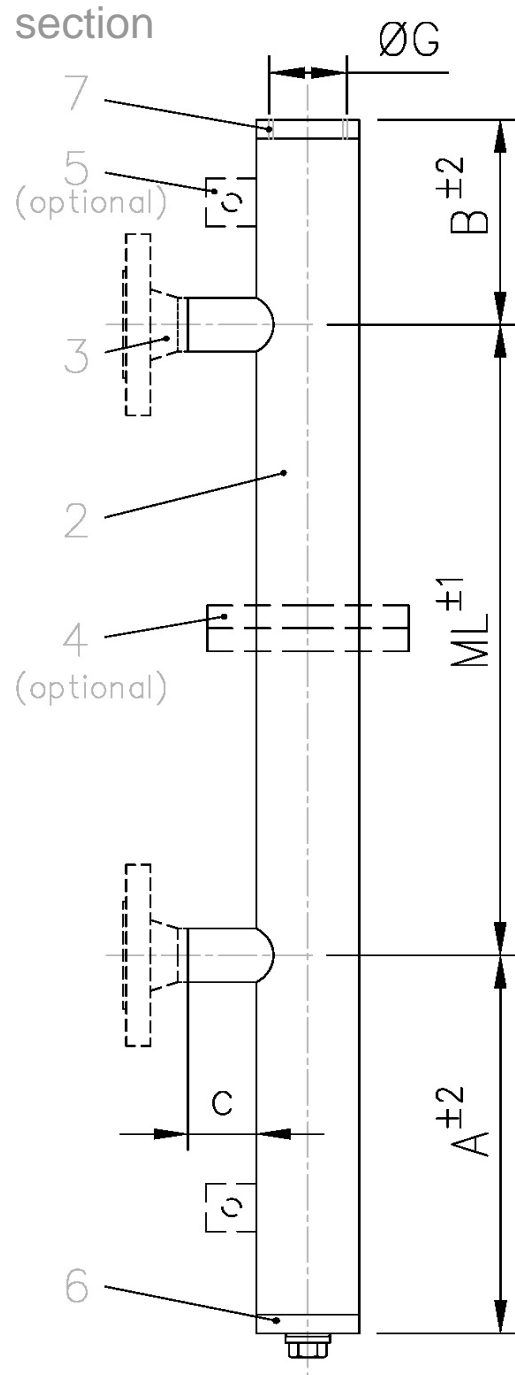

Base equipment printed bold!

* for flanged connection: A= 70 + height of flange

** for flanged connection: B= 160 + height of flange

*** only in combination with drain-flange ≥ DN50 or 2"; then C= 60 + height of flange

TDR-	1. Base type	<i>pressure rating</i>	
	11 vertical mounting	PN 160	1500 lbs
	2. Reference vessel		
	<i>material</i>	<i>vessel diam.</i>	<i>dimension</i>
	S3 316Ti (1.4571)	DN50/ 2"	Ø60,3x5,54mm
	C2 CS (St 35.8)	DN50/ 2"	Ø60,3x6,3mm
	S8 316Ti (1.4571)	DN80/ 3"	Ø88,9x7,62mm
	C6 CS (St 35.8)	DN80/ 3"	Ø88,9x8,0mm
	Y2 other		
	2.1 measuring length (please specify)		<i>vessel diam.</i>
	M03	center/ center process connection in mm (or inch)	DN50/ 2"
	M11	center/ center process connection in mm (or inch)	DN50/ 2"
	M08	center/ center process connection in mm (or inch)	DN80/ 3"
	M15	center/ center process connection in mm (or inch)	DN80/ 3"
	Y3	other	
	3. Process connection (1 pair)		
	1	side/ side	
	Y4	other	
	3.1 rule type		
	D	in acc. to DIN	
	A	in acc. to ANSI	
	Y5	other	
	3.2 connection type		
	S	welding stud	
	3.3 connection form		
		<i>please specify dimension & welding bevel</i>	
	N	nipple	
	M	sleeve	
	3.3 connection form		
		<i>DIN</i>	
	G	thread form G (max. 78 bar @ 400 °C; max. 160 bar @ 110 °C)	
		<i>ANSI</i>	
	N	thread form NPT	
	Y7	other	
	3.4 connection size		<i>material</i>
	A01	1/2"	as bypass
	A11	3/4"	as bypass
	A21	1"	as bypass
	A31	1 1/4"	as bypass
	A41	1 1/2"	as bypass
	A51	2"	as bypass
	Y8	other	as bypass
	3.5 connection surface		
	00	not defined	
	F	flange	316Ti or CS
	Y6	other	
	3.3 connection form		
	V	welding neck flange	
	L	lap joint flange	
	Y7	other	
	3.4 connection size		
		<i>DIN</i>	<i>ANSI</i>
		<i>DN</i>	<i>DN</i>
		<i>PN</i>	<i>lbs</i>
			<i>material</i>
	C05	DN15 PN160	1/2" 1500
	C15	DN20 PN160	3/4" 1500
	C25	DN25 PN160	1" 1500
	C45	DN40 PN160	1 1/2" 1500
	C55	DN50 PN160	2" 1500
	C65	DN80 PN160	3" 1500
	S05	DN15 PN160	1/2" 1500
	S15	DN20 PN160	3/4" 1500
	S25	DN25 PN160	1" 1500
	S45	DN40 PN160	1 1/2" 1500
	S55	DN50 PN160	2" 1500
	S65	DN80 PN160	3" 1500
	Y8	other	

3.5 connection surface		material
<i>DIN</i>		
C0	form C, DIN 2526	316Ti or CS
D0	form D, DIN 2526	316Ti or CS
E0	form E, DIN 2526	316Ti or CS
NC	form N, DIN 2526	CS
NS	form N, DIN 2526	316Ti
FC	form F, DIN 2526	CS
FS	form F, DIN 2526	316Ti
<i>ANSI</i>		
RF	ANSI RF	316Ti or CS
SF	ANSI RF SF	316Ti or CS
JC	ANSI RTJ	CS
JS	ANSI RTJ	317Ti
Y9	other	

4. Flanged connection for measuring length>5000mm		vessel diam.	material
V00	without, for measuring length<5000mm		316Ti or CS
V59	DN50 PN160	DN50/ 2"	CS
V50	DN50 PN160	DN50/ 2"	316Ti
V69	DN80 PN160	DN80/ 3"	CS
V60	DN80 PN160	DN80/ 3"	316Ti
Y10	other		

5. Support brackets		x= quantity (please specify)	material
H0	without		
HCx	support brackets (plate with 2 bore holes)		CS
HSx	support brackets (plate with 2 bore holes)		316Ti

6. Drain connection	
E	end cap with plug
F	flange

6.1 rule type	
D	in acc. to DIN
A	in acc. to ANSI
Y11	other

6.2 drain type		material
0	for end cap	as bypass

6.3 connection form	
<i>DIN</i>	
G	thread form G (max. 78 bar @ 400 °C; max. 160 bar @ 110 °C)
<i>ANSI</i>	
N	thread form NPT
Y7	other

6.4 connection size		material
G01	1/2"	CS
G11	3/4"	
G21	1"	
G02	1/2"	316Ti
G12	3/4"	
G22	1"	
Y14	other	other

6.5	
0	not defined

6.6	
0	not defined

6.7	
0	not defined

6.2 type with blindflange	DIN	PN	ANSI	lbs	vessel diam.	material	
E41	blindflange	DN50	PN160	2"	1500	DN50/ 2"	CS
E42	blindflange	DN50	PN160	2"	1500	DN50/ 2"	316Ti
E43	welding neck flange	DN50	PN160	2"	1500	DN50/ 2"	CS
E44	welding neck flange	DN50	PN160	2"	1500	DN50/ 2"	316Ti
E51	blindflange	DN80	PN160	3"	1500	DN80/ 3"	CS
E52	blindflange	DN80	PN160	3"	1500	DN80/ 3"	316Ti
E53	welding neck flange	DN80	PN160	3"	1500	DN80/ 3"	CS
E54	welding neck flange	DN80	PN160	3"	1500	DN80/ 3"	316Ti
Y12	other						

6.3 form		material
<i>DIN</i>		
C0	form C, DIN 2526	316Ti or CS
D0	form D, DIN 2526	316Ti or CS
E0	form E, DIN 2526	316Ti or CS
NC	form N, DIN 2526	CS
NS	form N, DIN 2526	316Ti
FC	form F, DIN 2526	CS
FS	form F, DIN 2526	316Ti
<i>DIN</i>		
R0	ANSI RF	316Ti or CS
S0	ANSI RF SF	316Ti or CS
JC	ANSI RTJ	CS
JS	ANSI RTJ	316Ti
Y13	other	

6.4 drain plug	
0	without
P	plugged
Y14	other
6.5 thread type	
0	without plug
DIN	
G	thread form G (max. 78 bar @ 400 °C; max. 160 bar @ 110 °C)
ANSI	
N	thread form NPT
Y15	other
6.6 plug size	
0	without plug
S01	1/2"
S11	3/4"
S21	1"
S01	1/2"
S11	3/4"
S21	1"
Y16	other
6.7 screw connection (DIN/ANSI)	
C01	bolts/nuts; mat. SS
C01	bolts/nuts; mat. CS
C11	bolts/nuts; mat. Ck35/C35 (A194 Gr 2)
C12	bolts/nuts; mat. 21CrMoV57/24CrMo5 (A193 Gr B)
Y17	other
6.8 gasket (DIN/ANSI)	
S	Graphit/ spiral wounded
K	Graphit/ cam profile
Y18	other

7. Instruments connection for measuring equipment	
E	end cap with thread
F	flange

7.1 rule type	
D	in acc. to DIN
A	in acc. to ANSI
Y19	other

7.2 type of instruments connection	
0	for end cap
material	
	as bypass

7.3 form	
DIN	
G	thread form G (max. 78 bar @ 400 °C; max. 160 bar @ 110 °C)
ANSI	
N	thread form NPT
Y20	other

7.4 connection size	
G1	3/4"
G3	1 1/2"
Y21	other

7.2 type		DIN	PN	ANSI	lbs	vessel diam.	material
N41	blindflange	DN50	PN160	2"	1500	DN50/ 2"	CS
N42	blindflange	DN50	PN160	2"	1500	DN50/ 2"	316Ti
N43	welding neck flange	DN50	PN160	2"	1500	DN50/ 2"	CS
N44	welding neck flange	DN50	PN160	2"	1500	DN50/ 2"	316Ti
N51	blindflange	DN80	PN160	3"	1500	DN80/ 3"	CS
N52	blindflange	DN80	PN160	3"	1500	DN80/ 3"	316Ti
N53	welding neck flange	DN80	PN160	3"	1500	DN80/ 3"	CS
N54	welding neck flange	DN80	PN160	3"	1500	DN80/ 3"	316Ti
Y22	other						

7.3 form	
DIN	
C0	form C, DIN 2526
D0	form D, DIN 2526
E0	form E, DIN 2526
NC	form N, DIN 2526
NS	form N, DIN 2526
FC	form F, DIN 2526
FS	form F, DIN 2526
ANSI	
R0	ANSI RF
S0	ANSI RF SF
JC	ANSI RTJ
JS	ANSI RTJ
Y23	other