

4.7 Digital indication with volume linearization

Electrical level measurement transducers which use the displacement principle must be recalibrated each time the fluid density is changed.

The price of a magnetically controlled level indicator with integral electrical measurement transducer is considerably lower than level measurement transducers.

The reed chain with an R/I-measurement transducer can be changed without interrupting operation. The measurement chamber is hermetically sealed – there is no contact between the fluid chamber and the reed chain.

With the microprocessor-controlled level indicator unit type 420, the level can be displayed directly in any arbitrary physical measurement unit. The indicator has a curve calculator with which non-linear tank contents can be displayed directly in cubic meters.

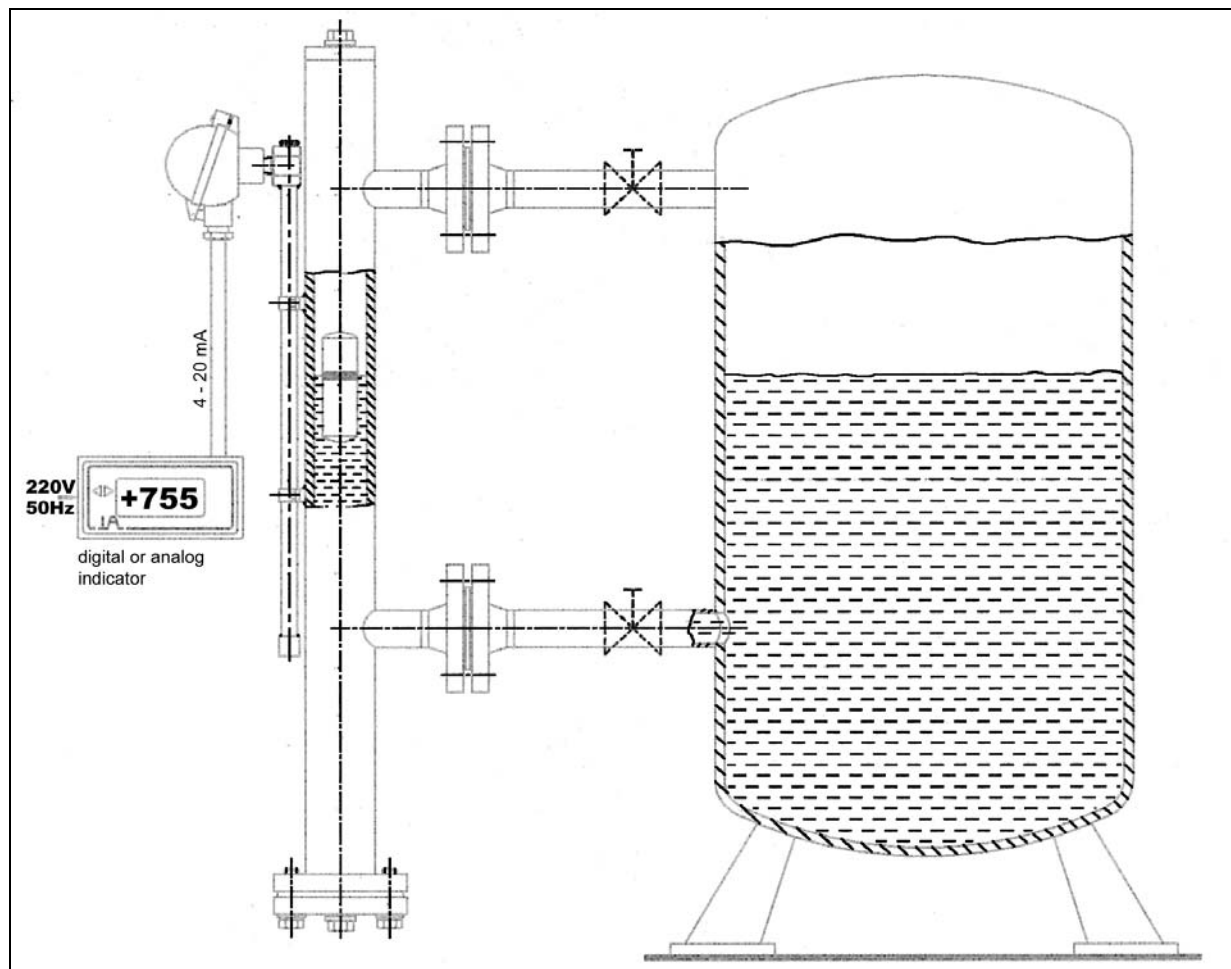

4.8 Niveau-source

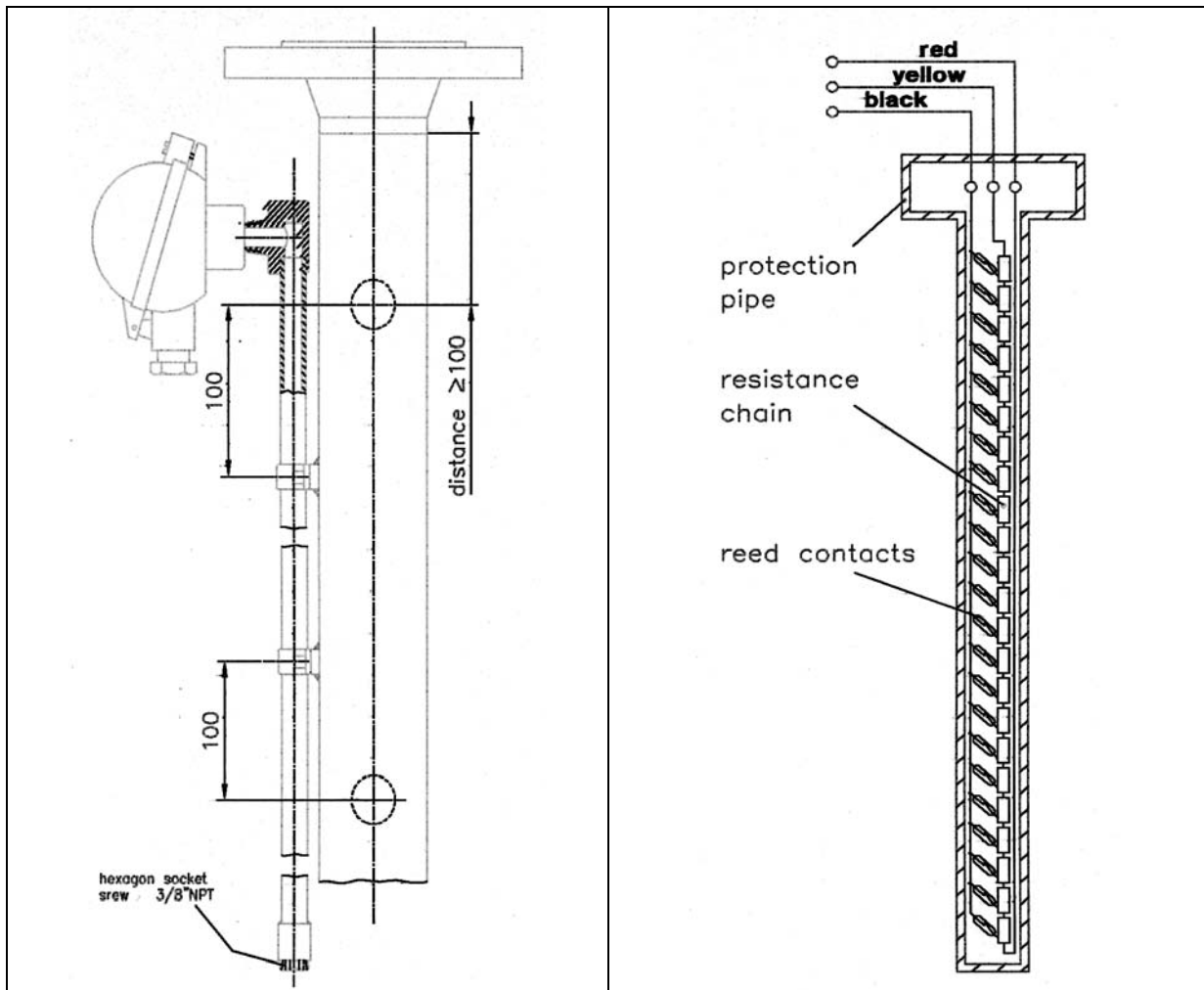

Measuring principle:

The resistance chain with the reed contacts are built in a pipe made of material 316SS. This so-called "Reed-chain" is mounted on the float chamber with tube clamps. According to the movement of the float, the float magnet closes one reed contact which produces a voltage (or resistance) proportional to the height of the liquid in the tank. You get a near-analogous output signal, with a resolution of about 10 mm.

The resistance chain receives its power supply from the transmitter. The 4...20 mA transmitter output signal can be transferred to an indicator or can be used to drive alarm contacts. In the case of an error the output signal becomes higher than 22 mA.

Connection:

As a standard, the reed chain is supplied with a transmitter that is installed inside the housing-head, 2-wire connection to the transmitter is only required.

4.9 Reed-contact

Standard reed chain

Max. medium temperature: 150 °C
 Protection pipe: Ø14 mm
 Material: 316Ti
 Enclosure: IP65

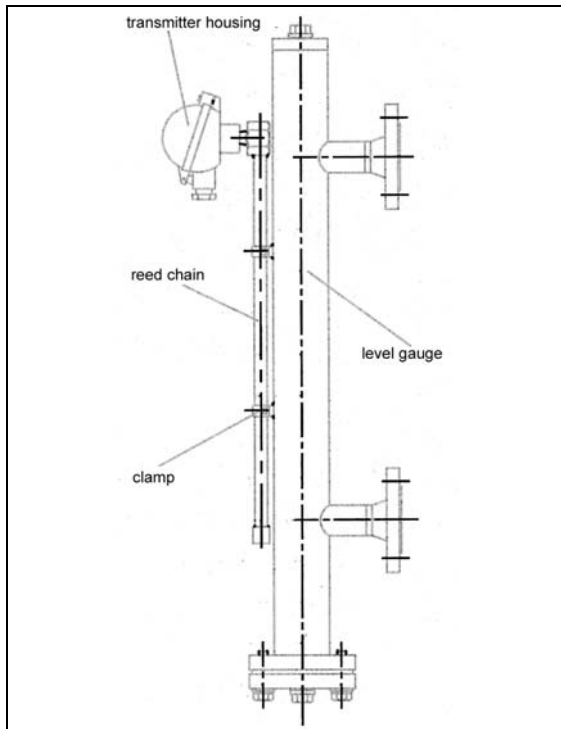

Reed chain for higher temperature

Max. medium temperature: 400 °C
 Protection pipe: Ø14 mm
 Material: 316Ti
 Enclosure: IP65
 Heat protection: 50x4 mm

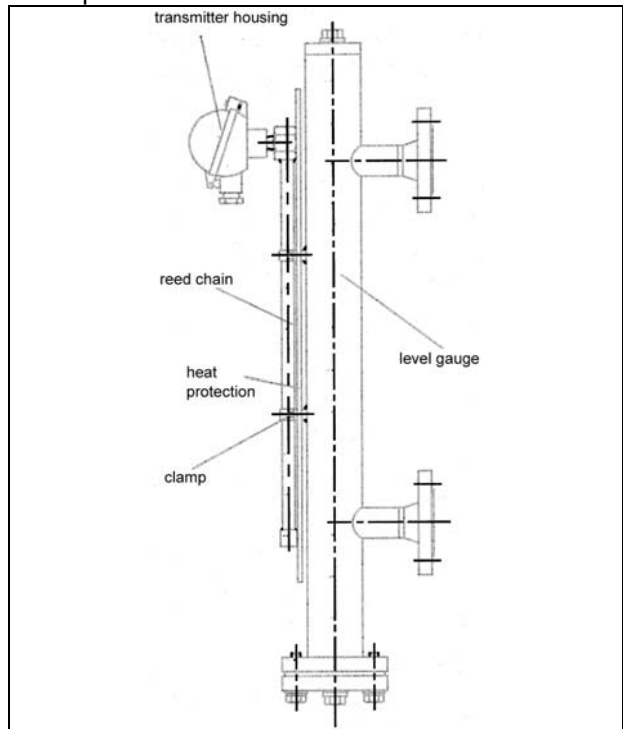

Clamp standard

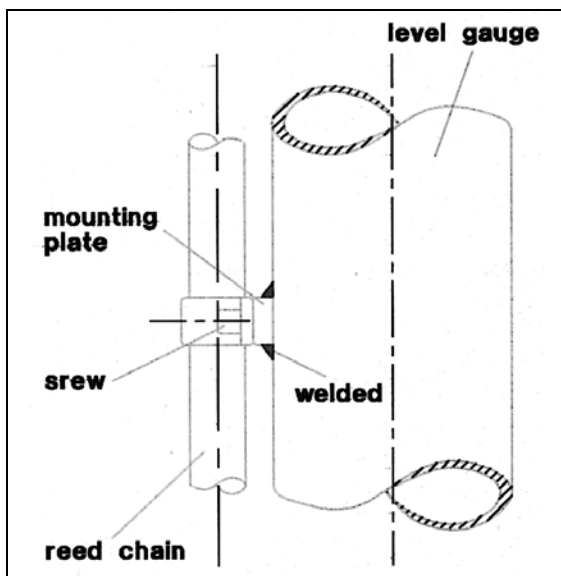

Clamp special

Will be needed by Armaflex isolation and secondary mounting off a reed chain.

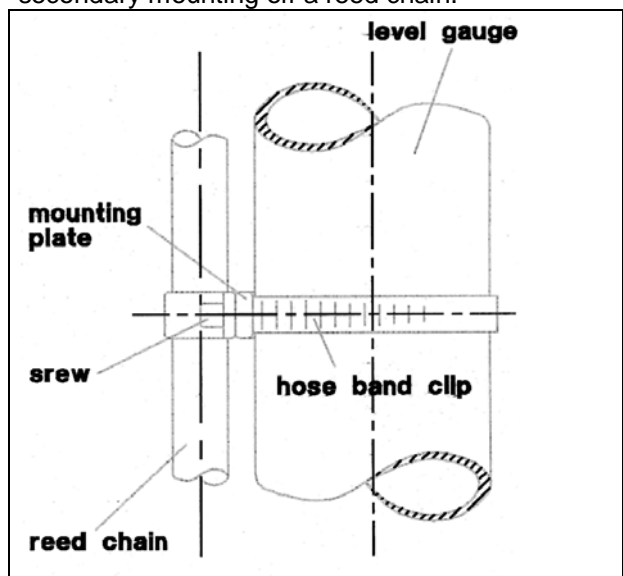

4.10 Magnetostrictive level transmitter

Datasheet M-300, M-400

Description:

Magnetostrictive transmitter for mounting to a level gauge type ITA

M-300/M-400 series working on the magnetostrictive principle is high accuracy transmitter for affordable price. The float inside of the level gauge type ITA containing a magnet moves along the magnetostrictive wire. A pulse generated by the electronics travels along the wire. When the pulse reaches the float's magnetic field, a twist develops in the wire. Reflected from the torsion point, the pulse creates an acoustic wave that travels back along the wire. The 4...20 mA output from the transmitter is proportional to the level.

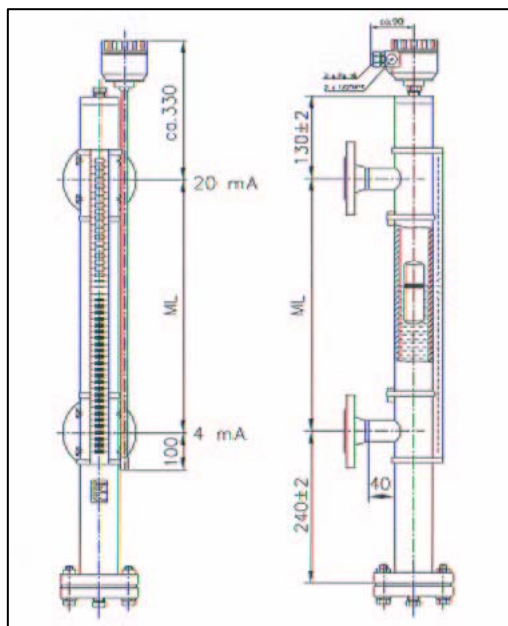

Technical data:

Type	rigid version	flexible version
principle/design:	magnetostrictive 2-wire transmitter	
measured process values:	level, interface level	
sensor length:	0,5...3 m	3...10 m
materials	Stainless steel (1.4571 – DIN)	
sensor:	Aluminium, powder paint coated or plastic (PBT)	
housing:	depends on the level gauge type ITA	
max. pressure:	Max. +150°C (+400°C for high-temperature-version)	
Temperature	-25°C...+70°C*	
Medium:		
Ambient:		
linearity with dry calibration:	±1 mm	
resolution:	1 mm or 5 mm (depends on order)	
temperature coefficient:	0,04 mm/°C	
measuring range:	min. 200 mm	
medium density:	depends on the level gauge type ITA	
outputs	4...20 mA or 20...4 mA	
analogue:	Hart	
serial:	6 digits (7 mm characters) icon; bargraph	
display:	0...60 s programmable	
damping:	3,8 mA or 22 mA	
error indication:	Rt=(Us-12V)/0,02 A; Us= voltage of power supply	
output load:	12...36 V DC	
power supply:	Ex II 1 G EEx ia IIB T6 (0,5...5 m)	
ATEX approval:	Ex II 1 G EEx ia IIA T6 (3...10 m)	
intrinsically safe area:	U _{max} =30 V; I _{max} =80 mA; P _{max} =0,8 W; C _i <30 nF; L _i <200 µH	
protection	class III	
electric:	IP67	
ingress:	cable gland PG16 or M20x1,5	
electrical connection:	cable diameter: Ø8...Ø15 mm; wire cross section: max. 1,5 mm ²	
weight:	1,7kg + sensor (sensor = 0,6 kg/m)	1,7kg + sensor (sensor = 0,6 kg/m+12 kg)

* temperature classification for Ex-application

Temperature classification for Ex-Application

temperature class	ambient temperature	process temperature
T6	-25...+70 °C	Max. 400 °C, because no wetted parts
T5	-25...+59 °C	
T4	-25...+45 °C	

Order specification:

M	Magnetostrictive Level Transmitter		
	Function		/sensor design (depends on tube length)
T	with transmitter	/rigid sensor (0,5...3 m); flexible (> 3 m)	
B	with transmitter and display	/rigid sensor (0,5...3 m); flexible (> 3 m)	
	Connection to level gauge type ITA®		
U	Direct welded clamps; st. st.		
UX	Hose band clips; st.st.		
-			
	material electronic housing		
3	Aluminium/powder paint coated		
4	Plastic (PTB fiber-glass reinforced, flame retardant)		
	Measuring length		
ML	measuring length in mm		
-			
	Output	/resolution	/approval
2	4...20 mA	/1 mm	
4	4...20 mA; Hart	/1 mm	
6	4...20 mA	/1 mm	/Ex
8	4...20 mA; Hart	/1 mm	/Ex
A	4...20 mA	/5 mm	
E	4...20 mA; Hart	/5 mm	/Ex

M			-			-	
----------	--	--	---	--	--	---	--