

11.0 Series IBFD-HT for Superheated Steam to 5880 psi and 2210°F

Description

With its strengthened sensor head and assembly parts sensor type IBFD-HT is especially designed for use in superheated steam applications with high operating pressures and temperatures.

Materials	Max. Steam Temperature
1.5415 (15 Mo 3)	986 °F
1.7335 (10 CrMo 4 4)	1022 °F
1.7380 (10 CrMo 9 10)	1058°F
1.4903 (10 CrMoVNB 91)	1202°F

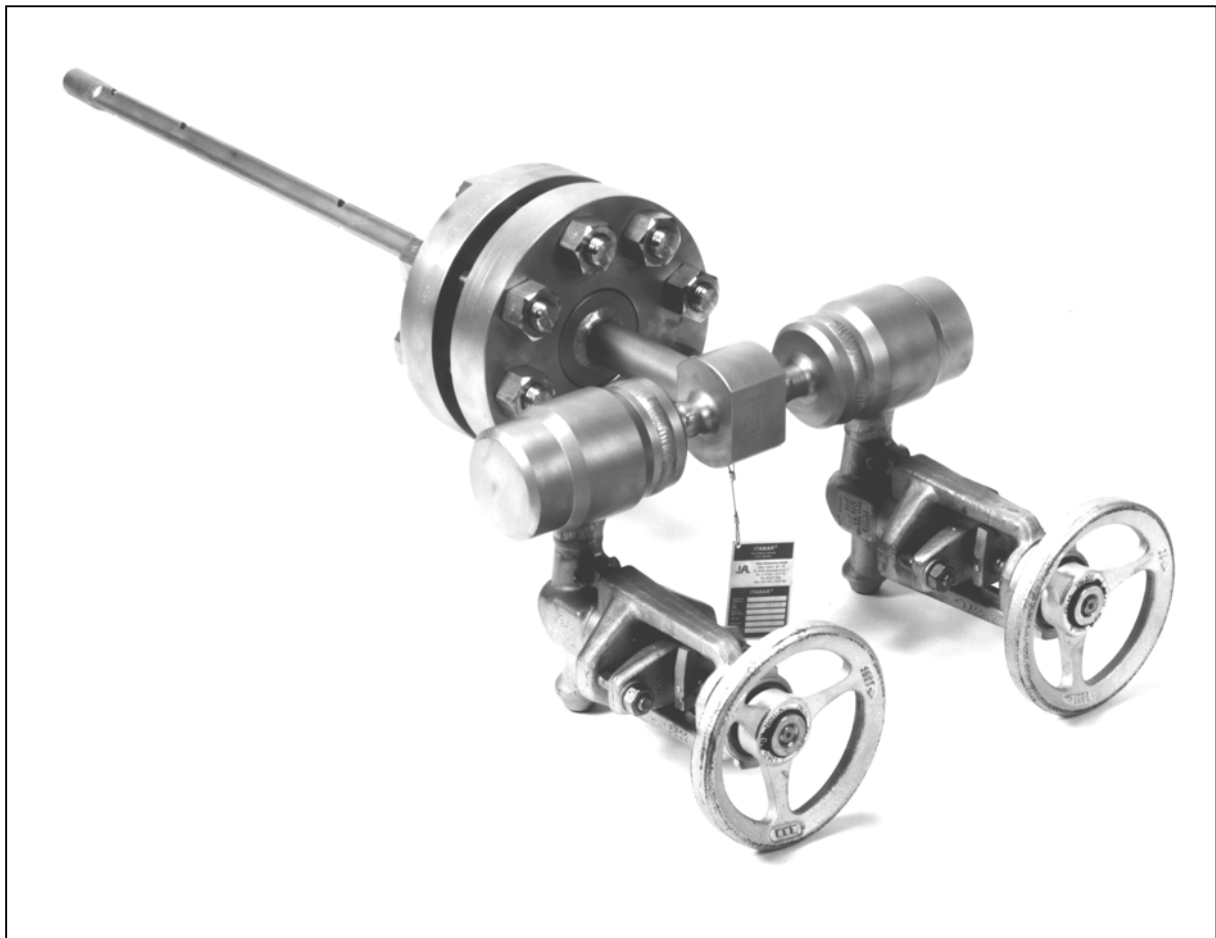

Drawing for ITABAR Series IBFD-HT

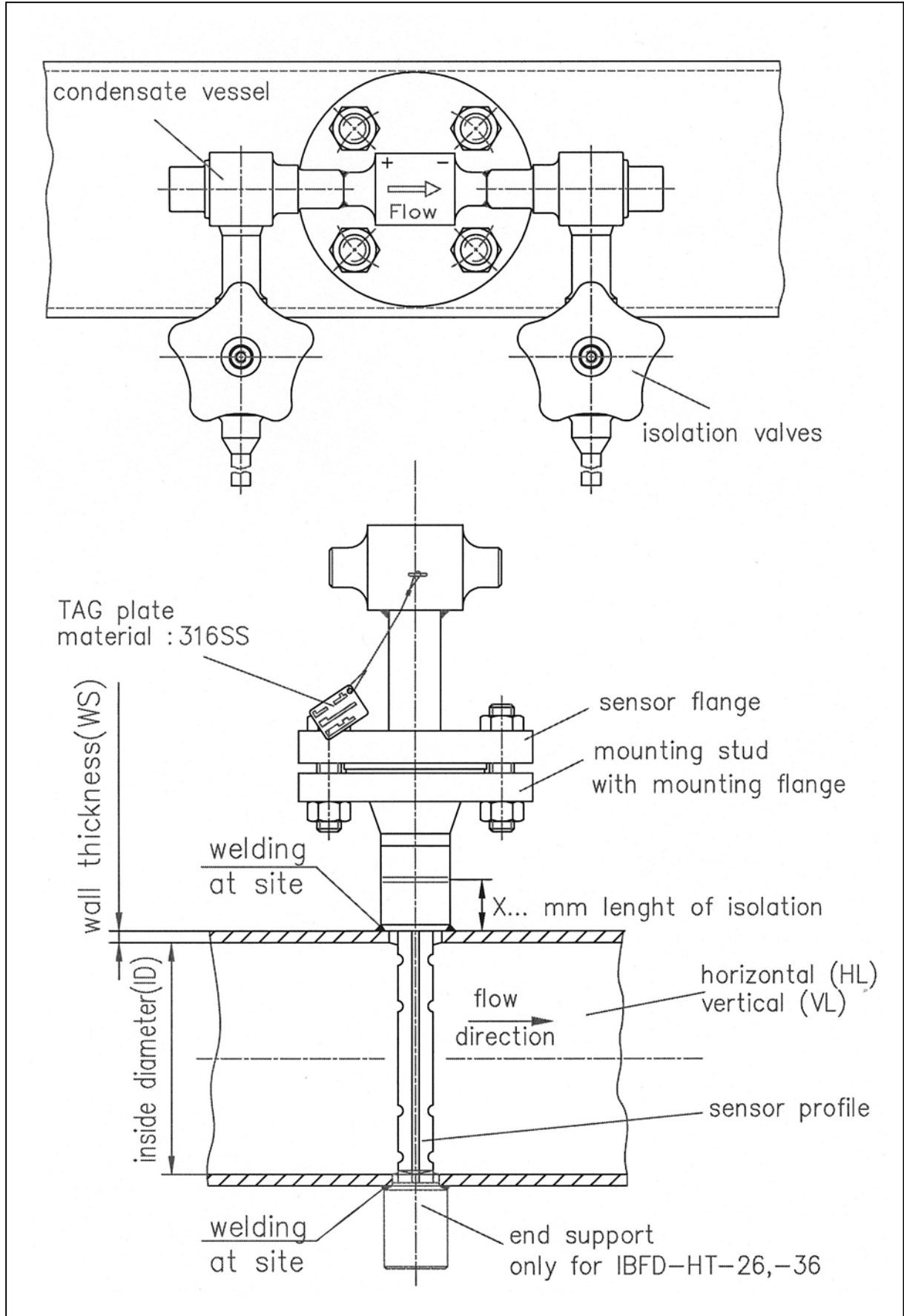

Order Data for ITABAR Series IBFD-HT

1. Sensor Type

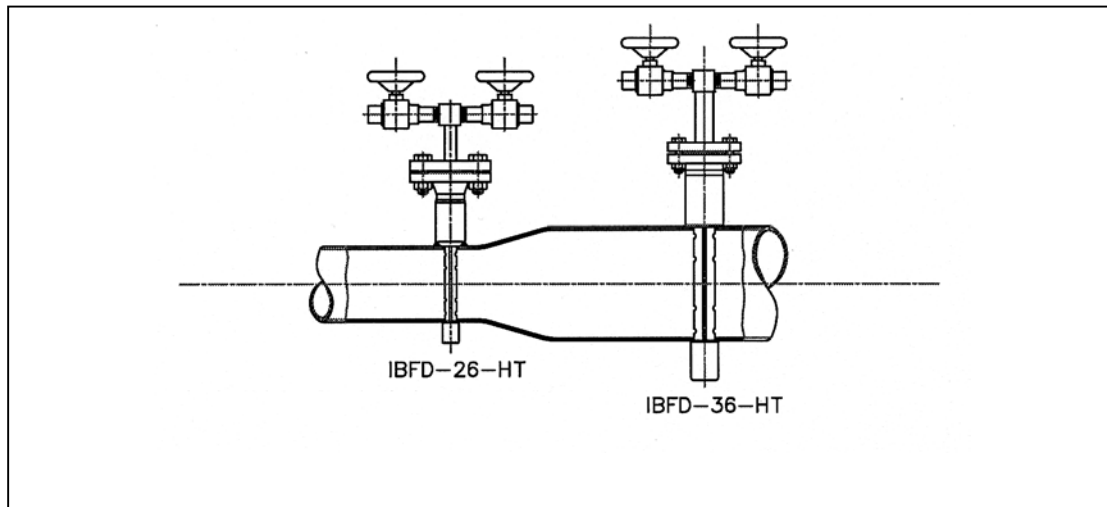

Pipe ID Inches	Maximal zulässiger Volumendurchfluss GPM	
	IBFD -26-HT	IBFD -36-HT
4	4857	---
5	6415	---
6	7972	---
8	11083	---
10	14476	---
12	18145	19826
14	21696	23786
16	25137	27755
20	32340	35323
24	39419	42803

These values are for water of 0.999 SGU and at a temperature T = 68 °F. To calculate volumetric or mass flow of fluids with other densities see chapter 6 „Specifications of DP Sensors with WINFLOW“.

Selection and Specification of a Steam- flow-Sensor
P-max. 5880 PSI (400 bar), P-T-max. 1202 °F

Order Example for ITABAR Flow Sensor, HT-Version

Existing Process Data

Pipe size	12"
Medium	Steam
Pressure	3822 PSI (260 bar)
Temperature	1184°F (640°C)
Material of existing pipe	10 CrMo 910

1. Determine the material of the pipe (to determine welding compatibility), in this example 10 CrMo 910.
2. From table , page 151, determine pressure specs of assembly welding boss.
3. From table, 135 determine compatible material – 10 CrMoVNb 91
4. With Winflow program determine the right sensor type (considering flow velocity). In this case the recommended sensor is IBFD-26-HT.
5. Selection of condensate pots and shut-off valves, see table page 153/154. If a combination condensate pots / shut-off valves is required see table 155. For the case of this example the table does not offer a combination. Thus condensate pots and shut-off valves must be ordered seperately.
6. Isolation of pipe – in this example 200 mm
7. Pipe configuration – in this example vertical

Oder code example

IBFD-26-HT-ID300/14mm-C-SM-1-D8-W-M-S37-C-K8-A22-A22-X200-VL

INTRA-AUTOMATION GmbH

D-41515 Grevenbroich * Otto-Hahn-Str. 20 * Tel: +49 2181-68761 * Fax: +49 2181-64492

WINFLOW 2.75 (I) Diff. Pressure Calculation ITABAR - Flow - Sensor

Company: Mustermann
 Name(capital letters):
 Street:
 Zip Code/City:
 Offer-/Com. No:
 P. Order Number:
 Tag No.:
 Serial No.:
 Pipe Data: ID= 300,000/15,000 mm - horizontal
 Date: 18.04.2002
 Person in charge U.P.

Calculation: Mass rate Gas & steam
 Fluid: Superheated steam

Pipe Internal Dimensions: 300,000 mm
 Flowing Temperature: 640,000 °C
 Flowing Pressure: 260,000 bar A
 Density: 68,669 kg/m³
 Viscosity: 0,0359 cPs
 K-Factor: 0,6274 without unit

Base Temperature	273,15 Kelvin
Base Pressure	101,30 kPa

	QMax	QNorm	QMin	
Flow Rate	50.000,00	40.000,00	10.000,00	kg/H
Reynolds No.	1.637.037	1.309.630	327.407	without unit
Permanent press. loss	6,290	4,020	0,250	mbar
Expansionsfactor	1,000	1,000	1,000	without unit
Velocity:	2,86	2,29	0,57	m/sec.
Differential Pressure	6,913	4,424	0,277	mbar

Itabar-Type: IBFD-26 HT-C-SM-1-D6-W-M-S37-C-K8-A22-A22-X200-VL
 Material Sensor: A335 GRADE P11 (10CrMoVNb 91)
 Note:

Max. DeltaP 1.905,20 mbar Max. Flow Rate 830.064,63 kg/H
 Natural Freq.: 121,16

1. Order specification ITABAR-FLOW-Sensor, series IBFD-26-HT

1. type of sensor				
26-HT	IBFD-26-HT			
2. inside diameter and wall thickness.				
ID / W.-thickn.	inside diameter and wall thickness in inches (or mm), please specify			
3. sensor material		max. op. temperature		
P	1.5415 (15 Mo 3)	530°C		
V	1.7335 (13 CrMo 4 4)	550°C		
R	1.7380 (10 CrMo 9 10)	570°C		
C	1.4903 (10 CrMoVNb 91)	650°C		
4. sensor flange, always identically to sensor material.				
SM	flange according DIN			
SA	flange according ANSI			
5. seal sensor flange				
1	flanges acc. DIN, gasket strip form C, up to PN250 form Form E.			
2	flanges acc. ANSI, Dichtleiste RF			
3	Flansch nach ANSI, Dichtleiste SF (smooth finish)			
4	Flansch nach ANSI, Dichtleiste RTJ			
6. PN, material and DN of Sensor flange		DIN	ANSI	
A1	PN16 / 150 lbs	material: 1.5415 (15 Mo 3)	DN32	1 1/2"
A2	PN40 / 300 lbs	material: 1.5415 (15 Mo 3)	DN32	1 1/2"
A3	PN63 / 300 lbs	material: 1.5415 (15 Mo 3)	DN40	1 1/2"
A4	PN100 / 600 lbs	material: 1.5415 (15 Mo 3)	DN40	1 1/2"
A5	PN160 /1500 lbs	material: 1.5415 (15 Mo 3)	DN40	1 1/2"
A6	PN250 / 1500 lbs	material: 1.5415 (15 Mo 3)	DN40	1 1/2"
A7	PN320 / 2500 lbs	material: 1.5415 (15 Mo 3)	DN40	1 1/2"
A8	PN400 / 2500 lbs	material: 1.5415 (15 Mo 3)	DN40	1 1/2"
B1	PN16 / 150 lbs	material: 1.7335 (13 CrMo 4 4)	DN32	1 1/2"
B2	PN40 / 300 lbs	material: 1.7335 (13 CrMo 4 4)	DN32	1 1/2"
B3	PN63 / 300 lbs	material: 1.7335 (13 CrMo 4 4)	DN40	1 1/2"
B4	PN100 / 600 lbs	material: 1.7335 (13 CrMo 4 4)	DN40	1 1/2"
B5	PN160 /1500 lbs	material: 1.7335 (13 CrMo 4 4)	DN40	1 1/2"
B6	PN250 / 1500 lbs	material: 1.7335 (13 CrMo 4 4)	DN40	1 1/2"
B7	PN320 / 2500 lbs	material: 1.7335 (13 CrMo 4 4)	DN40	1 1/2"
B8	PN400 / 2500 lbs	material: 1.7335 (13 CrMo 4 4)	DN40	1 1/2"
C1	PN16 / 150 lbs	material: 1.7380 (10 CrMo 9 10)	DN32	1 1/2"
C2	PN40 / 300 lbs	material: 1.7380 (10 CrMo 9 10)	DN32	1 1/2"
C3	PN63 / 300 lbs	material: 1.7380 (10 CrMo 9 10)	DN40	1 1/2"
C4	PN100 / 600 lbs	material: 1.7380 (10 CrMo 9 10)	DN40	1 1/2"
C5	PN160 /1500 lbs	material: 1.7380 (10 CrMo 9 10)	DN40	1 1/2"
C6	PN250 / 1500 lbs	material: 1.7380 (10 CrMo 9 10)	DN40	1 1/2"
C7	PN320 / 2500 lbs	material: 1.7380 (10 CrMo 9 10)	DN40	1 1/2"
C8	PN400 / 2500 lbs	material: 1.7380 (10 CrMo 9 10)	DN40	1 1/2"
D1	PN16 / 150 lbs	material: 1.4903 (10 CrMoVNb 91)	DN32	1 1/2"
D2	PN40 / 300 lbs	material: 1.4903 (10 CrMoVNb 91)	DN32	1 1/2"
D3	PN63 / 300 lbs	material: 1.4903 (10 CrMoVNb 91)	DN40	1 1/2"
D4	PN100 / 600 lbs	material: 1.4903 (10 CrMoVNb 91)	DN40	1 1/2"
D5	PN160 /1500 lbs	material: 1.4903 (10 CrMoVNb 91)	DN40	1 1/2"
D6	PN250 / 1500 lbs	material: 1.4903 (10 CrMoVNb 91)	DN40	1 1/2"
D7	PN320 / 2500 lbs	material: 1.4903 (10 CrMoVNb 91)	DN40	1 1/2"
D8	PN400 / 2500 lbs	material: 1.4903 (10 CrMoVNb 91)	DN40	1 1/2"
7. design assembly connecting pieces				
R	assembly connecting pieces with flange (standard)			
W	Weldolet-assembly connecting pieces and flange			

1. Order specification ITABAR-FLOW-Sensor, series IBFD-26-HT

8. assembly connecting piece with flange, identically to sensor flange.				
0	without flange			
M	flange according DIN, gasket strip form C			
A	flange according ANSI, gasket strip RF			
F	flange according ANSI, gasket strip SF (smooth finish)			
T	flange according ANSI, gasket strip RTJ			
9. material connecting piece, with flange (max. press. rat.)				
always identically to sensor flange.			DIN	ANSI
S15	1.5415 (15 Mo 3)	PN16 / 150 lbs	DN32	1 1/2"
S44	1.7335 (13 CrMo 4 4)	PN16 / 150 lbs	DN32	1 1/2"
S91	1.7380 (10 CrMo 9 10)	PN16 / 150 lbs	DN32	1 1/2"
S30	1.4903 (10 CrMoVNb 91)	PN16 / 150 lbs	DN32	1 1/2"
(not weld together with material 1.7335)				
S16	1.5415 (15 Mo 3)	PN40 / 300 lbs	DN32	1 1/2"
S45	1.7335 (13 CrMo 4 4)	PN40 / 300 lbs	DN32	1 1/2"
S92	1.7380 (10 CrMo 9 10)	PN40 / 300 lbs	DN32	1 1/2"
S31	1.4903 (10 CrMoVNb 91)	PN40 / 300 lbs	DN32	1 1/2"
(not weld together with material 1.7335)				
S17	1.5415 (15 Mo 3)	PN63 / 300 lbs	DN40	1 1/2"
S46	1.7335 (13 CrMo 4 4)	PN63 / 300 lbs	DN40	1 1/2"
S93	1.7380 (10 CrMo 9 10)	PN63 / 300 lbs	DN40	1 1/2"
S32	1.4903 (10 CrMoVNb 91)	PN63 / 300 lbs	DN40	1 1/2"
(not weld together with material 1.7335)				
S18	1.5415 (15 Mo 3)	PN100 / 600 lbs	DN40	1 1/2"
S47	1.7335 (13 CrMo 4 4)	PN100 / 600 lbs	DN40	1 1/2"
S94	1.7380 (10 CrMo 9 10)	PN100 / 600 lbs	DN40	1 1/2"
S33	1.4903 (10 CrMoVNb 91)	PN100 / 600 lbs	DN40	1 1/2"
(not weld together with material 1.7335)				
S19	1.5415 (15 Mo 3)	PN160 / 1500 lbs	DN40	1 1/2"
S48	1.7335 (13 CrMo 4 4)	PN160 / 1500 lbs	DN40	1 1/2"
S95	1.7380 (10 CrMo 9 10)	PN160 / 1500 lbs	DN40	1 1/2"
S34	1.4903 (10 CrMoVNb 91)	PN160 / 1500 lbs	DN40	1 1/2"
(not weld together with material 1.7335)				
S20	1.5415 (15 Mo 3)	PN250 / 1500 lbs	DN40	1 1/2"
S49	1.7335 (13 CrMo 4 4)	PN250 / 1500 lbs	DN40	1 1/2"
S96	1.7380 (10 CrMo 9 10)	PN250 / 1500 lbs	DN40	1 1/2"
S35	1.4903 (10 CrMoVNb 91)	PN250 / 1500 lbs	DN40	1 1/2"
(not weld together with material 1.7335)				
S21	1.5415 (15 Mo 3)	PN320 / 2500 lbs	DN40	1 1/2"
S50	1.7335 (13 CrMo 4 4)	PN320 / 2500 lbs	DN40	1 1/2"
S97	1.7380 (10 CrMo 9 10)	PN320 / 2500 lbs	DN40	1 1/2"
S36	1.4903 (10 CrMoVNb 91)	PN320 / 2500 lbs	DN40	1 1/2"
(not weld together with material 1.7335)				
S22	1.5415 (15 Mo 3)	PN400 / 2500 lbs	DN40	1 1/2"
S51	1.7335 (13 CrMo 4 4)	PN400 / 2500 lbs	DN40	1 1/2"
S97	1.7380 (10 CrMo 9 10)	PN400 / 2500 lbs	DN40	1 1/2"
S37	1.4903 (10 CrMoVNb 91)	PN400 / 2500 lbs	DN40	1 1/2"
(not weld together with material 1.7335)				
10. end support				
0	without end support (if build-laterally available.)			
P	material: 1.5415 (15 Mo 3)			
V	material: 1.7335 (13 CrMo 4 4)			
R	material: 1.7380 (10 CrMo 9 10)			
C	material: 1.4903 (10 CrMoVNb 91)			
11. condensate vessel with connection				
s. page 153				

1. Order specification ITABAR-FLOW-Sensor, series IBFD-36-HT

1. type of sensor				
36-HT	IBFD-36-HT			
2. inside diameter and wall thickness.				
ID / W.-thickn.	inside diameter and wall thickness in inches (or mm), please specify			
3. sensor material				
		max. op. temperature		
P	1.5415 (15 Mo 3)	530°C		
V	1.7335 (13 CrMo 4 4)	550°C		
R	1.7380 (10 CrMo 9 10)	570°C		
C	1.4903 (10 CrMoVNb 91)	650°C		
4. sensor flange, always identically to sensor material.				
SM	flange according DIN			
SA	flange according ANSI			
5. seal sensor flange				
1	flanges acc. DIN, gasket strip form C, up to PN250 form Form E.			
2	flanges acc. ANSI, Dichtleiste RF			
3	Flansch nach ANSI, Dichtleiste SF (smooth finish)			
4	Flansch nach ANSI, Dichtleiste RTJ			
6. PN, material and DN of Sensor flange				
			DIN	ANSI
A1	PN16 / 150 lbs	material: 1.5415 (15 Mo 3)	DN32	1 1/2"
A2	PN40 / 300 lbs	material: 1.5415 (15 Mo 3)	DN32	1 1/2"
A3	PN63 / 300 lbs	material: 1.5415 (15 Mo 3)	DN40	1 1/2"
A4	PN100 / 600 lbs	material: 1.5415 (15 Mo 3)	DN40	1 1/2"
A5	PN160 /1500 lbs	material: 1.5415 (15 Mo 3)	DN40	1 1/2"
A6	PN250 / 1500 lbs	material: 1.5415 (15 Mo 3)	DN40	1 1/2"
A7	PN320 / 2500 lbs	material: 1.5415 (15 Mo 3)	DN40	1 1/2"
A8	PN400 / 2500 lbs	material: 1.5415 (15 Mo 3)	DN40	1 1/2"
B1	PN16 / 150 lbs	material: 1.7335 (13 CrMo 4 4)	DN32	1 1/2"
B2	PN40 / 300 lbs	material: 1.7335 (13 CrMo 4 4)	DN32	1 1/2"
B3	PN63 / 300 lbs	material: 1.7335 (13 CrMo 4 4)	DN40	1 1/2"
B4	PN100 / 600 lbs	material: 1.7335 (13 CrMo 4 4)	DN40	1 1/2"
B5	PN160 /1500 lbs	material: 1.7335 (13 CrMo 4 4)	DN40	1 1/2"
B6	PN250 / 1500 lbs	material: 1.7335 (13 CrMo 4 4)	DN40	1 1/2"
B7	PN320 / 2500 lbs	material: 1.7335 (13 CrMo 4 4)	DN40	1 1/2"
B8	PN400 / 2500 lbs	material: 1.7335 (13 CrMo 4 4)	DN40	1 1/2"
C1	PN16 / 150 lbs	material: 1.7380 (10 CrMo 9 10)	DN32	1 1/2"
C2	PN40 / 300 lbs	material: 1.7380 (10 CrMo 9 10)	DN32	1 1/2"
C3	PN63 / 300 lbs	material: 1.7380 (10 CrMo 9 10)	DN40	1 1/2"
C4	PN100 / 600 lbs	material: 1.7380 (10 CrMo 9 10)	DN40	1 1/2"
C5	PN160 /1500 lbs	material: 1.7380 (10 CrMo 9 10)	DN40	1 1/2"
C6	PN250 / 1500 lbs	material: 1.7380 (10 CrMo 9 10)	DN40	1 1/2"
C7	PN320 / 2500 lbs	material: 1.7380 (10 CrMo 9 10)	DN40	1 1/2"
C8	PN400 / 2500 lbs	material: 1.7380 (10 CrMo 9 10)	DN40	1 1/2"
D1	PN16 / 150 lbs	material: 1.4903 (10 CrMoVNb 91)	DN32	1 1/2"
D2	PN40 / 300 lbs	material: 1.4903 (10 CrMoVNb 91)	DN32	1 1/2"
D3	PN63 / 300 lbs	material: 1.4903 (10 CrMoVNb 91)	DN40	1 1/2"
D4	PN100 / 600 lbs	material: 1.4903 (10 CrMoVNb 91)	DN40	1 1/2"
D5	PN160 /1500 lbs	material: 1.4903 (10 CrMoVNb 91)	DN40	1 1/2"
D6	PN250 / 1500 lbs	material: 1.4903 (10 CrMoVNb 91)	DN40	1 1/2"
D7	PN320 / 2500 lbs	material: 1.4903 (10 CrMoVNb 91)	DN40	1 1/2"
D8	PN400 / 2500 lbs	material: 1.4903 (10 CrMoVNb 91)	DN40	1 1/2"
7. design assembly connecting pieces				
R	assembly connecting pieces with flange (standard)			
W	Weldolet-assembly connecting pieces and flange			

1. Order specification ITABAR-FLOW-Sensor, series IBFD-36-HT

8. assembly connecting piece with flange, identically to sensor flange.				
0	without flange			
M	flange according DIN, gasket strip form C			
A	flange according ANSI, gasket strip RF			
F	flange according ANSI, gasket strip SF (smooth finish)			
T	flange according ANSI, gasket strip RTJ			
9. material connecting piece, with flange (max. press. rat.)				
always identically to sensor flange.			DIN	ANSI
S15	1.5415 (15 Mo 3)	PN16 / 150 lbs	DN50	2"
S44	1.7335 (13 CrMo 4 4)	PN16 / 150 lbs	DN50	2"
S91	1.7380 (10 CrMo 9 10)	PN16 / 150 lbs	DN50	2"
S30	1.4903 (10 CrMoVNb 91)	PN16 / 150 lbs	DN50	2"
(not weld together with material 1.7335)				
S16	1.5415 (15 Mo 3)	PN40 / 300 lbs	DN50	2"
S45	1.7335 (13 CrMo 4 4)	PN40 / 300 lbs	DN50	2"
S92	1.7380 (10 CrMo 9 10)	PN40 / 300 lbs	DN50	2"
S31	1.4903 (10 CrMoVNb 91)	PN40 / 300 lbs	DN50	2"
(not weld together with material 1.7335)				
S17	1.5415 (15 Mo 3)	PN63 / 300 lbs	DN50	2"
S46	1.7335 (13 CrMo 4 4)	PN63 / 300 lbs	DN50	2"
S93	1.7380 (10 CrMo 9 10)	PN63 / 300 lbs	DN50	2"
S32	1.4903 (10 CrMoVNb 91)	PN63 / 300 lbs	DN50	2"
(not weld together with material 1.7335)				
S18	1.5415 (15 Mo 3)	PN100 / 600 lbs	DN50	2"
S47	1.7335 (13 CrMo 4 4)	PN100 / 600 lbs	DN50	2"
S94	1.7380 (10 CrMo 9 10)	PN100 / 600 lbs	DN50	2"
S33	1.4903 (10 CrMoVNb 91)	PN100 / 600 lbs	DN50	2"
(not weld together with material 1.7335)				
S19	1.5415 (15 Mo 3)	PN160 / 1500 lbs	DN50	2"
S48	1.7335 (13 CrMo 4 4)	PN160 / 1500 lbs	DN50	2"
S95	1.7380 (10 CrMo 9 10)	PN160 / 1500 lbs	DN50	2"
S34	1.4903 (10 CrMoVNb 91)	PN160 / 1500 lbs	DN50	2"
(not weld together with material 1.7335)				
S20	1.5415 (15 Mo 3)	PN250 / 1500 lbs	DN50	2"
S49	1.7335 (13 CrMo 4 4)	PN250 / 1500 lbs	DN50	2"
S96	1.7380 (10 CrMo 9 10)	PN250 / 1500 lbs	DN50	2"
S35	1.4903 (10 CrMoVNb 91)	PN250 / 1500 lbs	DN50	2"
(not weld together with material 1.7335)				
S21	1.5415 (15 Mo 3)	PN320 / 2500 lbs	DN50	2"
S50	1.7335 (13 CrMo 4 4)	PN320 / 2500 lbs	DN50	2"
S97	1.7380 (10 CrMo 9 10)	PN320 / 2500 lbs	DN50	2"
S36	1.4903 (10 CrMoVNb 91)	PN320 / 2500 lbs	DN50	2"
(not weld together with material 1.7335)				
S22	1.5415 (15 Mo 3)	PN400 / 2500 lbs	DN50	2"
S51	1.7335 (13 CrMo 4 4)	PN400 / 2500 lbs	DN50	2"
S97	1.7380 (10 CrMo 9 10)	PN400 / 2500 lbs	DN50	2"
S37	1.4903 (10 CrMoVNb 91)	PN400 / 2500 lbs	DN50	2"
(not weld together with material 1.7335)				
10. end support				
0	without end support (if build-laterally available.)			
P	material: 1.5415 (15 Mo 3)			
V	material: 1.7335 (13 CrMo 4 4)			
R	material: 1.7380 (10 CrMo 9 10)			
C	material: 1.4903 (10 CrMoVNb 91)			
11. condensate vessel with connection				
s. page 153				

Pressure Rating Assembly Flange

Code	Material	Pressure rating	Operating temperature (°F)															
			Max Operating Pressure PSI															
			572	662	752	842	932	950	968	986	1004	1022	1040	1058	1076	1112	1148	1202
C1	C22.8	PN16 / 150 lbs	139	88														
S1	1.4571		169	161	161	147												
P1	1.5415		161	147	139	132	117											
R1	1.7335		176	161	174	139	139	117	102	88,2	73	59						
S1	1.7380																	
V1	1.4903																	
C1	C22.8	PN40 / 300 lbs	352	147														
S1	1.4571		382	382	367	352												
P1	1.5415		397	367	338	323	308											
R1	1.7335		441	396	382	352	352	294	250	220	191	147						
S1	1.7380																	
V1	1.4903																	
C1	C22.8	PN63 / 300 lbs																
S1	1.4571																	
P1	1.5415																	
R1	1.7335																	
S1	1.7380																	
V1	1.4903																	
C1	C22.8	PN100 / 600 lbs	882	808														
S1	1.4571		1014	970	940	882												
P1	1.5415		970	926	867	837	808											
R1	1.7335		1073	999	940	896	867	735	646	543	455	382						
S1	1.7380																	
V1	1.4903																	
C1	C22.8	PN160 / 1500 lbs	1411	1323														
S1	1.4571		1617	1543	1381	1396												
P1	1.5415		1558	1470	1381	1337	1293											
R1	1.7335		1705	1587	1514	1425	1381	1176	1029	882	735	602						
S1	1.7380																	
V1	1.4903																	
C1	C22.8	PN250 / 1500 lbs	2822	2058														
S1	1.4571		3101	2425	2352	2205												
P1	1.5415		3131	2205	2175	2102	2028											
R1	1.7335		3425	2499	2366	2234	2175	1764	1411	1264	1102	940						
S1	1.7380		3469	2616	2499	2381	2249	1778	1440	1308	1131	999	867	779				
V1	1.4903																	
C1	C22.8	PN320 / 2500 lbs	2822	2646														
S1	1.4571		3101	3087	2940	2675												
P1	1.5415		3131	2954	1778	2690	2601											
R1	1.7335		3425	3189	3028	2866	2793	2175	1764	1558	1396	1205						
S1	1.7380		3586	3351	3204	3057	2881	2263	1852	1675	1470	1293	1117	999				
V1	1.4903																	
R1	1.7335	PN400 / 2500 lbs	4454	4160	3983	3792	3513	2793	2175	1999	1690	1543						
S1	1.7380		4483	4189	3998	3822	3601	2866	2307	2087	1837	1617	1396	1249				
V1	1.4903																	

Combination Condensate Pots / Shut-Off Valves

Basically it is possible to use a combination of condensate pots and shut-off valves for sensor types IBFD-/IBFD21 and IBFD -25/26. Such combinations are welded directly onto the sensor head. Preferably such a construction is used in applications with high differential pressures.

Advantages are:

- low weight
- smaller dimensions
- quick local installation

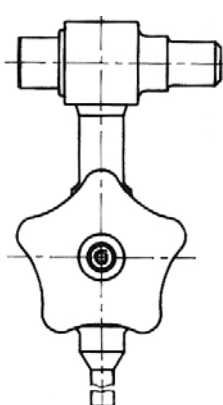
Schematic drawing	Description	Material	Code	Max. Operating Data	
				p PSI	At T (°F)
	Combination of condensate pot and shut-off valve process connection: welding boss 21 mm with graphite packing	15 Mo 3 1.5415	KV02	3675	248
				1764	932
		13 CrMo 4 4 1.7335	KV03	3675	248
				1837	1022
		10 CrMo 910 1.7380	KV04	2940	1742

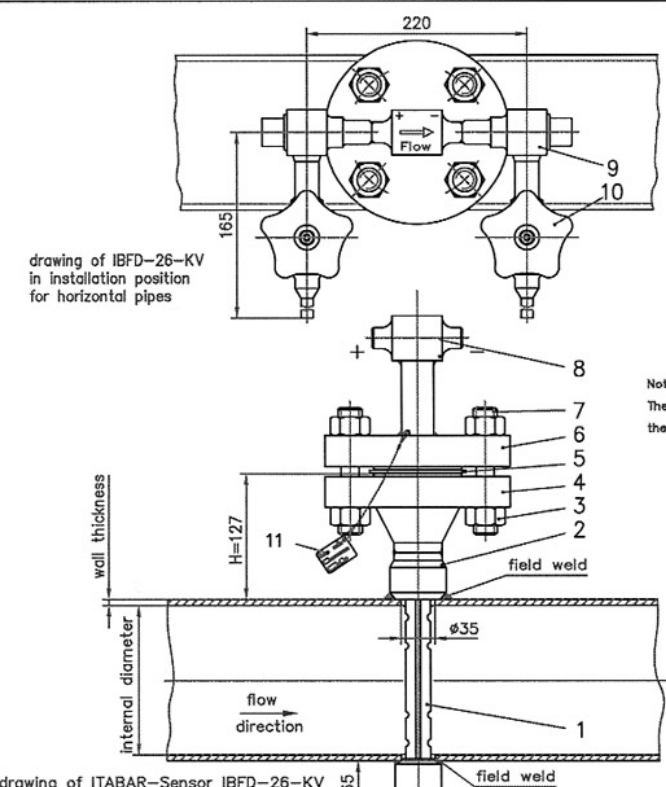

drawing of IBFD-26-KV in installation position for horizontal pipes

drawing of ITABAR-Sensor IBFD-26-KV without instrument connection

client	
quotation/order	
TAG no.	
internal pipe diameter	
wall thickness	
medium	
pressure	
temperature	
density	

pipe line

horizontal	vertical
<input type="checkbox"/>	<input type="checkbox"/>

Note:
The area of application of the arrangement depends on the used materials, the pressure rating, the flanges and the combination of alignment vessel and stop valve.

Item	description	quantity	material
12	closed end support	1	1.3CrMo44
11	TAG plate	1	316SS
10	shut-off valve	2	1.3CrMo44
9	condensation vessel	2	1.3CrMo44
8	sensor head with weld ends	1	1.3CrMo44
7	bolts M24	4	21 CrMo 57
6	Sensor flange DN40 PN250	1	1.3CrMo44
5	socket, spiral wound	1	1.3CrMo44/Grafit
4	WN-flange DN40 PN250	1	DIN 2828 1.3CrMo44
3	nuts M24	8	DIN 2510 21 CrMo 57
2	mounting stud	1	1.3CrMo44
1	Sensor profile #25	1	1.3CrMo44

Interpretation Condensate vessel

One important requirement for a trouble-free functioning of the ITABAR steam sensors is that the transition process from steam to condensate only takes place inside the condensate pots designed for this purpose. With this in mind different style condensate pots are offered for various operating conditions.

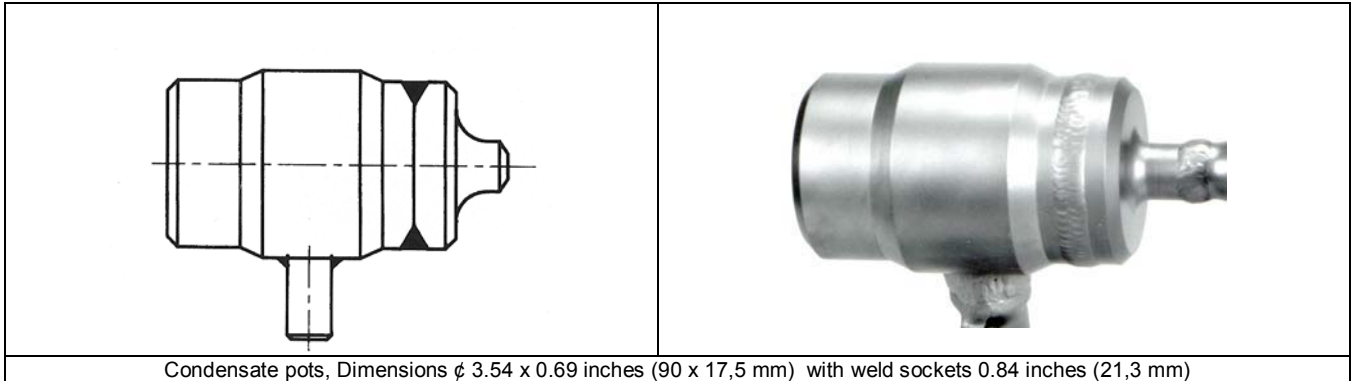

The following table gives the pressure rating of the condensate pots

Material st steel	Wall thickne ss mm	Operating temperature (°F)															
		Max Operating pressure / PSI															
		572	662	752	842	932	950	968	986	1004	1022	1040	1058	1076	1112	1148	1202
1.5415	4	1705	1499	1411	1323	1278	1264	1264									
1.7335	4	1911	1793	1675	1587	1528	1514	1514	1499	1484	1470	1176	1029				
1.7335	12,5				7350	6409	5350	4233	3454	2778	2175	1778	1440				
1.7380	15				7350	6556	5733	4968	4307	3719	3160	2734	2352	2013	1749		
1.4903	15																

Pressure- Temperature Table for Shut-Off Valves

Code	Description	Pressure Psi	Enclosure material abbrev name / DIN		Connections Inches	Packing	Used for
A13	Shut-off valves	5880	15 Mo 3	1.5415	0.85 x 0.13	graphite	IBFD-HT, IBFD-HTG
A14		5880	13 CrMo 4 4	1.7335	0.85 x 0.13	graphite	
A15		5880	10 CrMo 9 10	1.7380	0.85 x 0.13	graphite	
A16	Shut-off valve (component pest to TRD 110, TRB 801 Nr. 45)	4704	15 Mo 3	1.5415	0.85 x 0.13	graphite	IBFD-HT, IBFD-HTG
A17		4704	13 CrMo 44	1.7335	0.85 x 0.13	graphite	
A18		4704	10 CrMo 9 10	1.7380	0.85 x 0.13	graphite	
A19		5880	15 Mo 3	1.5415	1.06 x 0.2	graphite	
A20		5880	13 CrMo 44	1.7335	1.06 x 0.2	graphite	
A21		5880	10 CrMo 9 10	1.7380	1.06 x 0.2	graphite	
A22		5880	X10 CrMoVNb9-1	1.4903	1.06 x 0.2	graphite	

Code	Maximum operating pressure (PSI) at operating temperature °F																
	302	392	482	572	662	752	797	842	887	932	950	968	986	1004	1022	1040	1058
A13	5424	4983	4527	4086	3630	3189	2969	2734	2513	2278	2190	2102	2013	1925	1837	-	-
A14	5424	4983	4527	4086	3630	3189	2969	2734	2513	2278	2190	2102	2013	1925	1837	-	-
A15	5880	5880	5880	5880	5512	5145	4777	4410	4042	3675	3528	3381	3234	3087	2940	-	-

Code	Maximum operating pressure (PSI) at operating temperature °F																					
	572	662	752	797	842	887	932	950	968	986	1004	1022	1040	1058	1076	1094	1112	1130	1148	1166	1184	1202
A16	4704	4674	4380	4307	4233	4160	2631	1999	1572	1264	-	-	-	-	-	-	-	-	-	-	-	-
A17	4704	4704	4704	4704	4704	4630	4027	3366	2660	2175	1749	1367	-	-	-	-	-	-	-	-	-	-
A18	4704	4704	4704	4704	4704	4704	4204	3675	3189	2763	2381	2028	2028	1499	1293	-	-	-	-	-	-	-
A19	8085	7114	6659	6541	6423	6306	4263	3395	2704	2146	-	-	-	-	-	-	-	-	-	-	-	-
A20	8085	8085	7805	7570	7350	7247	6291	5321	4307	3572	2793	2249	-	-	-	-	-	-	-	-	-	-
A21	8085	8085	8085	8085	8026	7805	6188	5409	4718	4130	3572	3116	2660	2337	2013	-	-	-	-	-	-	-
A22	8085	8085	8085	8085	8085	8085	8085	8085	8085	8085	8085	7438	6659	4968	5277	4674	4130	3572	3116	2660	2337	2013



Fig. 8.14: Design of shut-off valves, materials:
15 Mo 3
13 CrMo 44
10 CrMo 910



Fig. 8.15: Design of shut-off valves, materials:
15 Mo 3
13 CrMo 44
10 CrMo 910
X10 CrMoVNb9-1

Order specification condensate vessel

IBFD-HT/HTG 26, 36

condensate vessel		material case	
		short name	material no.
K0	without condensate vessel		
K5	condensate vessel with welding stud 21,3mm size: ø 90 x 17,5 mm	15 Mo 3	1.5415
K6	condensate vessel with welding stud 21,3mm size: ø 90 x 17,5 mm	13 CrMo 4 4	1.7335
K7	condensate vessel with welding stud 21,3mm size: ø 80 x 12,5 mm	10 CrMo 9 10	1.7380
K8	condensate vessel with welding stud 21,3mm size: ø 80 x 12,5 mm	10 CrMoVNb 91	1.4903, not weld together with A14, A20

The material of the condensate vessel should correspond with the material of the stop valve.

Order specification connection and shut-off device

type IBFD-HT/HTG 26, 36

shut-off device for effect pressure pipe		material case		connection	packing
		short name	material no.		
A00	without shut-off valve				
A13	shut-off valve, nominal pressure: PN400	15 Mo 3	1.5415	21,3 x 3,2 mm	graphite
A14	shut-off valve, nominal pressure: PN400	13 CrMo 4 4	1.7335	21,3 x 3,2 mm	graphite
A15	shut-off valve, nominal pressure: PN400	10 CrMo 9 10	1.7380	21,3 x 3,2 mm	graphite

high-pressure shut-off valve acc. VdTÜV

A16	shut-off valve, nominal pressure: PN320 Component test acc. TRD 110, TRB 801 Nr.45	15 Mo 3	1.5415	21,3 x 3,2 mm	graphite
A17	shut-off valve, nominal pressure: PN320 Component test acc. TRD 110, TRB 801 Nr.45	13 CrMo 4 4	1.7335	21,3 x 3,2 mm	graphite
A18	shut-off valve, nominal pressure: PN320 Component test acc. TRD 110, TRB 801 Nr.45	10 CrMo 9 10	1.7380	21,3 x 3,2 mm	graphite
A19	shut-off valve, nominal pressure: PN500 Component test acc. TRD 110, TRB 801 Nr.45	15 Mo 3	1.5415	21,3 x 3,2 mm	graphite
A20	shut-off valve, nominal pressure: PN500 Component test acc. TRD 110, TRB 801 Nr.45	13 CrMo 4 4	1.7335	21,3 x 3,2 mm	graphite
A21	shut-off valve, nominal pressure: PN500 Component test acc. TRD 110, TRB 801 Nr.45	10 CrMo 9 10	1.7380	21,3 x 3,2 mm	graphite
A22	shut-off valve, nominal pressure: PN500 Component test acc. TRD 110, TRB 801 Nr.45	10 CrMoVNb 91	1.4903	21,3 x 3,2 mm	graphite

If double stop valves are required please to code, for example: A13-A13

Combination condensate vessel and shut-off valve

IBFD-HT/HTG 26, 36

shut-off device for effect pressure pipe		material case		packing
		short name	DIN material no.	
KV02	condensate vessel and shut-off valve as weld unit, welding stud 21,3 mm	15 Mo 3	1.5415	graphite
KV03	condensate vessel and shut-off valve as weld unit, welding stud 21,3 mm	13 CrMo 4 4	1.7335	graphite
KV04	condensate vessel and shut-off valve as weld unit, welding stud 21,3 mm	10 CrMo 9 10	1.7380	graphite