

4. Advantages of ITABAR-Pitot Tube Sensors

4.1 Advantages in Comparison to Orifice Plates

4.1.1 Lower Installation Costs

Compared to an orifice plate the ITABAR-sensor reduces material- and labor costs for the installation as well as operating expenses.

Part of the installation material costs of an ITABAR-sensor are the expenses for a weld boss and – depending on the sensor type – for a counter support fitting. The material costs for an orifice installation consist of two flanges and the necessary screws and hardware. The advantage in the ITABAR-sensors material costs are especially high for: large diameter pipes, pipe materials of exotic materials because of chemical compatibility issues, pipes for high pressure applications.

Labor costs for an ITABAR-sensor or orifice plate installation must include the wages for the welders. The installation of a weld boss requires – depending on the sensor type – a weld seam of approx. 10 cm (4"). The installation of a DN100 /4" (DN500/20") requires a weld seam of approx. 36 cm /14" (approx. 628"). The time needed to install an orifice plate is approx. 12 hours, as compared to approx. 1.5 hours for an ITABAR-sensor. The ITABAR-sensor in this case saves 10.5 labor hours.

The total savings in material- and labor costs which can be realized by using an ITABAR-sensor are at least 25% in a 4" pipe installation and at least 70% in a 20" pipe installation.

4.1.2 Bi-Directional Flow Measurement

The profile of all ITABAR-pitot tube sensors is designed to be symmetrical to the plane between the pressure channels. This arrangement results in the same resistance values and thus the same k-factor with respect to the fluid properties during forward as well as reverse flow. The differential pressures generated by a given flow velocity are the same for flow in either direction. They only differ in the +/- sign

This constitutes an advantage over to the orifice plate, see Fig 4.1), which - because of its angled downstream corner – has different resistance values for forward and reverse flows. It would indicate widely different differential pressures for the same flow velocity in opposite directions.

The differential pressure measurement and processing can be accomplished with either one or two signal converters. The use of two signal converters is justified in cases requiring a high resolution or if separate signals are needed for forward and reverse flow.

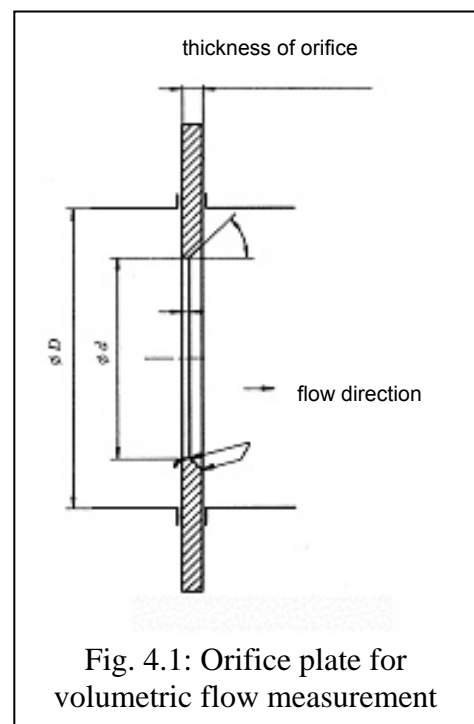

Fig. 4.1: Orifice plate for volumetric flow measurement