

***ULTRASONIC FLOW MEASUREMENT  
INSTRUMENT WITH CLAMP-ON SENSORS***

***Type: IntraSonic IS-200***



**Average transit time sound measurement between ultrasound transmitter and ultrasound receiver in the direction of liquid flow , as well as opposite the direction to calculate volumetric flow, average flow velocity and sonic speed in a liquid.**

**List of contents**

<b>1.</b>	<b>Introduction to Ultrasonic Flow Measurement</b>	<b>2</b>
<b>2.</b>	<b>Advantages of IntraSonic with Clamp-On Sensors</b>	<b>3</b>
2.1	Advantages at a glance	3
2.2	Installation without interrupting the process	3
2.3	Two assembly options are available	4
2.4	Simple installation on the pipe	5
<b>3.</b>	<b>Requirements for a successful installation</b>	<b>6</b>
3.1	Liquid requirements	6
3.2	Pipe requirements	6
3.3	Flow profile requirements	7
3.4	Installation requirements	8
<b>4.</b>	<b>Specifications of the measurement location</b>	<b>10</b>
<b>5.</b>	<b>IntraSonic IS200</b>	<b>11</b>
5.1	IS200-S for fixed installation	11
5.1.1	Order code IS200-S	11
5.1.2	Specification IS200-S-0	12
5.1.3	Specification IS200-S-A-1	13
5.1.4	Specification IS200-S-B-1	14
5.2	IS200-P for portable use	15
5.2.1	Order code IS200 P	15
5.2.2	Included in delivery	15
5.2.3	Specifications IS200-P-0-1	16
<b>6.</b>	<b>Transducers</b>	<b>17</b>
6.1	Order code transducers	17
6.2	Mounting rails	17
6.2.1	Order code mounting rails	18
6.3	Ultrasonic paste	18
6.3.1	Order code ultrasonic paste	18
6.4	Order code connection cables for transducers	18
<b>7.</b>	<b>Accessories</b>	<b>19</b>
7.1	Order code manuals	19
7.2	Order code PC-Software IS-Win	19
<b>8.</b>	<b>Calibration</b>	<b>20</b>
<b>9.</b>	<b>IS200 for rent</b>	<b>21</b>

# 1. Introduction to Ultrasonic Flow Measurement



Volumetric flow measurement by means of ultrasound was firstly suggested by von Rütten in 1931. Basic practice research goes back to the 1950s and dealt with the measurement of flow velocities in open channels and volumetric flow measurement in pipes and channels. Today's ultrasonic flow measuring devices can be classified by their installation method into two groups:

- Installation into the pipe, so called intrusive assembly and
- Non-intrusive installation to the outside of the pipe with strap-on sensors.

The advantage of an installation and measurement without having to shut down the process was recognized in all industrial segments and was the primary reason for the rapid deployment of this technology. The following list shows some of the many possible applications:

**Power plants:**

- Measurement of cooling water / boiler feed water / condensate
- Measurement of thermal energy flows

**Petrochemical industry:**

- Leak detection in pipelines
- High pressure flow measurement

**Water- and waste water industry:**

- Process measurement on large pipes
- Distribution and consumption measurement
- Leakage and test of water meters

**Food & beverage industry:**

- Non-contact sanitary flow measurement, steam sterilization possible

**Ship building:**

- Control of cooling and lubrication cycles
- Measurement of fuel consumption

**Chemical industry:**

- Non-intrusive measurement, especially for aggressive or poisonous media
- Measurement of non-conductive media
- Portable and thus mobile service

## 2. Advantages of IntraSonic with Clamp-On Sensors

### 2.1 Advantages at a glance

IntraSonic is an ultrasonic flow measurement instrument designed to measure volumetric flow inside a pipe. Its working principle is the measurement of transit time differentials. It can also measure average flow velocities and fluid concentrations in closed pipes. The main advantages of IntraSonic are:

- **Simple and cost effective installation onto the pipe**
- **Quick and easy functionality tests of other measurement systems**

Further advantages:

- **Cost effective and simple method to measure flow at different locations.**
- **Cost effective solution for large pipes or high pressures**
- **No pressure loss**
- **Measurement of sonic speed (e.g to measure concentrations)**
- **Clear and simple instrument operation**
- **Meaningful functionality checks to evaluate the received signals**
- **Detailed error- and status messages facilitate error corrections**

### 2.2 Installation without process interruption

With current technology only a few flow measuring devices can retroactively be installed at a measurement location without having to interrupt the process. The instrument selection must take into consideration: type of liquid to be measured, required accuracy, purchase-, installation- and operating costs. The following table compares the two available ultrasonic measurement methods. The IntraSonic ultrasonic instrument will be the first choice for many flow measurement applications requiring a retroactive installation without process shut-down.

Measurement principle of ultrasound instrument	Liquids to be measured	Pipe intrusion required ?	Method to measure average flow velocity	Accuracy as % of rate	Installation costs
Transmit time differential principle	Liquids with air or gas portion of < 3 Vol. %	No	Averaging along ultrasound path between sensors	± 1	low
Doppler principle	Liquids with near homogenous distribution of air, gas or particles	No	Averaging in narrowly defined ultrasound path	± 3 - 10	low

**2.3 Two installation methods are available**

The instrument allows two operating modes: „direct-mode“ and „reflective-mode“.

In direct-mode both sensors are installed oppositely to each others on the pipe wall. The sound wave crosses the pipe once. (see fig. 3.1)

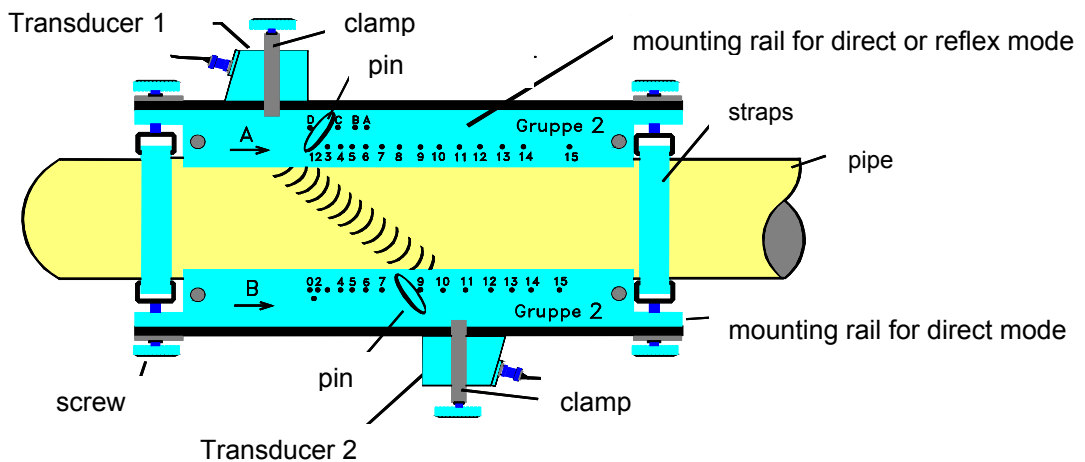

Fig. 3.1: Pipe with ultrasonic converters mounted in direct mode.

In reflective-mode both ultrasonic converters are installed on the same side of the pipe (see Fig 3.2). The sound wave crosses the pipe twice.

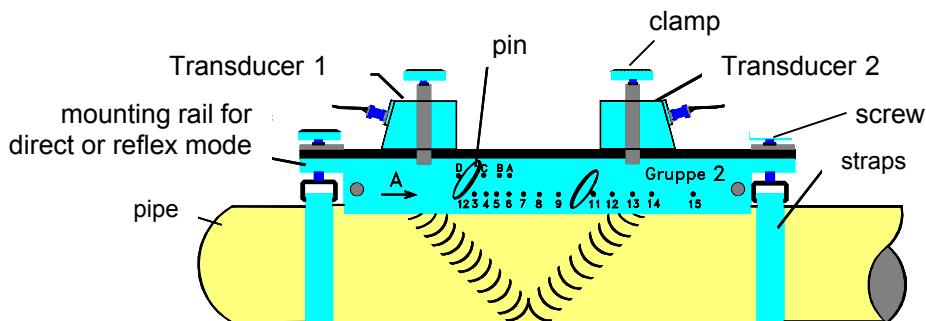

Fig 3.2: Pipe with ultrasonic converters mounted in reflective-mode

**2.4 Simple installation on the pipe**

The direct-mode assembly requires two assembly rails, the reflective-mode assembly requires one assembly rail. These rails have marked bore holes indicating the converter positions. The distance between converters is calculated and indicated by the instrument.

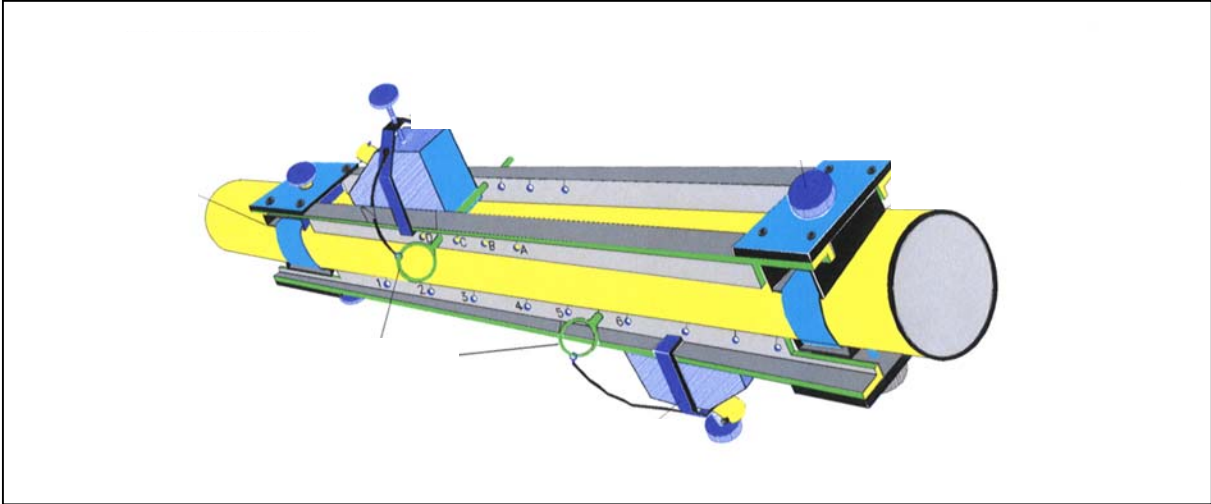

Fig 3.3: Required converter assembly components

## 3 Requirements for a successful installation

### 3.1 Liquid requirements

#### Completely filled pipe

During the measurement process the pipe must be completely filled with liquid. Liquids in partially filled pipes cannot be measured.

#### Small amounts of entrained air or gas

Air- and gas content, which is not absorbed in the liquid but is present in the form of bubbles can reflect the sound waves in an unpredictable manner and thus disturb the measurement. As a practical guideline gas and air should not exceed 3% by volume.

#### Small amounts of particles

Particles can also reflect the sound wave. Examples are liquids with a high degree of inorganic matter, e.g. minerals or metallic particles.

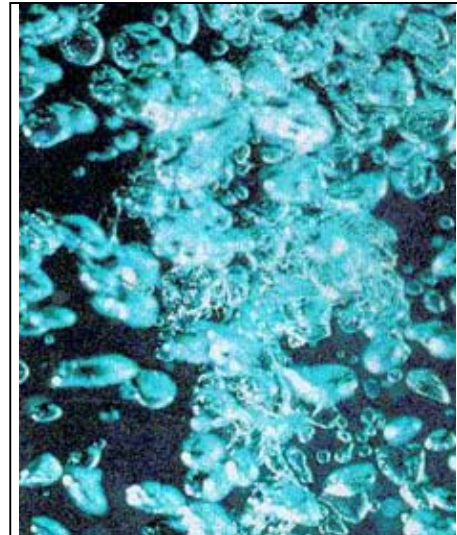

Fig. 4.1: Liquids containing a high degree of air and gas reflect the sound wave unpredictably and disturb the measurement

### 3.2 Pipe requirements

#### Good sound propagation

A decisive factor for a proper functioning of the instrument is the ability of the pipe material to allow the sound waves to propagate. The measurement path consists of the liquid, the pipe wall and possibly a pipe liner. If small amounts of deposits can accumulate on the bottom of the pipe it is advisable to mount the sensors in a horizontal position. A good sound propagation is thus ensured even with deposits on the bottom inside pipe wall.

#### Suitable pipe materials

Suitable pipe materials are most metals, synthetics and glass. Pipeline materials with a fine crystal structure (such as carbon- and rust free steels) are mostly stronger propagating as compared to cast iron-, pig iron- and copper pipes, even though these are also usable. Pipes made of cement or non-homogenous materials cannot be used.

#### Lined pipes

Lined pipes do not present a problem, as long as the liner is a material which allows sound to propagate and the liner is fixed to the pipe wall. Some acceptable liners are cement coating, thin bitumen layers or epoxy coats.

### Surface of pipe

The surface of the pipe also should meet ultrasonic requirements:

- The pipe is to be cleaned of dirt, corrosion or deposits.
- Thick coats of paint on the pipe wall at the intended place of instrument installation need to be removed. Thinly applied paints with good adhesion might be acceptable.
- Pipe irregularities at the sensor location (e.g. welding seam) should be avoided, since they can effect the direction of a sound wave.

### 3.3 Flow profile requirements

#### A rotation symmetrical flow profile is ideal

An exact volumetric flow calculation requires flow information from across the entire pipe diameter. Ultrasonic flow measurement devices however do not measure the flow velocity across the entire pipe diameter, but only between the two converters. The flow between the two converters should be free of eddies because these would also be measured by the system. Such eddies detrimentally change the flow profile.

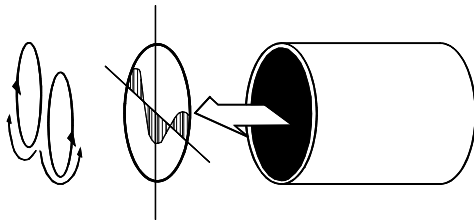

Eddies, with one 90°-bend on upstream side

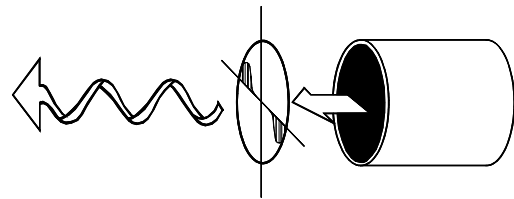

Eddies, with two 90°-bends on upstream side

#### Improvement of flow profile

To improve the flow profile and thus the measurement accuracy straight pipe runs up- and downstream of the sensors are required. The length of these pipe runs is given in multiples of pipe O.D.

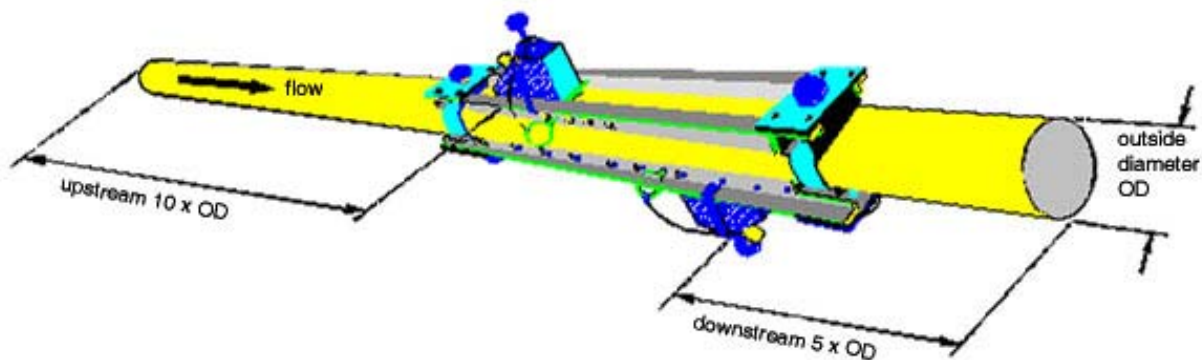

Flow profile disturbance		Minimum upstream runs (multiples of pipe OD)	Minimum downstream runs (multiples of pipe OD)
90°- bend	Two bends	10	5
	Two bends in same plane	13	5
	Three or more bends in same plane	15	5
	Two bends in different planes	15	5
	Three bends in different planes	20	5
Expansion	Pipe expansion w/ $\alpha/2 > 7^\circ$ ( $\alpha/2$ : angle to pipe axis)	10	5
	Pipe expansion w/ $\alpha/2 < 7^\circ$	0	5
Reducer	Pipe reduction w/ $\alpha/2 > 7^\circ$ ( $\alpha/2$ : angle to pipe axis)	10	5
	Pipe reduction w/ $\alpha/2 < 7^\circ$	0	5
T-piece		20	5..10
Valve	Any degree of opening	40	5
Pump		25	5

### 3.4 Installation requirements

#### Installation recommendations for horizontal pipes

In horizontal pipes the measuring path should if possible also run in a horizontal direction – see Fig.. 4.8. A deviation from the horizontal plane by  $\pm 60^\circ$  is allowed. A vertical installation is to be avoided for these reasons:

- Sound reflective gas bubbles can be carried along in the upper part of the pipe.
- Contaminations can be carried or be deposited in the pipe's lower part, thus dampening the sound waves.

The ultrasound converters should not be installed in the upper part of a u-shaped pipe, as shown in Fig. 4.9,. Air- or gas bubbles tend to accumulate at this location.

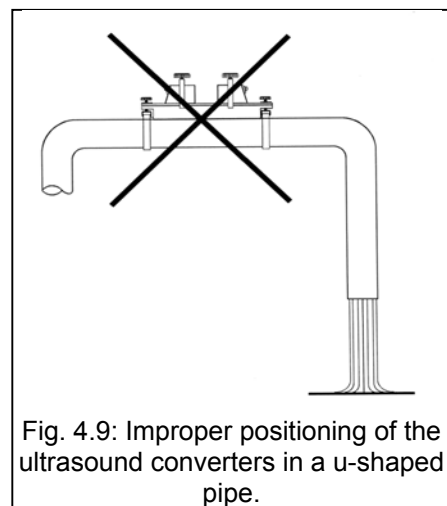
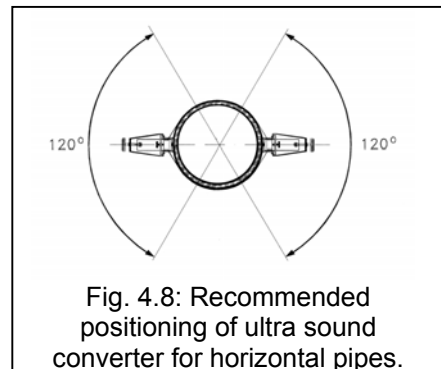

**Installation recommendation for vertical pipes**

In vertical pipes an upward flow direction is recommended, see Fig. 4.9. The reason: gas bubbles rise when there is no flow and thus leave the measurement location.

Installations in vertically downward flows with downstream pipe openings are to be avoided, see Fig. 4.10. The likelihood of the pipe running empty back to the measurement location is too great. Fig 4.11 illustrates a possible remedy if no other measurement location is available: a back pressure is to be created large enough to maintain a full pipe.

**Several ultrasonic instruments on the same pipe**

Measurement errors can be created if a second ultrasonic instrument of the same or another make is installed near-by. This is not the case for the dual-channel IntraSonic unit because of a shift in its sound waves.

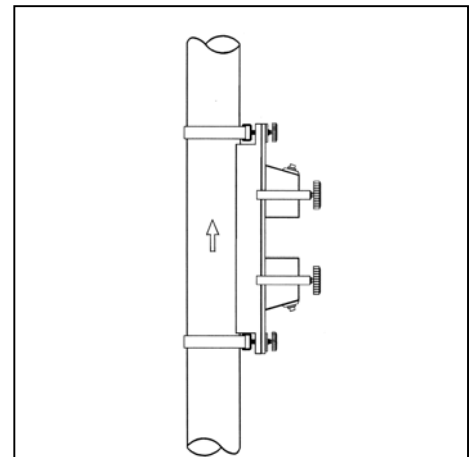

Fig. 4.9: Recommended ultrasonic converter positioning in vertical pipes

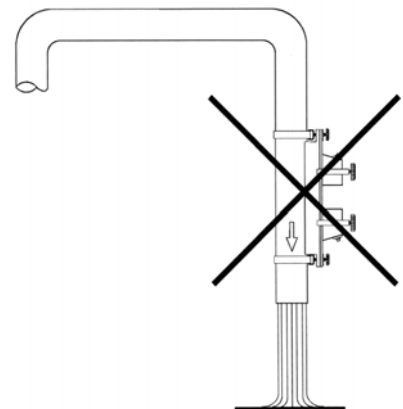

Fig. 4.10: Not recommended positioning of the ultrasonic converter in vertically downward flow

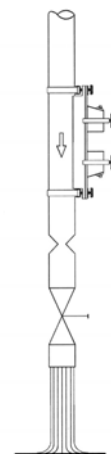

Fig. 4.11: Possible positioning of the ultrasonic converters in a vertically downward flow with a downstream valve

**Pipeline:**

Pipe material:

Pipe outside diameter (O.D.):  mm

Pipe wall thickness:  mm

Inlet straight undisturbed length acc. to recommendations?  
(if NO, please sketch the installation location) YES  NO

Outlet straight undisturbed length acc. to recommendations?  
(if NO, please sketch the installation location) YES  NO

Pipe completely filled during operation? YES  NO

Pipe accessible?  
(unobstructed 15 cm all around the pipe at place of measurement) YES  NO

**Liquid:**

Name:

Solids entrained?  
(if YES, please provide description and concentration) YES  NO

Gas / air bubbles entrained in liquid?  
(if YES, please provide concentration) YES  NO

**4 Specifications for the location of measurement**

Physical Values:	Desired Unit-of-measure	Min. value:	Oper.value:	Max. value:
Flow				
Temperature				

Peculiarities of measurement location :



## 5.1.2 Specifications IS200-S-0

### Measurement

Meas. Principle:	runtime-difference-principle
Flow velocity:	0,01 - 20m/s
Resolution:	0,01 cm/s
Accuracy:	±1%..5% of MV (for rotation-symmetric fully complying flow profile)
Response time:	1 - 5s adjustable
Damping:	1-100s
Meas. cycles:	400 per second
Measurable liquids:	all sound-conductive liquids

### Transmitter General

Display:	2 x 16 digits Point matrix backlit
Human interface:	optical keyboard for field- programming
No. of channels:	1
Languages:	German or English
Supply voltage:	12-24VDC
Power consumption:	6W
Ambient temperature:	-20 bis +40 °C
Protection class:	IP 66
Housing Material	die-cast aluminium
Dimernsions	WxHxD: 115x270x205 mm
Weight :	3,8 kg
Storing temperature:	0 to 40°C

### Indication

Highest number:	15.000.000
Decimal places:	0 to 3 adjustable
Counter:	with overflow counter

### Memory

Type:	SRAM battery backed 25000 values (optionally)
Data preservation:	min. 7 years

### Clock

Type:	quartz exact battery backed
Function:	time/date
Data preservation:	min. 7 years

### Process input optional

Temperature:	2 inputs for RTD PT100 (3 wire system) -50 - +450 °C
Resolution:	0,05 °C
Wall thickness meas.	(optional)*

### Process output standard

Interface:	RS485 output of all measured values
------------	--

### Process output optional

Current:	1 or 2 outputs 4 - 20mA
Power supply:	internal 14V DC external max. 40V DC
R max. load	
Internal:	500Ω
External:	1500Ω
Resolution:	12 bit
Assignment:	Flow velocity, flow or temperature free scalable
Frequency:	1 or 2 outputs 0-5kHz / TTL
Assignment:	Flow velocity, flow or temperature (free scalable)
Pulse output:	1 Pulse output / 10mA
Assignment:	Optoisolated Totalizer flow
Relay:	1 changer, 30V DC / 1A
Assignment:	Error or limited value
Interface:	(Fieldbus)*

All outputs are galvanically isolated from the base unit.  
The analoge outputs can be selected as current or  
frequency output.

(...)\* in preparation



### 5.1.3 Specifications IS200-S-A-1

**Measurement**

Meas. Principle: runtime-difference-principle

Flow velocity: 0,01 - 20m/s  
 Resolution: 0,01 cm/s  
 Accuracy: ±1%..5% of MV  
 (for rotation-symmetric fully complying flow profile)

Response time: 1 - 5s adjustable

Damping: 1-100s  
 Meas. cycles: 400 per second

Measurable liquids: all sound-conductive liquids

**Transmitter  
 General**

Display: 2 x 16 digits Point matrix  
 backlit  
 Human interface: optical keyboard for field-  
 programming

No. of channels: 1  
 Languages: German or English

Powersupply UNenn 12 VDC  
 INenn 0,5 A  
 PNenn 6 W  
 Um 16 VDC

Ambient temperature: -20 bis +40 °C  
 Protection class: IP 66

Ignition protection class: Pressure-resistant  
 Enclosure

Material: die-cast aluminium  
 Dimernsions WxHxD: 115x270x205 mm  
 Weight : 3,8 kg  
 Storing temperature: 0 to 40°C

**Connection Transducers**

Allowed transducers: Transducers for Ex-areas  
 Version 2 and 3

Terminals: X1 and X2

**Indication**

Highest number: 15.000.000  
 Decimal places: 0 to 3 adjustable  
 Counter: with overflow counter

**Memory**

Type: SRAM battery backed  
 25000 values  
 (optionally)  
 Data preservation: min. 7 years

**Clock**

Type: quartz exact battery backed  
 Function: time/date  
 Data preservation: min. 7 years

**Process inputs optional**

Temperature: 2 inputs for RTD PT100  
 (3 wire system)  
 -50 - +450 °C  
 Resolution: 0,05 °C  
 Wall thickness meas. (optional)\*

**Process outputs standard**

Interface RS485  
 Output of all measured values

**Process outputs optional**

Current: 1 or 2 outputs  
 4 - 20mA  
 Supply voltage: internal 14V DC  
 R max. load 500Ω  
 Resolution: 12 bit  
 Assignment: Flow velocity, flow or  
 temperature  
 free scaleable  
 Frequency: 1 or 2 outputs  
 0 -5kHz / TTL  
 Assignment: Flow velocity, flow or  
 temperature  
 free scaleable  
 Pulse output: 1 Pulse output / 10mA  
 Optoisolated  
 Assignment: Totalizer flow  
 Relay: 1 x changer, 30V DC / 1A  
 Assignment: Error or limit  
 Interface: (Fieldbus)\*

All outputs are galvanically separated from the base device. The analogue outputs can be used as current or as fequency outputs.



**5.1.4 Specifications IS200-S-B-1**

**Measurement**

Meas. Principle: runtime-difference-principle

Flow velocity: 0,01 - 20m/s  
 Resolution: 0,01 cm/s  
 Accuracy: ±1%..5% of MV  
 (for rotation-symmetric fully complying flow profile)

Response time: 1 - 5s adjustable

Damping: 1-100s  
 Meas. cycles: 400 per second

Measurable liquids: all sound-conductive liquids

**Transmitter  
General**

Display: 2 x 16 digits Point matrix  
backlit

Human interface: optical keyboard for field-  
programming

No. of channels: 1  
 Languages: German or English

Powersupply **UNenn** 12 VDC  
**INenn** 0,5 A  
**PNenn** 6 W  
**Um** 16 VDC

Ambient temperature: -20 bis +40 °C  
 Protection class: IP 66

Explosion approval pressure resistant enclos.  
and intrinsically safe at  
X1 and X2

Material: die-cast aluminium  
 Dimernsions WxHxD: 115x270x205 mm  
 Weight : 3,8 kg  
 Storing temperature: 0 to 40°C

**Connection Transducers**

Allowed transducers: Transducers for Ex-area  
Version 1 to 3

Terminals X1 and X2

Electr. Data **I<sub>o</sub>** 0,6 A  
**P<sub>o</sub>** 0,34 W  
**U<sub>o</sub>** 16 V  
**L<sub>o</sub>** 0,05 mH  
**C<sub>o</sub>** 0,3 µF

**Indication**

Highest number: 15.000.000  
 Decimal places: 0 to 3 adjustable  
 Counter: with overflow counter

**Memory**

Type: SRAM battery backed  
25000 values  
(optionally)  
min. 7 years

Data preservation: min. 7 years

**Clock**

Type: quartz exact battery backed  
 Function: time/date  
 Data preservation: min. 7 years

**Process inputs optional**

Temperature: 2 inputs for RTD PT100  
(3 wire system)  
-50 - +450 °C

Resolution: 0,05 °C

Wall thickness meas. (optional)\*

**,Process outputs standard**

Interface RS485  
Output of all measured  
values

**Process outputs optional**

Current: 1 or 2 outputs  
4 - 20mA

Supply voltage: internal 14V DC

R max. load 500Ω

Resolution: 12 bit  
 Assignment: Flow velocity, flow or  
temperature  
free scaleable

Frequency: 1 or 2 outputs  
0 -5kHz / TTL

Assignment: Flow velocity, flow or  
temperature  
free scaleable

Pulse output: 1 Pulse output / 10mA  
Optoisolated  
Totalizer flow

Assignment:

Relay: 1 x changer, 30V DC / 1A  
 Assignment: Error or limit

Interface: (Fieldbus)\*

All outputs are galvanically separated from the base device. The analogue outputs can be used as current or as fequency outputs.

(...)\* in preparation

## 5.2 IS200-P for mobile application

The design of the type IS200-P for volume flow measurement has been optimized for portable operation.

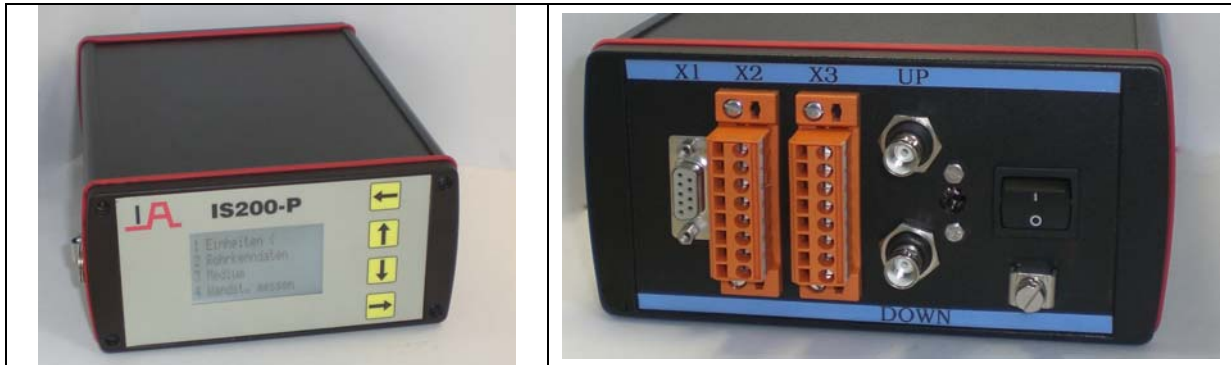

### 5.2.1 Order code IS200-P

<b>IS200-P-</b>	<b>Portable, RS485, accumulator battery for max. 7 hours operation</b>										
	<b>Explosion proof</b>										
	<b>0</b>	Not explosion proof									
		<b>Design</b>									
		<b>1</b>	One channel								
			<b>Menu language</b>								
			<b>E</b>	English							
			<b>G</b>	German							
			<b>OPTIONS</b>								
			<b>Analogue outputs</b>								
			<b>00</b>	Without							
			<b>A1</b>	Analogue output 4-20 mA							
			<b>Frequency outputs</b>								
			<b>00</b>	Without							
			<b>F1</b>	Frequency output: 0-5000 Hz TTL level							
			<b>Pulse outputs</b>								
			<b>00</b>	Without							
			<b>P1</b>	Pulse output: optocoupler isolated							
			<b>Alarm relays</b>								
			<b>00</b>	Without							
			<b>R1</b>	Alarm relay: changer isolated / max. load: 30 VDC / 1 A							
			<b>Connection for RTD</b>								
			<b>0</b>	Without							
			<b>T</b>	Connection for 2 RTD PT100							
			<b>Data logger</b>								
			<b>0</b>	Without							
			<b>M</b>	With data logger							
<b>IS200-P-</b>	<b>0</b>	<b>1</b>									

### 5.2.2 Included in delivery

IS200-S:

- serial connection cable for software update

IS200-P:

- carrying strap
- accumulator recharger 100-240 V AC / 50 and 60 Hz
- serial connection cable for software update

### 5.2.3 Specifications IS200-P-0-1

**Measurement**

Meas. Principle: Ultrasonic transit-time principle

Flow velocity: 0,01 - 20m/s  
 Resolution: 0,01 cm/s  
 Accuracy: ±1%..5% (of actual flow)  
 (for rotation-symmetric fully complying flow profile)

Response time: 1 - 5s adjustable

Damping: 1-100s  
 Measuring cycles: 400 per second

Measurable liquids: All sound conductive liquids

**Transmitter  
 General**

Display: 4 x 20 Indication point matrix with backlit

Human Interface: keyboard for direct programming

Number of channels: 1  
 Language: German or English

Power supply: 12 VDC charger

Rechargeable battery: 12V / 3,2 A/h  
 Max. operating time: 7h

Power consumption: 6 W  
 Ambient temperature: 0 bis +40 °C

Housing material: Aluminium  
 Size: WxHxD: 165x85x220 mm  
 Weight : 3,1 kg  
 Storage temperature: 0 bis 40°C

**Indicator**

Largest indication: 15.000.000  
 Floating point: 0 to 3 adjustable  
 Totalizing: with overflow counter

**Memory**

Type: SRAM battery operated  
 25000 measured value (optional)  
 Data preservation: min. 7 years

**Clock**

Type: Quarz exact battery operated  
 Function: Time/Date  
 Data memory: Min. 7 years

**Process input (optional)**

Temperature: 2 inputs for RTD PT100 (3 wire system)  
 -50 - +450°C  
 Resolution: 0.05 °C  
 Wall thickness meas: (optional)\*

**Process output standard**

Interface: RS485  
 Output of all measured values

**Process output optional**

Current: 1 output  
 4-20 mA  
 R max load: 500Ω  
 Resolution Assignment: 12 bit  
 Flow velocity, flow or temperature free scalable  
 Frequency: 1 output  
 0- 5kHz / TTL  
 Assignment: Flow velocity, flow or temperature free scalable  
 Pulse output: 1 Pulse output  
 Opto isolated / 10mA  
 Assignment: Totalizer  
 Relais: one changer, 30V DC / 1A  
 Assignment: Error or limited value

All inputs/outputs are galvanically isolated from the base unit. The analoge outputs can be selected as current or frequency output.



### 6.2.1 Ordering code mounting rails

S- Mounting rails						
Code	Transducer Group	Pipe outside diameter in mm	Mounting rails length in mm	Tightening straps length in mm	Mounting kit weight in kg	
10	1	13-100	280 ± 1	135	2,0	
20	2	32-200	395 ± 1	340	2,5	
30	3	150-610	760 ± 1	1300	4,0	
40	4	500-1070	1180 ± 1	2000	9,5	
50	5 + 6	910-5000	508/610 ± 1	40000	12,5	

S-

### 6.3 Ultrasonic paste

Ultrasonic paste to generate contact between transducers and the pipe surface.

#### 6.3.1 Ordering code ultrasonic paste

P- Ultrasonic paste				
Code	Type	Content in ml	Temperature range	
1	Water soluble	370	-23...+149 °C	
2	Not water soluble	90	-149...+230 °C	

P-

### 6.4 Ordering code connection cables (transducers)

L- Connection cables				
Code	Applicable for meas. device with transducers	Converted for connection to		
		IS200	Transducers	
0	IS200-S with transducers version 2 & 3	Clamped joint	Clamped joint	
1	IS200-S with transducers version 1 IS200-P with transducers version 2 & 3	Clamped joint	BNC	
		BNC	Clamped joint	
2	IS200-P with transducers version 1	BNC	BNC	
	<b>Code</b>	<b>Length</b>		
	1	5 m / 196,8"		
	2	10 m / 393,7"		
	3	15 m / 590,5"		
	4	30 m / 1181,7"		
	5	50 m / 1968,5"		

L-

**7. Accessories**

**7.1 Ordering code operation manual**

<b>BA-</b>	<b>Operation-/installation manual</b>	
	<b>Code</b>	<b>Quantity</b>
	D	x
	E	x
	C	x
		Manual German (1 copy free)
		Manual English (1 copy free)
		Manual on CD-ROM as pdf-files

BA-

**7.2 Ordering code PC-Software IS-WIN**

<b>ISW</b>	IS-WIN PC Software for data indication and software-update
------------	--

The screenshot displays the IS-WIN software interface. On the left, a diagram of a tank system is shown with several sensors: an Ultra Sonic flowmeter (INTRA SONIC), a Tank Level Gauge (MAGLINK), a Level Sensor (ITA-T1S), a Magnetic Level Gauge (ITA), and a Pitotube flowmeter (ITA-BAR). A central menu window titled 'IS-Win Version 1.01' is open, listing options: Datenanzeige, Software-Update Prozessor, Software-Update Ausgang, Konfiguration, Info, and Ende. To the right, there is promotional text: 'Specialists in flow and Level measurements', 'comes first!', and the logo for 'IA AUTOMATION' with 'ELEMENT & CONTROL' below it.

**PC-Software IS-WIN for data indication and Software-Update (min. required: Windows 2000)**

## 8. Calibration

Upon customer demand the ultrasound flowmeter measurement accuracy can be verified in independent calibration test labs or at the manufacturer's calibration facility, see Fig 10.1. Calibrations undertaken at the manufacturer's site are documented with a test certificate.



Fig. 10.1: Manufacturer's water calibration rig for pipe sizes 0.5 through 12 inches, max volumetric flow 400 m<sup>3</sup>/h (1760 GPM).

## 9. IS200 for rent

The ultrasonic flowmeter IntraSonic IS-100 can be rented on a weekly basis. Without big investments and without any risk a customer can take measurements without having to interrupt any process.

### Advantages at a glance:

- Ultrasound flow measurement at your facility done by your own personnel
- Registration of measured values
- Non intrusive measurement
- No process interruption and associated costs
- No investment risks
- Allows testing of the meter before purchasing
- 

### The rental includes:

- Weekly rental of IntraSonic incl.all necessary accessories
- The unit must be returned complete and undamaged
- Any required repair or cleaning costs are charged to the user
- Return freight costs to be paid by customer
- In case rental is substituted by purchase, the rental fee can become part of purchase cost upto 100% depending on the rental time
- The rented instruments are and remain the property of Intra-Automation







Otto-Hahn-Strasse 20  
41515 Grevenbroich  
GERMANY

Phone: +49 - (0) 21 81 – 7 56 65 – 0

Fax: +49- (0) 21 81 - 6 44 92

E-mail: [info@intra-automation.de](mailto:info@intra-automation.de)

Please also visit our homepage [www.intra-automation.de](http://www.intra-automation.de).