

0.075% ACCURACY  
120:1 RANGEABILITY

# LD301

SERIES  
SMART PRESSURE TRANSMITTERS



smar

- ✓ 0.075% accuracy
- ✓ 120:1 rangeability **NEW**
- ✓ 0-125 Pa to 0-40 MPa (0-0.5 inH<sub>2</sub>O to 0-5800 psi)
- ✓ Direct digital capacitance sensing (No A/D conversion)
- ✓ 4-20 mA output plus direct digital communication (HART® Protocol)
- ✓ True noninteractive zero and span
- ✓ Local zero and span adjustment
- ✓ Remote calibration
- ✓ Password protection
- ✓ On-line and off-line programming
- ✓ Multi-drop operation mode
- ✓ Output functions: linear,  $\sqrt{x}$ ,  $\sqrt{x^3}$ ,  $\sqrt{x^5}$ , special function and constant current
- ✓ Optional 4½-digit numerical and 5-character alphanumeric LCD indicator
- ✓ ISO 9001 certified
- ✓ Indication in engineering units, configuration file, diagnosis, etc., available in the Hand-Held Terminal (HT2)
- ✓ 16-point freely programmable output characterization
- ✓ Capable of handling most process fluids
- ✓ 14 MPa and 21 MPa static pressure (2000 psi and 3000 psi)
- ✓ Small and lightweight
- ✓ Explosion proof and weather proof housing
- ✓ Intrinsically safe
- ✓ Constant signal generation for loop tests
- ✓ Fully interchangeable parts for easy maintenance
- ✓ Optional PID control function with antireset wind-up, output limitation, rate-of-change limitation, bumpless auto/manual transfer, etc.
- ✓ Fail-safe level
- ✓ Flow totalization
- ✓ User unit
- ✓ Conforms to IEC 801



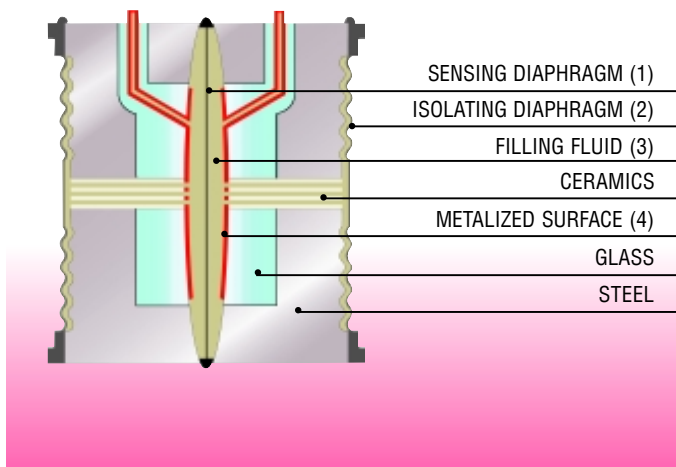

The **LD301** series uses, as its measuring principle, the well-known and field proven technique of capacitance sensing, enhanced by a microprocessor based electronics.

Designed for process control applications, these 2-wire transmitters generate a 4-20 mA signal proportional or characterized to the applied differential pressure. This signal can be transmitted over a pair of twisted wires through long distances (limited only by the wire resistance and load). Digital communication for remote calibration and monitoring is also provided, superimposing a digital signal on the same pair of wires that carries the 4-20 mA signal.

Remarkable features of the LD301 series are its 0.075% high accuracy, 120:1 rangeability, compactness and light-weightiness, PID control capability (optional), etc.

The transmitter consists of two main parts. The sensor (a capacitance variation cell) and the electronic circuit.

The sensor is schematically shown in the above drawing. A sensing diaphragm (1) is shown at the center of the cell. This diaphragm deflects, as a result of the difference between the pressures applied to the left and right sides of the sensor.

These pressures are directly applied to the isolating diaphragms (2), that provide isolation and resistance against process fluid corrosion. The pressure is transmitted to the sensing diaphragm through the filling Fluid (3).

The sensing diaphragm is also a moving capacitor plate, and the two metallized surfaces (4) are fixed plates. The sensing diaphragm deflection results in a variation on the capacitances between the moving and fixed plates.

The Electronic Circuit measures the variation of the capacitance between the moving and fixed plates, and generates a 4-20 mA signal, that can be proportional to the differential pressure applied or characterized (square root, special function, etc.) to it. Being microprocessor based, the electronic circuit is extremely versatile and accurate. Combined with the sensor precision, it provides the high accuracy and rangeability peculiar of the LD301 series. Transmitter performance is improved by continuous monitoring of the sensor temperature and corresponding corrections.

The transmitter can also operate as a combination of transmitter plus controller. In this case, the 4-20 mA signal is used as the output of a PID control function (optional), while the digital signal may be used for remote monitoring and operation.

## Sensor Assembly

## Main Processor Assembly

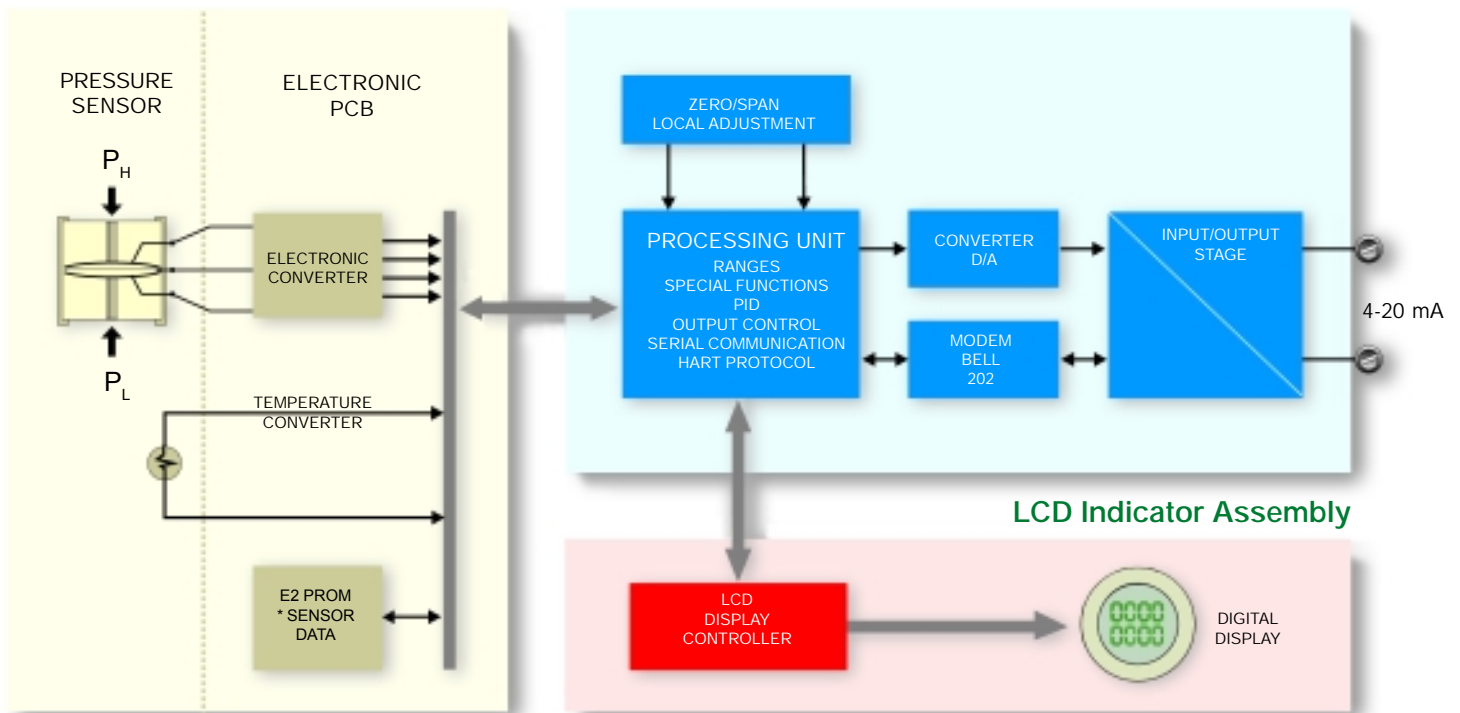

## CONSTRUCTION

**Wetted parts** of the sensor are available in the following materials:

- ✓ 316L Stainless Steel
- ✓ Hastelloy C™
- ✓ Monel 400™
- ✓ Tantalum

The isolating diaphragms are made of 316L stainless steel in the standard versions. They can optionally be provided in Hastelloy, Monel or Tantalum.

Process flanges and adapters are available in plated carbon steel, 316 stainless steel, Hastelloy C or Monel.

This ensures compatibility of the transmitter with most industrial fluids.

Electronic housing is available in the following materials:

- ✓ Aluminum
- ✓ 316 Stainless Steel

The electronic housing is a sturdy Explosion Proof and Weather Proof construction.

The electronic circuit boards are tropicalized and are intrinsically safe for use in hazardous areas.

The different versions are obtained as follows:

#### DIFFERENTIAL PRESSURE (DP)

Applying pressure to both sides of the sensor. This is also used in many level applications. For high static pressure applications the "H" model is available.



#### FLOW MEASUREMENT

The 4-20 mA signal can be made proportional to the square root of the differential pressure applied. It is normally used together with a primary flow element such as orifice plate, integral orifice, Venturi tubes, etc.

#### GAGE PRESSURE

Pressure is applied to one side of the sensor while the other side is open to atmosphere.



#### ABSOLUTE PRESSURE

A chamber is welded on one side of the sensor and then vacuum sealed. Pressure is applied to the other side of the sensor.



#### LEVEL

The transmitter is available as a flange mounted unit with a flush diaphragm, for direct installation on vessels. Extended diaphragms are also available. For food grade applications, see SR301 series catalog.



#### REMOTE SEALS

Separate diaphragm seals are installed in either one or in both sides of the sensor, providing further chemical and thermal isolation.

For food grade applications, Tri-clamp and other connections according 3-A standard compliant connections are available. See SR301 series catalog.



The **LD301** can be programmed by a Hand-Held Terminal (HT2) or PC (Personal computer) using the software CONF301, together with a SMAR HI311 interface (HART/RS232C).

The CONF301 is a configuration interface developed under the application MS Windows, so the human machine interface is extremely friendly.

Programming, reranging, PID adjustment (optional), setpoint changing, etc. are performed by both the HT2 and CONF301, when connected in parallel to any point of the 4-20 mA line. A single HT2 or computer can be used for programming any number of transmitters.

The local adjustment using the magnetic screwdriver allows, besides the zero and span adjustments, setpoint and other controller functions changing, totalization enabling, trim adjustments, etc.

CONF301 - CONFIGURATION SOFTWARE

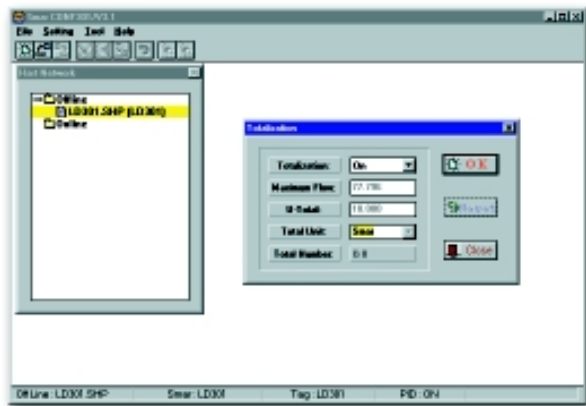

CONF301 - CONFIGURATION SOFTWARE



HAND-HELD TERMINAL HT2



LOCAL ADJUSTMENT

## CONNECTION DIAGRAM

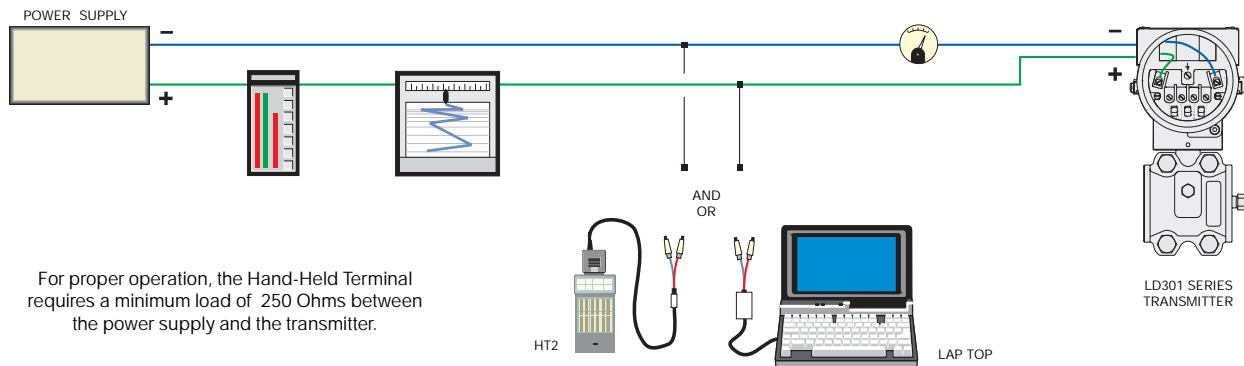

## Working as a Conventional Transmitter

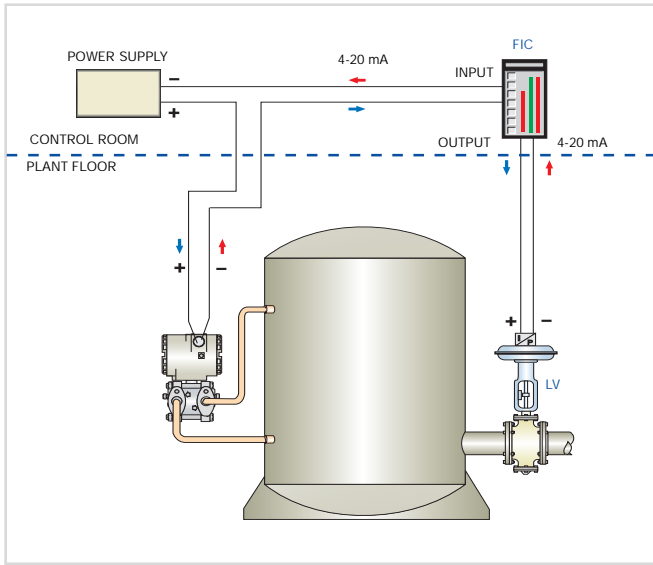

## Working as a Local Controller

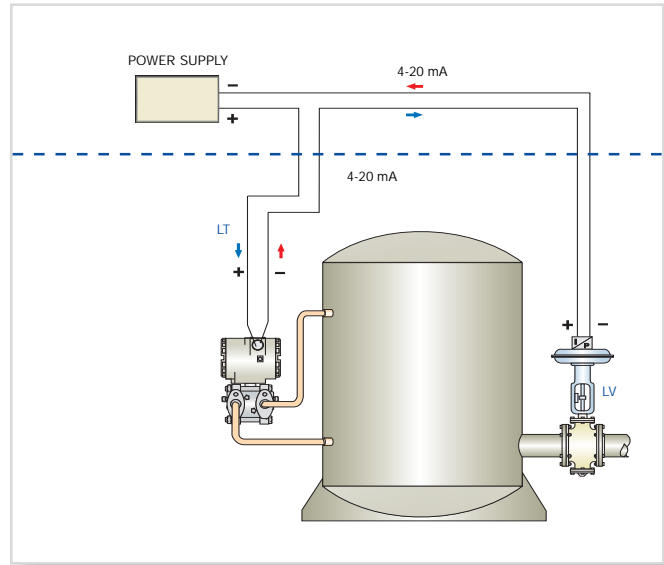

## Working as a Controller with Computer Supervision from the Control Room

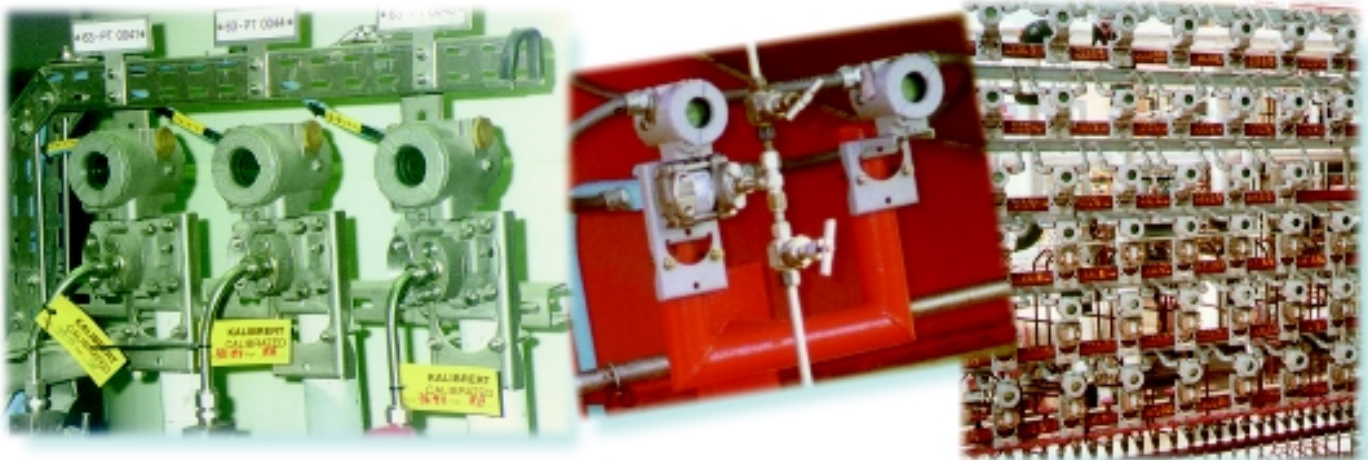
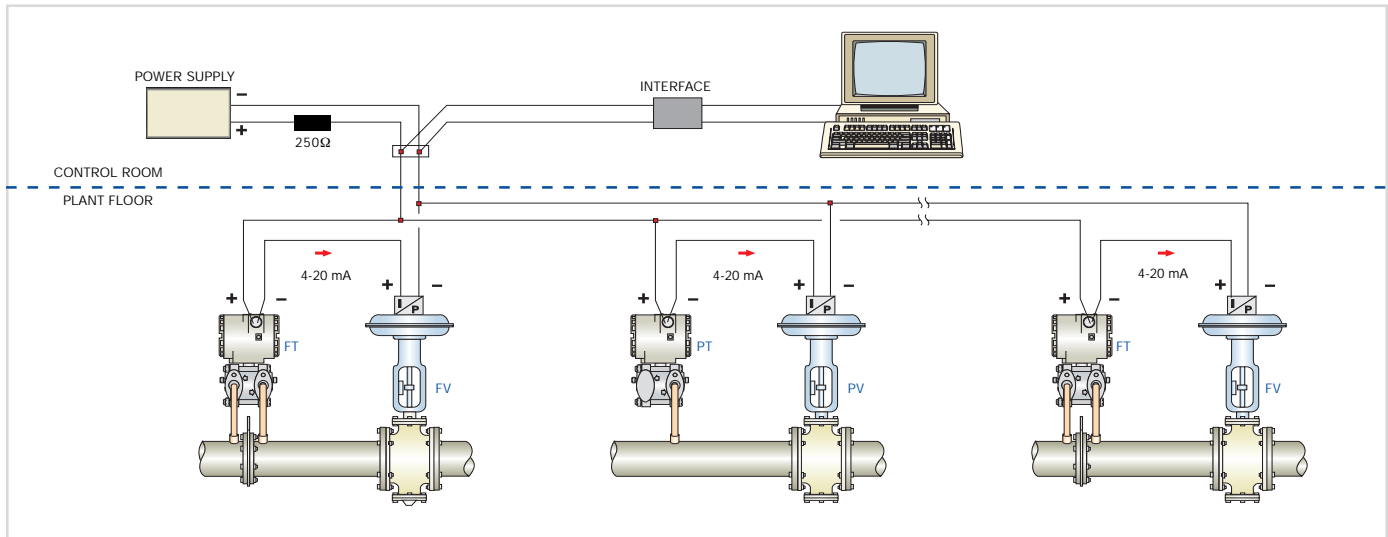

### Functional Specifications

#### Process Fluid

Liquid, gas or vapor.

**NEW**

#### Output Signal

Two-wire, 4-20 mA controlled according to NAMUR NE43 Specification, with superimposed digital communication (HART® Protocol).

#### Power Supply

12 to 45 Vdc.

#### Load Limitation

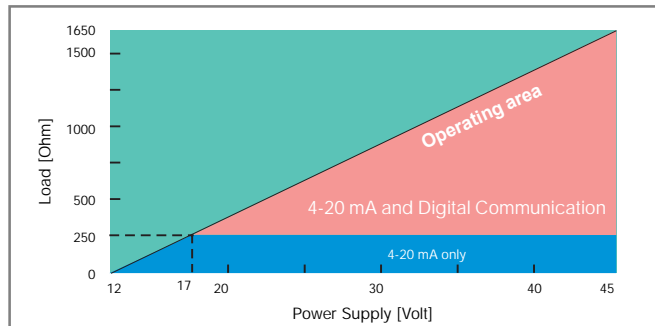

#### Indicator

Optional 4½-digit numerical and 5-character alphanumeric LCD indicator.

#### Hazardous Area Certifications

Explosion proof, weather proof and intrinsically safe (CENELEC and FM standards).

#### Zero and Span Adjustments

Noninteractive, via digital communication.

#### Zero Adjustment Limits

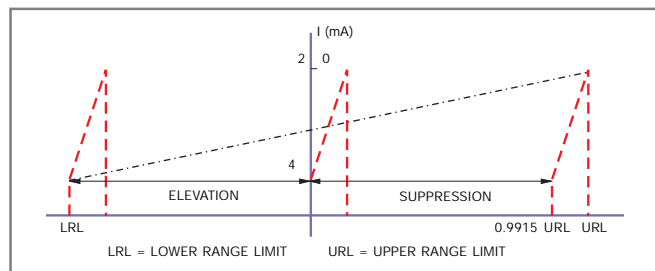

Calibrated span shall not be less than 0.0085 URL and shall not exceed 2 URL.

Low range value shall not be below LRL.

Upper range value shall not be greater than URL.

(LRL = -URL for all models, except absolute, where LRL = vacuum).

#### Temperature Limits

Ambient: -40 to 85 °C (-40 to 185 °F).  
 Process: -40 to 100 °C (-40 to 212 °F) (Silicone Oil).  
 0 to 85 °C (-32 to 185 °F) (Fluorolube Oil).  
 -40 to 150 °C (-40 to 302 °F) for LD301L.  
 -25 to 85 °C (-13 to 185 °F) (Viton O-Rings).  
 Storage: -40 to 100 °C (-40 to 212 °F).  
 Digital Display: -10 to 60 °C (14 to 140 °F).  
 -40 to 85 °C (-40 to 185 °F) without damage.

**NEW**

#### Failure Alarm

In case of sensor or circuit failure, the self diagnostics drives the output to 3.6 or 21.0 mA, according to the user's choice.

#### Turn-on Time

Performs within specifications in less than 5.0 seconds after power is applied to the transmitter.

#### Volumetric Displacement

Less than 0.15 cm<sup>3</sup> (0.01 in<sup>3</sup>).

#### Overpressure and Static Pressure Limits

From 3.45 kPa abs. (0.5 psia)\* to:

8 MPa (1150 psi) for range 1.

16 MPa (2300 psi) for ranges 2, 3 & 4.

32 MPa (4600 psi) for models H & A5.

40 MPa (5800 psi) for model M5.

52 MPa (7500 psi) for model M6.

\* except the LD301A model.

Flange Test Pressure: 60 MPa (8570 psi).

For ANSI/DIN Level flanges (LD301L models):

150lb: 6 psia to 275 psi at 38 °C (-0.6 to 19 bar).

300lb: 6 psia to 720 psi at 38 °C (-0.6 to 50 bar).

PN10/16: -60 kPa to 1.4 MPa at 120 °C.

PN25/40: -60 kPa to 4 MPa at 120 °C.

These pressures will not damage the transmitter, but a new calibration may be necessary.

#### Humidity Limits

0 to 100% RH.

#### Damping Adjustment

0 to 32 seconds in addition to intrinsic sensor response time (0.2s) (via digital communication).

#### Configuration

Can be done through digital communication using the Hart Protocol or, partially, through local adjustment.

#### Hand-Held Terminal Main Features (HT2)

An interface and a program datapack for LD301 are necessary for communication.

EPROM memory: 128 Kbytes, datapack.

Display: 80 characters, 4 lines.

Power supply: 9 Vdc.

Dimensions (LWD): (142 x 78 x 29.3 mm).

#### Performance Specifications

Reference conditions: range starting at zero, temperature 25 °C (77 °F), atmospheric pressure, power supply of 24 Vdc, silicone oil fill fluid, isolating diaphragms in 316L SS and digital trim equal to lower and upper range values.

#### Accuracy

0.1 URL ≤ span ≤ URL:

±0.075% of span;

0.025 URL ≤ span ≤ 0.1 URL:

±0.0375 [1+0.1 URL/span]% of span;

0.0085 URL ≤ span ≤ 0.025 URL:

±[0.0015+0.00465 URL/span]% of span (\*).

(\*) - Recommended minimum span for Range 1 is 0.025 URL.

For ranges 5 and 6, Absolute models, diaphragms in Tantalum, Monel or fill fluid in Fluorolube:

0.1 URL ≤ span ≤ URL:

± 0.1% of span;

0.025 URL ≤ span ≤ 0.1 URL:

±0.05 [1+0.1 URL/span]% of span;

0.0085 URL ≤ span ≤ 0.025 URL:

±[0.01+0.006 URL/span]% of span.

For Absolute - range 1:

± 0.2% of span

Linearity, hysteresis and repeatability effects are included.

### Stability

- ± 0.1% of URL for 24 months for ranges 2, 3, 4, 5 & 6.
- ± 0.2% of URL for 12 months for range 1 & L models.
- ± 0.25% of URL for 5 years, at 20 °C temperature change and up to 7 MPa (100 psi) of static pressure.

### Temperature Effect

- ± (0.02% URL+0.1% span) per 20 °C (36 °F) for ranges 2, 3, 4, 5 & 6.
- ± (0.05% URL+0.15% span) per 20 °C (36 °F) for range 1.

For LD301L:

6 mmH<sub>2</sub>O per 20 °C for 4" and DN100.

17 mmH<sub>2</sub>O per 20 °C for 3" and DN80.

Consult for other flange dimensions and fill fluid.

### Static Pressure Effect

Zero error:

± 0.1% URL per 7 MPa (1000 psi) for ranges 2, 3, 4 & 5, or 3.5 MPa (500 psi) for L models or 1.7 MPa (250 psi) for range 1. This is a systematic error that can be eliminated by calibrating at the operating static pressure.

Span error:

Correctable to ± 0.2% of reading per 7 MPa (1000 psi) for ranges 2, 3, 4 & 5 or 3.5 MPa (500 psi) for range 1 and L models.

### Power Supply Effect

± 0.005% of calibrated span per volt.

### Mounting Position Effect

Zero shift of up to 250 Pa (1 inH<sub>2</sub>O) which can be calibrated out. No span effect.

### Electro-Magnetic Interference Effect

Designed to comply with IEC 801.

## Physical Specifications

### Electrical Connection

½ - 14 NPT, Pg 13,5 or M20 x 1,5 metric.

### Process Connection

¼ - 18 NPT or ½ - 14 NPT (with adapter). For L models see ordering code.

### Wetted Parts

- Isolating Diaphragms  
316L SST, Hastelloy C276, Monel 400 or Tantalum.
- Drain/Vent Valves and Plug  
316 SST, Hastelloy C276 or Monel 400.
- Flanges  
Plated carbon steel, 316 SST, Hastelloy C276 or Monel 400.
- Wetted O-Rings (For Flanges and Adapters)  
Buna N, Viton™ or PTFE. Ethylene-Propylene on request.

The LD301 is available in NACE MR-01-75 compliant materials.

### Nonwetted Parts

- Electronic Housing  
Injected aluminum with polyester painting or 316 SST (NEMA 4X, IP67).
- Blank Flange  
Plated carbon steel, when the wetted flange is made of this same material, and 316 SST in the other cases.
- Level Flange (LD301L)  
316 SST.
- Fill Fluid  
Silicone or Fluorolube Oil.
- Cover O-Rings  
Buna N.
- Mounting Bracket  
Plated carbon steel with polyester painting or 316 SST. Accessories (bold, nuts, washers and U-clamps) in carbon steel or 316 SST.
- Flange Bolts and Nuts  
Plated carbon steel:  
Grade 7, 316 SST or Carbon Steel B7M (for nace applications).
- Identification Plate  
316 SST.

### Mounting

- Flange mounted for models LD301L.
- Optional universal mounting bracket for surface or vertical/horizontal (DN 50) 2"-pipe (optional).
- Via bracket on manifold valve (optional).
- Directly on piping for closely coupled transmitter/orifice flange combinations.

### Approximate Weights

3.15 kg (7 lb): all models, except L models.

5.85 to 9.0 kg (13 lb to 20 lb): L models depending on the flanges, extension and materials.

## Control Characteristics (optional)

PID

Proportional Gain: 0 to 100.

Integral Time: 0.01 to 999 min/rep.

Derivative Time: 0 to 999 s.

Direct / Reverse Action.

Lower and Upper output limits.

Output rate-of-change limit: 0 to 100%/s.

Power-on safety output.

Antireset windup.

Bumpless Auto/Manual transfer.

Hastelloy is a trademark of the Cabot Corp.

Monel is a trademark of International Nickel Co.

Viton and Teflon are trademarks of E. I. DuPont de Nemours & Co.

Fluorolube is a trademark of Hooker Chemical Corp.

Hart is a trademark of HART Communication Foundation.

MODEL LD301		DIFFERENTIAL, GAGE, ABSOLUTE AND HIGH STATIC PRESSURE TRANSMITTERS					
CODE	Type and Range (1)						
D1	Differential	0.125	to	5 kPa	0.5	to	20 inH <sub>2</sub> O
D2	Differential	0.417	to	50 kPa	1.67	to	200 inH <sub>2</sub> O
D3	Differential	2.08	to	250 kPa	0.3	to	36 psi
D4	Differential	20.8	to	2500 kPa	3	to	360 psi
M1	Gage	0.125	to	5 kPa	0.5	to	20 inH <sub>2</sub> O
M2	Gage	0.417	to	50 kPa	1.67	to	200 inH <sub>2</sub> O
M3	Gage	2.08	to	250 kPa	8.33	to	1000 inH <sub>2</sub> O
M4	Gage	20.8	to	2500 kPa	3	to	360 psi
M5	Gage	0.208	to	25 MPa	30	to	3600 psi
M6	Gage	0.333	to	40 MPa	48.3	to	5800 psi
A1	Absolute	2	to	5 kPa	14.8	to	37 mmHg
A2	Absolute	2.5	to	50 kPa	0.36	to	7.2 psia
A3	Absolute	2.08	to	250 kPa	0.3	to	36 psia
A4	Absolute	20.8	to	2500 kPa	3	to	360 psia
A5	Absolute	0.208	to	25 MPa	30	to	3600 psia
H2	Differential - High Static Pressure	0.417	to	50 kPa	1.67	to	200 inH <sub>2</sub> O
H3	Differential - High Static Pressure	2.08	to	250 kPa	0.3	to	36 psi
H4	Differential - High Static Pressure	20.8	to	2500 kPa	3	to	360 psi
H5	Differential - High Static Pressure	0.208	to	25 MPa	30	to	3600 psi
CODE	Diaphragm Material and Fill Fluid (Low Side)						
1	316L SST	Silicone Oil		<b>Note:</b> Absolute Models are not available with Fluorolube Oil. Tantalum and Monel diaphragm are not available for Range 1.			
2	316L SST	Fluorolube Oil					
3	Hastelloy C276	Silicone Oil*					
4	Hastelloy C276	Fluorolube Oil*					
5	Monel 400	Silicone Oil					
7	Tantalum	Silicone Oil					
8	Tantalum	Fluorolube Oil					
Z	Others - Specify						
CODE	Flange(s), Adapter(s) and Drain/Vent Valves Materials						
C	Plated CS (Drain/Vent in Stainless Steel)						
I	316 SST						
H	Hastelloy C276*						
M	Monel 400						
N	316 SST (Drain/Vent in Hastelloy C276)*						
Z	Others - Specify						
CODE	Wetted O-Rings Materials						
0	Without O-Rings						
B	Buna N						
V	Viton						
T	Teflon						
Z	Others - Specify						
CODE	Drain/Vent Position						
0	Without Drain/Vent						
U	Upper						
D	Lower						
CODE	Local Indicator						
0	Without Indicator						
1	With Digital Indicator						
CODE	Process Connections						
0	¼ - 18 NPT (Without Adapter)						
1	½ - 14 NPT (With Adapter)						
9	Remote Seal (Specify)						
Z	Others - Specify						
CODE	Electrical Connections						
0	½ - 14 NPT						
A	M20 x 1,5						
B	Pg 13,5 DIN						
Z	Others - Specify						
CODE	Zero and Span Adjustments						
1	With Local Adjustments						
CODE	Mounting Bracket for 2" Pipe or Surface Mounting						
0	Without Bracket						
1	Carbon Steel Bracket						
2	316 SST Bracket						
7	Carbon Steel bracket with 316 SST fasteners						
CODE	Optional Items **						
H1	316 SST Housing						
A1	316 SST Bolts and Nuts						
C1	Special Cleaning						
ZZ	Special Options - Specify						

LD301 - D2 | 1 | I | - | B | U | 1 | 0 | - | 0 | 1 | 2 | / | \*\* ← TYPICAL MODEL NUMBER

(1) The range can be extended up to 0.75 LRL and 1.2 URL with small degradation of accuracy.

\* Meets NACE material recommendations per MR-01-75

\*\* Leave it blank for no optional items

# ORDERING CODE

# LD301

MODEL LD301		LEVEL TRANSMITTERS										
CODE	Range											
L2	Level 1.25 to 50 kPa	5	to	200 inH <sub>2</sub> O	<b>Note:</b> The range can be extended up to 0.75 LRL and 1.2 URL with small degradation of accuracy. The Upper Range Value must be limited to the flange rating.							
L3	Level 2.08 to 250 kPa	8.33	to	1000 inH <sub>2</sub> O								
L4	Level 20.8 to 2500 kPa	3	to	360 psi								
CODE	Diaphragm Material and Fill Fluid (Low Side)											
1	316 SST	Silicone Oil			7	Tantalum					Silicone Oil	
2	316 SST	Fluorolube Oil			8	Tantalum					Fluorolube Oil	
3	Hastelloy C276	Silicone Oil*			Z	Others - Specify						
4	Hastelloy C276	Fluorolube Oil*										
5	Monel 400	Silicone Oil										
CODE	Flange, Adapter and Drain/Vent Valves Material (Low Side)											
C	Plated CS (Drain/Vent in Stainless Steel)											
I	316 SST											
H	Hastelloy C276*											
M	Monel 400											
N	316 SST (Drain/Vent in Hastelloy C276)*											
Z	Others - Specify											
CODE	Wetted O-Rings Material (Low Side)											
0	Without O-Rings (Remote Seal)											
B	Buna N											
V	Viton											
T	Teflon											
Z	Others - Specify											
CODE	Drain/Vent Position (Low Side)											
0	Without Drain/Vent											
U	Upper											
D	Lower											
<b>Note:</b> For better drain/vent operation, the side vent or drain valves are standard. If drain/vent valves are not required, use code 0.												
CODE	Local Indicator											
0	Without Indicator											
1	With Digital Indicator											
CODE	Process Connection (Low Side)											
0	¼ - 18 NPT (Without Adapter)											
1	½ - 14 NPT (With Adapter)											
9	Remote Seal (Specify)											
Z	Others - Specify											
CODE	Electrical Connection											
0	½ - 14 NPT											
A	M20 x 1,5											
B	Pg 13,5 DIN											
Z	Others - Specify											
CODE	Zero and Span Adjustments											
1	With Local Adjustment											
CODE	Process Connection (High Side)											
1	3" 150# (ANSI B16.5 RF)	9	2" 150# (ANSI B16.5 RF)									
2	3" 300# (ANSI B16.5 RF)	A	2" 300# (ANSI B16.5 RF)									
3	4" 150# (ANSI B16.5 RF)	B	2" 600# (ANSI B16.5 RF)									
4	4" 300# (ANSI B16.5 RF)	C	3" 600# (ANSI B16.5 RF)									
6	DN 80 PN 25/40	D	4" 600# (ANSI B16.5 RF)									
7	DN 100 PN 10/16	E	DN 50 PN 10/40									
8	DN 100 PN 25/40	Z	Others - Specify									
CODE	Flange Material (Level Tap)											
2	316 SST											
Z	Others - Specify											
CODE	Extension Length											
0	0 mm											
1	50 mm (2')											
2	100 mm (4')											
3	150 mm (6')											
4	200 mm (8')											
Z	Others - Specify											
CODE	Diaphragm Material (High Side)											
1	316L SST											
2	Hastelloy C276*											
3	Monel 400**											
4	Tantalum											
5	Titanium											
Z	Others - Specify											
<b>Note:</b> With 316 SST extension.												
CODE	Fill Fluid (High Side)											
1	DC200 Silicone Oil											
2	Fluorolube Oil											
3	DC704 Silicone Oil											
A	DC200/350 Silicone Oil - Food Grade											
Z	Others - Specify											
CODE	Optional Items ***											
H1	316 SST Housing											
AI	316 SST Bolts and Nuts											
C1	Special Cleaning											
ZZ	Special Options - Specify											

LD301 - L2 | 1 | I | - B | U | 1 | 0 | - 0 | 1 | - 1 | 2 | 2 | 1 | 1 | / \*\*\* ← TYPICAL MODEL NUMBER

\* Meets NACE material recommendations per MR-01-75.  
 \*\* Fluorolube fill fluid is not available for Monel Diaphragm.  
 \*\*\* Leave it blank for no optional items.

Dimensions are mm (in)

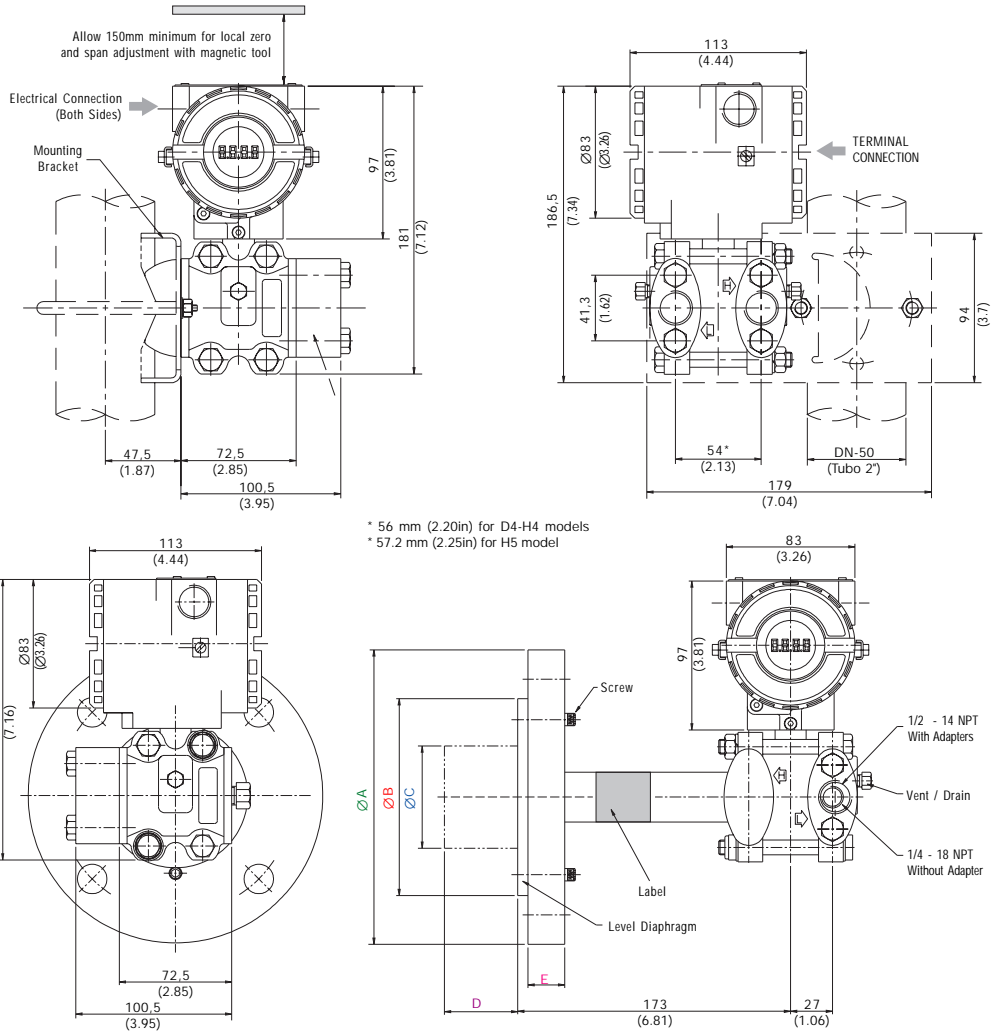

Dimensions for LD301L

Nominal Flange Size	Rating	A	B	C	E	N° Bolt Holes
2"	150 lb	152	92	48	22	4
2"	300 lb	165	92	48	23	8
2"	600 lb	165	92	48	32	8
3"	150 lb	190	127	73	24	4
3"	300 lb	210	127	73	29	8
4"	150 lb	229	157	96	24	8
4"	300 lb	254	157	96	32	8
DN50	PN10/40	165	102	48	22	4
DN80	PN25/40	200	138	73	24	8
DN100	PN10/16	220	157	96	22	8
DN100	PN25/40	235	162	96	24	8

Dimension "D" - Extension: 0, 50, 100, 150 or 200 mm