

SITRANS P measuring instruments for pressure

Transmitters for gage, absolute and differential pressure, flow and level

DS III series Technical description

Overview

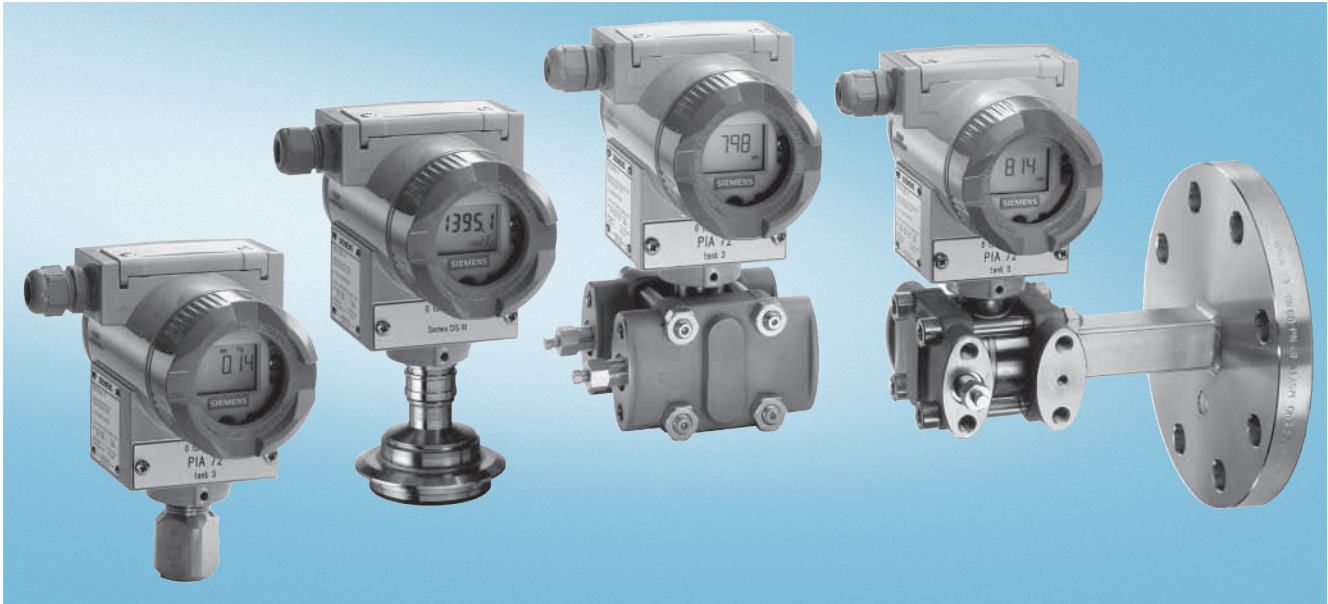

SITRANS P pressure transmitters, DS III series, are digital pressure transmitters featuring extensive user-friendliness and high accuracy. The parameterization is performed using control keys, over HART communication, PROFIBUS-PA or FOUNDATION Fieldbus interface.

Extensive functionality enables the pressure transmitter to be precisely adapted to the plant's requirements. Operation is very simple in spite of the numerous setting options.

Transmitters with type of protection "Intrinsic safety" and "Explosion-proof" may be installed within potentially explosive atmospheres (zone 1) or in zone 0. The transmitters are provided with an EC type examination certificate and comply with the corresponding harmonized European standards (ATEX).

The transmitters can be equipped with various designs of remote seals for special applications such as the measurement of highly viscous substances.

Various versions of the DS III pressure transmitters are available for measuring:

- Gage pressure
- Absolute pressure
- For differential pressure transmitters
- Filling level
- Mass level
- Volume level
- Volume flow
- Mass flow

Benefits

- High quality and long life
- High reliability even under extreme chemical and mechanical loads
- For aggressive and non-aggressive gases, vapors and liquids
- Extensive diagnosis and simulation functions
- Separate replacement of measuring cell and electronics without recalibration
- Minimum conformity error
- Small long-term drift
- Wetted parts made of high-grade materials (e.g. stainless steel, Hastelloy, gold, Monel, tantalum)

- Infinitely adjustable span from 0.01 mbar to 400 mbar for DS III with HART communication
- Nominal measuring range from 1 to 400 bar for DS III PA (PROFIBUS PA) and FF (FOUNDATION Fieldbus)
- High measuring accuracy
- Parameterization over control keys and HART communication, PROFIBUS PA communication or FOUNDATION Fieldbus interface.

Application

The pressure transmitters of the DS III series, can be used in industrial areas with extreme chemical and mechanical loads. Electromagnetic compatibility in the range 10 kHz to 1 GHz makes the DS III pressure transmitters suitable for locations with high electromagnetic emissions.

Pressure transmitters with type of protection "Intrinsic safety" and "Explosion-proof" may be installed within potentially explosive atmospheres (zone 1) or in zone 0. The pressure transmitters are provided with an EC type examination certificate and comply with the corresponding harmonized European standards (ATEX).

Pressure transmitters with the type of protection "Intrinsic safety" for use in zone 0 may be operated with power supply units of category "ia" and "ib".

The transmitters can be equipped with various designs of remote seals for special applications such as the measurement of highly viscous substances.

The pressure transmitter can be operated locally over 3 control keys or programmed externally over HART communication or over PROFIBUS PA or FOUNDATION Fieldbus interface.

SITRANS P measuring instruments for pressure

Transmitters for gage, absolute and differential pressure, flow and level

DS III series
Technical description

2

Pressure transmitter for gage pressure

- Measured variable: Gage pressure of aggressive and non-aggressive gases, vapors and liquids.
- Span (infinitely adjustable)
for DS III HART: 0.01 ... 400 bar g (0.145 ... 5802 psi g)
- Nominal measuring range
for DS III PA and FF: 1 ... 400 bar g (14.5 ... 5802 psi g)

Pressure transmitters for absolute pressure

- Measured variable: Absolute pressure of aggressive and non-aggressive gases, vapors and liquids.
- Span (infinitely adjustable)
for DS III HART: 8.3 mbar a ... 100 bar a (0.12 ... 1450 psi a)
- Nominal measuring range
for DS III PA and FF: 250 mbar a ... 100 bar a
(3.63 ... 1450 psi a)
- There are two series:
 - Gage pressure series
 - Differential pressure series

Pressure transmitters for differential pressure and flow

- Measured variables:
 - Differential pressure
 - Small positive or negative pressure
 - Flow $q \sim \sqrt{\Delta p}$ (together with a primary differential pressure device (see Chapter "Flow Meters"))
- Span (infinitely adjustable)
for DS III HART: 1 mbar ... 30 bar (0.0145 ... 435 psi)
- Nominal measuring range
for DS III PA and FF: 20 mbar ... 30 bar (0.29 ... 435 psi)

Pressure transmitters for level

- Measured variable: Level of aggressive and non-aggressive liquids in open and closed vessels.
- Span (infinitely adjustable)
for DS III HART: 25 mbar ... 5 bar (0.363 ... 72.5 psi)
- Nominal measuring range
for DS III PA and FF: 250 mbar ... 5 bar (3.63 ... 72.5 psi)
- Nominal diameter of the mounting flange
 - DN 80 or DN 100
 - 3 inch or 4 inch

In the case of level measurements in open containers, the low-pressure connection of the measuring cell remains open (measurement "compared to atmospheric").

In the case of measurements in closed containers, the lower-pressure connection has to be connected to the container in order to compensate the static pressure.

The wetted parts are made from a variety of materials, depending on the degree of corrosion resistance required.

Design

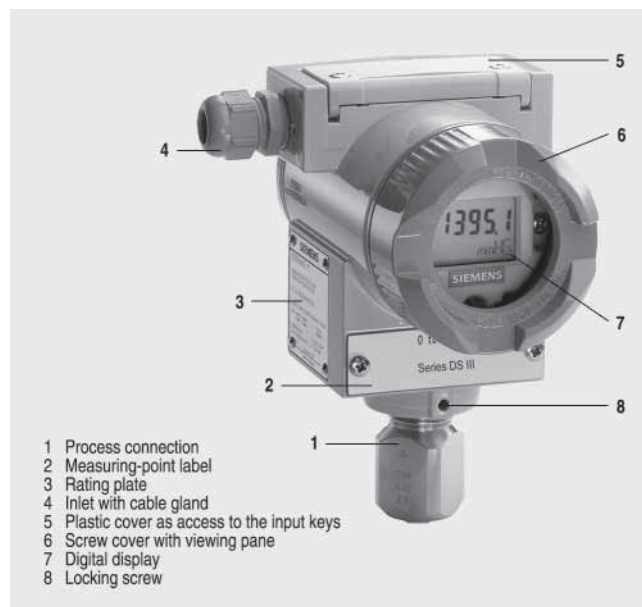

Front view

The transmitter consists of various components depending on the order. The possible versions are listed in the ordering information. The components described below are the same for all transmitters.

The rating plate (3, Figure "Front view") with the Order No. is located on the side of the housing. The specified number together with the ordering information provide details on the optional design details and on the possible measuring range (physical properties of built-in sensor element).

The approval label is located on the opposite side.

The housing is made of die-cast aluminium or stainless steel precision casting. A round cover is screwed on at the front and rear of the housing. The front cover (6) can be fitted with a viewing pane so that the measured values can be read directly on the digital display. The inlet (4) for the electrical connection is located either on the left or right side. The unused opening on the opposite side is sealed by a blanking plug. The protective earth connection is located on the rear of the housing.

The electrical connections for the power supply and screen are accessible by unscrewing the rear cover. The bottom part of the housing contains the measuring cell with process connection (1). The measuring cell is prevented from rotating by a locking screw (8). As the result of this modular design, the measuring cell and the electronics can be replaced separately from each other. The set parameter data are retained.

At the top of the housing is a plastic cover (5), which hides the input keys.

SITRANS P measuring instruments for pressure

Transmitters for gage, absolute and differential pressure, flow and level

DS III series

Technical description

Function

Mode of operation of the DS III HART electronics

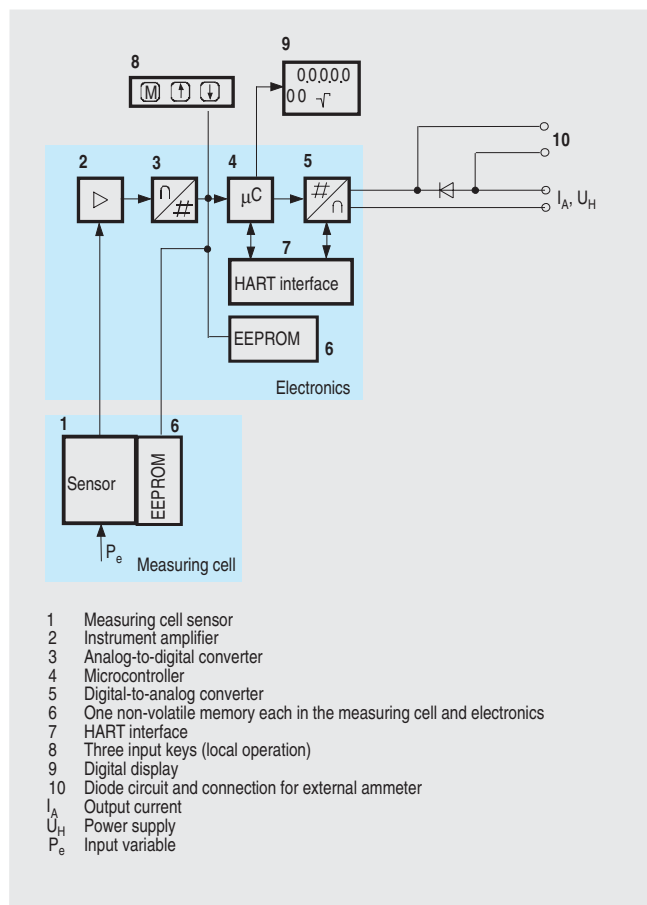

Function diagram of the electronics

The bridge output voltage created by the sensor (1, Figure "Function diagram of the electronics") is amplified by the instrument amplifier (2) and digitized in the analog-to-digital converter (3). The digital information is evaluated in a microcontroller, its linearity and temperature response corrected, and converted in a digital-to-analog converter (5) into an output current of 4 to 20 mA.

The diode circuit (10) protects against incorrect polarity.

The data specific to the measuring cell, the electronics data, and the parameter data are stored in the two non-volatile memories (6). The one memory is coupled to the measuring cell, the other to the electronics. As the result of this modular design, the electronics and the measuring cell can be replaced separately from each other.

Using the 3 input keys (8) you can parameterize the pressure transmitter directly at the point of measurement. The input keys can also be used to control the view of the results, the error messages and the operating modes on the digital display (9).

The HART modem (7) permits parameterization using a protocol according to the HART specification.

The pressure transmitters with spans ≤ 63 bar measure the input pressure compared to atmosphere, transmitters with spans ≥ 160 bar compared to vacuum.

Mode of operation of the DS III PA electronics

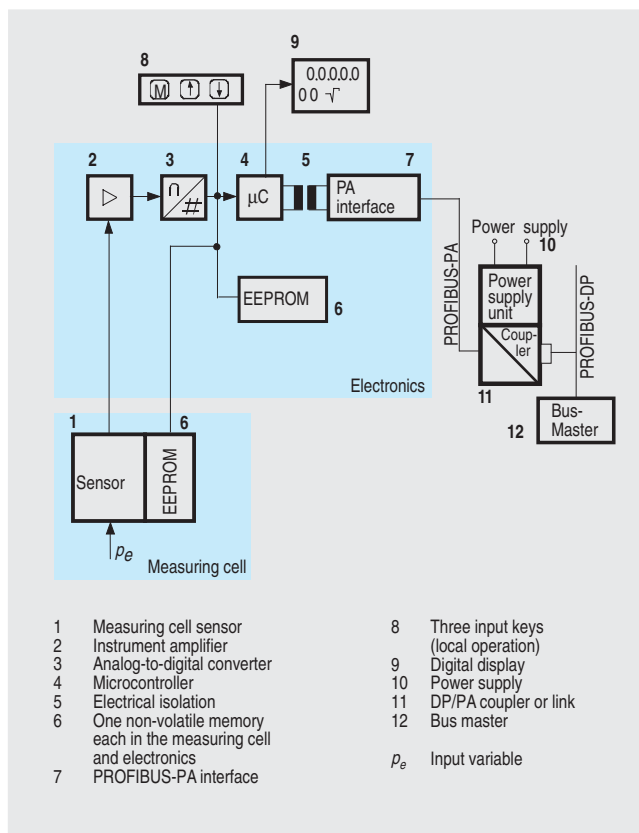

Function diagram of the electronics

The bridge output voltage created by the sensor (1, Figure "Function diagram of the electronics") is amplified by the instrument amplifier (2) and digitized in the analog-to-digital converter (3). The digital information is evaluated in the microcontroller, its linearity and temperature response corrected, and provided on the PROFIBUS PA through an electrically isolated PA interface (7).

The data specific to the measuring cell, the electronics data, and the parameter data are stored in the two non-volatile memories (6). The first memory is linked with the measuring cell, the second with the electronics. This modular design means that the electronics and the measuring cell can be replaced separately from one another.

Using the three input keys (8) you can parameterize the pressure transmitter directly at the point of measurement. The input keys can also be used to control the view of the results, the error messages and the operating modes on the digital display (9).

The results with status values and diagnostic values are transferred by cyclic data transmission on the PROFIBUS PA. Parameterization data and error messages are transferred by acyclic data transmission. Special software such as SIMATIC PDM is required for this.

SITRANS P measuring instruments for pressure

Transmitters for gage, absolute and differential pressure, flow and level

DS III series
Technical description

2

Mode of operation of the DS III FF electronics

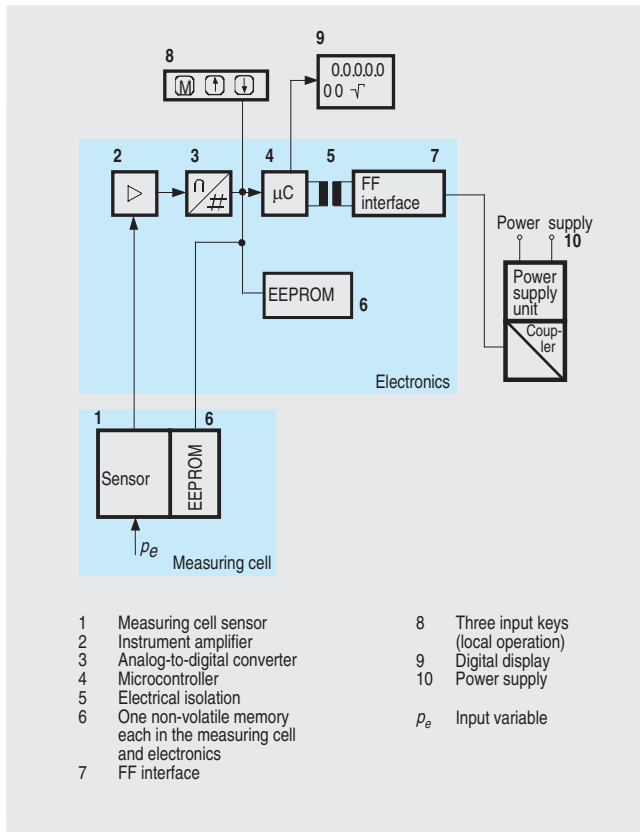

Function diagram of the electronics

The bridge output voltage created by the sensor (1, Figure "Function diagram of the electronics") is amplified by the instrument amplifier (2) and digitized in the analog-to-digital converter (3). The digital information is evaluated in the microcontroller, its linearity and temperature response corrected, and provided on the FOUNDATION Fieldbus through an electrically isolated FOUNDATION Fieldbus Interface (7).

The data specific to the measuring cell, the electronics data, and the parameter data are stored in the two non-volatile memories (6). The one memory is coupled to the measuring cell, the other to the electronics. As the result of this modular design, the electronics and the measuring cell can be replaced separately from each other.

Using the three input keys (8) you can parameterize the pressure transmitter directly at the point of measurement. The input keys can also be used to control the view of the results, the error messages and the operating modes on the digital display (9).

The results with status values and diagnostic values are transferred by cyclic data transmission on the FOUNDATION Fieldbus. Parameterization data and error messages are transferred by acyclic data transmission. Special software such as National Instruments Configurator is required for this.

Mode of operation of the measuring cells

Measuring cell for gage pressure

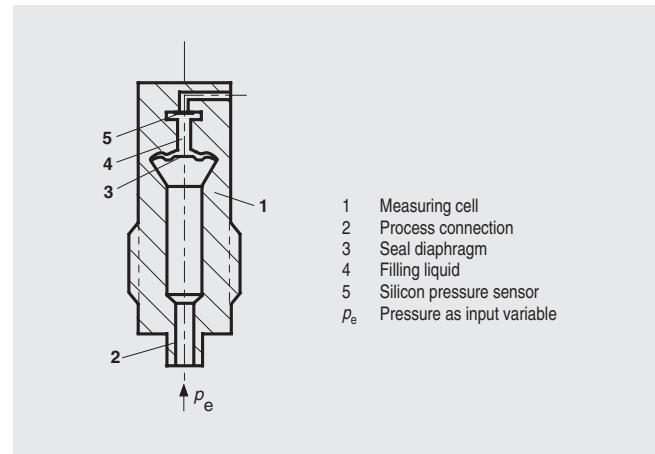

Measuring cell for gage pressure, function diagram

The pressure p_e is applied through the process connection (2, Figure "Measuring cell for gage pressure, function diagram") to the measuring cell (1). This pressure is subsequently transmitted further through the seal diaphragm (3) and the filling liquid (4) to the silicon pressure sensor (5) whose measuring diaphragm is then flexed. This changes the resistance of the four piezo-resistors fitted in the diaphragm in a bridge circuit. This change in resistance results in a bridge output voltage proportional to the input pressure.

Measuring cell for gage pressure, with front-flush diaphragm for paper industry

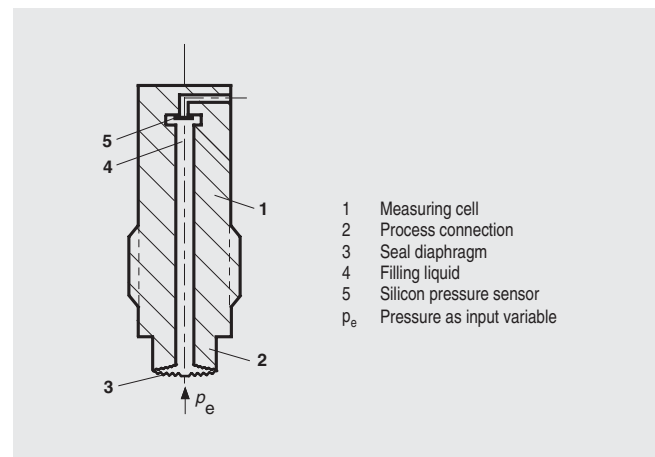

Measuring cell for gage pressure, with front-flush diaphragm for paper industry, function diagram

The pressure p_e is applied through the process connection (2, Figure "Measuring cell for gage pressure, with front-flush diaphragm for paper industry, function diagram") to the measuring cell (1). This pressure is subsequently transmitted further through the seal diaphragm (3) and the filling liquid (4) to the silicon pressure sensor (5) whose measuring diaphragm is then flexed. This changes the resistance of the four piezo-resistors fitted in the diaphragm in a bridge circuit. This change in resistance results in a bridge output voltage proportional to the input pressure.

SITRANS P measuring instruments for pressure

Transmitters for gage, absolute and differential pressure, flow and level

DS III series Technical description

Measuring cell for absolute pressure from gage pressure series

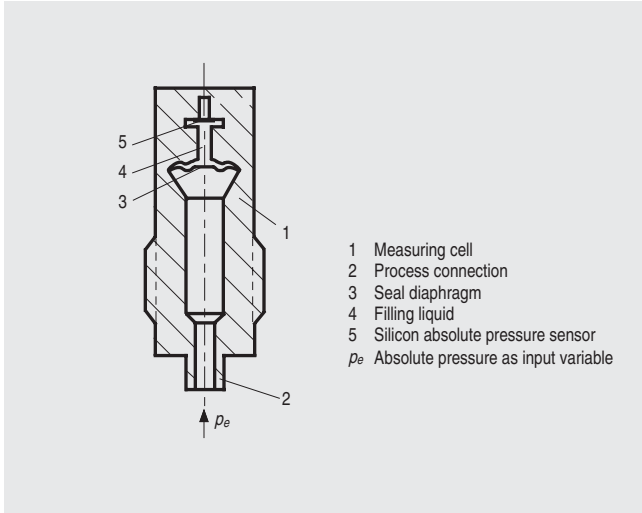

Measuring cell for absolute pressure from the pressure series, function diagram

The absolute pressure p_e is transmitted through the seal diaphragm (3, Figure "Measuring cell for absolute pressure from the gage pressure series, function diagram") and the filling liquid (4) to the silicon absolute pressure sensor (5) whose measuring diaphragm is then flexed. This changes the resistance of the four piezo-resistors fitted in the diaphragm in a bridge circuit. This change in resistance results in a bridge output voltage proportional to the input pressure.

Measuring cell for absolute pressure from differential pressure series

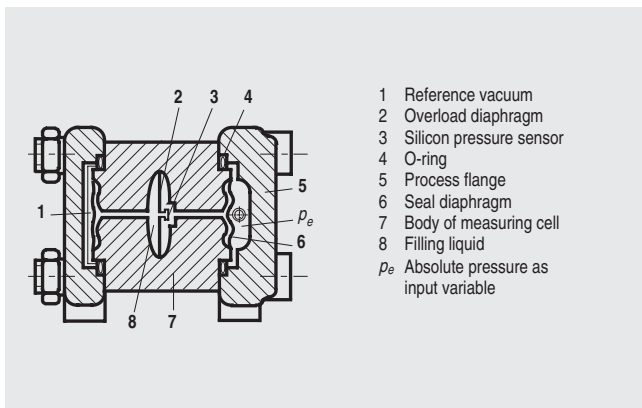

Measuring cell for absolute pressure from differential pressure series, function diagram

The input pressure p_e is transmitted through the seal diaphragm (6, Figure "Measuring cell for absolute pressure from differential pressure series, function diagram") and the filling liquid (8) to the silicon pressure sensor (3).

The difference in pressure between the input pressure p_e and the reference vacuum (1) on the low-pressure side of the measuring cell flexes the measuring diaphragm. The resistance of the four piezo-resistors fitted in the diaphragm in a bridge circuit thus changes. This change in resistance results in a bridge output voltage proportional to the absolute pressure.

An overload diaphragm is installed to provide protection from overloads. If the measuring limits are exceeded, the overload diaphragm (2) is flexed until the seal diaphragm rests on the body of the measuring cell (7), thus protecting the silicon pressure sensor from overloads.

Measuring cell for differential pressure and flow

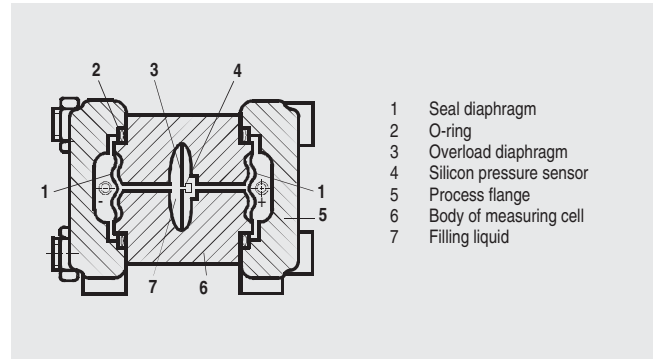

Measuring cell for differential pressure and flow, function diagram

The differential pressure is transmitted through the seal diaphragms (1, Figure "Measuring cell for differential pressure and flow, function diagram") and the filling liquid (7) to the silicon pressure sensor (4).

The measuring diaphragm is flexed by the applied differential pressure. This changes the resistance of the four piezo-resistors fitted in the diaphragm in a bridge circuit. This change in resistance results in a bridge output voltage proportional to the absolute pressure.

An overload diaphragm is installed to provide protection from overloads. If the measuring limits are exceeded, the overload diaphragm (2) is flexed until the seal diaphragm rests on the body of the measuring cell (7), thus protecting the silicon pressure sensor from overloads.

Measuring cell for level

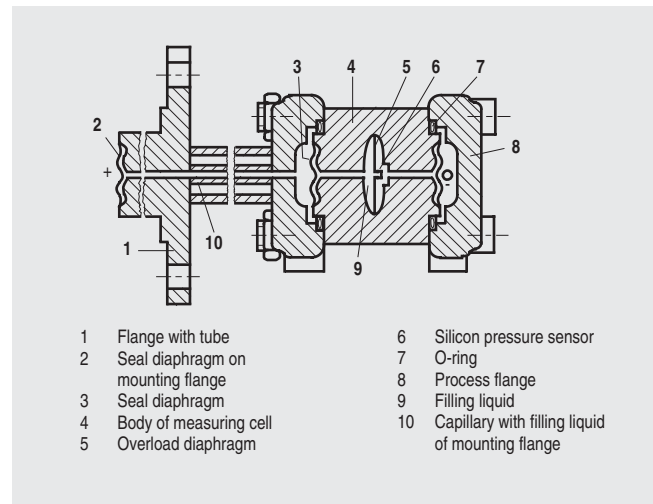

Measuring cell for level, function diagram

The input pressure (hydrostatic pressure) acts hydraulically on the measuring cell through the seal diaphragm on the mounting flange (2, Figure "Measuring cell for level, function diagram"). This differential pressure is subsequently transmitted further through the measuring cell (3) and the filling liquid (9) to the silicon pressure sensor (6) whose measuring diaphragm is then flexed.

This changes the resistance of the four piezo-resistors fitted in the diaphragm in a bridge circuit.

This change in resistance results in a bridge output voltage proportional to the differential pressure.

An overload diaphragm is installed to provide protection from overloads. If the measuring limits are exceeded, the overload diaphragm (2) is flexed until the seal diaphragm rests on the body of the measuring cell (7), thus protecting the silicon pressure sensor from overloads.

SITRANS P measuring instruments for pressure

Transmitters for gage, absolute and differential pressure, flow and level

DS III series
Technical description

2

Parameterization DS III

Depending on the version, there are a range of options for parameterizing the pressure transmitter and for setting or scanning the parameters.

Parameterization using the input keys (local operation)

With the input keys you can easily set the most important parameters without any additional equipment.

Parameterization using HART communication

Parameterization using HART communication is performed with a HART communicator or a PC.

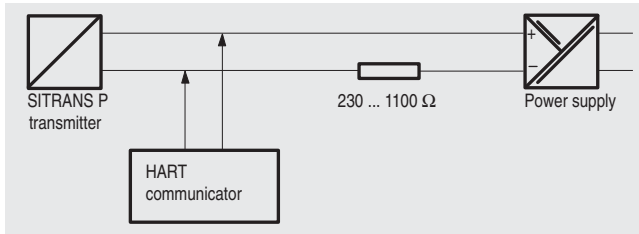

Communication between a HART communicator and a pressure transm.

When parameterizing with the HART communicator, the connection is made directly to the 2-wire system.

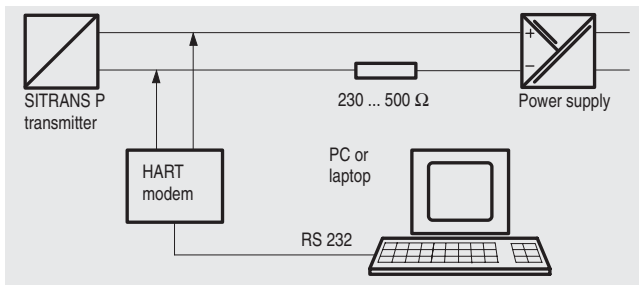

HART communication between a PC communicator and a pressure transmitter

When parameterizing with a PC, the connection is made through a HART modem.

The signals needed for communication in conformity with the HART 5.x or 6.x protocols are superimposed on the output current using the Frequency Shift Keying (FSK) method.

Adjustable parameters, DS III HART

Parameters	Input keys (DS III HART)	HART communication
Start of scale	x	x
Full-scale value	x	x
Electrical damping	x	x
Start-of-scale value without application of a pressure ("Blind setting")	x	x
Full-scale value without application of a pressure ("Blind setting")	x	x
Zero adjustment	x	x
Current transmitter	x	x
Fault current	x	x
Disabling of keys, write protection	x	x ¹⁾
Type of dimension and actual dimension	x	x
Characteristic (linear / square-rooted)	x ²⁾	x ²⁾
Input of characteristic		x
Freely-programmable LCD		x
Diagnostics functions		x

1) Cancel apart from write protection

2) Only differential pressure

Diagnostic functions for DS III HART

- Zero correction display
- Event counter
- Limit transmitter
- Saturation alarm
- Slave pointer
- Simulation functions
- Maintenance timer

Available physical units of display for DS III HART

Table style: Technical specifications 2

Physical variable	Physical dimensions
Pressure (setting can also be made in the factory)	Pa, MPa, kPa, bar, mbar, torr, atm, psi, g/cm ² , kg/cm ² , inH ₂ O, inH ₂ O (4 °C), mmH ₂ O, ftH ₂ O (20 °C), inHg, mmHg
Level (height data)	m, cm, mm, ft, in
Volume	m ³ , dm ³ , hl, yd ³ , ft ³ , in ³ , US gallon, Imp. gallon, bushel, barrel, barrel liquid
Mass	g, kg, t, lb, Ston, Lton, oz
Volume flow	m ³ /d, m ³ /h, m ³ /s, l/min, l/s, ft ³ /d, ft ³ /min, ft ³ /s, US gallon/min, US gallon/s
Mass flow	t/d, t/h, t/min, kg/d, kg/h, kg/min, kg/s, g/d, g/h, g/min, g/s, lb/d, lb/h, lb/min, lb/s, LTon/d, LTon/h, STon/d, STon/h, STon/min
Temperature	K, °C, °F, °R
Miscellaneous	%, mA

Parameterization through PROFIBUS PA interface

Fully digital communication through PROFIBUS PA, profile 3.0, is particularly user-friendly. The PROFIBUS puts the DS III PA in connection with a process control system, e.g. SIMATIC PSC 7. Communication is possible even in a potentially explosive environment.

For parameterization through PROFIBUS you need suitable software, e.g. SIMATIC PDM (Process Device Manager).

Parameterization through FOUNDATION Fieldbus Interface

Fully digital communication through FOUNDATION Fieldbus is particularly user-friendly. Through the FOUNDATION Fieldbus the DS III FF is connected to a process control system. Communication is possible even in a potentially explosive environment.

For parameterization through the FOUNDATION Fieldbus you need suitable software, e.g. National Instruments Configurator.

Adjustable parameters for DS III PA and FF

Parameters	Input keys (DS III HART)	PROFIBUS PA and FOUNDATION Fieldbus interface
Electrical damping	x	x
Zero adjustment (correction of position)	x	x
Key and/or function disabling	x	x
Source of measured-value display	x	x
Physical dimension of display	x	x
Position of decimal point	x	x
Bus address	x	x
Adjustment of characteristic	x	x
Input of characteristic		x
Freely-programmable LCD		x
Diagnostics functions		x

SITRANS P measuring instruments for pressure

Transmitters for gage, absolute and differential pressure, flow and level

DS III series Technical description

Diagnostic functions for DS III PA and FF

- Event counter
- Slave pointer
- Maintenance timer
- Simulation functions
- Display of zero correction
- Limit transmitter
- Saturation alarm

Physical dimensions available for the display

Physical variable	Physical dimensions
Pressure (setting can also be made in the factory)	MPa, kPa, Pa, bar, mbar, torr, atm, psi, g/cm ² , kg/cm ² , mmH ₂ O, mmH ₂ O (4 °C), inH ₂ O, inH ₂ O (4 °C), ftH ₂ O (20 °C), mmHg, inHg
Level (height data)	m, cm, mm, ft, in, yd
Volume	m ³ , dm ³ , hl, yd ³ , ft ³ , in ³ , US gallon, Imp. gallon, bushel, barrel, barrel liquid
Volume flow	m ³ /s, m ³ /min, m ³ /h, m ³ /d, l/s, l/min, l/h, l/d, Ml/d, ft ³ /s, ft ³ /min, ft ³ /h, ft ³ /d, US gallon/s, US gallon/min, US gallon/h, US gallon/d, bbl/s, bbl/min, bbl/h, bbl/d
Mass flow	g/s, g/min, g/h, g/d, kg/s, kg/min, kg/h, kg/d, t/s, t/min, t/h, t/d, lb/s, lb/min, lb/h, lb/d, STon/s, STon/min, STon/h, STon/d, LTon/s, LTon/min, LTon/h, LTon/d
Total mass flow	t, kg, g, lb, oz, LTon, STon
Temperature	K, °C, °F, °R
Miscellaneous	%

SITRANS P measuring instruments for pressure

Transmitters for gage, absolute and differential pressure, flow and level

DS III series
for gage pressure

2

Technical specifications

SITRANS P, DS III series for gage pressure

	HART	PROFIBUS PA or FOUNDATION Fieldbus																												
Input																														
Measured variable	Gage pressure																													
Spans (infinitely adjustable) or nominal measuring range and max. permissible test pressure	<table border="1"> <thead> <tr> <th>Span</th> <th>Max. perm. test pressure</th> </tr> </thead> <tbody> <tr> <td>0.01 ... 1 bar g (0.145 ... 14.5 psi g)</td> <td>6 bar g (87 psi g)</td> </tr> <tr> <td>0.04 ... 4 bar g (0.58 ... 58 psi g)</td> <td>10 bar g (145 psi g)</td> </tr> <tr> <td>0.16 ... 16 bar g (2.23 ... 232 psi g)</td> <td>32 bar g (464 psi g)</td> </tr> <tr> <td>0.6 ... 63 bar g (9.14 ... 914 psi g)</td> <td>100 bar g (1450 psi g)</td> </tr> <tr> <td>1.6 ... 160 bar g (23.2 ... 2320 psi g)</td> <td>250 bar g (3626 psi g)</td> </tr> <tr> <td>4.0 ... 400 bar g (58 ... 5802 psi g)</td> <td>600 bar g (8700 psi g)</td> </tr> </tbody> </table>	Span	Max. perm. test pressure	0.01 ... 1 bar g (0.145 ... 14.5 psi g)	6 bar g (87 psi g)	0.04 ... 4 bar g (0.58 ... 58 psi g)	10 bar g (145 psi g)	0.16 ... 16 bar g (2.23 ... 232 psi g)	32 bar g (464 psi g)	0.6 ... 63 bar g (9.14 ... 914 psi g)	100 bar g (1450 psi g)	1.6 ... 160 bar g (23.2 ... 2320 psi g)	250 bar g (3626 psi g)	4.0 ... 400 bar g (58 ... 5802 psi g)	600 bar g (8700 psi g)	<table border="1"> <thead> <tr> <th>Nominal measuring range</th> <th>Max. perm. test pressure</th> </tr> </thead> <tbody> <tr> <td>1 bar g (14.5 psi g)</td> <td>6 bar g (87 psi g)</td> </tr> <tr> <td>4 bar g (58 psi g)</td> <td>10 bar g (145 psi g)</td> </tr> <tr> <td>16 bar g (232 psi g)</td> <td>32 bar g (464 psi g)</td> </tr> <tr> <td>63 bar g (914 psi g)</td> <td>100 bar g (1450 psi g)</td> </tr> <tr> <td>160 bar g (2320 psi g)</td> <td>250 bar g (3626 psi g)</td> </tr> <tr> <td>400 bar g (5802 psi g)</td> <td>600 bar g (8700 psi g)</td> </tr> </tbody> </table>	Nominal measuring range	Max. perm. test pressure	1 bar g (14.5 psi g)	6 bar g (87 psi g)	4 bar g (58 psi g)	10 bar g (145 psi g)	16 bar g (232 psi g)	32 bar g (464 psi g)	63 bar g (914 psi g)	100 bar g (1450 psi g)	160 bar g (2320 psi g)	250 bar g (3626 psi g)	400 bar g (5802 psi g)	600 bar g (8700 psi g)
Span	Max. perm. test pressure																													
0.01 ... 1 bar g (0.145 ... 14.5 psi g)	6 bar g (87 psi g)																													
0.04 ... 4 bar g (0.58 ... 58 psi g)	10 bar g (145 psi g)																													
0.16 ... 16 bar g (2.23 ... 232 psi g)	32 bar g (464 psi g)																													
0.6 ... 63 bar g (9.14 ... 914 psi g)	100 bar g (1450 psi g)																													
1.6 ... 160 bar g (23.2 ... 2320 psi g)	250 bar g (3626 psi g)																													
4.0 ... 400 bar g (58 ... 5802 psi g)	600 bar g (8700 psi g)																													
Nominal measuring range	Max. perm. test pressure																													
1 bar g (14.5 psi g)	6 bar g (87 psi g)																													
4 bar g (58 psi g)	10 bar g (145 psi g)																													
16 bar g (232 psi g)	32 bar g (464 psi g)																													
63 bar g (914 psi g)	100 bar g (1450 psi g)																													
160 bar g (2320 psi g)	250 bar g (3626 psi g)																													
400 bar g (5802 psi g)	600 bar g (8700 psi g)																													
Lower measuring limit	30 mbar a (0.435 psi a)																													
<ul style="list-style-type: none"> Measuring cell with silicone oil filling Measuring cell with inert filling liquid 	30 mbar a (0.435 psi a)																													
Upper measuring limit	100% of max. span (max. 160 bar g (2320 psi g) with oxygen measurement and inert liquid)																													
Output																														
Output signal	4 ... 20 mA	Digital PROFIBUS PA or FOUNDATION Fieldbus signal																												
<ul style="list-style-type: none"> Lower limit (infinitely adjustable) Upper limit (infinitely adjustable) 	3.55 mA, factory preset to 3.84 mA 23 mA, factory preset to 20.5 mA or optionally set to 22.0 mA	-																												
Load																														
<ul style="list-style-type: none"> Without HART communication With HART communication 	$R_B \leq (U_H - 10.5 \text{ V})/0.023 \text{ A}$ in Ω , U_H : Power supply in V $R_B = 230 \dots 500 \Omega$ (SIMATIC PDM) or $R_B = 230 \dots 1100 \Omega$ (HART Communicator)	-																												
Physical bus	-	IEC 61158-2																												
With polarity reversal protection	-	Yes																												
Accuracy	To EN 60770-1																													
Reference conditions	Increasing characteristic, start-of-scale value 0 bar, stainless steel seal diaphragm, silicone oil filling, room temperature 25 °C (77 °F) r: Span ratio (r = max. span/set span)																													
Error in measurement and fixed-point setting (including hysteresis and repeatability)																														
<ul style="list-style-type: none"> Linear characteristic - $r \leq 10$ - $10 < r \leq 30$ - $30 < r \leq 100$ 	$\leq (0.0029 \cdot r + 0.071)\%$ $\leq (0.0045 \cdot r + 0.071)\%$ $\leq (0.005 \cdot r + 0.05)\%$	$\leq 0,075\%$																												
Long-term drift (temperature change $\pm 30 \text{ }^\circ\text{C}$ ($\pm 54 \text{ }^\circ\text{F}$))	$\leq (0.25 \cdot r)\%$ every 5 years	$\leq 0.25\%$ every 5 years																												
Influence of ambient temperature																														
<ul style="list-style-type: none"> at $-10 \dots +60 \text{ }^\circ\text{C}$ ($14 \dots 140 \text{ }^\circ\text{F}$) at $-40 \dots -10 \text{ }^\circ\text{C}$ and $+60 \dots +85 \text{ }^\circ\text{C}$ ($-40 \dots +14 \text{ }^\circ\text{F}$ and $140 \dots 185 \text{ }^\circ\text{F}$) 	$\leq (0.08 \cdot r + 0.1)\%$ $\leq (0.1 \cdot r + 0.15)\%/10 \text{ K}$	$\leq 0,3\%$ $\leq 0.25\%/10 \text{ K}$																												
Measured Value Resolution	-	$3 \cdot 10^{-5}$ of nominal measuring range																												

SITRANS P measuring instruments for pressure

Transmitters for gage, absolute and differential pressure, flow and level

DS III series for gage pressure

2

SITRANS P, DS III series for gage pressure

	HART	PROFIBUS PA or FOUNDATION Fieldbus
Rated operating conditions		
Degree of protection (to EN 60529)	IP65	
Process temperature		
• Measuring cell with silicone oil filling	-40 ... +100 °C (-40 ... +212 °F)	
• Measuring cell with inert filling liquid	-20 ... +100 °C (-4 ... +212 °F)	
• In conjunction with dust explosion protection	-20 ... +60 °C (-4 ... +140 °F)	
Ambient conditions		
• Ambient temperature		
- Digital indicators	-30 ... +85 °C (-22 ... +185 °F)	
• Storage temperature	-50 ... +85 °C (-58 ... +185 °F)	
• Climatic class		
- Condensation	Permissible	
• Electromagnetic compatibility		
- Emitted interference and interference immunity	To EN 61326 and NAMUR NE 21	
Design		
Weight (without options)	≈ 1.5 kg (≈ 3.3 lb)	
Housing material	Poor in copper die-cast aluminium, GD-AISI12 or stainless steel precision casting, mat. No. 1.4408	
Wetted parts materials		
• Connection shank	Stainless steel, mat. No. 1.4404/316L or Hastelloy C4, mat. No. 2.4610	
• Oval flange	Stainless steel, mat. No. 1.4404/316L	
• Seal diaphragm	Stainless steel, mat. No. 1.4404/316L or Hastelloy C276, mat. No. 2.4819	
Measuring cell filling	Silicone oil or inert filling liquid (max. 160 bar (2320 psi g) with oxygen measurement)	
Process connection	Connection shank G $\frac{1}{2}$ A to DIN EN 837-1, female thread $\frac{1}{2}$ -14 NPT or oval flange (PN 160 (MWP 2320 psi g)) to DIN 19213 with mounting thread M10 or $\frac{7}{16}$ -20 UNF to EN 61518	
Power supply U_H		
Terminal voltage on transmitter	10.5 ... 45 V DC 10.5 ... 30 V DC in intrinsically-safe mode	Supplied through bus -
Separate 24 V power supply necessary	-	No
Bus voltage		
• Not Ex	-	9 ...32 V
• With intrinsically-safe operation	-	9 ...24 V
Current consumption		
• Basic current (max.)	-	12.5 mA
• Startup current \leq basic current	-	Yes
• Max. current in event of fault	-	15.5 mA
Fault disconnection electronics (FDE) available	-	Yes

SITRANS P measuring instruments for pressure

Transmitters for gage, absolute and differential pressure, flow and level

DS III series
for gage pressure

2

SITRANS P, DS III series for gage pressure

	HART	PROFIBUS PA or FOUNDATION Fieldbus
Certificate and approvals		
Classification according to pressure equipment directive (DRGL 97/23/EC)	For gases of fluid group 1 and liquids of fluid group 1; complies with requirements of Article 3, paragraph 3 (sound engineering practice)	
Explosion protection		
• Intrinsic safety "i"	PTB 99 ATEX 2122	
- Identification	Ex II 1/2 G EEx ia/ib IIB/IIC T6	
- Permissible ambient temperature	-40 ... +85 °C (-40 ... +185 °F) temperature class T4; -40 ... +70 °C (-40 ... +158 °F) temperature class T5; -40 ... +60 °C (-40 ... +140 °F) temperature class T6	
- Connection	To certified intrinsically-safe circuits with maximum values: $U_i = 30 \text{ V}$, $I_i = 100 \text{ mA}$, $P_i = 750 \text{ mW}$; $R_i = 300 \Omega$	FISCO supply unit: $U_o = 17.5 \text{ V}$, $I_o = 380 \text{ mA}$, $P_o = 5.32 \text{ W}$ Linear barrier: $U_o = 24 \text{ V}$, $I_o = 250 \text{ mA}$, $P_o = 1.2 \text{ W}$
- Effective internal inductance/capacitance	$L_i = 0.4 \text{ mH}$, $C_i = 6 \text{ nF}$	$L_i = 7 \mu\text{H}$, $C_i = 1.1 \text{ nF}$
• Explosion-proof "d"	PTB 99 ATEX 1160	
- Identification	Ex II 1/2 G EEx d IIC T4/T6	
- Permissible ambient temperature	-40 ... +85 °C (-40 ... +185 °F) temperature class T4; -40 ... +60 °C (-40 ... +140 °F) temperature class T6	
- Connection	To circuits with values: $U_H = 10.5 \dots 45 \text{ V DC}$	To circuits with values: $U_H = 9 \dots 32 \text{ V DC}$
• Dust explosion protection for zone 20	PTB 01 ATEX 2055	
- Identification	Ex II 1 D IP65 T 120 °C Ex II 1/2 D IP65 T 120 °C	
- Permissible ambient temperature	-40 ... +85 °C (-40 ... +185 °F)	
- Max. surface temperature	120 °C (248 °F)	
- Connection	To certified intrinsically-safe circuits with maximum values: $U_i = 30 \text{ V}$, $I_i = 100 \text{ mA}$, $P_i = 750 \text{ mW}$, $R_i = 300 \Omega$	FISCO supply unit: $U_o = 17.5 \text{ V}$, $I_o = 380 \text{ mA}$, $P_o = 5.32 \text{ W}$ Linear barrier: $U_o = 24 \text{ V}$, $I_o = 250 \text{ mA}$, $P_o = 1.2 \text{ W}$
- Effective internal inductance/capacitance	$L_i = 0.4 \text{ mH}$, $C_i = 6 \text{ nF}$	$L_i = 7 \mu\text{H}$, $C_i = 1.1 \text{ nF}$
• Dust explosion protection for zone 21/22	PTB 01 ATEX 2055	
- Identification	Ex II 2 D IP65 T 120 °C	
- Connection	To circuits with values: $U_H = 10.5 \dots 45 \text{ V DC}$; $P_{\text{max}} = 1.2 \text{ W}$	To circuits with values: $U_H = 9 \dots 32 \text{ V DC}$; $P_{\text{max}} = 1.2 \text{ W}$
• Type of protection "n" (zone 2)	TÜV 01 ATEX 1696 X	Planned
- Identification	Ex II 3 G EEx nA L IIC T4/T5/T6	-
• Explosion protection to FM	Certificate of Compliance 3008490	
- Identification (XP/DIP) or (IS); (NI)	CL I, DIV 1, GP ABCD T4...T6; CL II, DIV 1, GP EFG; CL III; CL I, ZN 0/1 AEx ia IIC T4...T6; CL I, DIV 2, GP ABCD T4...T6; CL II, DIV 2, GP FG; CL III	
• Explosion protection to CSA	Certificate of Compliance 1153651	
- Identification (XP/DIP) or (IS)	CL I, DIV 1, GP ABCD T4...T6; CL II, DIV 1, GP EFG; CL III; Ex ia IIC T4...T6; CL I, DIV 2, GP ABCD T4...T6; CL II, DIV 2, GP FG; CL III	

SITRANS P measuring instruments for pressure

Transmitters for gage, absolute and differential pressure, flow and level

DS III series for gage pressure

2

HART communication

HART communication	230 ... 1100 Ω
Protocol	HART Version 5.x
Software for computer	SIMATIC PDM

PROFIBUS PA communication

Simultaneous communication with master class 2 (max.)	4
The address can be set using	Configuration tool or local operation (standard setting address 126)
Cyclic data usage	
• Output byte	5 (one measuring value) or 10 (two measuring values)
• Input byte	0, 1, or 2 (register operating mode and reset function for metering)
Internal preprocessing	
Device profile	PROFIBUS PA Profile for Process Control Devices Version 3.0, Class B
Function blocks	2
• Analog input	
- Adaptation to customer-specific process variables	Yes, linearly rising or falling characteristic
- Electrical damping T_{63} , adjustable	0 ... 100 s
- Simulation function	Input /Output
- Failure mode	Can be parameterized (last good value, substitute value, incorrect value)
- Limit monitoring	Yes, one upper and lower warning limit and one alarm limit respectively
• Register (totalizer)	Can be reset, preset, optional direction of counting, simulation function of register output
- Failure mode	Can be parameterized (summation with last good value, continuous summation, summation with incorrect value)
- Limit monitoring	One upper and lower warning limit and one alarm limit respectively
• Physical block	1
Transducer blocks	2
• Pressure transducer block	
- Can be calibrated by applying two pressures	Yes
- Monitoring of sensor limits	Yes
- Specification of a container characteristic with	Max. 30 nodes
- Square-rooted characteristic for flow measurement	Yes
- Gradual volume suppression and implementation point of square-root extraction	Parameterizable
- Simulation function for measured pressure value and sensor temperature	Constant value or over parameterizable ramp function

Communication FOUNDATION Fieldbus

Function blocks	3 function blocks analog input, 1 function block PID
• Analog input	
- Adaptation to customer-specific process variables	Yes, linearly rising or falling characteristic
- Electrical damping T_{63} , adjustable	0 ... 100 s
- Simulation function	Output/input (can be locked within the device with a bridge)
- Failure mode	Can be parameterized (last good value, substitute value, incorrect value)
- Limit monitoring	Yes, one upper and lower warning limit and one alarm limit respectively
- Square-rooted characteristic for flow measurement	Yes
• PID	Standard FF function block
• Physical block	1 Resource block
Transducer blocks	1 transducer block Pressure with calibration, 1 transducer block LCD
• Pressure transducer block	
- Can be calibrated by applying two pressures	Yes
- Monitoring of sensor limits	Yes
- Simulation function: Measured pressure value, sensor temperature and electronics temperature	Constant value or over parameterizable ramp function

SITRANS P measuring instruments for pressure

Transmitters for gage, absolute and differential pressure, flow and level

DS III series
for gage pressure

2

Selection and Ordering data		Order No.
SITRANS P pressure transmitters for gage pressure, series DS III HART		7MF4033-
Measuring cell filling	Measuring cell cleaning	
Silicone oil	Standard	▶ 1
Inert liquid ¹⁾	Grease-free	▶ 3
Span		
0.01 ... 1 bar g	(0.15 ... 14.5 psi g)	▶ B
0.04 ... 4 bar g	(0.58 ... 58 psi g)	▶ C
0.16 ... 16 bar g	(2.32 ... 232 psi g)	▶ D
0.63 ... 63 bar g	(9.14 ... 914 psi g)	▶ E
1.6 ... 160 bar g	(23.2 ... 2320 psi g)	▶ F
4.0 ... 400 bar g	(58.0 ... 5802 psi g)	▶ G
Wetted parts materials		
Seal diaphragm	Process connection	
Stainless steel	Stainless steel	▶ A
Hastelloy	Stainless steel	F) B
Hastelloy	Hastelloy	F) C
Version as diaphragm seal ^{2) 3)}		Y
Process connection		
• Connection shank G½A to EN 837-1		▶ 0
• Female thread ½-14 NPT		▶ 1
• Oval flange made of stainless steel		
- Mounting thread 7/16-20 UNF to EN 61518		▶ 2
- Mounting thread M10 to DIN 19213		▶ 3
- Mounting thread M12 to DIN 19213		▶ 4
• Male thread M20 x 1,5		▶ 5
• Male thread ½-14 NPT		▶ 6
Non-wetted parts materials		
• Housing made of die-cast aluminium		▶ 0
• Housing stainless steel precision casting ⁴⁾		▶ 3
Version		
• Standard version		▶ 1
• International version, English label inscriptions, documentation in 5 languages on CD		▶ 2
Explosion protection		
• Without		A
• With ATEX, Type of protection:		
- "Intrinsic safety (EEx ia)"		B
- "Explosion-proof (EEx d)" ⁵⁾		F) D
- "Intrinsic safety and explosion-proof enclosure F (EEx ia + EEx d)" ⁶⁾		P
- "Ex nA/nL (zone 2)"		E
- "Intrinsic safety, explosion-proof enclosure and dust explosion protection (EEx ia + EEx d + Zone 1D/2D)" ⁶⁾		▶ R
• With FM + CSA, Type of protection:		
- "Intrinsic safety and explosion-proof (is + xp)" ⁵⁾		F) NC
Electrical connection / cable entry		
• Screwed gland Pg 13.5 (adapter) ⁷⁾		A
• Screwed gland M20x1.5		▶ B
• Screwed gland ½-14 NPT		C
• Han 7D plug (plastic housing) incl. mating connector ⁷⁾		F) D
• M12 connector (metall) ⁸⁾		F) F
Display		
• Without (digital indicator hidden, setting: mA)		▶ 1
• With visible digital indicator, setting: mA		▶ 6
• with customer-specific digital indicator (setting as specified, Order code "Y21" or "Y22" required)		▶ 7

▶ Available ex stock

Power supply units see "SITRANS I power supply units and isolation amplifiers".

Selection and Ordering data	Order No.
SITRANS P pressure transmitters for gage pressure, series DS III HART	7MF4033-

Power supply units see "SITRANS I power supply units and isolation amplifiers".

Factory-mounting of shut-off valves and valve manifolds see page 2/133.

Included in delivery of the device:

- Brief instructions (Leporello)
- CD-ROM with detailed documentation

- 1) For oxygen application, add Order code E10.
- 2) When the manufacturer's certificate M (calibration certificate) has to be ordered for transmitters with diaphragm seals, it is recommended only to order this certificate exclusively with the diaphragm seals. The measuring accuracy of the total combination is certified here.
- 3) When the acceptance test certificate 3.1 for transmitters with direct-connected diaphragm seals is ordered, this certificate must also be ordered with the corresponding seals.
- 4) Not together with Electrical connection „Screwed gland Pg 13.5" and „Han7D plug".
- 5) Without cable gland, with blanking plug
- 6) With enclosed cable gland EEx ia and blanking plug
- 7) Not together with type of protection "Explosion-proof" and type of protection "Ex nA".
- 8) Cannot be used together with the following types of protection: "Explosion-proof" and "Intrinsic safety and explosion-proof"

F) Subject to export regulations AL: 9I999, ECCN: N.

SITRANS P measuring instruments for pressure

Transmitters for gage, absolute and differential pressure, flow and level

DS III series for gage pressure

2

Selection and Ordering data		Order No.	
SITRANS P pressure transmitters for gage pressure			
DS III PA (PROFIBUS PA) series		7MF4034-	
DS III FF series (FOUNDATION Fieldbus)		7MF4035-	
		- - - - -	
Measuring cell filling	Measuring cell cleaning		
Silicone oil	Standard	1	
Inert liquid ¹⁾	Grease-free	3	
Nominal measuring range			
1 bar g	(14.5 psi g)	F)	B
4 bar g	(58 psi g)	F)	C
16 bar g	(232 psi g)		D
63 bar g	(914 psi g)		E
160 bar g	(2320 psi g)		F
400 bar g	(5802 psi g)		G
Wetted parts materials			
Seal diaphragm	Process connection		
Stainless steel	Stainless steel		A
Hastelloy	Stainless steel		B
Hastelloy	Hastelloy		C
Version as diaphragm seal ^{2) 3)}			Y
Process connection			
• Connection shank G½A to EN 837-1			0
• Female thread ½-14 NPT			1
• Oval flange made of stainless steel			
- Mounting thread 7/16-20 UNF to EN 61518			2
- Mounting thread M10 to DIN 19213			3
- Mounting thread M12 nach DIN 19213			4
• Male thread M20 x 1,5			5
• Male thread ½-14 NPT			6
Non-wetted parts materials			
• Housing made of die-cast aluminium			0
• Housing stainless steel precision casting			3
Version			
• Standard version			1
• International version, English label inscriptions, documentation in 5 languages on CD			2
Explosion protection			
• Without			A
• With CENELEC, Type of protection:			
- "Intrinsic safety (EEx ia)"			B
- "Explosion-proof (EEx d)" ⁴⁾		F)	D
- "Intrinsic safety and explosion-proof enclosure F (EEx ia + EEx d)" ⁵⁾			P
- "Ex nA/nL (zone 2)"			E
- "Intrinsic safety, explosion-proof enclosure and F) dust explosion protection (EEx ia + EEx d + Zone 1D/2D)" ⁶⁾ (not for DS III FF)			R
• With FM + CSA, Type of protection:			
- "Intrinsic safety and explosion-proof (is + xp)" ⁵⁾		F)	NC
Electrical connection / cable entry			
• Screwed gland M20x1.5			B
• Screwed gland ½-14 NPT			C
• Plug M12 (metal) ⁶⁾			F
Display			
• Without (digital display hidden)			1
• With visible digital indicator			6
• With customer-specific digital indicator (setting as specified, Order code "Y21" or required)			7

- 1) For oxygen application, add Order code E10.
 - 2) When the manufacturer's certificate M (calibration certificate) has to be ordered for transmitters with diaphragm seals, it is recommended only to order this certificate exclusively with the diaphragm seals. The measuring accuracy of the total combination is certified here.
 - 3) When the acceptance test certificate 3.1 for transmitters with direct-connected diaphragm seals is ordered, this certificate must also be ordered with the corresponding seals.
 - 4) Without cable gland, with blanking plug.
 - 5) With enclosed cable gland EEx ia and blanking plug.
 - 6) Cannot be used together with the following types of protection: "Explosion-proof" and "Intrinsic safety and explosion-proof"
- F) Subject to export regulations AL: 9I999, ECCN: N.

Factory-mounting of shut-off valves and valve manifolds see page 2/133.

The device is delivered together with brief instructions (Leporello) and a CD-ROM containing detailed documentation.

SITRANS P measuring instruments for pressure

Transmitters for gage, absolute and differential pressure, flow and level

DS III series
for gage pressure

2

Selection and Ordering data	Order code			
Further designs Add "-Z" to Order No. and specify Order code.		HART	PA	FF
Pressure transmitter with mounting bracket made of:				
• Steel	A01	✓	✓	✓
• Stainless steel	A02	✓	✓	✓
Plug				
• Han 7D (metal, gray)	A30	✓		
• Han 8U (instead of Han 7D)	A31	✓		
Cable sockets for M12 connectors (metal)	A50	✓	✓	✓
Rating plate inscription (instead of German)				
• English	B11	✓	✓	✓
• French	B12	✓	✓	✓
• Spanish	B13	✓	✓	✓
• Italian	B14	✓	✓	✓
English rating plate	B21	✓	✓	✓
Pressure units in inH ₂ O or psi				
Manufacturer's test certificate M (calibration certificate)¹⁾ To DIN 55350, Part 18 and to ISO 8402	C11	✓	✓	✓
Acceptance test certificate²⁾ To EN 10204-3.1	C12	✓	✓	✓
Factory certificate To EN 10204-2.2	C14	✓	✓	✓
"Functional Safety (SIL)" certificate	C20	✓		
"PROFIsafe" certificate and protocol	C21		✓	
Setting of upper limit of output signal to 22.0 mA	D05	✓		
Manufacturer's declaration acc. to NACE	D07	✓	✓	✓
Type of protection IP68 (not together with 7D/ Han 8U plug, cable gland Pg 13.5)	D12	✓	✓	✓
Digital indicator alongside the input keys (only together with the devices 7MF4033-...-0-.A.6 or -.A.7-Z, Y21 or Y22 + Y01)	D27	✓	✓	✓
Supplied with oval flange (1 item), PTFE packing and screws in thread of oval flange	D37 ^{F)}	✓	✓	✓
Use in or on zone 1D/2D (only together with type of protection "Intrinsic safety (EEx ia)")	E01	✓	✓	✓
Use on zone 0 (only together with type of protection "Intrinsic safety (EEx ia)")	E02	✓	✓	✓
Oxygen application (max. 160 bar g (2320 psi g) for oxygen measurement and inert liquid)	E10	✓	✓	✓
Explosion-proof "Intrinsic safety" to INMETRO (Brazil) (only for transmitter 7MF4...-...-.B..)	E25	✓	✓	✓
Explosion-proof "Intrinsic safety" to NEPSI (China) (only for transmitter 7MF4...-...-.B..)	E55	✓	✓	✓
Explosion protection "Explosion-proof" to NEPSI (China) (only for transmitter 7MF4...-...-.D..)	E56	✓	✓	✓
Explosion-proof "Zone 2" to NEPSI (China) (only for transmitter 7MF4...-...-.E..)	E57	✓	✓	✓

¹⁾ When the manufacturer's certificate M (calibration certificate) has to be ordered for transmitters with diaphragm seals, it is recommended only to order this certificate exclusively with the diaphragm seals. The measuring accuracy of the total combination is certified here.

²⁾ When the acceptance test certificate 3.1 for transmitters with direct-connected diaphragm seals is ordered, this certificate must also be ordered with the corresponding seals.

Selection and Ordering data	Order code			
Additional data Add "-Z" to Order No. and specify Order code.		HART	PA	FF
Measuring range to be set Specify in plain text (max. 5 digits): Y01: ... up to ... mbar, bar, kPa, MPa, psi	Y01	✓		
Measuring point number (TAG No.) Max. 16 characters, specify in plain text: Y15:	Y15	✓	✓	✓
Measuring point text Max. 27 characters, specify in plain text: Y16:	Y16	✓	✓	✓
Entry of HART address (TAG) Max. 8 characters, specify in plain text: Y17:	Y17	✓		
Setting of pressure indication in pressure units Specify in plain text (standard setting: mA): Y21: mbar, bar, kPa, MPa, psi, ... Note: The following pressure units can be selected: bar, mbar, mm H ₂ O ¹⁾ , inH ₂ O ¹⁾ , ftH ₂ O ¹⁾ , mmHG, inHG, psi, Pa, kPa, MPa, g/cm ² , kg/cm ² , Torr, ATM oder %) ref. temperature 20 °C	Y21	✓	✓	✓
Setting of pressure indication in non-pressure units Specify in plain text: Y22: up to l/min, m ³ /h, m, USgpm, ... (specification of measuring range in pressure units "Y01" is essential, unit with max. 5 characters)	Y22 + Y01	✓		
Preset bus address Specify in plain text: Y25:	Y25		✓	

Only "Y01", "Y21", "Y22", "Y25" and "D05" can be factory preset

✓ = available

Ordering example

Item line: 7MF4033-1EA00-1AA7-Z
B line: A01 + Y01 + Y21
C line: Y01: 10 ... 20 bar (145 ... 290 psi)
C line: Y21: bar (psi)

F) Subject to export regulations AL: 91999, ECCN: N.

SITRANS P measuring instruments for pressure

Transmitters for gage, absolute and differential pressure, flow and level

DS III series
for gage pressure

Dimensional drawings

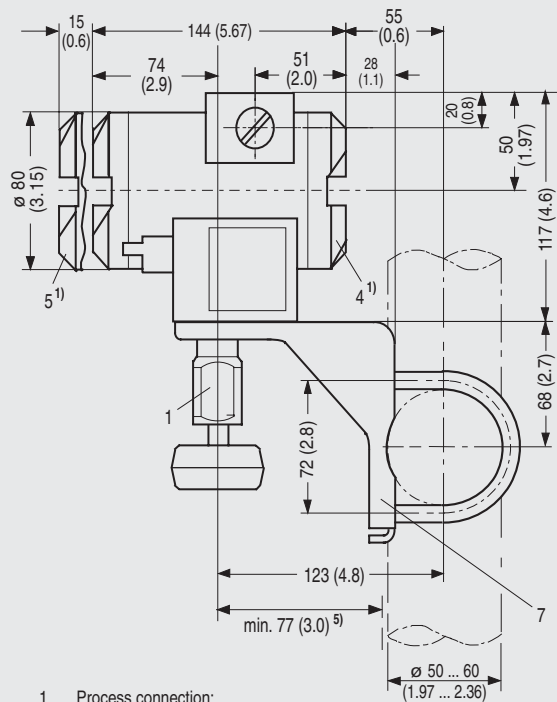

- 1 Process connection:
 - 1/2-14 NPT,
 - connection shank G1/2A or
 - oval flange
- 2 Blanking plug
- 3 Electrical connection:
 - screwed gland Pg 13,5 (adapter)^{2) 3)},
 - screwed gland M20x1,5³⁾,
 - screwed gland 1/2-14 NPT or
 - Han 7D/ Han 8U plug^{2) 3)}
- 4 Terminal side
- 5 Electronics side, digital display (longer overall length for cover with window)
- 6 Protective cover over keys
- 7 Mounting bracket (option)
- 8 Screw cover - safety bracket (only for type of protection "Explosion-proof enclosure", not shown in the drawing)

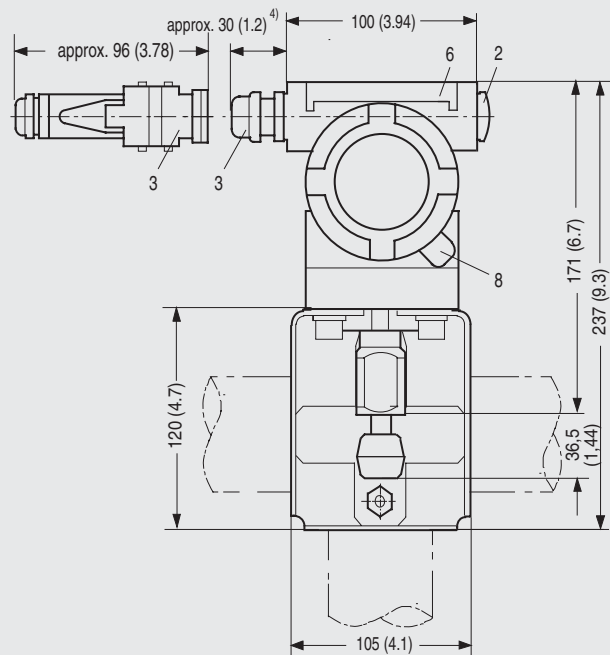

- 1) Allow approx. 20 mm (0.79 inch) thread length to permit unscrewing
- 2) Not with type of protection "explosion-proof enclosure"
- 3) Not with type of protection "FM + CSA [is + xp]"
- 4) 45 mm (1.8 inch) for Pg 13,5 with adapter
- 5) Minimum distance for rotation

SITRANS P pressure transmitters, DS III HART series for gage pressure, dimensions in mm (inch)

SITRANS P measuring instruments for pressure

Transmitters for gage, absolute and differential pressure, flow and level

DS III series
for gage pressure

2

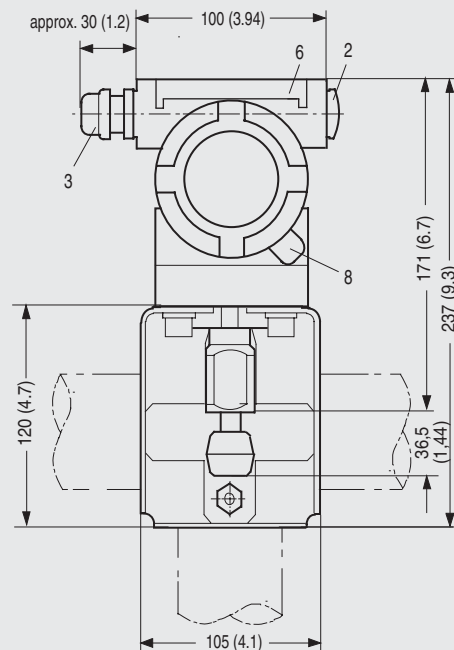
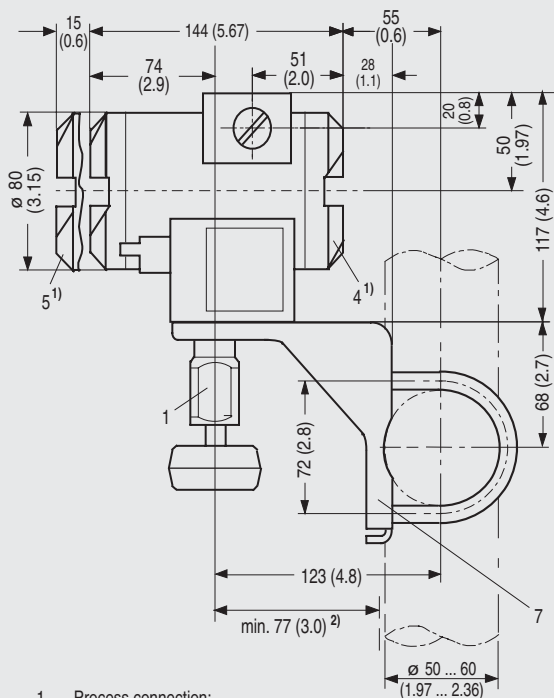

- 1 Process connection:
 - $\frac{1}{2}$ -14 NPT,
 - connection shank G $\frac{1}{2}$ A or
 - oval flange
- 2 Blanking plug
- 3 Electrical connection:
 - screwed gland M20x1,5⁴⁾,
 - screwed gland $\frac{1}{2}$ -14 NPT or
 - PROFIBUS plug M12³⁾⁴⁾
- 4 Terminal side
- 5 Electronics side, digital display (longer overall length for cover with window)
- 6 Protective cover over keys
- 7 Mounting bracket (option)
- 8 Screw cover safety bracket (only for explosion-proof enclosure, not shown in the drawing)

- 1) Allow approx. 20 mm (0.79 inch) thread length in addition
- 2) Minimum distance for rotating
- 3) Not with type of protection "Explosion-proof enclosure".
- 4) Not with type of protection "FM + CSA".

SITRANS P pressure transmitters, DS III PA and FF series for gage pressure, dimensions in mm (inch)

SITRANS P measuring instruments for pressure

Transmitters for gage, absolute and differential pressure, flow and level

DS III series for gage pressure, with front-flush diaphragm

Technical specifications

SITRANS P, DS III series for gage pressure, with front-flush diaphragm

	HART	PROFIBUS PA or FOUNDATION Fieldbus
Input		
Measured variable	Gage pressure	
Spans (infinitely adjustable) or nominal measuring range and max. permissible test pressure	Span	Max. perm. test pressure
	0.01 ... 1 bar g (0.145 ... 14.5 psi g)	6 bar g (87 psi g)
	0.04 ... 4 bar g (0.58 ... 58 psi g)	10 bar g (145 psi g)
	0.16 ... 16 bar g (2.23 ... 232 psi g)	32 bar g (464 psi g)
	0.6 ... 63 bar g (9.14 ... 914 psi g)	100 bar g (1450 psi g)
Lower measuring limit		Nominal measuring range
• Measuring cell with silicone oil filling	100 mbar a (1.45 psi a)	Max. perm. test pressure
Upper measuring limit	100% of max. span	6 bar g (87 psi g)
		10 bar g (145 psi g)
		32 bar g (464 psi g)
		100 bar g (1450 psi g)
Output		
Output signal	4 ... 20 mA	Digital PROFIBUS PA or FOUNDATION Fieldbus signal
• Lower limit (infinitely adjustable)	3.55 mA, factory preset to 3.84 mA	-
• Upper limit (infinitely adjustable)	23 mA, factory preset to 20.5 mA or optionally set to 22.0 mA	-
Load		
• Without HART communication	$R_B \leq (U_H - 10.5 \text{ V})/0.023 \text{ A}$ in Ω , U_H : Power supply in V	-
• With HART communication	$R_B = 230 \dots 500 \Omega$ (SIMATIC PDM) or $R_B = 230 \dots 1100 \Omega$ (HART Communicator)	-
Physical bus	-	IEC 61158-2
With polarity reversal protection	-	Yes
Accuracy	To EN 60770-1	
Reference conditions	Increasing characteristic, start-of-scale value 0 bar, stainless steel seal diaphragm, silicone oil filling, room temperature 25 °C (77 °F) r: Span ratio (r = max. span/set span)	
Error in measurement and fixed-point setting (including hysteresis and repeatability)		
• Linear characteristic		≤ 0,075%
- r ≤ 10	≤ (0.0029 · r + 0.071)%	
- 10 < r ≤ 30	≤ (0.0045 · r + 0.071)%	
- 30 < r ≤ 100	≤ (0.005 · r + 0.05)%	
Long-term drift (temperature change ±30 °C (±54 °F))	≤ (0.25 · r)% every 5 years	≤ 0.25% every 5 years
Influence of ambient temperature		
• at -10 ... +60 °C (14 ... 140 °F)	≤ (0.08 · r + 0.1)%	≤ 0,3%
• at -40 ... -10 °C and +60 ... +85 °C (-40 ... +14 °F and 140 ... 185 °F)	≤ (0.1 · r + 0.15)%/10 K	≤ 0.25%/10 K
Influence of mounting position	0.1 mbar g (0.00145 psi g) per 10° inclination	
Measured Value Resolution	-	3 · 10 ⁻⁵ of nominal measuring range
Influence of the medium temperature (only with front-flush diaphragm)		
• Temperature difference between medium temperature and ambient temperature	3 mbar/10 K (0.04 psi/10 K)	

SITRANS P measuring instruments for pressure

Transmitters for gage, absolute and differential pressure, flow and level

DS III series
for gage pressure, with front-flush diaphragm

2

SITRANS P, DS III series for gage pressure, with front-flush diaphragm

	HART	PROFIBUS PA or FOUNDATION Fieldbus
Rated operating conditions		
Degree of protection (to EN 60529)	IP65	
Process temperature	-20 ... +100 °C (-4 ... +212 °F)	
Ambient conditions		
• Ambient temperature	-20 ... +85 °C (-4 ... +185 °F)	
• Storage temperature	-50 ... +85 °C (-58 ... +185 °F)	
• Climatic class		
- Condensation	Permissible	
• Electromagnetic compatibility		
- Emitted interference and interference immunity	To EN 61326 and NAMUR NE 21	
Design		
Weight (without options)	≈ 1.5 kg (≈ 3.3 lb)	
Housing material	Poor in copper die-cast aluminium, GD-AISI12 or stainless steel precision casting, mat. No. 1.4408	
Wetted parts materials	Stainless steel, mat. No. 1.4404/316L	
Measuring cell filling	Silicone oil or inert filling liquid	
Power supply U_H		
Terminal voltage on transmitter	10.5 ... 45 V DC 10.5 ... 30 V DC in intrinsically-safe mode	Supplied through bus -
Separate 24 V power supply necessary	-	No
Bus voltage		
• Not Ex	-	9 ...32 V
• With intrinsically-safe operation	-	9 ...24 V
Current consumption		
• Basic current (max.)	-	12.5 mA
• Startup current ≤ basic current	-	Yes
• Max. current in event of fault	-	15.5 mA
Fault disconnection electronics (FDE) available	-	Yes
Certificate and approvals		
Classification according to pressure equipment directive (DRGL 97/23/EC)	For gases of fluid group 1 and liquids of fluid group 1; complies with requirements of Article 3, paragraph 3 (sound engineering practice)	

Hygiene version

In the case of SITRANS P DSIII with 7MF413x front-flush diaphragm, selected connections comply with the requirements of EHEDG.

SITRANS P measuring instruments for pressure

Transmitters for gage, absolute and differential pressure, flow and level

DS III series for gage pressure, with front-flush diaphragm

2

HART communication

HART communication	230 ... 1100 Ω
Protocol	HART Version 5.x
Software for computer	SIMATIC PDM

PROFIBUS PA communication

Simultaneous communication with master class 2 (max.)	4
The address can be set using	Configuration tool or local operation (standard setting address 126)
Cyclic data usage	
• Output byte	5 (one measuring value) or 10 (two measuring values)
• Input byte	0, 1, or 2 (register operating mode and reset function for metering)
Internal preprocessing	
Device profile	PROFIBUS PA Profile for Process Control Devices Version 3.0, Class B
Function blocks	2
• Analog input	
- Adaptation to customer-specific process variables	Yes, linearly rising or falling characteristic
- Electrical damping T_{63} , adjustable	0 ... 100 s
- Simulation function	Input /Output
- Failure mode	Can be parameterized (last good value, substitute value, incorrect value)
- Limit monitoring	Yes, one upper and lower warning limit and one alarm limit respectively
• Register (totalizer)	Can be reset, preset, optional direction of counting, simulation function of register output
- Failure mode	Can be parameterized (summation with last good value, continuous summation, summation with incorrect value)
- Limit monitoring	One upper and lower warning limit and one alarm limit respectively
• Physical block	1
Transducer blocks	2
• Pressure transducer block	
- Can be calibrated by applying two pressures	Yes
- Monitoring of sensor limits	Yes
- Specification of a container characteristic with	Max. 30 nodes
- Square-rooted characteristic for flow measurement	Yes
- Gradual volume suppression and implementation point of square-root extraction	Parameterizable
- Simulation function for measured pressure value and sensor temperature	Constant value or over parameterizable ramp function

Communication FOUNDATION Fieldbus

Function blocks	3 function blocks analog input, 1 function block PID
• Analog input	
- Adaptation to customer-specific process variables	Yes, linearly rising or falling characteristic
- Electrical damping T_{63} , adjustable	0 ... 100 s
- Simulation function	Output/input (can be locked within the device with a bridge)
- Failure mode	Can be parameterized (last good value, substitute value, incorrect value)
- Limit monitoring	Yes, one upper and lower warning limit and one alarm limit respectively
- Square-rooted characteristic for flow measurement	Yes
• PID	Standard FF function block
• Physical block	1 Resource block
Transducer blocks	1 transducer block Pressure with calibration, 1 transducer block LCD
• Pressure transducer block	
- Can be calibrated by applying two pressures	Yes
- Monitoring of sensor limits	Yes
- Simulation function: Measured pressure value, sensor temperature and electronics temperature	Constant value or over parameterizable ramp function

SITRANS P measuring instruments for pressure

Transmitters for gage, absolute and differential pressure, flow and level

DS III series
for gage pressure, with front-flush diaphragm

2

Selection and Ordering data		Order No.
SITRANS P pressure transmitters for gage pressure, front-flush membrane, series DS III HART		F) 7MF4133 -
Measuring cell filling	Measuring cell cleaning	
Silicone oil	Standard	1
Inert liquid	Grease-free	3
FDA compliant fill fluid		
• Neobee oil	Standard	4
Span		
0.01 ... 1 bar g ¹⁾	(0.15 ... 14.5 psi g) ¹⁾	B
0.04 ... 4 bar g	(0.58 ... 58 psi g)	C
0.16 ... 16 bar g	(2.32 ... 232 psi g)	D
0.63 ... 63 bar g	(9.14 ... 914 psi g)	E
Wetted parts materials		
Seal diaphragm	Connection shank	
Stainless steel	Stainless steel	A
Process connection		
• Flange version with Order code M.., N.., R.. or Q..		7
Non-wetted parts materials		
• Housing made of die-cast aluminium		0
• Housing stainless steel precision casting		3
Version		
• Standard version		1
• International version, English label inscriptions, documentation in 5 languages on CD		2
Explosion protection		
• Without		A
• With ATEX, Type of protection:		
- "Intrinsic safety (EEx ia)"		B
- "Explosion-proof (EEx d)" ²⁾		D
- "Intrinsic safety, explosion-proof enclosure and dust explosion protection (EEx ia + EEx d + Zone 1D/2D)" ³⁾		R
• With FM + CSA, Type of protection:		
- "Intrinsic safety and explosion-proof (is + xp)" ²⁾ (available soon)		NC
Electrical connection / cable entry		
• Inner thread M20x1.5		B
• Female thread ½-14 NPT		C
• M12 connectors (metal) ⁴⁾		F
Display		
• without (digital indicator hidden, setting: mA)		1
• with visible digital indication, setting: mA		6
• with customer-specific digital indication (setting as specified, Order code "Y21" or "Y22" required)		7

Power supply units see "SITRANS I power supply units and isolation amplifiers".

Included in delivery of the device:

- Brief instructions (Leporello)
- CD-ROM with detailed documentation

1) Only with "Standard" process connection

2) Without cable gland, with blanking plug.

3) With enclosed cable gland EEx ia and blanking plug.

4) Cannot be used together with the following types of protection: "Explosion-proof" and "Intrinsic safety and explosion-proof"

F) Subject to export regulations AL: 91999, ECCN: N.

Selection and Ordering data		Order No.
SITRANS P pressure transmitters for gage pressure, front-flush membrane		
DS III PA series (PROFIBUS PA)		F) 7MF4134 -
DS III FF series (FOUNDATION Fieldbus)		F) 7MF4135 -
Measuring cell filling	Measuring cell cleaning	
Silicone oil	Standard	1
Inert liquid	Grease-free	3
FDA compliant fill fluid		
• Neobee oil	Standard	4
Nominal measuring range		
1 bar g ¹⁾	(14.5 psi g) ¹⁾	B
4 bar g	(58 psi g)	C
16 bar g	(232 psi g)	D
63 bar g	(914 psi g)	E
Wetted parts materials		
Seal diaphragm	Connection shank	
Stainless steel	Stainless steel	A
Process connection		
• Flange version with Order code M.., N.., R.. or Q..		7
Non-wetted parts materials		
• Housing made of die-cast aluminium		0
• Housing stainless steel precision casting		3
Version		
• Standard version		1
• International version, English label inscriptions, documentation in 5 languages on CD		2
Explosion protection		
• Without		A
• With ATEX, Type of protection:		
- "Intrinsic safety (EEx ia)"		B
- "Explosion-proof (EEx d)" ²⁾		D
- "Intrinsic safety, explosion-proof enclosure and dust explosion protection (EEx ia + EEx d + Zone 1D/2D)" ³⁾		R
• With FM + CSA, Type of protection:		
- "Intrinsic safety and explosion-proof (is + xp)" ²⁾ (available soon)		NC
Electrical connection / cable entry		
• Screwed gland M20x1.5		B
• Screwed gland ½-14 NPT		C
• M12 connectors (metal) ⁴⁾		F
Display		
• Without (digital display hidden)		1
• With visible digital display		6
• With customer-specific digital display (setting as specified, Order code "Y21" or required)		7

Included in delivery of the device:

- Brief instructions (Leporello)
- CD-ROM with detailed documentation

1) Only with "Standard" process connection

2) Without cable gland, with blanking plug.

3) With enclosed cable gland EEx ia and blanking plug.

4) Cannot be used together with the following types of protection: "Explosion-proof" and "Intrinsic safety and explosion-proof"

F) Subject to export regulations AL: 91999, ECCN: N.

SITRANS P measuring instruments for pressure

Transmitters for gage, absolute and differential pressure, flow and level

DS III series for gage pressure, with front-flush diaphragm

2

Selection and Ordering data		Order code			Selection and Ordering data		Order code		
<i>Further designs</i>		HART	PA	FF	<i>Further designs</i>		HART	PA	FF
Add "-Z" to Order No. and specify Order code.					Add "-Z" to Order No. and specify Order code.				
Cable sockets for M12 connectors (metal)	A50	✓	✓	✓	Sanitary process connection to DRD • 50 mm, PN 40	M32	✓	✓	✓
Rating plate inscription (instead of German)					Sanitary process connection to NEUMO Bio-Connect screw connection certified to EHEDG				
• English	B11	✓	✓	✓	• DN 50, PN 16	Q05	✓	✓	✓
• French	B12	✓	✓	✓	• DN 65, PN 16	Q06	✓	✓	✓
• Spanish	B13	✓	✓	✓	• DN 80, PN 16	Q07	✓	✓	✓
• Italian	B14	✓	✓	✓	• DN 100, PN 16	Q08	✓	✓	✓
English rating plate	B21	✓	✓	✓	• DN 2", PN 16	Q13	✓	✓	✓
Pressure units in inH ₂ O or psi					• DN 2½", PN 16	Q14	✓	✓	✓
Manufacturer's test certificate M (calibration certificate)	C11	✓	✓	✓	• DN 3", PN 16	Q15	✓	✓	✓
To DIN 55350, Part 18 and to ISO 8402					• DN 4", PN 16	Q16	✓	✓	✓
Acceptance test certificate	C12	✓	✓	✓	Sanitary process connection to NEUMO Bio-Connect flange connection certified to EHEDG				
To EN 10204-3.1					• DN 50, PN 16	Q23	✓	✓	✓
Factory certificate	C14	✓	✓	✓	• DN 65, PN 16	Q24	✓	✓	✓
To EN 10204-2.2					• DN 80, PN 16	Q25	✓	✓	✓
"PROFIsafe" certificate and protocol	C21		✓		• DN 100, PN 16	Q26	✓	✓	✓
Flanges to EN 1092-1					• DN 2", PN 16	Q31	✓	✓	✓
• DN 25, PN 40	M11	✓	✓	✓	• DN 2½", PN 16	Q32	✓	✓	✓
• DN 25, PN 100	M21	✓	✓	✓	• DN 3", PN 16	Q33	✓	✓	✓
• DN 40, PN 40	M13	✓	✓	✓	• DN 4", PN 16	Q34	✓	✓	✓
• DN 40, PN 100	M23	✓	✓	✓	Sanitary process connection to NEUMO Bio-Connect clamp connection certified to EHEDG				
• DN 50, PN 16	M04	✓	✓	✓	• DN 50, PN 16	Q39	✓	✓	✓
• DN 50, PN 40	M14	✓	✓	✓	• DN 65, PN 10	Q40	✓	✓	✓
• DN 80, PN 16	M06	✓	✓	✓	• DN 80, PN 10	Q41	✓	✓	✓
• DN 80, PN 40	M16	✓	✓	✓	• DN 100, PN 10	Q42	✓	✓	✓
Flanges to ASME B16.5					• DN 2½", PN 16	Q48	✓	✓	✓
• Stainless steel flange 1" class 150	M40	✓	✓	✓	• DN 3", PN 10	Q49	✓	✓	✓
• Stainless steel flange 1½" class 150	M41	✓	✓	✓	• DN 4", PN 10	Q50	✓	✓	✓
• Stainless steel flange 2" class 150	M42	✓	✓	✓	Sanitary process connection to NEUMO Connect S flange connection certified to EHEDG				
• Stainless steel flange 2" class 300	M47	✓	✓	✓	• DN 50, PN 16	Q63	✓	✓	✓
• Stainless steel flange 3" class 150	M43	✓	✓	✓	• DN 65, PN 10	Q64	✓	✓	✓
• Stainless steel flange 3" class 300	M48	✓	✓	✓	• DN 80, PN 10	Q65	✓	✓	✓
• Stainless steel flange 4" class 150	M44	✓	✓	✓	• DN 100, PN 10	Q66	✓	✓	✓
• Stainless steel flange 4" class 300	M49	✓	✓	✓	• DN 2", PN 16	Q72	✓	✓	✓
Threaded connection	R04	✓	✓	✓	• DN 2½", PN 10	Q73	✓	✓	✓
G 2", flush-mounted					• DN 3", PN 10	Q74	✓	✓	✓
Tank connection	R10	✓	✓	✓	• DN 4", PN 10	Q75	✓	✓	✓
TG 50/52, PN 40					Sanitary process connection according DIN 11851 (Dairy connection)				
Sanitary process connection according DIN 11851 (Dairy connection)					• DN 50, PN 25	N04	✓	✓	✓
• DN 50, PN 25	N04	✓	✓	✓	• DN 80, PN 25	N06	✓	✓	✓
• DN 80, PN 25	N06	✓	✓	✓	Tri-Clamp connection according DIN 32676/ISO 2852				
Tri-Clamp connection according DIN 32676/ISO 2852					• DN 50/2", PN 16	N14	✓	✓	✓
• DN 50/2", PN 16	N14	✓	✓	✓	• DN 65/3", PN 10	N15	✓	✓	✓
• DN 65/3", PN 10	N15	✓	✓	✓	Varivent connection certified to EHEDG				
Varivent connection certified to EHEDG					• Type N = 68 for Varivent housing DN 40 ... 125 and 1½" ... 6", PN 40	N28	✓	✓	✓
• Type N = 68 for Varivent housing DN 40 ... 125 and 1½" ... 6", PN 40	N28	✓	✓	✓	Temperature decoupler up to 200 °C¹⁾ for version with front-flush diaphragm	P00	✓	✓	✓
Temperature decoupler up to 200 °C¹⁾ for version with front-flush diaphragm	P00	✓	✓	✓	Bio-Control (Neumo) sanitary connection certified to EHEDG				
Bio-Control (Neumo) sanitary connection certified to EHEDG					• DN 50, PN 16	Q53	✓	✓	✓
• DN 50, PN 16	Q53	✓	✓	✓	• DN 65, PN 16	Q54	✓	✓	✓
• DN 65, PN 16	Q54	✓	✓	✓					

¹⁾ The maximum temperatures of the medium depend on the respective cell fillings.

SITRANS P measuring instruments for pressure

Transmitters for gage, absolute and differential pressure, flow and level

DS III series
for gage pressure, with front-flush diaphragm

2

Selection and Ordering data	Order code			
<i>Additional data</i>		HART	PA	FF
Add "-Z" to Order No. and specify Order code.				
Measuring range to be set Specify in plain text (max. 5 digits): Y01: ... up to ... mbar, bar, kPa, MPa, psi	Y01	✓		
Measuring point number (TAG No.) Max. 16 characters, specify in plain text: Y15:	Y15	✓	✓	✓
Measuring point text Max. 27 characters, specify in plain text: Y16:	Y16	✓	✓	✓
Setting of pressure indicator in pressure units Specify in plain text (standard setting: mA): Y21: mbar, bar, kPa, MPa, psi, ... Note: The following pressure units can be selected: bar, mbar, mm H ₂ O [†] , inH ₂ O [†] , ftH ₂ O [†] , mmHG, inHG, psi, Pa, kPa, MPa, g/cm ² , kg/cm ² , Torr, ATM oder % *) ref. temperature 20 °C	Y21	✓	✓	✓

Only "Y01" and "Y21" can be factory preset

✓ = available

Ordering example

Item line: 7MF4133-1DB20-1AB7-Z
B line: A22 + Y01 + Y21
C line: Y01: 1 ... 10 bar (14.5 ... 145 psi)
C line: Y21: bar (psi)

SITRANS P measuring instruments for pressure

Transmitters for gage, absolute and differential pressure, flow and level

DS III series
for gage pressure, with front-flush diaphragm

Dimensional drawings

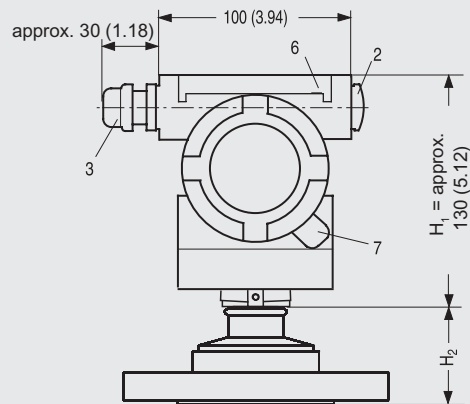
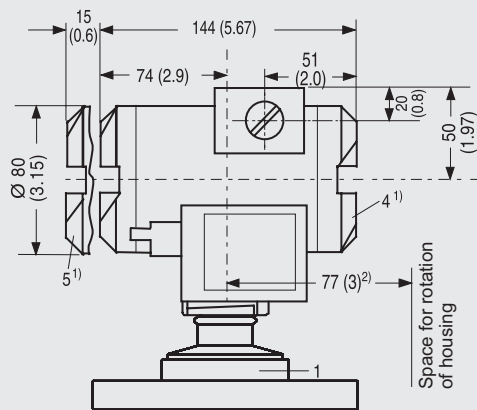

- 1 Process connection: see flange tables
- 2 Blanking plug
- 3 Electrical connection:
- screwed gland M20x1.5
- screwed gland 1/2-14 NPT
- 4 Terminal side
- 5 Electronics side, digital display (longer overall length for cover with window)
- 6 Protective cover over keys
- 7 Screw cover safety bracket (only for explosion-proof enclosure, not shown in the drawing)

- 1) Allow approx. 20 mm (0.79 inch) thread length in addition
- 2) 92 mm (3.6 inch) for minimum distance to permit rotation with indicator

SITRANS P pressure transmitters, DS III series for gage pressure, with front-flush diaphragm, dimensions in mm (inch)

The diagram shows a SITRANS P DS III with an example of a flange. In this drawing the height is subdivided into H_1 and H_2 .

H_1 = Height of the SITRANS DS III up to a defined cross-section

H_2 = Height of the flange up to this defined cross-section

Only the height H_2 is indicated in the dimensions of the flanges.

Flanges to EN and ASME

Flanges to EN

EN 1092-1

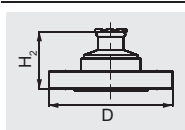

DN	PN	ØD	H_2
25	40	115 mm (4.5")	Approx. 52 mm (2")
25	100	140 mm (5.5")	
40	40	150 mm (5.9")	
40	100	170 mm (6.7")	
50	16	165 mm (6.5")	
50	40	165 mm (6.5")	
80	16	200 mm (7.9")	
80	40	200 mm (7.9")	

Flanges to ASME

ASME B16.5

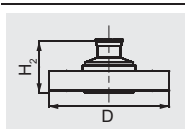

DN	class	ØD	H_2
1"	150	110 mm (4.3")	Approx. 52 mm (2")
1"	300	125 mm (4.9")	
1½"	150	130 mm (5.1")	
1½"	300	155 mm (6.1")	
2"	150	150 mm (5.9")	
2"	300	165 mm (6.5")	
3"	150	190 mm (7.5")	
3"	300	210 mm (8.1")	
4"	150	230 mm (9.1")	
4"	300	255 mm (10.0")	

NuG and pharmaceutical connections

Connections to DIN

DIN 11851 (Dairy connection)

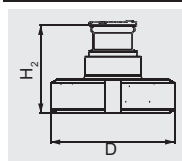

DN	PN	ØD	H_2
50	25	92 mm (3.6")	Approx. 52 mm (2")
80	25	127 mm (5.0")	

Tri-Clamp according DIN 32676

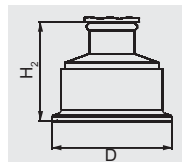

DN	PN	ØD	H_2
50	16	64 mm (2.5")	Approx. 52 mm (2")
65	16	91 mm (3.6")	

Other connections

Varivent connection

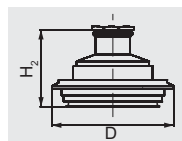

DN	PN	ØD	H_2
40 ... 125	40	84 mm (3.3")	Approx. 52 mm (2")

Bio-Control connection

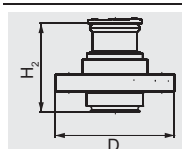

DN	PN	ØD	H_2
50	16	90 mm (3.5")	Approx. 52 mm (2")
65	16	120 mm (4.7")	

SITRANS P measuring instruments for pressure

Transmitters for gage, absolute and differential pressure, flow and level

DS III series
for gage pressure, with front-flush diaphragm

2

Sanitary process connection to DRD

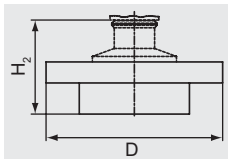

DN	PN	ØD	H ₂
50	40	105 mm (4.1")	Approx. 52 mm (2")

Sanitary process screw connection to NEUMO Bio-Connect

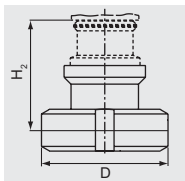

DN	PN	ØD	H ₂
50	16	82 mm (3.2")	Approx. 52 mm (2")
65	16	105 mm (4.1")	
80	16	115 mm (4.5")	
100	16	145 mm (5.7")	
2"	16	82 mm (3.2")	
2½"	16	105 mm (4.1")	
3"	16	105 mm (4.1")	
4"	16	145 mm (5.7")	

Sanitary connection to NEUMO Bio-Connect flange connection

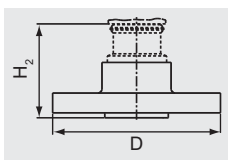

DN	PN	ØD	H ₂
50	16	110 mm (4.3")	Approx. 52 mm (2")
65	16	140 mm (5.5")	
80	16	150 mm (5.9")	
100	16	175 mm (6.9")	
2"	16	100 mm (3.9")	
2½"	16	110 mm (4.3")	
3"	16	140 mm (5.5")	
4"	16	175 mm (6.9")	

Sanitary connection to NEUMO Bio-Connect clamp connection

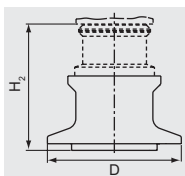

DN	PN	ØD	H ₂
50	16	77,4 mm (3.0")	Approx. 52 mm (2")
65	10	90,9 mm (3.6")	
80	10	106 mm (4.2")	
100	10	119 mm (4.7")	
2"	16	64 mm (2.5")	
2½"	16	77,4 mm (3.0")	
3"	10	90,9 mm (3.6")	
4"	10	119 mm (4.7")	

Sanitary connection to NEUMO Bio-Connect S flange connection

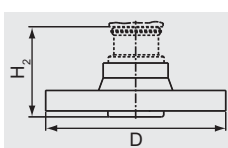

DN	PN	ØD	H ₂
50	16	125 mm (4.9")	Approx. 52 mm (2")
65	10	145 mm (5.7")	
80	10	155 mm (6.1")	
100	10	180 mm (7.1")	
2"	16	125 mm (4.9")	
2½"	10	135 mm (5.3")	
3"	10	145 mm (5.7")	
4"	10	180 mm (7.1")	

Thread connection G2" to DIN 3852

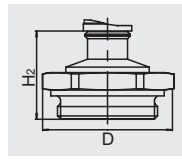

DN	PN	ØD	H ₂
2"	63	78 mm (3.1")	Approx. 52 mm (2")

Tank connection TG52/50

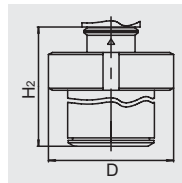

DN	PN	ØD	H ₂
25	40	63 mm (2.5")	Approx. 63 mm (2.5")

SITRANS P measuring instruments for pressure

Transmitters for gage, absolute and differential pressure, flow and level

DS III series for absolute pressure (from gage pressure series)

Technical specifications

SITRANS P, DS III series for absolute pressure (from the gage pressure series)

	HART	PROFIBUS PA or FOUNDATION Fieldbus
Input	Absolute pressure	
Measured variable	Span	
Spans (infinitely adjustable) or nominal measuring range and max. permissible test pressure	Max. perm. test pressure	Nominal measuring range
	Max. perm. test pressure	Max. perm. test pressure
	8.3 ... 250 mbar a (0.12 ... 3.6 psi a)	250 mbar a (3.6 psi a)
	43 ... 1300 mbar a (0.62 ... 18.9 psi a)	1300 mbar a (18.9 psi a)
	160 ... 5000 mbar a (2.32 ... 72.5 psi a)	5 bar a (72.5 psi a)
	1 ... 30 bar a (14.5 ... 435 psi a)	30 bar a (435 psi a)
Lower measuring limit	0 mbar a (0 psi a)	
• Measuring cell with silicone oil filling	100% of max. span	
Upper measuring limit		
Output	4 ... 20 mA	
Output signal	Digital PROFIBUS PA or FOUNDATION Fieldbus signal	
• Lower limit (infinitely adjustable)	3.55 mA, factory preset to 3.84 mA	-
• Upper limit (infinitely adjustable)	23 mA, factory preset to 20.5 mA or optionally set to 22.0 mA	-
Load		
• Without HART communication	$R_B \leq (U_H - 10.5 \text{ V})/0.023 \text{ A}$ in Ω , U_H : Power supply in V	-
• With HART communication	$R_B = 230 \dots 500 \Omega$ (SIMATIC PDM) or $R_B = 230 \dots 1100 \Omega$ (HART Communicator)	-
Physical bus	- IEC 61158-2	
With polarity reversal protection	- Yes	
Accuracy	To EN 60770-1	
Reference conditions	Increasing characteristic, start-of-scale value 0 bar, stainless steel seal diaphragm, silicone oil filling, room temperature 25 °C (77 °F) r: Span ratio (r = max. span / set span)	
Error in measurement and fixed-point setting (including hysteresis and repeatability)		
• Linear characteristic		≤ 0.1%
- r ≤ 10	≤ 0.1%	
- 10 < r ≤ 30	≤ 0.2%	
Long-term drift (temperature change ±30 °C (±54 °F))	≤ (0.1 · r)%/year	≤ 0.1%/year
Influence of ambient temperature		
• at -10 ... +60 °C (14 ... 140 °F)	≤ (0.1 · r + 0.2)%	≤ 0.3%
• at -40 ... -10 °C and +60 ... +85 °C (-40 ... +14 °F and 140 ... 185 °F)	≤ (0.1 · r + 0.15)%/10 K	≤ 0.25%/10 K
Measured Value Resolution	3 · 10 ⁻⁵ of nominal measuring range	

SITRANS P measuring instruments for pressure

Transmitters for gage, absolute and differential pressure, flow and level

DS III series for absolute pressure
(from gage pressure series)

2

SITRANS P, DS III series for absolute pressure (from the gage pressure series)

	HART	PROFIBUS PA or FOUNDATION Fieldbus
Rated operating conditions		
Degree of protection (to EN 60529)	IP65	
Process temperature		
• Measuring cell with silicone oil filling	-40 ... +100 °C (-40 ... +212 °F)	
• Measuring cell with inert filling liquid	-20 ... +100 °C (-4 ... +212 °F)	
• In conjunction with dust explosion protection	-20 ... +60 °C (-4 ... +140 °F)	
Ambient conditions		
• Ambient temperature		
- Digital indicators	-30 ... +85 °C (-22 ... +185 °F)	
• Storage temperature	-50 ... +85 °C (-58 ... +185 °F)	
• Climatic class		
- Condensation	Permissible	
• Electromagnetic compatibility		
- Emitted interference and interference immunity	To EN 61326 and NAMUR NE 21	
Design		
Weight (without options)	≈ 1.5 kg (≈ 3.3 lb)	
Housing material	Poor in copper die-cast aluminium, GD-AISI12 or stainless steel precision casting, mat. No. 1.4408	
Wetted parts materials		
• Connection shank	Stainless steel, mat. No. 1.4404/316L or Hastelloy C4, mat. No. 2.4610	
• Oval flange	Stainless steel, mat. No. 1.4404/316L	
• Seal diaphragm	Stainless steel, mat. No. 1.4404/316L or Hastelloy C276, mat. No. 2.4819	
Measuring cell filling	Silicone oil or inert filling liquid (max. 160 bar a (2320 psi a) with oxygen measurement)	
Process connection	Connection shank G½A to DIN EN 837-1, female thread ½ -14 NPT or oval flange (PN 160 (MWP 2320 psi a)) to DIN 19213 with mounting thread M10 or 7/16-20 UNF to EN 61518	
Power supply U_H		
Terminal voltage on transmitter	10.5 ... 45 V DC 10.5 ... 30 V DC in intrinsically-safe mode	Supplied through bus -
Separate 24 V power supply necessary	-	No
Bus voltage		
• Not Ex	-	9 ... 32 V
• With intrinsically-safe operation	-	9 ... 24 V
Current consumption		
• Basic current (max.)	-	12.5 mA
• Startup current ≤ basic current	-	Yes
• Max. current in event of fault	-	15.5 mA
Fault disconnection electronics (FDE) available	-	Yes

SITRANS P measuring instruments for pressure

Transmitters for gage, absolute and differential pressure, flow and level

DS III series for absolute pressure (from gage pressure series)

2

SITRANS P, DS III series for absolute pressure (from the gage pressure series)

	HART	PROFIBUS PA or FOUNDATION Fieldbus
Certificate and approvals		
Classification according to pressure equipment directive (DRGL 97/23/EC)	For gases of fluid group 1 and liquids of fluid group 1; complies with requirements of Article 3, paragraph 3 (sound engineering practice)	
Explosion protection		
• Intrinsic safety "i"	PTB 99 ATEX 2122	
- Identification	Ex II 1/2 G EEx ia/ib IIB/IIC T6	
- Permissible ambient temperature	-40 ... +85 °C (-40 ... +185 °F) temperature class T4; -40 ... +70 °C (-40 ... +158 °F) temperature class T5; -40 ... +60 °C (-40 ... +140 °F) temperature class T6	
- Connection	To certified intrinsically-safe circuits with maximum values: $U_i = 30 \text{ V}$, $I_i = 100 \text{ mA}$, $P_i = 750 \text{ mW}$; $R_i = 300 \Omega$	FISCO supply unit: $U_o = 17.5 \text{ V}$, $I_o = 380 \text{ mA}$, $P_o = 5.32 \text{ W}$ Linear barrier: $U_o = 24 \text{ V}$, $I_o = 250 \text{ mA}$, $P_o = 1.2 \text{ W}$
- Effective internal inductance/capacitance	$L_i = 0.4 \text{ mH}$, $C_i = 6 \text{ nF}$	$L_i = 7 \mu\text{H}$, $C_i = 1.1 \text{ nF}$
• Explosion-proof "d"	PTB 99 ATEX 1160	
- Identification	Ex II 1/2 G EEx d IIC T4/T6	
- Permissible ambient temperature	-40 ... +85 °C (-40 ... +185 °F) temperature class T4; -40 ... +60 °C (-40 ... +140 °F) temperature class T6	
- Connection	To circuits with values: $U_H = 10.5 \dots 45 \text{ V DC}$	To circuits with values: $U_H = 9 \dots 32 \text{ V DC}$
• Dust explosion protection for zone 20	PTB 01 ATEX 2055	
- Identification	Ex II 1 D IP65 T 120 °C Ex II 1/2 D IP65 T 120 °C	
- Permissible ambient temperature	-40 ... +85 °C (-40 ... +185 °F)	
- Max. surface temperature	120 °C (248 °F)	
- Connection	To certified intrinsically-safe circuits with maximum values: $U_i = 30 \text{ V}$, $I_i = 100 \text{ mA}$, $P_i = 750 \text{ mW}$, $R_i = 300 \Omega$	FISCO supply unit: $U_o = 17.5 \text{ V}$, $I_o = 380 \text{ mA}$, $P_o = 5.32 \text{ W}$ Linear barrier: $U_o = 24 \text{ V}$, $I_o = 250 \text{ mA}$, $P_o = 1.2 \text{ W}$
- Effective internal inductance/capacitance	$L_i = 0.4 \text{ mH}$, $C_i = 6 \text{ nF}$	$L_i = 7 \mu\text{H}$, $C_i = 1.1 \text{ nF}$
• Dust explosion protection for zone 21/22	PTB 01 ATEX 2055	
- Identification	Ex II 2 D IP65 T 120 °C	
- Connection	To circuits with values: $U_H = 10.5 \dots 45 \text{ V DC}$; $P_{\text{max}} = 1.2 \text{ W}$	To circuits with values: $U_H = 9 \dots 32 \text{ V DC}$; $P_{\text{max}} = 1.2 \text{ W}$
• Type of protection "n" (zone 2)	TÜV 01 ATEX 1696 X	Planned
- Identification	Ex II 3 G EEx nA L IIC T4/T5/T6	-
• Explosion protection to FM	Certificate of Compliance 3008490	
- Identification (XP/DIP) or (IS); (NI)	CL I, DIV 1, GP ABCD T4...T6; CL II, DIV 1, GP EFG; CL III; CL I, ZN 0/1 AEx ia IIC T4...T6; CL I, DIV 2, GP ABCD T4...T6; CL II, DIV 2, GP FG; CL III	
• Explosion protection to CSA	Certificate of Compliance 1153651	
- Identification (XP/DIP) or (IS)	CL I, DIV 1, GP ABCD T4...T6; CL II, DIV 1, GP EFG; CL III; Ex ia IIC T4...T6; CL I, DIV 2, GP ABCD T4...T6; CL II, DIV 2, GP FG; CL III	

SITRANS P measuring instruments for pressure

Transmitters for gage, absolute and differential pressure, flow and level

DS III series for absolute pressure (from gage pressure series)

2

HART communication

HART communication	230 ... 1100 Ω
Protocol	HART Version 5.x
Software for computer	SIMATIC PDM

PROFIBUS PA communication

Simultaneous communication with master class 2 (max.)	4
The address can be set using	Configuration tool or local operation (standard setting address 126)
Cyclic data usage	
• Output byte	5 (one measuring value) or 10 (two measuring values)
• Input byte	0, 1, or 2 (register operating mode and reset function for metering)
Internal preprocessing	
Device profile	PROFIBUS PA Profile for Process Control Devices Version 3.0, Class B
Function blocks	2
• Analog input	
- Adaptation to customer-specific process variables	Yes, linearly rising or falling characteristic
- Electrical damping T_{63} , adjustable	0 ... 100 s
- Simulation function	Input /Output
- Failure mode	Can be parameterized (last good value, substitute value, incorrect value)
- Limit monitoring	Yes, one upper and lower warning limit and one alarm limit respectively
• Register (totalizer)	Can be reset, preset, optional direction of counting, simulation function of register output
- Failure mode	Can be parameterized (summation with last good value, continuous summation, summation with incorrect value)
- Limit monitoring	One upper and lower warning limit and one alarm limit respectively
• Physical block	1
Transducer blocks	2
• Pressure transducer block	
- Can be calibrated by applying two pressures	Yes
- Monitoring of sensor limits	Yes
- Specification of a container characteristic with	Max. 30 nodes
- Square-rooted characteristic for flow measurement	Yes
- Gradual volume suppression and implementation point of square-root extraction	Parameterizable
- Simulation function for measured pressure value and sensor temperature	Constant value or over parameterizable ramp function

Communication FOUNDATION Fieldbus

Function blocks	3 function blocks analog input, 1 function block PID
• Analog input	
- Adaptation to customer-specific process variables	Yes, linearly rising or falling characteristic
- Electrical damping T_{63} , adjustable	0 ... 100 s
- Simulation function	Output/input (can be locked within the device with a bridge)
- Failure mode	Can be parameterized (last good value, substitute value, incorrect value)
- Limit monitoring	Yes, one upper and lower warning limit and one alarm limit respectively
- Square-rooted characteristic for flow measurement	Yes
• PID	Standard FF function block
• Physical block	1 Resource block
Transducer blocks	1 transducer block Pressure with calibration, 1 transducer block LCD
• Pressure transducer block	
- Can be calibrated by applying two pressures	Yes
- Monitoring of sensor limits	Yes
- Simulation function: Measured pressure value, sensor temperature and electronics temperature	Constant value or over parameterizable ramp function

SITRANS P measuring instruments for pressure

Transmitters for gage, absolute and differential pressure, flow and level

DS III series for absolute pressure (from gage pressure series)

2

Selection and Ordering data		Order No.
SITRANS P pressure transmitters for absolute pressure, from the pressure series DS III HART		7MF4233-
Measuring cell filling	Measuring cell cleaning	
Silicone oil	Standard	1
Inert liquid ¹⁾	Grease-free	3
Span		
8.3 ... 250 mbar a (0.12 ... 3.63 psi a)		D
43 ... 1300 mbar a (0.62 ... 18.9 psi a)		F
0.16 ... 5 bar a (2.32 ... 72.5 psi a)		G
1 ... 30 bar a (14.5 ... 435 psi a)		H
Wetted parts materials		
Seal diaphragm	Process connection	
Stainless steel	Stainless steel	A
Hastelloy	Stainless steel	B
Hastelloy	Hastelloy	C
Version for diaphragm seal ²⁾³⁾⁴⁾		Y
Process connection		
• Connection shank G $\frac{1}{2}$ A to EN 837-1		0
• Female thread $\frac{1}{2}$ -14 NPT		1
• Oval flange made of stainless steel		
- Mounting thread $\frac{7}{16}$ -20 UNF to EN 61518		2
- Mounting thread M10 to DIN 19213		3
• Male thread M20 x 1,5		5
• Male thread $\frac{1}{2}$ -14 NPT		6
Non-wetted parts materials		
• Housing made of die-cast aluminium		0
• Housing stainless steel precision casting ⁵⁾		3
Version		
• Standard version		1
• International version, English label inscriptions, documentation in 5 languages on CD		2
Explosion protection		
• Without		A
• With ATEX, Type of protection:		
- "Intrinsic safety (EEx ia)"		B
- "Explosion-proof (EEx d)" ⁶⁾		D
- "Intrinsic safety and explosion-proof enclosure (EEx ia + EEx d)" ⁷⁾		P
- "Ex nA/nL (zone 2)"		E
- "Intrinsic safety, explosion-proof enclosure and dust explosion protection (EEx ia + EEx d + Zone 1D/2D)" ⁷⁾		R
• With FM + CSA, Type of protection:		
- "Intrinsic safety and explosion-proof (is + xp)" ⁶⁾		NC
Electrical connection / cable entry		
• Screwed gland Pg 13.5 ⁸⁾		A
• Screwed gland M20x1.5		B
• Screwed gland $\frac{1}{2}$ -14 NPT		C
• Han 7D plug (plastic housing) incl. mating connector ⁸⁾		D
• Plug M12 (metal) ⁹⁾		F
Display		
• Without (digital indicator hidden, setting: mA)		1
• With visible digital indicator		6
• With customer-specific digital indicator (setting as specified, Order code "Y21" or required)		7

- 1) For oxygen application, add Order code E10.
- 2) Version 7MF4233-1DY... only up to max. span 200 mbar a (2.9 psi a)
- 3) When the manufacturer's certificate M (calibration certificate) has to be ordered for transmitters with diaphragm seals, it is recommended only to order this certificate exclusively with the diaphragm seals. The measuring accuracy of the total combination is certified here.
- 4) When the acceptance test certificate 3.1 for transmitters with direct-connected diaphragm seals is ordered, this certificate must also be ordered with the corresponding seals.
- 5) Not together with Electrical connection „Screwed gland Pg 13.5“ and „Han7D plug“.
- 6) Without cable gland, with blanking plug.
- 7) With enclosed cable gland EEx ia and blanking plug.
- 8) Not together with type of protection "Explosion-proof" and type of protection "Ex nA".
- 9) Not together with types of protection "Explosion-proof" or "Intrinsic safety and explosion-proof"

F) Subject to export regulations AL: 9I999, ECCN: N.

Power supply units see "SITRANS I power supply units and isolation amplifiers".

Factory-mounting of shut-off valves and valve manifolds see page 2/133.

Included in delivery of the device:

- Brief instructions (Leporello)
- CD-ROM with detailed documentation

SITRANS P measuring instruments for pressure

Transmitters for gage, absolute and differential pressure, flow and level

**DS III series for absolute pressure
(from gage pressure series)**

2

Selection and Ordering data		Order No.
SITRANS P pressure transmitters for absolute pressure (from the gage pressure series)		
DS III PA series (PROFIBUS PA)	F)	7 MF 4 2 3 4 -
DS III FF series (FOUNDATION Fieldbus)	F)	7 MF 4 2 3 5 -
Measuring cell filling		
Silicone oil	Standard	1
Inert liquid ¹⁾	Grease-free	3
Nominal measuring range		
250 mbar a	(3.63 psi a)	D
1300 mbar a	(18.9 psi a)	F
5 bar a	(72.5 psi a)	G
30 bar a	(435 psi a)	H
Wetted parts materials		
Seal diaphragm	Process connection	
Stainless steel	Stainless steel	A
Hastelloy	Stainless steel	B
Hastelloy	Hastelloy	C
Version as diaphragm seal ²⁾³⁾⁴⁾		Y
Process connection		
• Connection shank G $\frac{1}{2}$ A to EN 837-1		0
• Female thread $\frac{1}{2}$ -14 NPT		1
• Oval flange made of stainless steel		
- Mounting thread $\frac{7}{16}$ -20 UNF to EN 61518		2
- Mounting thread M10 to DIN 19213		3
• Male thread M20 x 1,5		5
• Male thread $\frac{1}{2}$ -14 NPT		6
Non-wetted parts materials		
• Housing made of die-cast aluminium		0
• Housing stainless steel precision casting		3
Version		
• Standard version		1
• International version, English label inscriptions, documentation in 5 languages on CD		2
Explosion protection		
• Without		A
• With CENELEC, Type of protection:		
- "Intrinsic safety (EEx ia)"		B
- "Explosion-proof (EEx d)" ⁵⁾		D
- "Intrinsic safety and explosion-proof enclosure (EEx ia + EEx d)" ⁶⁾		P
- "Ex nA/nL (zone 2)"		E
- "Intrinsic safety, explosion-proof enclosure and dust explosion protection (EEx ia + EEx d + Zone 1D/2D)" ⁶⁾ (not for DS III FF)		R
• With FM + CSA, Type of protection:		
- "Intrinsic safety and explosion-proof (is + xp)" ⁵⁾		NC
Electrical connection / cable entry		
• Screwed gland M20x1.5		B
• Screwed gland $\frac{1}{2}$ -14 NPT		C
• Plug M12 incl. mating connector ⁷⁾		F
Display		
• Without (digital display hidden)		1
• With visible digital indicator		6
• With customer-specific digital indicator (setting as specified, Order code "Y21" or required)		7

- 1) For oxygen application, add Order code E10.
- 2) Version 7MF4233-1DY... only up to max. span 200 mbar a (2.9 psi a).
- 3) When the manufacturer's certificate M (calibration certificate) has to be ordered for transmitters with diaphragm seals, it is recommended only to order this certificate exclusively with the diaphragm seals. The measuring accuracy of the total combination is certified here.
- 4) When the acceptance test certificate 3.1 for transmitters with direct-connected diaphragm seals is ordered, this certificate must also be ordered with the corresponding seals.
- 5) Without cable gland, with blanking plug.
- 6) With enclosed cable gland EEx ia and blanking plug.
- 7) Not together with types of protection "Explosion-proof" or "Intrinsic safety and explosion-proof"

F) Subject to export regulations AL: 9I999, ECCN: N.

Factory-mounting of shut-off valves and valve manifolds see page 2/133.

Included in delivery of the device:

- Brief instructions (Leporello)
- CD-ROM with detailed documentation

SITRANS P measuring instruments for pressure

Transmitters for gage, absolute and differential pressure, flow and level

DS III series for absolute pressure (from gage pressure series)

2

Selection and Ordering data		Order code			Selection and Ordering data		Order code				
Further designs			HART	PA	FF	Additional data			HART	PA	FF
Add "-Z" to Order No. and specify Order code.						Add "-Z" to Order No. and specify Order code.					
Pressure transmitter with mounting bracket made of:						Measuring range to be set		Y01	✓		
• Steel		A01	✓	✓	✓	Specify in plain text (max. 5 digits): Y01: ... up to ... mbar, bar, kPa, MPa, psi					
• Stainless steel		A02	✓	✓	✓	Measuring point number (TAG No.)		Y15	✓	✓	✓
Plug						Max. 16 characters, specify in plain text: Y15:					
• Han 7D (metal, gray)		A30	✓			Measuring point text		Y16	✓	✓	✓
• Han 8U (instead of Han 7D)		A31	✓			Max. 27 characters, specify in plain text: Y16:					
Cable sockets for M12 connectors (metal)		A50	✓	✓	✓	Entry of HART address (TAG)		Y17	✓		
Rating plate inscription (instead of German)						Max. 8 characters, specify in plain text: Y17:					
• English		B11	✓	✓	✓	Setting of pressure indication in pressure units		Y21	✓	✓	✓
• French		B12	✓	✓	✓	Specify in plain text (standard setting: mA): Y21: mbar, bar, kPa, MPa, psi, ...					
• Spanish		B13	✓	✓	✓	Note:					
• Italian		B14	✓	✓	✓	The following pressure units can be selected:					
English rating plate		B21	✓	✓	✓	bar, mbar, mm H ₂ O ¹ , inH ₂ O ¹ , ftH ₂ O ¹ , mmHG, inHG, psi, Pa, kPa, MPa, g/cm ² , kg/cm ² , Torr, ATM oder %					
Pressure units in inH ₂ O or psi						*) ref. temperature 20 °C					
Manufacturer's test certificate M (calibration certificate)¹⁾		C11	✓	✓	✓	Setting of pressure indication in non-pressure units		Y22 + Y01	✓	✓	✓
To DIN 55350, Part 18 and to ISO 8402						Specify in plain text: Y22: up to l/min, m ³ /h, m, USgpm, ... (specification of measuring range in pressure units "Y01" is essential, unit with max. 5 characters)					
Acceptance test certificate²⁾		C12	✓	✓	✓	Preset bus address		Y25		✓	
To EN 10204-3.1						Specify in plain text: Y25:					
Factory certificate		C14	✓	✓	✓	Only "Y01", "Y21", "Y22", "Y25" and "D05" can be factory preset					
To EN 10204-2.2						✓ = available					
"Functional Safety (SIL)" certificate		C20	✓			¹⁾ When the manufacture's certificate M (calibration certificate) has to be ordered for transmitters with diaphragm seals, it is recommended only to order this certificate exclusively with the diaphragm seals. The measuring accuracy of the <u>total</u> combination is certified here.					
"PROFIsafe" certificate and protocol		C21		✓		²⁾ Whe the acceptance test certificate 3.1 for transmitters with direct-connected diaphragm seals is ordered, this certificate must also be ordered with the corresponding seals.					
Setting of upper limit of output signal to 22.0 mA		D05	✓								
Manufacturer's declaration acc. to NACE		D07	✓	✓	✓						
Type of protection IP68 (not together with Han 7D / Han 8U plug, Pg 13.5 screwed gland)		D12	✓	✓	✓						
Digital indicator alongside the input keys (only together with the devices 7MF4233-...-0-.A.6 or -.A.7-Z, Y21 or Y22 + Y01).		D27	✓	✓	✓						
Supplied with oval flange (1 item), PTFE packing and screws in thread of oval flange		D37	✓	✓	✓						
Use in or on zone 1D/2D (only together with type of protection "Intrinsic safety (EEx ia)")		E01	✓	✓	✓						
Use on zone 0 (only together with type of protection "Intrinsic safety (EEx ia)")		E02	✓	✓	✓						
Oxygen application (max. 160 bar a (2320 psi a) with oxygen measurement and inert liquid)		E10	✓	✓	✓						
Explosion-proof "Intrinsic safety" to INMETRO (Brazil) (only for transmitter 7MF4...-.....-B..)		E25	✓	✓	✓						
Explosion-proof "Intrinsic safety" to NEPSI (China) (only for transmitter 7MF4...-.....-B..)		E55	✓	✓	✓						
Explosion protection "Explosion-proof" to NEPSI (China) (only for transmitter 7MF4...-.....-D..)		E56	✓	✓	✓						
Explosion-proof "Zone 2" to NEPSI (China) (only for transmitter 7MF4...-.....-E..)		E57	✓	✓	✓						

SITRANS P measuring instruments for pressure

Transmitters for gage, absolute and differential pressure, flow and level

DS III series for absolute pressure
(from gage pressure series)

2

Dimensional drawings

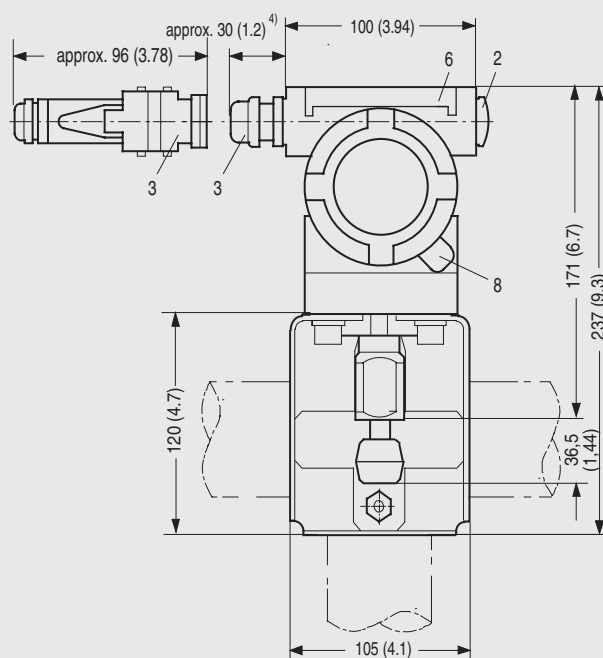
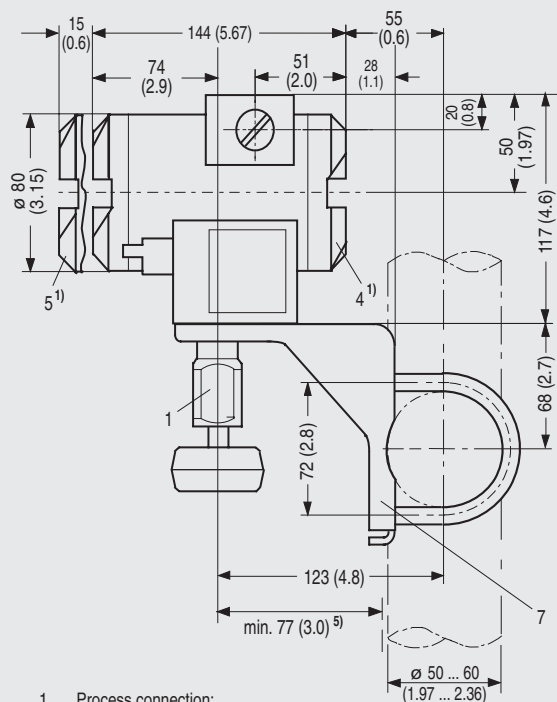

- 1 Process connection:
 - 1/2-14 NPT,
 - connection shank G1/2A or
 - oval flange
- 2 Blanking plug
- 3 Electrical connection:
 - screwed gland Pg 13,5 (adapter)^{2) 3)},
 - screwed gland M20x1,5³⁾,
 - screwed gland 1/2-14 NPT or
 - Han 7D/ Han 8U plug^{2) 3)}
- 4 Terminal side
- 5 Electronics side, digital display (longer overall length for cover with window)
- 6 Protective cover over keys
- 7 Mounting bracket (option)
- 8 Screw cover - safety bracket (only for type of protection "Explosion-proof enclosure", not shown in the drawing)

- 1) Allow approx. 20 mm (0.79 inch) thread length to permit unscrewing
- 2) Not with type of protection "explosion-proof enclosure"
- 3) Not with type of protection "FM + CSA [is + xp]"
- 4) 45 mm (1.8 inch) for Pg 13,5 with adapter
- 5) Minimum distance for rotation

SITRANS P pressure transmitters, DS III HART series for absolute pressure, from the pressure series, dimensions in mm (inch)

SITRANS P measuring instruments for pressure

Transmitters for gage, absolute and differential pressure, flow and level

DS III series for absolute pressure
(from gage pressure series)

2

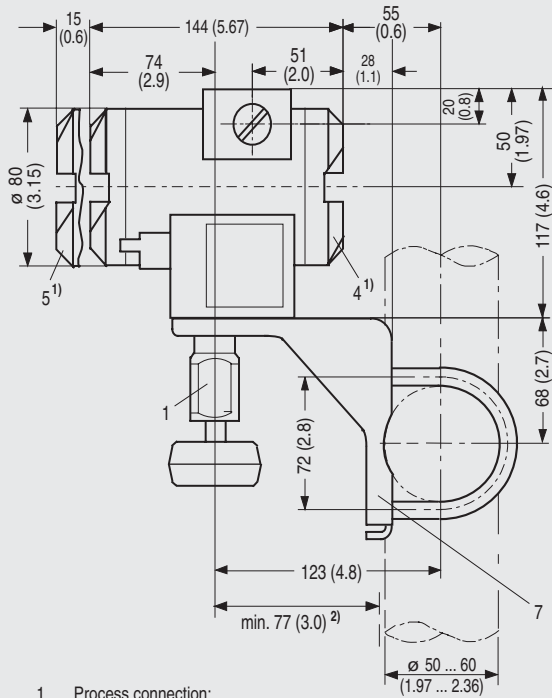

- 1 Process connection:
 - $\frac{1}{2}$ -14 NPT,
 - connection shank G $\frac{3}{4}$ A or
 - oval flange
- 2 Blanking plug
- 3 Electrical connection:
 - screwed gland M20x1,5⁴⁾,
 - screwed gland $\frac{1}{2}$ -14 NPT or
 - PROFIBUS plug M12³⁾⁴⁾
- 4 Terminal side
- 5 Electronics side, digital display (longer overall length for cover with window)
- 6 Protective cover over keys
- 7 Mounting bracket (option)
- 8 Screw cover safety bracket (only for explosion-proof enclosure, not shown in the drawing)

- 1) Allow approx. 20 mm (0.79 inch) thread length in addition
- 2) Minimum distance for rotating
- 3) Not with type of protection "Explosion-proof enclosure".
- 4) Not with type of protection "FM + CSA".

SITRANS P pressure transmitters, DS III PA and FF series for absolute pressure, from the pressure series, dimensions in mm (inch)

SITRANS P measuring instruments for pressure

Transmitters for gage, absolute and differential pressure, flow and level

DS III series for absolute pressure
(from differential pressure series)

2

Technical specifications

SITRANS P, DS III series for absolute pressure (from differential pressure series)

	HART	PROFIBUS PA or FOUNDATION Fieldbus	
Input	Absolute pressure pressure		
Measured variable	Span		
Spans (infinitely adjustable) or nominal measuring range and max. permissible working pressure	Maximum working pressure	Nominal measuring range	Maximum working pressure
	8.3 ... 250 mbar a (0.12 ... 3.6 psi a)	32 bar a (464 psi a)	250 mbar a (3.6 psi a)
	43 ... 1300 mbar a (0.62 ... 18.9 psi a)	32 bar a (464 psi a)	1300 bar a (18.9 psi a)
	160 ... 5000 mbar a (2.32 ... 72.5 psi a)	32 bar a (464 psi a)	5 bar a (72.5 psi a)
	1 ... 30 bar a (14.5 ... 435 psi a)	160 bar a (2320 psi a)	30 bar a (435 psi a)
	5.3 ... 100 bar a (77 ... 1450 psi a)	160 bar a (2320 psi a) (for connection thread M10 and $\frac{7}{16}$ -20 UNF in the process flanges)	100 bar a (1450 psi a)
Lower measuring limit	0 mbar a (0 psi a)		
• Measuring cell with silicone oil filling	100% of max. span		
Upper measuring limit			
Output	4 ... 20 mA		
Output signal	Digital PROFIBUS PA or FOUNDATION Fieldbus signal		
• Lower limit (infinitely adjustable)	3.55 mA, factory preset to 3.84 mA		-
• Upper limit (infinitely adjustable)	23 mA, factory preset to 20.5 mA or optionally set to 22.0 mA		-
Load			
• Without HART communication	$R_B \leq (U_H - 10.5 \text{ V})/0.023 \text{ A}$ in Ω , U_H : Power supply in V		-
• With HART communication	$R_B = 230 \dots 500 \Omega$ (SIMATIC PDM) or $R_B = 230 \dots 1100 \Omega$ (HART Communicator)		-
Physical bus	-		IEC 61158-2
With polarity reversal protection	-		Yes
Accuracy	To EN 60770-1		
Reference conditions	Increasing characteristic, start-of-scale value 0 bar, stainless steel seal diaphragm, silicone oil filling, room temperature 25 °C (77 °F) r: Span ratio (r = max. span / set span)		
Error in measurement and fixed-point setting (including hysteresis and repeatability)			
• Linear characteristic			$\leq 0.1\%$
- r ≤ 10	$\leq 0.1\%$		
- 10 < r ≤ 30	$\leq 0.2\%$		
Long-term drift (temperature change ± 30 °C (± 54 °F))	$\leq (0.1 \cdot r)\%/year$		$\leq 0.1\%/year$
Influence of ambient temperature			
• at -10 ... +60 °C (14 ... 140 °F)	$\leq (0.1 \cdot r + 0.2)\%$		$\leq 0.3\%$
• at -40 ... -10 °C and +60 ... +85 °C (-40 ... +14 °F and 140 ... 185 °F)	$\leq (0.1 \cdot r + 0.15)\%/10 \text{ K}$		$\leq 0.25\%/10 \text{ K}$
Measured Value Resolution	-		$3 \cdot 10^{-5}$ of nominal measuring range

SITRANS P measuring instruments for pressure

Transmitters for gage, absolute and differential pressure, flow and level

DS III series for absolute pressure (from differential pressure series)

2

SITRANS P, DS III series for absolute pressure (from differential pressure series)

	HART	PROFIBUS PA or FOUNDATION Fieldbus
Rated operating conditions		
Degree of protection (to EN 60529)	IP65	
Process temperature		
• Measuring cell with silicone oil filling	-40 ... +100 °C (-40 ... +212 °F)	
• Measuring cell with inert filling liquid	-20 ... +100 °C (-4 ... +212 °F)	
• In conjunction with dust explosion protection	-20 ... +60 °C (-4 ... +140 °F)	
Ambient conditions		
• Ambient temperature		
- Digital indicators	-30 ... +85 °C (-22 ... +185 °F)	
• Storage temperature	-50 ... +85 °C (-58 ... +185 °F)	
• Climatic class		
- Condensation	Permissible	
• Electromagnetic compatibility		
- Emitted interference and interference immunity	To EN 61326 and NAMUR NE 21	
Design		
Weight (without options)	≈ 4.5 kg (≈ 9.9 lb)	
Housing material	Poor in copper die-cast aluminium, GD-AISI12 or stainless steel precision casting, mat. No. 1.4408	
Wetted parts materials		
• Seal diaphragm	Stainless steel, mat. No. 1.4404/316L or Hastelloy C276, mat. No. 2.4819, Monel, mat. No. 2.4360, tantalum or gold	
• Process flanges and sealing screw	Stainless steel, mat. No. 1.4408, Hastelloy C4, mat. No. 2.4610 or Monel, mat. No. 2.4360	
• O-Ring	FPM (Viton) or optionally: PTFE, FEP, FEPM and NBR	
Measuring cell filling	Silicone oil or inert filling liquid (max. 160 bar (2320 psi a) with oxygen measurement)	
Process connection	1/4"-18 NPT and flange connection to DIN 19213 with mounting thread M10 to DIN 19213 or 7/16"-20 UNF to EN 61518	
Power supply U_H		
Terminal voltage on transmitter	10.5 ... 45 V DC 10.5 ... 30 V DC in intrinsically-safe mode	Supplied through bus -
Separate 24 V power supply necessary	-	No
Bus voltage		
• Not Ex	-	9 ...32 V
• With intrinsically-safe operation	-	9 ...24 V
Current consumption		
• Basic current (max.)	-	12.5 mA
• Startup current ≤ basic current	-	Yes
• Max. current in event of fault	-	15.5 mA
Fault disconnection electronics (FDE) available	-	Yes

SITRANS P measuring instruments for pressure

Transmitters for gage, absolute and differential pressure, flow and level

DS III series for absolute pressure
(from differential pressure series)

2

SITRANS P, DS III series for absolute pressure (from differential pressure series)

	HART	PROFIBUS PA or FOUNDATION Fieldbus
Certificate and approvals		
Classification according to pressure equipment directive (DRGL 97/23/EC)	For gases of fluid group 1 and liquids of fluid group 1; complies with requirements of Article 3, paragraph 3 (sound engineering practice)	
Explosion protection		
• Intrinsic safety "i"	PTB 99 ATEX 2122	
- Identification	Ex II 1/2 G EEx ia/ib IIB/IIC T6	
- Permissible ambient temperature	-40 ... +85 °C (-40 ... +185 °F) temperature class T4; -40 ... +70 °C (-40 ... +158 °F) temperature class T5; -40 ... +60 °C (-40 ... +140 °F) temperature class T6	
- Connection	To certified intrinsically-safe circuits with maximum values: $U_i = 30 \text{ V}$, $I_i = 100 \text{ mA}$, $P_i = 750 \text{ mW}$; $R_i = 300 \Omega$	FISCO supply unit: $U_o = 17.5 \text{ V}$, $I_o = 380 \text{ mA}$, $P_o = 5.32 \text{ W}$ Linear barrier: $U_o = 24 \text{ V}$, $I_o = 250 \text{ mA}$, $P_o = 1.2 \text{ W}$
- Effective internal inductance/capacitance	$L_i = 0.4 \text{ mH}$, $C_i = 6 \text{ nF}$	$L_i = 7 \mu\text{H}$, $C_i = 1.1 \text{ nF}$
• Explosion-proof "d"	PTB 99 ATEX 1160	
- Identification	Ex II 1/2 G EEx d IIC T4/T6	
- Permissible ambient temperature	-40 ... +85 °C (-40 ... +185 °F) temperature class T4; -40 ... +60 °C (-40 ... +140 °F) temperature class T6	
- Connection	To circuits with values: $U_H = 10.5 \dots 45 \text{ V DC}$	To circuits with values: $U_H = 9 \dots 32 \text{ V DC}$
• Dust explosion protection for zone 20	PTB 01 ATEX 2055	
- Identification	Ex II 1 D IP65 T 120 °C Ex II 1/2 D IP65 T 120 °C	
- Permissible ambient temperature	-40 ... +85 °C (-40 ... +185 °F)	
- Max. surface temperature	120 °C (248 °F)	
- Connection	To certified intrinsically-safe circuits with maximum values: $U_i = 30 \text{ V}$, $I_i = 100 \text{ mA}$, $P_i = 750 \text{ mW}$, $R_i = 300 \Omega$	FISCO supply unit: $U_o = 17.5 \text{ V}$, $I_o = 380 \text{ mA}$, $P_o = 5.32 \text{ W}$ Linear barrier: $U_o = 24 \text{ V}$, $I_o = 250 \text{ mA}$, $P_o = 1.2 \text{ W}$
- Effective internal inductance/capacitance	$L_i = 0.4 \text{ mH}$, $C_i = 6 \text{ nF}$	$L_i = 7 \mu\text{H}$, $C_i = 1.1 \text{ nF}$
• Dust explosion protection for zone 21/22	PTB 01 ATEX 2055	
- Identification	Ex II 2 D IP65 T 120 °C	
- Connection	To circuits with values: $U_H = 10.5 \dots 45 \text{ V DC}$; $P_{\text{max}} = 1.2 \text{ W}$	To circuits with values: $U_H = 9 \dots 32 \text{ V DC}$; $P_{\text{max}} = 1.2 \text{ W}$
• Type of protection "n" (zone 2)	TÜV 01 ATEX 1696 X	Planned
- Identification	Ex II 3 G EEx nA L IIC T4/T5/T6	-
• Explosion protection to FM	Certificate of Compliance 3008490	
- Identification (XP/DIP) or (IS); (NI)	CL I, DIV 1, GP ABCD T4...T6; CL II, DIV 1, GP EFG; CL III; CL I, ZN 0/1 AEx ia IIC T4...T6; CL I, DIV 2, GP ABCD T4...T6; CL II, DIV 2, GP FG; CL III	
• Explosion protection to CSA	Certificate of Compliance 1153651	
- Identification (XP/DIP) or (IS)	CL I, DIV 1, GP ABCD T4...T6; CL II, DIV 1, GP EFG; CL III; Ex ia IIC T4...T6; CL I, DIV 2, GP ABCD T4...T6; CL II, DIV 2, GP FG; CL III	

SITRANS P measuring instruments for pressure

Transmitters for gage, absolute and differential pressure, flow and level

DS III series for absolute pressure (from differential pressure series)

2

HART communication

HART communication	230 ... 1100 Ω
Protocol	HART Version 5.x
Software for computer	SIMATIC PDM

PROFIBUS PA communication

Simultaneous communication with master class 2 (max.)	4
The address can be set using	Configuration tool or local operation (standard setting address 126)
Cyclic data usage	
• Output byte	5 (one measuring value) or 10 (two measuring values)
• Input byte	0, 1, or 2 (register operating mode and reset function for metering)
Internal preprocessing	
Device profile	PROFIBUS PA Profile for Process Control Devices Version 3.0, Class B
Function blocks	2
• Analog input	
- Adaptation to customer-specific process variables	Yes, linearly rising or falling characteristic
- Electrical damping T_{63} , adjustable	0 ... 100 s
- Simulation function	Input /Output
- Failure mode	Can be parameterized (last good value, substitute value, incorrect value)
- Limit monitoring	Yes, one upper and lower warning limit and one alarm limit respectively
• Register (totalizer)	Can be reset, preset, optional direction of counting, simulation function of register output
- Failure mode	Can be parameterized (summation with last good value, continuous summation, summation with incorrect value)
- Limit monitoring	One upper and lower warning limit and one alarm limit respectively
• Physical block	1
Transducer blocks	2
• Pressure transducer block	
- Can be calibrated by applying two pressures	Yes
- Monitoring of sensor limits	Yes
- Specification of a container characteristic with	Max. 30 nodes
- Square-rooted characteristic for flow measurement	Yes
- Gradual volume suppression and implementation point of square-root extraction	Parameterizable
- Simulation function for measured pressure value and sensor temperature	Constant value or over parameterizable ramp function

Communication FOUNDATION Fieldbus

Function blocks	3 function blocks analog input, 1 function block PID
• Analog input	
- Adaptation to customer-specific process variables	Yes, linearly rising or falling characteristic
- Electrical damping T_{63} , adjustable	0 ... 100 s
- Simulation function	Output/input (can be locked within the device with a bridge)
- Failure mode	Can be parameterized (last good value, substitute value, incorrect value)
- Limit monitoring	Yes, one upper and lower warning limit and one alarm limit respectively
- Square-rooted characteristic for flow measurement	Yes
• PID	Standard FF function block
• Physical block	1 Resource block
Transducer blocks	1 transducer block Pressure with calibration, 1 transducer block LCD
• Pressure transducer block	
- Can be calibrated by applying two pressures	Yes
- Monitoring of sensor limits	Yes
- Simulation function: Measured pressure value, sensor temperature and electronics temperature	Constant value or over parameterizable ramp function

SITRANS P measuring instruments for pressure

Transmitters for gage, absolute and differential pressure, flow and level

**DS III series for absolute pressure
(from differential pressure series)**

2

Selection and Ordering data		Order No.	
SITRANS P pressure transmitters for absolute pressure, from the differential pressure, series DS III HART		7 MF 4 3 3 3 -	
Measuring cell filling	Measuring cell cleaning		
Silicone oil	Standard	1	
Inert liquid ¹⁾	Grease-free	3	
Span			
8.3 ... 250 mbar a	(0.12 ... 3.63 psi a)	E)	D
43 ... 1300 mbar a	(0.62 ... 18.9 psi a)	E)	F
0.16 ... 5 bar a	(2.32 ... 72.5 psi a)	E)	G
1 ... 30 bar a	(14.5 ... 435 psi a)		H
5.3 ... 100 bar a	(76.9 ... 1450 psi a)		KE
Wetted parts materials			
Seal diaphragm	Parts of measuring cell		
Stainless steel	Stainless steel		A
Hastelloy	Stainless steel		B
Hastelloy	Hastelloy		C
Tantalum	Tantalum		E
Monel	Monel	E)	H
Gold	Gold		L
Version for diaphragm seal ²⁾³⁾⁴⁾			Y
Process connection			
Female thread 1/4-18 NPT with flange connection			
• Sealing screw opposite process connection			
- Mounting thread M10 to DIN 19213			0
- Mounting thread 7/16-20 UNF to EN 61518			2
• Vent on side of process flange ⁵⁾			
- Mounting thread M10 to DIN 19213			4
- Mounting thread 7/16-20 UNF to EN 61518			6
Non-wetted parts materials			
Process flange screws	Electronics housing		
Stainless steel	Die-cast aluminium		2
Stainless steel	Stainless steel precision casting ⁶⁾		3
Version			
• Standard version			1
• International version, English label inscriptions, documentation in 5 languages on CD			2
Explosion protection			
• Without			A
• With ATEX, Type of protection:			
- "Intrinsic safety (EEx ia)"			B
- "Explosion-proof (EEx d)" ⁷⁾			D
- "Intrinsic safety and explosion-proof enclosure (EEx ia + EEx d)" ⁸⁾			P
- "Ex nA/nL (zone 2)"			E
- "Intrinsic safety, explosion-proof enclosure and dust explosion protection (EEx ia + EEx d + Zone 1D/2D)" ⁸⁾			R
• With FM + CSA, Type of protection:			
- "Intrinsic safety and explosion-proof (is + xp)" ⁷⁾			NC
Electrical connection / cable entry			
• Screwed gland Pg 13.5 ⁹⁾			A
• Screwed gland M20x1.5			B
• Screwed gland 1/2-14 NPT			C
• Han 7D plug (plastic housing) incl. mating connector ⁹⁾			D
• Plug M12 (metal) ¹⁰⁾			F

Selection and Ordering data		Order No.	
SITRANS P pressure transmitters for absolute pressure, from the differential pressure, series DS III HART		7 MF 4 3 3 3 -	
Display			
• Without (digital indicator hidden, setting: mA)			1
• With visible digital indicator			6
• With customer-specific digital indicator (setting as specified, Order code "Y21" or required)			7
Power supply units see "SITRANS I power supply units and isolation amplifiers".			
Factory-mounting of shut-off valves and valve manifolds see page 2/133.			
Included in delivery of the device:			
• Brief instructions (Leporello)			
• CD-ROM with detailed documentation			
• Sealing plug(s) or sealing screw(s) for the process flanges(s)			
1) For oxygen applications, add Order code E10.			
2) Version 7MF4333-1DY... only up to max. span 200 mbar a (2.9 psi a).			
3) When the manufacturer's certificate M (calibration certificate) has to be ordered for transmitters with diaphragm seals, it is recommended only to order this certificate exclusively with the diaphragm seals. The measuring accuracy of the <u>total</u> combination is certified here.			
4) When the acceptance test certificate 3.1 for transmitters with direct-connected diaphragm seals is ordered, this certificate must also be ordered with the corresponding seals.			
5) Not for span "5.3 ... 100 bar a (76.9 ... 1450 psi a)". Position of the top vent valve in the process flange (see dimensional drawing).			
6) Not together with Electrical connection „Screwed gland Pg 13.5" and „Han7D plug".			
7) Without cable gland, with blanking plug			
8) With enclosed cable gland EEx ia and blanking plug			
9) Not together with type of protection "Explosion-proof" and type of protection "Ex nA".			
10) Not together with types of protection "Explosion-proof" or "Intrinsic safety and explosion-proof"			
E) Combinations of the versions marked with E) are subject to the export regulations AL: 2B230, ECCN: N.			
F) Subject to export regulations AL: 91999, ECCN: N.			

SITRANS P measuring instruments for pressure

Transmitters for gage, absolute and differential pressure, flow and level

DS III series for absolute pressure (from differential pressure series)

2

Selection and Ordering data		Order No.	
SITRANS P pressure transmitters for absolute pressure (from the differential pressure series)			
DS III PA series (PROFIBUS PA)	F)	7 MF 4 3 3 4 -	
DS III FF series (FOUNDATION Fieldbus)	F)	7 MF 4 3 3 5 -	
Measuring cell filling		Measuring cell cleaning	
Silicone oil		Standard	1
Inert liquid ¹⁾		Grease-free	3
Nominal measuring range			
250 mbar a	(3.63 psi a)	E)	D
1300 mbar a	(18.9 psi a)	E)	F
5 bar a	(72.5 psi a)	E)	G
30 bar a	(435 psi a)		H
100 bar a	(1450 psi a)		K E
Wetted parts materials			
Seal diaphragm	Parts of measuring cell		
Stainless steel	Stainless steel		A
Hastelloy	Stainless steel		B
Hastelloy	Hastelloy		C
Tantalum	Tantalum		E
Monel	Monel	E)	H
Gold	Gold		L
Version as diaphragm seal ²⁾³⁾⁴⁾			Y
Process connection			
Female thread 1/4-18 NPT with flange connection			
• Sealing screw opposite process connection			
- Mounting thread M10 to DIN 19213			0
- Mounting thread 7/16-20 UNF to EN 61518			2
• Vent on side of process flange ⁵⁾			
- Mounting thread M10 to DIN 19213			4
- Mounting thread 7/16-20 UNF to EN 61518			6
Non-wetted parts materials			
Process flange screws	Electronics housing		
Stainless steel	Die-cast aluminium		2
Stainless steel	Stainless steel precision casting		3
Version			
• Standard version			1
• International version, English label inscriptions, documentation in 5 languages on CD			2
Explosion protection			
• Without			A
• With CENELEC, Type of protection:			
- "Intrinsic safety (EEx ia)"			B
- "Explosion-proof (EEx d)" ⁶⁾			D
- "Intrinsic safety and explosion-proof enclosure (EEx ia + EEx d)" ⁷⁾			P
- "Ex nA/nL (zone 2)"			E
- "Intrinsic safety, explosion-proof enclosure and dust explosion protection (EEx ia + EEx d + Zone 1D/2D)" ⁷⁾ (not for DS III FF)			R
• With FM + CSA, Type of protection:			
- "Intrinsic safety and explosion-proof (is + xp)" ⁶⁾			NC
Electrical connection / cable entry			
• Screwed gland M20x1.5			B
• Screwed gland 1/2-14 NPT			C
• M12 Connector (metall) ⁸⁾			F

Selection and Ordering data		Order No.	
SITRANS P pressure transmitters for absolute pressure (from the differential pressure series)			
DS III PA series (PROFIBUS PA)	F)	7 MF 4 3 3 4 -	
DS III FF series (FOUNDATION Fieldbus)	F)	7 MF 4 3 3 5 -	
Display			
• Without (digital display hidden)			1
• With visible digital indicator			6
• With customer-specific digital indicator (setting as specified, Order code "Y21" or required)			7
Factory-mounting of shut-off valves and valve manifolds see page 2/133.			
Included in delivery of the device:			
• Brief instructions (Leporello)			
• CD-ROM with detailed documentation			
• Sealing plug(s) or sealing screw(s) for the process flanges(s)			
1) For oxygen application, add Order code E10.			
2) Version 7MF4334-1DY... only up to max. span 200 mbar a (2.9 psi a).			
3) When the manufacturer's certificate M (calibration certificate) has to be ordered for transmitters with diaphragm seals, it is recommended only to order this certificate exclusively with the diaphragm seals. The measuring accuracy of the total combination is certified here.			
4) When the acceptance test certificate 3.1 for transmitters with direct-connected diaphragm seals is ordered, this certificate must also be ordered with the corresponding seals.			
5) Not for nominal measuring range 100 bar a (1450 psi a). Position of the top vent valve in the process flange (see dimensional drawing).			
6) Without cable gland, with blanking plug			
7) With enclosed cable gland EEx ia and blanking plug			
8) Cannot be used together with the following types of protection: "Explosion-proof" and "Intrinsic safety and explosion-proof".			
E) Combinations of the versions marked with E) are subject to the export regulations AL: 2B230, ECCN: N.			
F) Subject to export regulations AL: 9I999, ECCN: N.			

SITRANS P measuring instruments for pressure

Transmitters for gage, absolute and differential pressure, flow and level

**DS III series for absolute pressure
(from differential pressure series)**

2

Selection and Ordering data	Order code		
<i>Further designs</i>	HART	PA	FF
Add "-Z" to Order No. and specify Order code.			
Pressure transmitter with mounting bracket made of:			
• Steel	A01	✓	✓
• Stainless steel	A02	✓	✓
O-rings for process flanges (instead of FPM (Viton))			
• PTFE (Teflon)	A20	✓	✓
• FEP (with silicone core, approved for food)	A21	✓	✓
• FFFM (Kalrez, compound 4079)	A22	✓	✓
• NBR (Buna N)	A23	✓	✓
Plug			
• Han 7D (metal, gray)	A30	✓	
• Han 8U (instead of Han 7D)	A31	✓	
Sealing screws	A40	✓	✓
1/4-18 NPT, with valve in material of process flanges			
Cable sockets for M12 connectors (metal)	A50	✓	✓
Rating plate inscription (instead of German)			
• English	B11	✓	✓
• French	B12	✓	✓
• Spanish	B13	✓	✓
• Italian	B14	✓	✓
English rating plate Pressure units in inH ₂ O or psi	B21	✓	✓
Manufacturer's test certificate M (calibration certificate)¹⁾ To DIN 55350, Part 18 and to ISO 8402	C11	✓	✓
Acceptance test certificate²⁾ To EN 10204-3.1	C12	✓	✓
Factory certificate To EN 10204-2.2	C14	✓	✓
"Functional Safety (SIL)" certificate	C20	✓	
"PROFIsafe" certificate and protocol	C21		✓
Setting of upper limit of output signal to 22.0 mA	D05	✓	
Manufacturer's declaration acc. to NACE (only together with seal diaphragm made of Hastelloy and stainless steel)	D07	✓	✓
Type of protection IP68 (not together with Han 7D/Han 8U plug, cable gland PG 13.5)	D12	✓	✓
Digital indicator alongside the input keys (only together with the devices 7MF4333-...-2-.A.6 or -.A.7-Z, Y21 or Y22 + Y01)	D27	✓	✓
Supplied with oval flange (1 item), PTFE packing and stainless steel screws in thread of process flange	D37	✓	✓
Use in or on zone 1D/2D (only together with type of protection "Intrinsic safety (EEx ia)")	E01	✓	✓
Use on zone 0 (only together with type of protection "Intrinsic safety (EEx ia)")	E02	✓	✓
Oxygen application (max. 160 bar a (2320 psi a) with oxygen measurement and inert liquid)	E10	✓	✓
Explosion-proof "Intrinsic safety" to INMETRO (Brazil) (only for transmitter 7MF4...-.....-B..)	E25	✓	✓

Selection and Ordering data	Order code		
<i>Further designs</i>	HART	PA	FF
Add "-Z" to Order No. and specify Order code.			
Explosion-proof "Intrinsic safety" to NEPSI (China) (only for transmitter 7MF4...-.....-B..)	E55	✓	✓
Explosion protection "Explosion-proof" to NEPSI (China) (only for transmitter 7MF4...-.....-D..)	E56	✓	✓
Explosion-proof "Zone 2" to NEPSI (China) (only for transmitter 7MF4...-.....-E..)	E57	✓	✓
Interchanging of process connection side	H01	✓	✓
Vent on side for gas measurements	H02	✓	✓
Process flange			
• Hastelloy	K01	✓	✓
• Monel	K02	✓	✓
• Stainless steel with PVDF insert max. PN 10 (MWP 145 psi), max. temperature of medium 90 °C (194 °F)	K04	✓	✓
For 1/2-14 NPT inner process connection on the side in the middle of the process flange, vent valve not possible			
Additional data			
Add "-Z" to Order No. and specify Order code.			
Measuring range to be set Specify in plain text (max. 5 digits): Y01: ... up to ... mbar, bar, kPa, MPa, psi	Y01	✓	
Measuring point number (TAG No.) Max. 16 characters, specify in plain text: Y15:	Y15	✓	✓
Measuring point text Max. 27 characters, specify in plain text: Y16:	Y16	✓	✓
Entry of HART address (TAG) Max. 8 characters, specify in plain text: Y17:	Y17	✓	
Setting of pressure indication in pressure units Specify in plain text (standard setting: mA): Y21: mbar, bar, kPa, MPa, psi, ... Note: The following pressure units can be selected: bar, mbar, mm H ₂ O ¹⁾ , inH ₂ O ¹⁾ , ftH ₂ O ¹⁾ , mmHG, inHG, psi, Pa, kPa, MPa, g/cm ² , kg/cm ² , Torr, ATM oder %) ref. temperature 20 °C	Y21	✓	✓
Setting of pressure indication in non-pressure units Specify in plain text: Y22: up to l/min, m ³ /h, m, USgpm, ... (specification of measuring range in pressure units "Y01" is essential, unit with max. 5 characters)	Y22 + Y01	✓	
Preset bus address Specify in plain text: Y25:	Y25		✓

Only "Y01", "Y21", "Y22", "Y25" and "D05" can be factory preset

✓ = available

1) When the manufacturer's certificate M (calibration certificate) has to be ordered for transmitters with diaphragm seals, it is recommended only to order this certificate exclusively with the diaphragm seals. The measuring accuracy of the total combination is certified here.

2) When the acceptance test certificate 3.1 for transmitters with direct-connected diaphragm seals is ordered, this certificate must also be ordered with the corresponding seals.

SITRANS P measuring instruments for pressure

Transmitters for gage, absolute and differential pressure, flow and level

DS III series for absolute pressure
(from differential pressure series)

Dimensional drawings

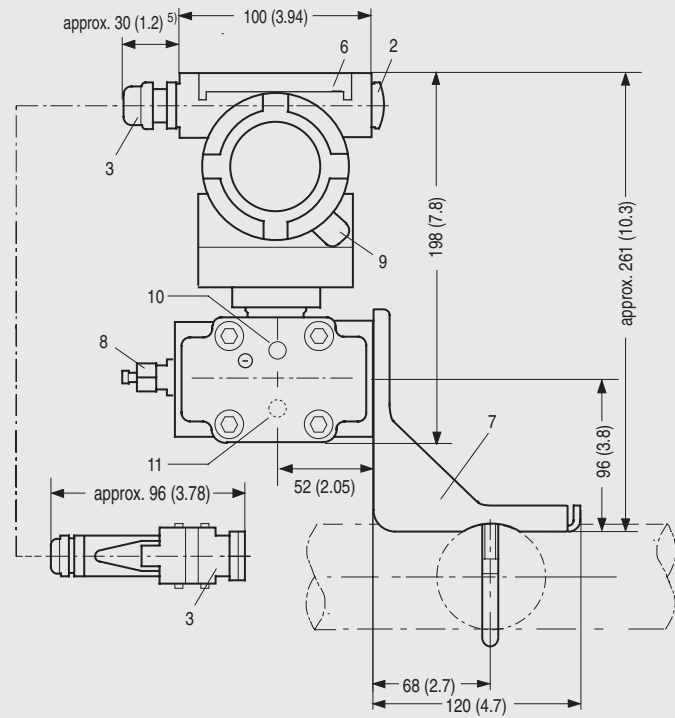
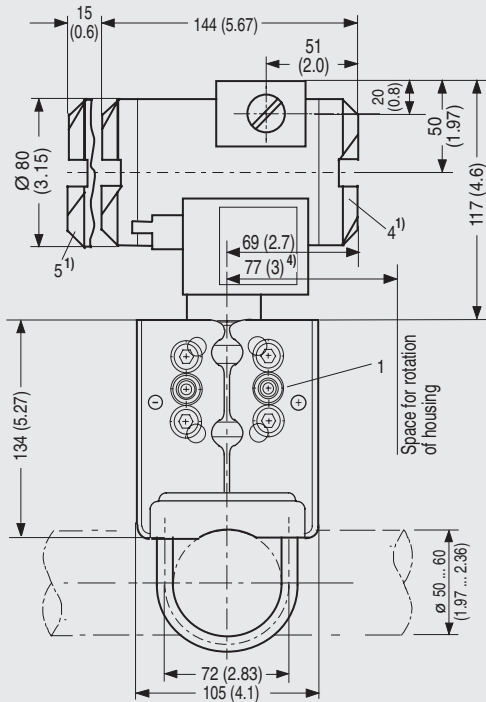

- 1 Process connection: 1/4-18 NPT (EN 61518)
- 2 Blanking plug
- 3 Electrical connection:
 - screwed gland Pg 13,5 (adapter)^{2) 3)},
 - screwed gland M20x1,5³⁾,
 - screwed gland 1/2-14 NPT or
 - Han 7D/ Han 8U plug^{2) 3)}
- 4 Terminal side
- 5 Electronics side, digital display (longer overall length for cover with window)
- 6 Protective cover over keys
- 7 Mounting bracket (option)
- 8 Sealing screw with valve (option)
- 9 Screw cover - safety bracket (only for type of protection "Explosion-proof enclosure", not shown in the drawing)
- 10 Lateral venting for liquid measurement (Standard)
- 11 Lateral venting for gas measurement (suffix H02)

- 1) Allow approx. 20 mm (0.79 inch) thread length to permit unscrewing
- 2) Not with type of protection "explosion-proof enclosure"
- 3) Not with type of protection "FM + CSA [is + xp]"
- 4) 92 mm (3.62 inch) for minimum distance to permit rotation with indicator
- 5) 45 mm (1.8 inch) for Pg 13,5 with adapter

SITRANS P pressure transmitters, DS III HART series for absolute pressure, from the differential pressure series, dimensions in mm (inch)

SITRANS P measuring instruments for pressure

Transmitters for gage, absolute and differential pressure, flow and level

DS III series for absolute pressure
(from differential pressure series)

2

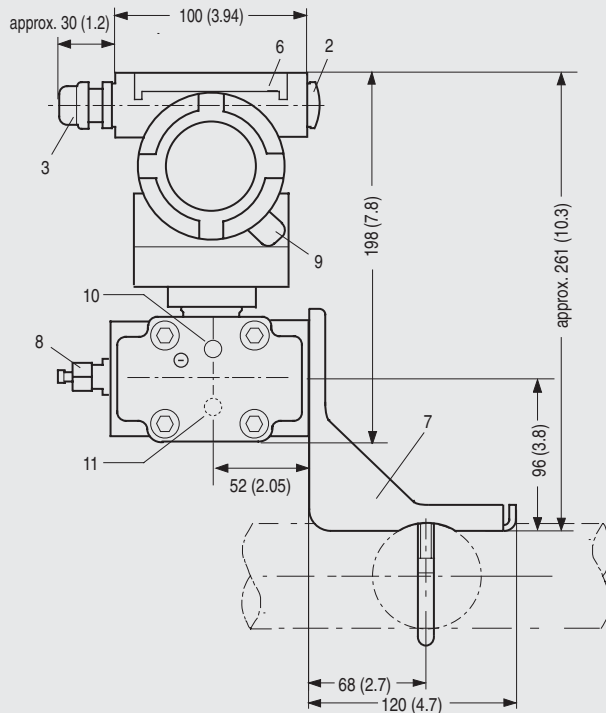
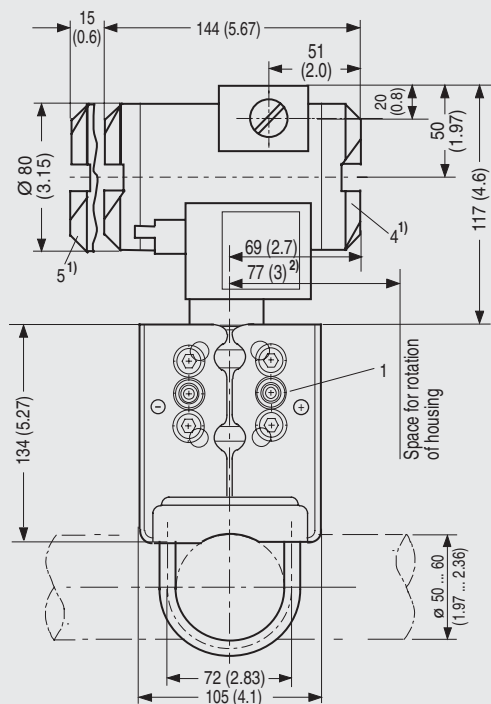

- 1 Process connection: 1/4-18 NPT (EN 61518)
- 2 Blanking plug
- 3 Electrical connection:
 - screwed gland M20x1,5⁴⁾,
 - screwed gland 1/2-14 NPT or
 - PROFIBUS plug M12^{3) 4)}
- 4 Terminal side
- 5 Electronic side, digital display (longer overall length for cover with window)
- 6 Protective cover over keys
- 7 Mounting bracket (option)
- 8 Sealing screw with valve (option)
- 9 Screw cover – safety bracket (only for explosion-proof enclosure, not shown in the drawing)
- 10 Lateral venting for liquid measurement (Standard)
- 11 Lateral venting for gas measurement (suffix H02)

- 1) Allow approx. 20 mm (0.79 inch) thread length in addition
- 2) 92 mm (3.62 inch) for minimum distance to permit rotation with indicator
- 3) Not with type of protection "explosion-proof enclosure"
- 4) Not with type of protection "FM + CSA"

SITRANS P pressure transmitters, DS III PA and FF series for absolute pressure, from the differential pressure series, dimensions in mm (inch)

SITRANS P measuring instruments for pressure

Transmitters for gage, absolute and differential pressure, flow and level

DS III series for differential pressure and flow

Technical specifications

SITRANS P, DS III series, for differential pressure and flow

	HART	PROFIBUS PA or FOUNDATION Fieldbus
Input	Differential pressure and flow	
Measured variable	Span	
Spans (infinitely adjustable) or nominal measuring range and max. permissible working pressure	1 ... 20 mbar (0.4015 ... 8.031 inH ₂ O)	Maximum working pressure 32 bar (464 psi)
	1 ... 60 mbar (0.4015 ... 24.09 inH ₂ O)	20 mbar g (8.031 inH ₂ O)
	2.5 ... 250 mbar (1.004 ... 100.4 inH ₂ O)	Maximum working pressure 160 bar (2320 psi)
	6 ... 600 mbar (2.409 ... 240.9 inH ₂ O)	60 mbar (24.09 inH ₂ O)
	16 ... 1600 mbar (6.424 ... 642.4 inH ₂ O)	250 mbar (100.4 inH ₂ O)
	50 ... 5000 mbar (20.08 ... 2008 inH ₂ O)	600 mbar (240.9 inH ₂ O)
	0.3 ... 30 bar (4.35 ... 435 psi)	1600 mbar (642.4 inH ₂ O)
		5 bar (2008 inH ₂ O)
		30 bar (435 psi)
	2.5 ... 250 mbar (1.004 ... 100.4 inH ₂ O)	420 bar (6091 psi)
	6 ... 600 mbar (2.409 ... 240.9 inH ₂ O)	250 mbar (100.4 inH ₂ O)
	16 ... 1600 mbar (6.424 ... 642.4 inH ₂ O)	600 mbar (240.9 inH ₂ O)
	50 ... 5000 mbar (20.08 ... 2008 inH ₂ O)	1600 mbar (642.4 inH ₂ O)
	0.3 ... 30 bar (4.35 ... 435 psi)	5 bar (2008 inH ₂ O)
		30 bar (435 psi)
Lower measuring limit	-100% of max. span (-33% with 30 bar (435 psi) measuring cell or 30 mbar a (0.44 psi))	
Upper measuring limit	100% of max. span (for oxygen version and inert filling liquid; max. 160 bar g (2320 psi g))	
Output	4 ... 20 mA	
Output signal	Digital PROFIBUS PA or FOUNDATION Fieldbus signal	
• Lower limit (infinitely adjustable) • Upper limit (infinitely adjustable)	3.55 mA, factory preset to 3.84 mA	-
	23 mA, factory preset to 20.5 mA or optionally set to 22.0 mA	-
Load	-	
• Without HART communication	$R_B \leq (U_H - 10.5 \text{ V})/0.023 \text{ A}$ in Ω , U_H : Power supply in V	-
• With HART communication	$R_B = 230 \dots 500 \Omega$ (SIMATIC PDM) or $R_B = 230 \dots 1100 \Omega$ (HART Communicator)	-
Physical bus	-	
With polarity reversal protection	IEC 61158-2 Yes	
Accuracy	To EN 60770-1	
Reference conditions	Increasing characteristic, start-of-scale value 0 bar, stainless steel seal diaphragm, silicone oil filling, room temperature 25 °C (77 °F) r: Span ratio (r = max. span / set span)	
Error in measurement and fixed-point setting (including hysteresis and repeatability)		
• Linear characteristic	≤ 0,075%	
- r ≤ 10	≤ (0.0029 · r + 0.071)%	
- 10 < r ≤ 30	≤ (0.0045 · r + 0.071)%	
- 30 < r ≤ 100	≤ (0.005 · r + 0.05)%	
• Square-root characteristic (flow > 50%)	≤ 0,1%	
- r ≤ 10	≤ 0,1%	
- 10 < r ≤ 30	≤ 0,2%	

SITRANS P measuring instruments for pressure

Transmitters for gage, absolute and differential pressure, flow and level

DS III series
for differential pressure and flow

2

SITRANS P, DS III series, for differential pressure and flow

	HART	PROFIBUS PA or FOUNDATION Fieldbus
<ul style="list-style-type: none"> • Square-root characteristic (flow 25 ... 50%) <ul style="list-style-type: none"> - $r \leq 10$ - $10 < r \leq 30$ Long-term drift (temperature change ± 30 °C (± 54 °F)) <ul style="list-style-type: none"> • 20 mbar (0.29 psi)-measuring cell Influence of ambient temperature <ul style="list-style-type: none"> • at $-10 \dots +60$ °C ($14 \dots 140$ °F) • at $-40 \dots -10$ °C and $+60 \dots +85$ °C ($-40 \dots +14$ °F and $140 \dots 185$ °F) Influence of static pressure <ul style="list-style-type: none"> • on the zero point <ul style="list-style-type: none"> - 20 mbar (0.29 psi)-measuring cell • on the span <ul style="list-style-type: none"> - 20 mbar (0.29 psi)-measuring cell Measured Value Resolution	$\leq 0,2\%$ $\leq 0,4\%$ $\leq (0,25 \cdot r)\%$ every 5 years static pressure max. 70 bar g (1015 psi g) $\leq (0,2 \cdot r)$ per year $\leq (0,08 \cdot r + 0,1)\%$ $\leq (0,1 \cdot r + 0,15)\%/10$ K (Twice the value with 20-mbar (0.29 psi) measuring cell) $\leq (0,15 \cdot r)\%$ per 100 bar (1450 psi) $\leq (0,15 \cdot r)\%$ per 32 bar (464 psi) $\leq 0,2\%$ je 100 bar (1450 psi) $\leq 0,2\%$ je 32 bar (464 psi) -	$\leq 0,2$ - - $\leq (0,25\%$ every 5 years static pressure max. 70 bar g (1015 psi g) $\leq 0,2$ per year $\leq 0,3\%$ $\leq 0,25\%/10$ K $\leq 0,15\%$ je 100 bar (1450 psi) $\leq 0,15\%$ je 32 bar (464 psi) - - $3 \cdot 10^{-5}$ of nominal measuring range
Rated operating conditions Degree of protection (to EN 60529) Process temperature <ul style="list-style-type: none"> • Measuring cell with silicone oil filling • Measuring cell with inert filling liquid • In conjunction with dust explosion protection Ambient conditions <ul style="list-style-type: none"> • Ambient temperature <ul style="list-style-type: none"> - Digital indicators • Storage temperature • Climatic class <ul style="list-style-type: none"> - Condensation • Electromagnetic compatibility <ul style="list-style-type: none"> - Emitted interference and interference immunity 	IP65 $-40 \dots +100$ °C ($-40 \dots +212$ °F) $-20 \dots +100$ °C ($-4 \dots +212$ °F) $-20 \dots +60$ °C ($-4 \dots +140$ °F) $-30 \dots +85$ °C ($-22 \dots +185$ °F) $-50 \dots +85$ °C ($-58 \dots +185$ °F) Permissible To EN 61326 and NAMUR NE 21	
Design Weight (without options) Housing material Wetted parts materials <ul style="list-style-type: none"> • Seal diaphragm Measuring cell filling Process connection	$\approx 4,5$ kg ($\approx 9,9$ lb) Poor in copper die-cast aluminium, GD-AISI12 or stainless steel precision casting, mat. No. 1.4408 Stainless steel, mat. No. 1.4404/316L or Hastelloy C276, mat. No. 2.4819, Monel, mat. No. 2.4360, tantalum or gold Silicone oil or inert filling liquid (max. 160 bar (2320 psi g) with oxygen measurement) Female thread $\frac{1}{4}$ -18 NPT and flange connection with mounting thread M10 to DIN 19213 or $\frac{7}{16}$ -20 UNF to EN 61518	
Power supply U_H Terminal voltage on transmitter Separate 24 V power supply necessary Bus voltage <ul style="list-style-type: none"> • Not Ex • With intrinsically-safe operation Current consumption <ul style="list-style-type: none"> • Basic current (max.) • Startup current \leq basic current • Max. current in event of fault Fault disconnection electronics (FDE) avail.	10.5 ... 45 V DC 10.5 ... 30 V DC in intrinsically-safe mode - - - - - - - - - -	Supplied through bus - No $9 \dots 32$ V $9 \dots 24$ V $12,5$ mA Yes $15,5$ mA Yes

SITRANS P measuring instruments for pressure

Transmitters for gage, absolute and differential pressure, flow and level

DS III series for differential pressure and flow

2

SITRANS P, DS III series, for differential pressure and flow

	HART	PROFIBUS PA or FOUNDATION Fieldbus
Certificate and approvals		
Classification according to pressure equipment directive (DRGL 97/23/EC)		
PN 32/160 (MWP 464/2320 psi)	For gases of fluid group 1 and liquids of fluid group 1; complies with requirements of Article 3, paragraph 3 (sound engineering practice)	
PN 420 (MWP 6092 psi)	For gases of fluid group 1 and liquids of fluid group 1; complies with basic safety requirements of Article 3, paragraph 1 (appendix 1); assigned to category III, conformity evaluation module H by the TÜV Nord.	
Explosion protection		
• Intrinsic safety "i"	PTB 99 ATEX 2122	
- Identification	Ex II 1/2 G EEx ia/ib IIB/IIC T6	
- Permissible ambient temperature	-40 ... +85 °C (-40 ... +185 °F) temperature class T4; -40 ... +70 °C (-40 ... +158 °F) temperature class T5; -40 ... +60 °C (-40 ... +140 °F) temperature class T6	
- Connection	To certified intrinsically-safe circuits with maximum values: $U_i = 30 \text{ V}$, $I_i = 100 \text{ mA}$, $P_i = 750 \text{ mW}$; $R_i = 300 \Omega$	FISCO supply unit: $U_o = 17.5 \text{ V}$, $I_o = 380 \text{ mA}$, $P_o = 5.32 \text{ W}$ Linear barrier: $U_o = 24 \text{ V}$, $I_o = 250 \text{ mA}$, $P_o = 1.2 \text{ W}$
- Effective internal inductance/capacitance	$L_i = 0.4 \text{ mH}$, $C_i = 6 \text{ nF}$	$L_i = 7 \mu\text{H}$, $C_i = 1.1 \text{ nF}$
• Explosion-proof "d"	PTB 99 ATEX 1160	
- Identification	Ex II 1/2 G EEx d IIC T4/T6	
- Permissible ambient temperature	-40 ... +85 °C (-40 ... +185 °F) temperature class T4; -40 ... +60 °C (-40 ... +140 °F) temperature class T6	
- Connection	To circuits with values: $U_H = 10.5 \dots 45 \text{ V DC}$	To circuits with values: $U_H = 9 \dots 32 \text{ V DC}$
• Dust explosion protection for zone 20	PTB 01 ATEX 2055	
- Identification	Ex II 1 D IP65 T 120 °C Ex II 1/2 D IP65 T 120 °C	
- Permissible ambient temperature	-40 ... +85 °C (-40 ... +185 °F)	
- Max. surface temperature	120 °C (248 °F)	
- Connection	To certified intrinsically-safe circuits with maximum values: $U_i = 30 \text{ V}$, $I_i = 100 \text{ mA}$, $P_i = 750 \text{ mW}$, $R_i = 300 \Omega$	FISCO supply unit: $U_o = 17.5 \text{ V}$, $I_o = 380 \text{ mA}$, $P_o = 5.32 \text{ W}$ Linear barrier: $U_o = 24 \text{ V}$, $I_o = 250 \text{ mA}$, $P_o = 1.2 \text{ W}$
- Effective internal inductance/capacitance	$L_i = 0.4 \text{ mH}$, $C_i = 6 \text{ nF}$	$L_i = 7 \mu\text{H}$, $C_i = 1.1 \text{ nF}$
• Dust explosion protection for zone 21/22	PTB 01 ATEX 2055	
- Identification	Ex II 2 D IP65 T 120 °C	
- Connection	To circuits with values: $U_H = 10.5 \dots 45 \text{ V DC}$; $P_{\max} = 1.2 \text{ W}$	To circuits with values: $U_H = 9 \dots 32 \text{ V DC}$; $P_{\max} = 1.2 \text{ W}$
• Type of protection "n" (zone 2)	TÜV 01 ATEX 1696 X	Planned
- Identification	Ex II 3 G EEx nA L IIC T4/T5/T6	-
• Explosion protection to FM	Certificate of Compliance 3008490	
- Identification (XP/DIP) or (IS); (NI)	CL I, DIV 1, GP ABCD T4...T6; CL II, DIV 1, GP EFG; CL III; CL I, ZN 0/1 AEx ia IIC T4...T6; CL I, DIV 2, GP ABCD T4...T6; CL II, DIV 2, GP FG; CL III	
• Explosion protection to CSA	Certificate of Compliance 1153651	
- Identification (XP/DIP) or (IS)	CL I, DIV 1, GP ABCD T4...T6; CL II, DIV 1, GP EFG; CL III; Ex ia IIC T4...T6; CL I, DIV 2, GP ABCD T4...T6; CL II, DIV 2, GP FG; CL III	

SITRANS P measuring instruments for pressure

Transmitters for gage, absolute and differential pressure, flow and level

DS III series
for differential pressure and flow

2

HART communication

HART communication	230 ... 1100 Ω
Protocol	HART Version 5.x
Software for computer	SIMATIC PDM

PROFIBUS PA communication

Simultaneous communication with master class 2 (max.)	4
The address can be set using	Configuration tool or local operation (standard setting address 126)
Cyclic data usage	
• Output byte	5 (one measuring value) or 10 (two measuring values)
• Input byte	0, 1, or 2 (register operating mode and reset function for metering)
Internal preprocessing	
Device profile	PROFIBUS PA Profile for Process Control Devices Version 3.0, Class B
Function blocks	2
• Analog input	
- Adaptation to customer-specific process variables	Yes, linearly rising or falling characteristic
- Electrical damping T_{63} , adjustable	0 ... 100 s
- Simulation function	Input /Output
- Failure mode	Can be parameterized (last good value, substitute value, incorrect value)
- Limit monitoring	Yes, one upper and lower warning limit and one alarm limit respectively
• Register (totalizer)	Can be reset, preset, optional direction of counting, simulation function of register output
- Failure mode	Can be parameterized (summation with last good value, continuous summation, summation with incorrect value)
- Limit monitoring	One upper and lower warning limit and one alarm limit respectively
• Physical block	1
Transducer blocks	2
• Pressure transducer block	
- Can be calibrated by applying two pressures	Yes
- Monitoring of sensor limits	Yes
- Specification of a container characteristic with	Max. 30 nodes
- Square-rooted characteristic for flow measurement	Yes
- Gradual volume suppression and implementation point of square-root extraction	Parameterizable
- Simulation function for measured pressure value and sensor temperature	Constant value or over parameterizable ramp function

Communication FOUNDATION Fieldbus

Function blocks	3 function blocks analog input, 1 function block PID
• Analog input	
- Adaptation to customer-specific process variables	Yes, linearly rising or falling characteristic
- Electrical damping T_{63} , adjustable	0 ... 100 s
- Simulation function	Output/input (can be locked within the device with a bridge)
- Failure mode	Can be parameterized (last good value, substitute value, incorrect value)
- Limit monitoring	Yes, one upper and lower warning limit and one alarm limit respectively
- Square-rooted characteristic for flow measurement	Yes
• PID	Standard FF function block
• Physical block	1 Resource block
Transducer blocks	1 transducer block Pressure with calibration, 1 transducer block LCD
• Pressure transducer block	
- Can be calibrated by applying two pressures	Yes
- Monitoring of sensor limits	Yes
- Simulation function: Measured pressure value, sensor temperature and electronics temperature	Constant value or over parameterizable ramp function

SITRANS P measuring instruments for pressure

Transmitters for gage, absolute and differential pressure, flow and level

DS III series for differential pressure and flow

2

Selection and Ordering data		Order No.
SITRANS P pressure transmitters for differential pressure and flow, Series DS III HART PN 32/160 (MWP 464/2320 psi)		7 MF 4 4 3 3 -
Measuring cell filling	Measuring cell cleaning	
Silicone oil	Standard	▶ 1
Inert liquid ¹⁾	Grease-free	▶ 3
Span		
PN 32 (MWP 464 psi)		
1 ... 20 mbar ²⁾	(0.4015 ... 8.03 inH ₂ O)	▶ B
PN 160 (MWP 2320 psi)		
1 ... 60 mbar	(0.4015 ... 24.09 inH ₂ O)	▶ C
2.5 ... 250 mbar	(1.004 ... 100.4 inH ₂ O)	▶ D
6 ... 600 mbar	(2.409 ... 240.9 inH ₂ O)	▶ E
16 ... 1600 mbar	(6.424 ... 642.4 inH ₂ O)	▶ F
50 ... 5000 mbar	(20.08 ... 2008 inH ₂ O)	▶ G
0.3 ... 30 bar	(4.35 ... 435 psi)	▶ H
Wetted parts materials (stainless steel process flanges)		
Seal diaphragm	Parts of measuring cell	
Stainless steel	Stainless steel	▶ A
Hastelloy	Stainless steel	F) B
Hastelloy	Hastelloy	F) C
Tantalum ³⁾	Tantalum	E
Monel ³⁾	Monel	F) H
Gold ³⁾	Gold	L
Version for diaphragm seal ^{4) 5)}		Y
Process connection		
Female thread 1/4-18 NPT with flange connection		
• Sealing screw opposite process connection		
- Mounting thread M10 to DIN 19213		▶ 0
- Mounting thread 7/16-20 UNF to EN 61518		▶ 2
• Vent on side of process flange ²⁾		
- Mounting thread M10 to DIN 19213		▶ 4
- Mounting thread 7/16-20 UNF to EN 61518		▶ 6
Non-wetted parts materials		
Process flange screws	Electronics housing	
Stainless steel	Die-cast aluminium	▶ 2
Stainless steel	Stainless steel precision casting ⁶⁾	▶ 3
Version		
• Standard version		▶ 1
• International version, English label inscriptions, documentation in 5 languages on CD		▶ 2
Explosion protection		
• Without		A
• With ATEX, Type of protection:		
- "Intrinsic safety (EEx ia)"		B
- "Explosion-proof (EEx d)" ⁷⁾	F)	D
- "Intrinsic safety and explosion-proof enclosure (EEx ia + EEx d)" ⁸⁾	F)	P
- "Ex nA/nL (zone 2)"		E
- "Intrinsic safety, explosion-proof enclosure and dust explosion protection (EEx ia + EEx d + Zone 1D/2D)" ⁸⁾	▶ F)	R
• With FM + CSA, Type of protection:		
- "Intrinsic safety and explosion-proof (is + xp)" ⁷⁾	F)	NC
Electrical connection / cable entry		
• Screwed gland Pg 13.5 ⁹⁾		A
• Screwed gland M20x1.5		▶ B
• Screwed gland 1/2-14 NPT		C
• Han 7D plug (plastic housing) incl. mating connector ¹⁰⁾		F) D
• M12 connectors (metal) ¹⁰⁾		F

Selection and Ordering data		Order No.
SITRANS P pressure transmitters for differential pressure and flow, Series DS III HART PN 32/160 (MWP 464/2320 psi)		7 MF 4 4 3 3 -
Display		
• without (digital indicator hidden, setting: mA)	▶	1
• With visible digital indication		6
• With customer-specific digital indication (setting as specified, Order code "Y21" or required)		7
▶ Available ex stock		
Power supply units see "SITRANS I power supply units and isolation amplifiers".		
Factory-mounting of shut-off valves and valve manifolds see page 2/133.		
Included in delivery of the device:		
• Brief instructions (Leporello)		
• CD-ROM with detailed documentation		
• Sealing plug(s) or sealing screw(s) for the process flanges(s)		
1) For oxygen application, add Order code E10.		
2) Not suitable for connection of remote seal. Position of the top vent valve in the process flanges (see dimensional drawing).		
3) Only together with max. spans 250, 1600, 5000 and 30000 mbar (100.4, 240.9, 2008 inH ₂ O and 435 psi)		
4) When the manufacturer's certificate M (calibration certificate) has to be ordered for transmitters with diaphragm seals, it is recommended only to order this certificate exclusively with the diaphragm seals. The measuring accuracy of the total combination is certified here.		
5) When the acceptance test certificate 3.1 for transmitters with direct-connected diaphragm seals is ordered, this certificate must also be ordered with the corresponding seals.		
6) Not together with Electrical connection „Screwed gland Pg 13.5" and „Han7D plug".		
7) Without cable gland, with blanking plug		
8) With enclosed cable gland EEx ia and blanking plug		
9) Not together with type of protection "Explosion-proof" and and type of protection "Ex nA".		
10) Cannot be used together with the following types of protection: "Explosion-proof" and "Intrinsic safety and explosion-proof"		
F) Subject to export regulations AL: 91999, ECCN: N.		

SITRANS P measuring instruments for pressure

Transmitters for gage, absolute and differential pressure, flow and level

DS III series
for differential pressure and flow

2

Selection and Ordering data		Order No.
SITRANS P pressure transmitters for differential pressure and flow PN 32/160 (MWP 464/2320 psi)		
DS III PA series (PROFIBUS PA)		7 MF 4 4 3 4 -
DS III FF series (FOUNDATION Fieldbus)		7 MF 4 4 3 5 -
■ ■ ■ ■ ■ - ■ ■ ■ ■ ■		
Measuring cell filling	Measuring cell cleaning	
Silicone oil	Standard	1
Inert liquid ¹⁾	Grease-free	3
Nominal measuring range		
PN 32 (MWP 464 psi)		
20 mbar ²⁾	(8.03 inH ₂ O)	B
PN 160 (MWP 2320 psi)		
60 mbar	(24.09 inH ₂ O)	C
250 mbar	(100.4 inH ₂ O)	D
600 mbar	(240.9 inH ₂ O)	E
1600 mbar	(642.4 inH ₂ O)	F
5 bar	(2008 inH ₂ O)	G
30 bar	(435 psi)	H
Wetted parts materials		
(stainless steel process flanges)		
Seal diaphragm	Parts of measuring cell	
Stainless steel	Stainless steel	A
Hastelloy	Stainless steel	F) B
Hastelloy	Hastelloy	F) C
Tantalum ³⁾	Tantalum	E
Monel ²⁾	Monel	F) H
Gold ²⁾	Gold	L
Version as diaphragm seal ^{4) 5)}		Y
Process connection		
Female thread 1/4-18 NPT with flange connection		
• Sealing screw opposite process connection		
- Mounting thread M10 to DIN 19213		0
- Mounting thread 7/16-20 UNF to EN 61518		2
• Venting on side of process flanges ²⁾		
- Mounting thread M10 to DIN 19213		4
- Mounting thread 7/16-20 UNF to EN 61518		6
Non-wetted parts materials		
Process flange screws	Electronics housing	
Stainless steel	Die-cast aluminium	2
Stainless steel	Stainless steel precision casting	3
Version		
• Standard version		1
• International version, English label inscriptions, documentation in 5 languages on CD		2
Explosion protection		
• Without		A
• With CENELEC, Type of protection:		
- "Intrinsic safety (EEx ia)"		B
- "Explosion-proof (EEx d) ⁶⁾	F)	D
- "Intrinsic safety and explosion-proof enclosure (EEx ia + EEx d) ⁷⁾	F)	P
- "n (Zone 2)" (planned)		E
- "Intrinsic safety, explosion-proof enclosure and dust explosion protection (EEx ia + EEx d + Zone 1D/2D) ⁷⁾ (not for DS III FF)	F)	R
• With FM + CSA, Type of protection:		
- "Intrinsic safety and explosion-proof (is + xp) ⁶⁾	F)	NC

Selection and Ordering data		Order No.
SITRANS P pressure transmitters for differential pressure and flow PN 32/160 (MWP 464/2320 psi)		
DS III PA series (PROFIBUS PA)		7 MF 4 4 3 4 -
DS III FF series (FOUNDATION Fieldbus)		7 MF 4 4 3 5 -
■ ■ ■ ■ ■ - ■ ■ ■ ■ ■		
Electrical connection / cable entry		
• Screwed gland M20x1.5		B
• Screwed gland 1/2-14 NPT		C
• M12 connectors (metal) ⁸⁾		F
Display		
• Without (digital display hidden)		1
• With visible digital indication		6
• With customer-specific digital indication (setting as specified, Order code "Y21" or required)		7
Included in delivery of the device:		
• Brief instructions (Leporello)		
• CD-ROM with detailed documentation		
• Sealing plug(s) or sealing screw(s) for the process flanges(s)		
1) For oxygen application, add Order code E10.		
2) Not suitable for connection of remote seal. Position of the top vent valve in the process flanges (see dimensional drawing).		
3) Only together with max. spans 250, 1600, 5000 and 30000 mbar (100.4, 240.9, 2008 inH ₂ O and 435 psi).		
4) When the manufacturer's certificate M (calibration certificate) has to be ordered for transmitters with diaphragm seals, it is recommended only to order this certificate exclusively with the diaphragm seals. The measuring accuracy of the <u>total</u> combination is certified here.		
5) When the acceptance test certificate 3.1 for transmitters with direct-connected diaphragm seals is ordered, this certificate must also be ordered with the corresponding seals.		
6) Without cable gland, with blanking plug.		
7) With enclosed cable gland EEx ia and blanking plug.		
8) Cannot be used together with the following types of protection: "Explosion-proof" and "Intrinsic safety and explosion-proof".		
F) Subject to export regulations AL: 91999, ECCN: N.		

SITRANS P measuring instruments for pressure

Transmitters for gage, absolute and differential pressure, flow and level

DS III series for differential pressure and flow

2

Selection and Ordering data	Order code		
<i>Further designs</i> Add "-Z" to Order No. and specify Order code.	HART	PA	FF
Pressure transmitter with mounting bracket made of:			
• Steel	A01	✓	✓
• Stainless steel	A02	✓	✓
O-rings for process flanges (instead of FPM (Viton))			
• PTFE (Teflon)	A20	✓	✓
• FEP (with silicone core, approved for food)	A21	✓	✓
• FFFM (Kalrez, compound 4079)	A22	✓	✓
• NBR (Buna N)	A23	✓	✓
Plug			
• Han 7D (metal, gray)	A30	✓	
• Han 8U (instead of Han 7D)	A31	✓	
	A40	✓	✓
Sealing screws ¼-18 NPT, with valve in mat. of process flanges			
Cable sockets for M12 connectors (metal)	A50	✓	✓
Rating plate inscription (instead of German)			
• English	B11	✓	✓
• French	B12	✓	✓
• Spanish	B13	✓	✓
• Italian	B14	✓	✓
English rating plate (calibration certificate) Pressure units in inH ₂ O or psi	B21	✓	✓
Manufacturer's test certificate M¹⁾ To DIN 55350, Part 18 and to ISO 8402	C11	✓	✓
Acceptance test certificate²⁾ To EN 10 204-3.1	C12	✓	✓
Factory certificate To EN 10 204-2.2	C14	✓	✓
"Functional Safety (SIL)" certificate	C20	✓	
"PROFIsafe" certificate and protocol	C21		✓
Setting of upper limit of output signal to 22.0 mA	D05	✓	
Manufacturer's declaration acc. to NACE (only together with seal diaphragm made of Hastelloy and stainless steel)	D07	✓	✓
Type of protection IP68 (not together with 7D/ Han 8U plug, cable gland Pg 13.5)	D12	✓	✓
Digital indicator alongside the input keys (only together with the devices 7MF4433-...-2-.A.6 or -.A.7-Z, Y21 or Y22 + Y01)	D27	✓	✓
Process flange screws made of Monel (max. nominal pressure PN20)	D34	✓	✓
Supplied with oval flange set (2 items), PTFE packings and stainless steel screws in thread of process flanges	D37 ^{F)}	✓	✓
Use in or on zone 1D/2D (only together with type of protection "Intrinsic safety (EEx ia)")	E01	✓	✓
Use on zone 0 (only together with type of protection "Intrinsic safety (EEx ia)")	E02	✓	✓
TÜV approval to AD/TRD (only together with type of protection "Intrinsic safety (EEx ia)")	E06	✓	
Overfilling safety device for flammable and non-flammable liquids (max. PN 32 (MVWP 464 psi), basic device with type of protection "Intrinsic safety (EEx ia)", to WHG and VbF, not together with measuring cell filling "inert liquid")	E08	✓	✓

Selection and Ordering data	Order code		
<i>Further designs</i> Add "-Z" to Order No. and specify Order code.	HART	PA	FF
Oxygen application (max. 160 bar (2320 psi) with oxygen measurement and inert liquid)	E10	✓	✓
Explosion-proof "Intrinsic safety" to INMETRO (Brazil) (only for transmitter 7MF4...-.....-B..)	E25	✓	✓
Explosion-proof "Intrinsic safety" to NEPSI (China) (only for transmitter 7MF4...-.....-B..)	E55	✓	✓
Explosion protection "Explosion-proof" to NEPSI (China) (only for transmitter 7MF4...-.....-D..)	E56	✓	✓
Explosion-proof "Zone 2" to NEPSI (China) (only for transmitter 7MF4...-.....-E..)	E57	✓	✓
Interchanging of process connection side	H01	✓	✓
Vent on side for gas measurements	H02	✓	✓
Stainless steel process flanges for vertical differential pressure lines (not together with K01, K02 and K04 ³⁾)	H03	✓	✓
Process flange			
• Hastelloy	K01 ^{F)}	✓	✓
• Monel	K02 ^{F)}	✓	✓
• Stainless steel with PVDF insert max. PN 10 (MWP 145 psi), max. temperature of medium 90 °C (194 °F)	K04	✓	✓
For ½-14 NPT inner process connection on the side in the middle of the process flange, vent valve not possible			

✓ = available

1) When the manufacture's certificate M (calibration certificate) has to be ordered for transmitters with diaphragm seals, it is recommended only to order this certificate exclusively with the diaphragm seals. The measuring accuracy of the total combination is certified here.

2) When the acceptance test certificate 3.1 for transmitters with direct-connected diaphragm seals is ordered, this certificate must also be ordered with the corresponding seals.

3) Not suitable for connection of remote seal

F) Subject to export regulations AL: 9I999, ECCN: N.

SITRANS P measuring instruments for pressure

Transmitters for gage, absolute and differential pressure, flow and level

DS III series
for differential pressure and flow

2

Selection and Ordering data	Order code		
Additional data	HART	PA	FF
Add "-Z" to Order No. and specify Order code.			
Measuring range to be set Specify in plain text:			
• With linear characteristic (max. 5 digits): Y01: ... up to ... mbar, bar, kPa, MPa, psi	Y01	✓	
• With square-rooted characteristic (max. 5 digits): Y02: ... up to ... mbar, bar, kPa, MPa, psi	Y02	✓	
Measuring point number (TAG No.) Max. 16 char., specify in plain text: Y15:	Y15	✓	✓
Measuring point text Max. 27 char., specify in plain text: Y16:	Y16	✓	✓
Entry of HART address (TAG) Max. 8 char., specify in plain text: Y17:	Y17	✓	
Setting of pressure indicator in pressure units Specify in plain text (standard setting: mA): Y21: mbar, bar, kPa, MPa, psi, ... Note: The following pressure units can be selected: bar, mbar, mm H ₂ O ¹⁾ , inH ₂ O ¹⁾ , ftH ₂ O ¹⁾ , mmHG, inHG, psi, Pa, kPa, MPa, g/cm ² , kg/cm ² , Torr, ATM oder % *) ref. temperature 20 °C	Y21	✓	✓
Setting of pressure indicator in non-pressure units Specify in plain text: Y22: up to l/min, m ³ /h, m, USgpm, ... (specification of measuring range in pressure units "Y01" or "Y02" is essential, unit with max. 5 characters)	Y22 ¹⁾ + Y01 or Y02	✓	
Preset bus address Specify in plain text: Y25:	Y25		✓

Only "Y01", "Y21", "Y22", "Y25" and "D05" can be factory preset

✓ = available

¹⁾ Not together with over-filling safety device for flammable and non-flammable liquids (Order code "E08")

SITRANS P measuring instruments for pressure

Transmitters for gage, absolute and differential pressure, flow and level

DS III series for differential pressure and flow

2

Selection and Ordering data		Order No.
SITRANS P pressure transmitters for differential pressure and flow, Series DS III HART PN 420 (MWP 6092 psi)		7 MF 4 5 3 3 -
Measuring cell filling	Measuring cell cleaning	
Silicone oil	Standard	1
Span		
2.5 ... 250 mbar	(1.004 ... 100.4 inH ₂ O)	D
6 ... 600 mbar	(2.409 ... 240.9 inH ₂ O)	E
16 ... 1600 mbar	(6.424 ... 642.4 inH ₂ O)	F
50 ... 5000 mbar	(20.08 ... 2008 inH ₂ O)	G
0.3 ... 30 bar	(4.35 ... 435 psi)	H
Wetted parts materials (stainless steel process flanges)		
Seal diaphragm	Parts of measuring cell	
Stainless steel	Stainless steel	A
Hastelloy	Stainless steel	B
Gold ¹⁾	Gold	L
Process connection		
Female thread 1/4-18 NPT with flange connection		
• Sealing screw opposite process connection		
- Mounting thread M12 to DIN 19213		1
- Mounting thread 7/16-20 UNF to EN 61518		3
• Venting on side of process flanges. Position of the top vent valve in the process flanges (see dimensional drawing).		
- Mounting thread M12 to DIN 19213		5
- Mounting thread 7/16-20 UNF to EN 61518		7
Non-wetted parts materials		
Process flange screws	Electronics housing	
Stainless steel	Die-cast aluminium	2
Stainless steel	Stainless steel precision casting ²⁾	3
Version		
• Standard version		1
• International version, English label inscriptions, documentation in 5 languages on CD		2
Explosion protection		
• Without		A
• With ATEX, Type of protection:		
- "Intrinsic safety (EEx ia)"		B
- "Explosion-proof (EEx d) ³⁾	F)	D
- "Intrinsic safety and explosion-proof enclosure (EEx ia + EEx d) ⁴⁾	F)	P
- "Ex nA/nL (zone 2)"		E
- "Intrinsic safety, explosion-proof enclosure and dust explosion protection (EEx ia + EEx d + Zone 1D/2D) ⁴⁾	F)	R
• With FM + CSA, Type of protection:		
- "Intrinsic safety and explosion-proof (is + xp) ³⁾ , max PN 360	F)	NC
Electrical connection / cable entry		
• Screwed gland Pg 13.5 ⁵⁾		A
• Screwed gland M20x1.5		B
• Screwed gland 1/2-14 NPT		C
• Han 7D plug (plastic housing) incl. mating connector ⁵⁾		D
• M12 connectors (metal) ⁶⁾		F

Selection and Ordering data		Order No.
SITRANS P pressure transmitters for differential pressure and flow, Series DS III HART PN 420 (MWP 6092 psi)		7 MF 4 5 3 3 -
Display		
• without (digital indicator hidden, setting: mA)		1
• With visible digital indication		6
• With customer-specific digital indication (setting as specified, Order code "Y21" or required)		7

Power supply units see "SITRANS I power supply units and isolation amplifiers".

Scope of delivery: Pressure transmitter as ordered (Instruction Manual is extra ordering item)

- 1) Not together with max. span 600 mbar (240.9 inH₂O)
- 2) Not together with Electrical connection „Screwed gland Pg 13.5“ and „Han7D plug“.
- 3) Without cable gland, with blanking plug
- 4) With enclosed cable gland EEx ia and blanking plug
- 5) Not together with type of protection "Explosion-proof" and and type of protection "Ex nA".
- 6) Cannot be used together with the following types of protection: "Explosion-proof" and "Intrinsic safety and explosion-proof".

F) Subject to export regulations AL: 91999, ECCN: N.

SITRANS P measuring instruments for pressure

Transmitters for gage, absolute and differential pressure, flow and level

DS III series
for differential pressure and flow

2

Selection and Ordering data		Order No.
SITRANS P pressure transmitters for differential pressure and flow, Series DS III HART PN 420 (MWP 6092 psi)		
DS III PA (PROFIBUS PA) series		7MF4534 -
DS III FF series (FOUNDATION Fieldbus)		7MF4535 -
		1 ■ ■ ■ ■ - ■ ■ ■ ■
Nominal measuring range		
250 mbar	(100.4 inH ₂ O)	D
600 mbar	(240.9 inH ₂ O)	E
1600 mbar	(642.4 inH ₂ O)	F
5 bar	(2008 inH ₂ O)	G
30 bar	(435 psi)	H
Wetted parts materials		
(stainless steel process flanges)		
Seal diaphragm	Parts of measuring cell	
Stainless steel	Stainless steel	A
Hastelloy	Stainless steel	B
Gold ¹⁾	Gold	L
Process connection		
Female thread 1/4-18 NPT with flange connection		
• Sealing screw opposite process connection		
- Mounting thread M12 to DIN 19213		1
- Mounting thread 7/16-20 UNF to EN 61518		3
• Venting on side of process flanges. Position of the top vent valve in the process flanges (see dimensional drawing).		
- Mounting thread M12 to DIN 19213		5
- Mounting thread 7/16-20 UNF to EN 61518		7
Non-wetted parts materials		
Process flange screws	Electronics housing	
Stainless steel	Die-cast aluminium	2
Stainless steel	Stainless steel precision casting	3
Version		
• Standard version		1
• International version, English label inscriptions, documentation in 5 languages on CD		2
Explosion protection		
• Without		A
• With CENELEC, Type of protection:		
- "Intrinsic safety (EEx ia)"		B
- "Explosion-proof (EEx d) ²⁾	F)	D
- "Intrinsic safety and explosion-proof enclosure (EEx ia + EEx d) ³⁾	F)	P
- "Ex nA/nL (zone 2)"		E
- "Intrinsic safety, explosion-proof enclosure and dust explosion protection (EEx ia + EEx d + Zone 1D/2D) ³⁾ (not for DS III FF)	F)	R
• With FM + CSA, Type of protection:		
- "Intrinsic safety and explosion-proof (is + xp) ²⁾ , max PN 360	F)	NC
Electrical connection / cable entry		
• Screwed gland M20x1.5		B
• Screwed gland 1/2-14 NPT		C
• Plug M12 incl. mating connector ⁴⁾		F
Display		
• Without (digital display hidden)		1
• With visible digital indicator		6
• With customer-specific digital indicator (setting as specified, Order code "Y21" or required)		7

- 1) Not together with max. span 600 mbar (240.9 inH₂O)
 - 2) Without cable gland, with blanking plug.
 - 3) With enclosed cable gland EEx ia and blanking plug.
 - 4) Not together with types of protection "Explosion-proof" and "Intrinsic safety and explosion-proof"
- F) Subject to export regulations AL: 9I999, ECCN: N.

Factory-mounting of shut-off valves and valve manifolds see page 2/133.

Included in delivery of the device:

- Brief instructions (Leporello)
- CD-ROM with detailed documentation
- Sealing plug(s) or sealing screw(s) for the process flanges(s)

SITRANS P measuring instruments for pressure

Transmitters for gage, absolute and differential pressure, flow and level

DS III series for differential pressure and flow

2

Selection and Ordering data	Order code		
<i>Further designs</i>	HART	PA	FF
Add "-Z" to Order No. and specify Order code.			
Pressure transmitter with mounting bracket made of:			
• Steel	A01	✓	✓
• Stainless steel	A02	✓	✓
O-rings for process flanges (instead of FPM (Viton))			
• PTFE (Teflon)	A20	✓	✓
• FEP (with silicone core, approved for food)	A21	✓	✓
• FFPM (Kalrez, compound 4079)	A22	✓	✓
• NBR (Buna N)	A23	✓	✓
Plug			
• Han 7D (metal, gray)	A30	✓	
• Han 8U (instead of Han 7D)	A31	✓	
Sealing screws	A40	✓	✓
¼-18 NPT, with valve in material of process flanges			
Cable sockets for M12 connectors (metal)	A50	✓	✓
Rating plate inscription (instead of German)			
• English	B11	✓	✓
• French	B12	✓	✓
• Spanish	B13	✓	✓
• Italian	B14	✓	✓
English rating plate Pressure units in inH ₂ O or psi	B21	✓	✓
Manufacturer's test certificate M (calibration certificate) To DIN 55350, Part 18 and to ISO 8402	C11	✓	✓
Acceptance test certificate To EN 10204-3.1	C12	✓	✓
Factory certificate To EN 10204-2.2	C14	✓	✓
"Functional Safety (SIL)" certificate	C20	✓	
"PROFIsafe" certificate and protocol	C21	✓	
Setting of upper limit of output signal to 22.0 mA	D05	✓	
Manufacturer's declaration acc. to NACE (only together with seal diaphragm made of Hastelloy and stainless steel)	D07	✓	✓
Type of protection IP68 (not together with Han 7D / Han 8U plug, Pg 13.5 screwed gland)	D12	✓	✓
Digital indicator alongside the input keys (only together with the devices 7MF4533-...-2-.A.6 or -.A.7-Z, Y21 or Y22 + Y01)	D27	✓	✓
Use in or on zone 1D/2D (only together with type of protection "Intrinsic safety (EEx ia)")	E01	✓	✓
Use on zone 0 (only together with type of protection "Intrinsic safety (EEx ia)")	E02	✓	✓
Explosion-proof "Intrinsic safety" to INMETRO (Brazil) (only for transmitter 7MF4...-.....-B..)	E25	✓	✓
Explosion-proof "Intrinsic safety" to NEPSI (China) (only for transmitter 7MF4...-.....-B..)	E55	✓	✓

Selection and Ordering data	Order code		
<i>Further designs</i>	HART	PA	FF
Add "-Z" to Order No. and specify Order code.			
Explosion protection "Explosion-proof" to NEPSI (China) (only for transmitter 7MF4...-.....-D..)	E56	✓	✓
Explosion-proof "Zone 2" to NEPSI (China) (only for transmitter 7MF4...-.....-E..)	E57	✓	✓
Interchanging of process connection side	H01	✓	✓
Stainless steel process flanges for vertical differential pressure lines	H03	✓	✓
Additional data			
Add "-Z" to Order No. and specify Order code.			
Measuring range to be set Specify in plain text:			
• With linear characteristic (max. 5 digits): Y01: ... up to ... mbar, bar, kPa, MPa, psi	Y01	✓	✓
• With square-rooted characteristic (max. 5 digits): Y02: ... up to ... mbar, bar, kPa, MPa, psi	Y02	✓	✓
Measuring point number (TAG No.) Max. 16 characters, specify in plain text: Y15:	Y15	✓	✓
Measuring point text Max. 27 characters, specify in plain text: Y16:	Y16	✓	✓
Entry of HART address (TAG) Max. 8 characters, specify in plain text: Y17:	Y17	✓	
Setting of pressure indication in pressure units Specify in plain text (standard setting: mA): Y21: mbar, bar, kPa, MPa, psi, ... Note: The following pressure units can be selected: bar, mbar, mm H ₂ O ¹ , inH ₂ O ¹ , ftH ₂ O ¹ , mmHG, inHG, psi, Pa, kPa, MPa, g/cm ² , kg/cm ² , Torr, ATM or %) ref. temperature 20 °C	Y21	✓	✓
Setting of pressure indication in non-pressure units Specify in plain text: Y22: up to l/min, m ³ /h, m, USgpm, ... (specification of measuring range in pressure units "Y01" or "Y02" is essential, unit with max. 5 characters)	Y22 + Y01 or Y02	✓	
Preset bus address Specify in plain text: Y25:	Y25		✓

Only "Y01", "Y21", "Y22", "Y25" and "D05" can be factory preset

✓ = available

SITRANS P measuring instruments for pressure

Transmitters for gage, absolute and differential pressure, flow and level

DS III series
for differential pressure and flow

2

Dimensional drawings

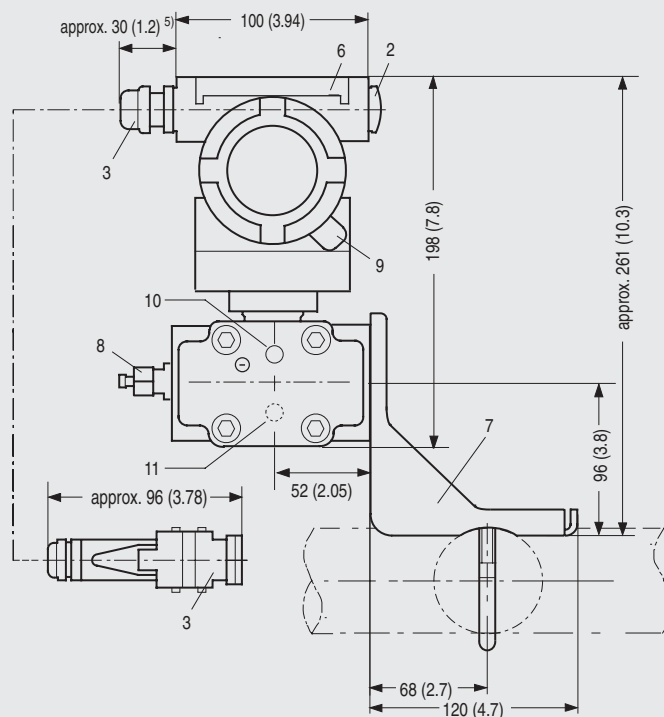
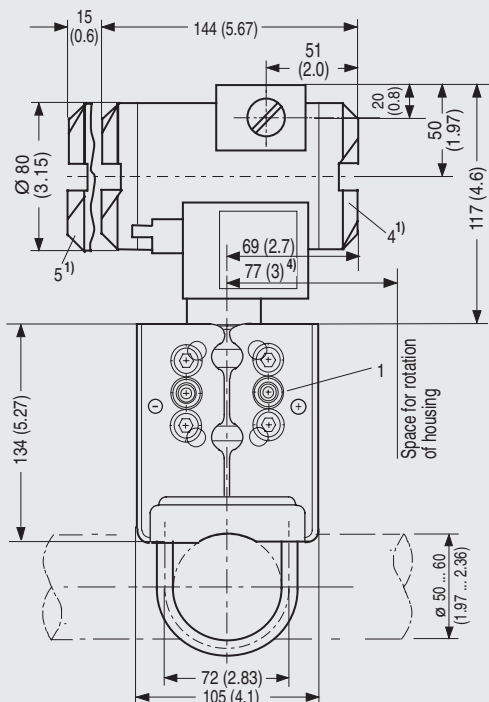

- 1 Process connection: 1/4-18 NPT (EN 61518)
- 2 Blanking plug
- 3 Electrical connection:
 - screwed gland Pg 13,5 (adapter)^{2) 3)},
 - screwed gland M20x1,5³⁾,
 - screwed gland 1/2-14 NPT or
 - Han 7D/ Han 8U plug^{2) 3)}
- 4 Terminal side
- 5 Electronics side, digital display (longer overall length for cover with window)
- 6 Protective cover over keys
- 7 Mounting bracket (option)
- 8 Sealing screw with valve (option)
- 9 Screw cover - safety bracket (only for type of protection "Explosion-proof enclosure", not shown in the drawing)
- 10 Lateral venting for liquid measurement (Standard)
- 11 Lateral venting for gas measurement (suffix H02)

- 1) Allow approx. 20 mm (0.79 inch) thread length to permit unscrewing
- 2) Not with type of protection "explosion-proof enclosure"
- 3) Not with type of protection "FM + CSA [is + xpl]"
- 4) 92 mm (3.62 inch) for minimum distance to permit rotation with indicator
- 5) 45 mm (1.8 inch) for Pg 13,5 with adapter

SITRANS P pressure transmitters, DS III HART series for differential pressure and flow, dimensions in mm (inch)

SITRANS P measuring instruments for pressure

Transmitters for gage, absolute and differential pressure, flow and level

DS III series
for differential pressure and flow

2

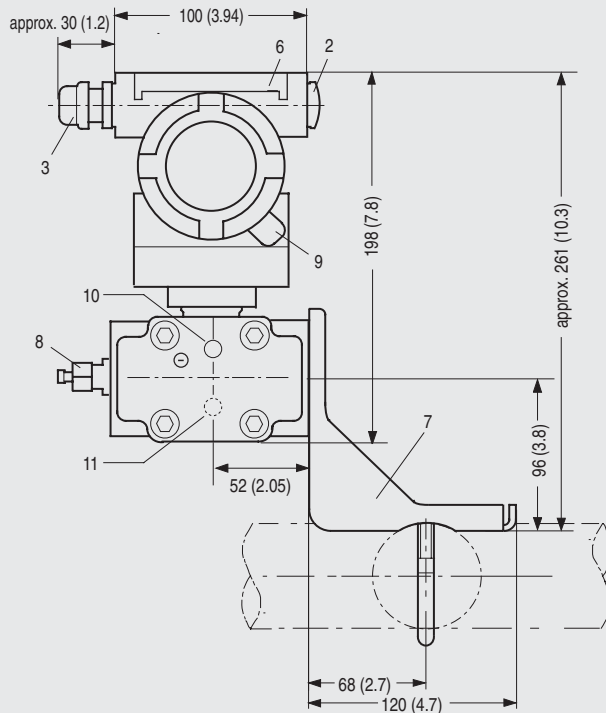
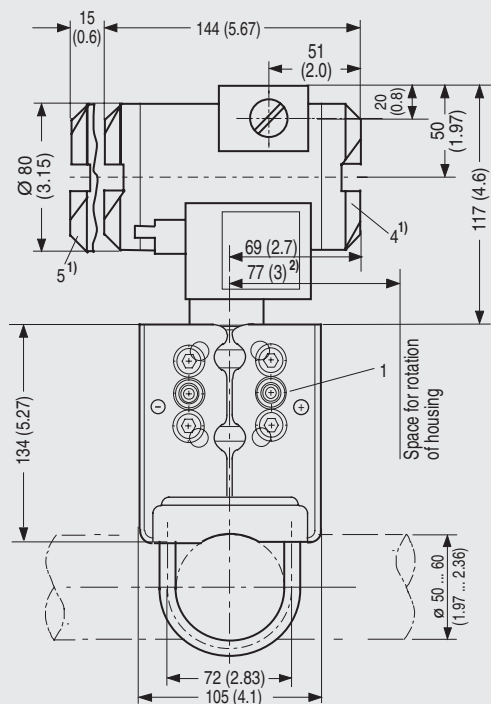

- 1 Process connection: 1/4-18 NPT (EN 61518)
- 2 Blanking plug
- 3 Electrical connection:
 - screwed gland M20x1,5⁴⁾,
 - screwed gland 1/2-14 NPT or
 - PROFIBUS plug M12^{3) 4)}
- 4 Terminal side
- 5 Electronic side, digital display (longer overall length for cover with window)
- 6 Protective cover over keys
- 7 Mounting bracket (option)
- 8 Sealing screw with valve (option)
- 9 Screw cover – safety bracket (only for explosion-proof enclosure, not shown in the drawing)
- 10 Lateral venting for liquid measurement (Standard)
- 11 Lateral venting for gas measurement (suffix H02)

- 1) Allow approx. 20 mm (0.79 inch) thread length in addition
- 2) 92 mm (3.62 inch) for minimum distance to permit rotation with indicator
- 3) Not with type of protection "explosion-proof enclosure"
- 4) Not with type of protection "FM + CSA"

SITRANS P pressure transmitters, DS III PA and FF series for differential pressure and flow, dimensions in mm (inch)

SITRANS P measuring instruments for pressure

Transmitters for gage, absolute and differential pressure, flow and level

DS III series
for differential pressure and flow

2

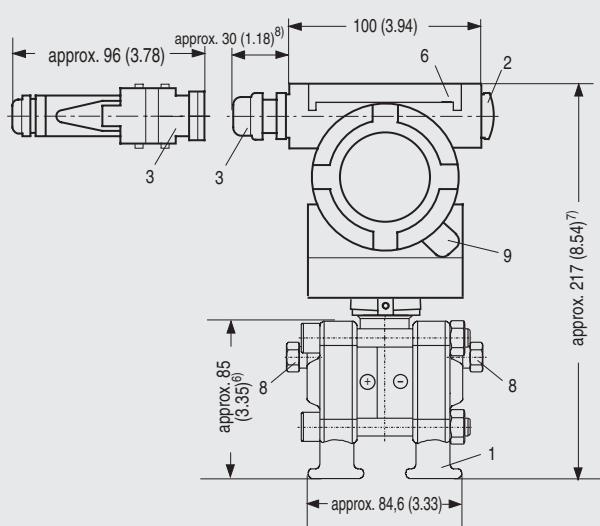
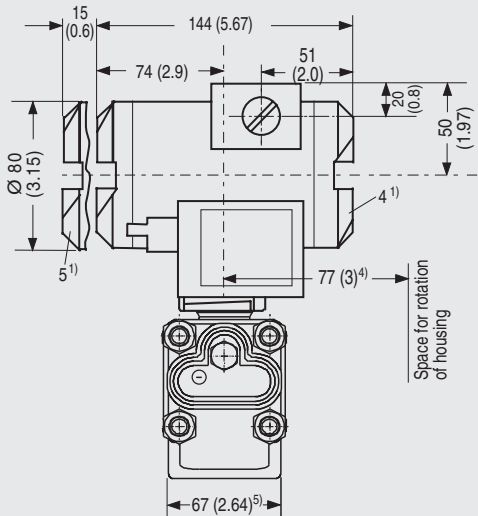

- 1 Process connection: 1/4-18 NPT (EN 61518)
- 2 Blanking plug
- 3 Electrical connection:
 - screwed gland Pg 13.5 (adapter) 2) 3),
 - screwed gland M20x1,5 3),
 - screwed gland 1/2-14 NPT or
 - Han 7D/ Han 8U plug 2) 3)
- 4 Terminal side
- 5 Electronics side, digital display (longer overall length for cover with window)
- 6 Protective cover over keys
- 7 Mounting bracket (option)
- 8 Sealing screw with valve (option)
- 9 Screw cover - safety bracket (only for type of protection "Explosion-proof enclosure", not shown in the drawing)

- 1) Allow approx. 20 mm (0.79 inch) thread length to permit unscrewing
- 2) Not with type of protection "explosion-proof enclosure"
- 3) Not with type of protection "FM + CSA [is + xp]"
- 4) 92 mm (3.6 inch) for minimum distance to permit rotation with indicator
- 5) 74 mm (2.9 inch) for PN ≥ 420 (MWP ≥ 6092 psi)
- 6) 91 mm (3.6 inch) for PN ≥ 420 (MWP ≥ 6092 psi)
- 7) 219 mm (8.62 inch) for PN ≥ 420 (MWP ≥ 6092 psi)
- 8) 45 mm (1.8 inch) for Pg 13,5 with adapter

SITRANS P pressure transmitters, DS III HART series for differential pressure and flow, with process covers for vertical differential pressure lines, dimensions in mm (inch)

SITRANS P measuring instruments for pressure

Transmitters for gage, absolute and differential pressure, flow and level

DS III series for differential pressure and flow

2

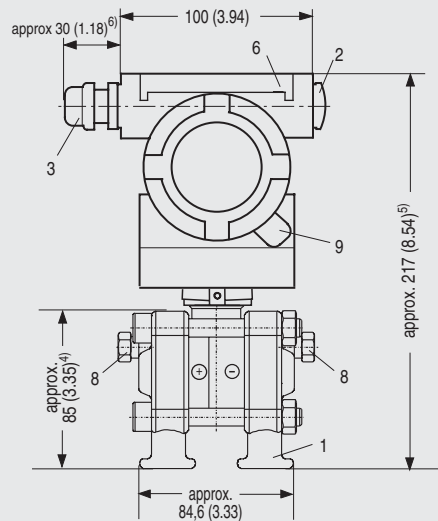
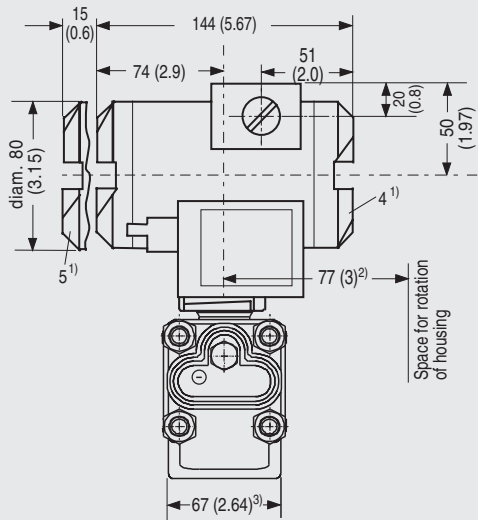

- 1 Process connection 1/4-18 NPT (EN 61 518)
 - 2 Blanking plug
 - 3 Electrical connection:
screwed gland M20x1.5,
screwed gland 1/2-14 NPT or
PROFIBUS plug M12
 - 4 Terminal side
 - 5 Electronics side, digital display (longer overall length for cover with window)
 - 6 Protective cover over keys
 - 7 Mounting bracket (option)
 - 8 Sealing screw with valve (option)
 - 9 Screw cover safety bracket (only for explosion-proof enclosure, not shown in the drawing)
- 1) Allow approx. 20 mm (0.79 inch) thread length in addition
 - 2) 92 mm (3.6 inch) for minimum distance to permit rotation without indicator
 - 3) 74 mm (2.9 inch) for PN ≥ 420 (MWP ≥ 6092 psi)
 - 4) 91 mm (3.6 inch) for PN ≥ 420 (MWP ≥ 6092 psi)
 - 5) 219 mm (8.62 inch) for PN ≥ 420 (MWP ≥ 6092 psi)
 - 6) Approx. 45 mm (1.77 inch) for Pg 13.5 with adapter

SITRANS P pressure transmitters, DS III PA and FF series for differential pressure and flow, with process covers for vertical differential pressure lines, dimensions in mm (inch)

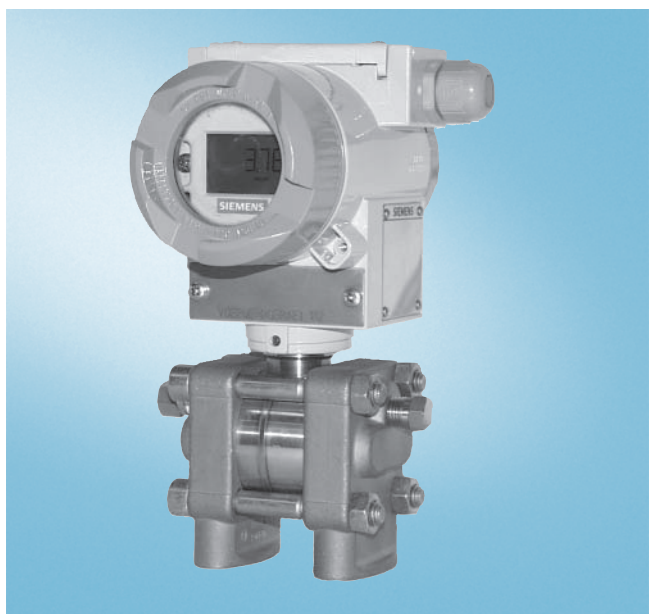

SITRANS P pressure transmitters, DS III series for differential pressure and flow, with process covers for vertical differential pressure lines

SITRANS P measuring instruments for pressure

Transmitters for gage, absolute and differential pressure, flow and level

DS III series
for differential pressure and flow

2

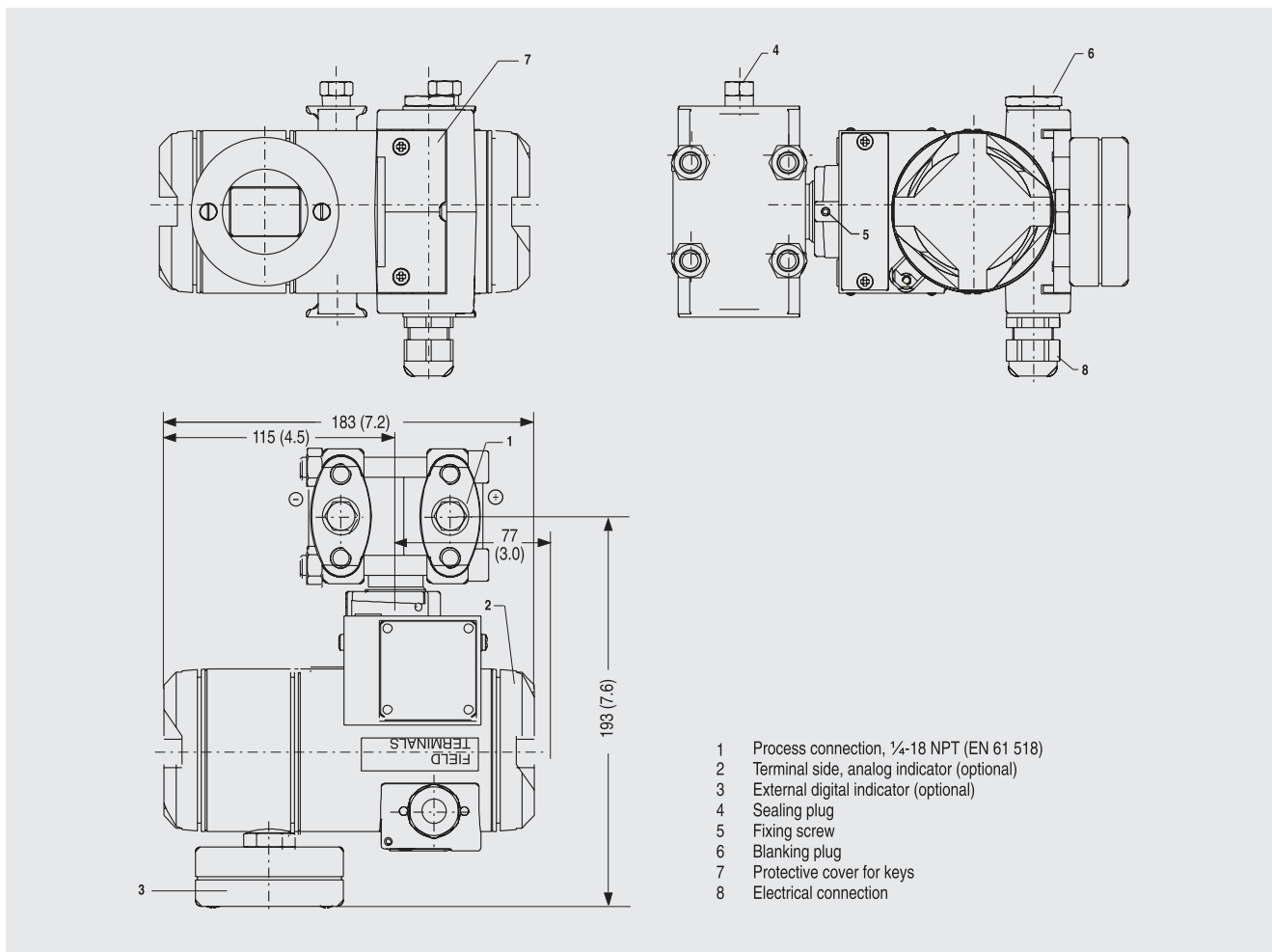

SITRANS P pressure transmitters, DS III FF series for differential pressure and flow, with digital indicator beside control keys, dimensions in mm (inch)



SITRANS P pressure transmitters, DS III series for differential pressure and flow, with digital indicator beside control keys

SITRANS P measuring instruments for pressure

Transmitters for gage, absolute and differential pressure, flow and level

DS III series for level

Technical specifications

SITRANS P, DS III series for level

	HART	PROFIBUS PA or FOUNDATION Fieldbus
Input		
Measured variable	Level	
Spans (infinitely adjustable) or nominal measuring range and max. permissible working pressure	Span 25 ... 250 mbar g (0.36 ... 3.63 psi g) 25 ... 600 mbar g (0.36 ... 8.7 psi g) 53 ... 1600 mbar g (0.77 ... 23.2 psi g) 160 ... 5000 mbar g (2.32 ... 72.5 psi g)	Maximum working pressure Nominal measuring range 250 mbar g (3.63 psi g) 600 mbar g (8.7 psi g) 1600 mbar g (23.2 psi g) 5000 mbar g (72.5 psi g)
Lower measuring limit		Maximum working pressure
• Measuring cell with silicone oil filling	-100% of max. span or 30 mbar (0.435 psi a), depending on mounting flange	See "Mounting flange"
Upper measuring limit	100% of max. span	See "Mounting flange"
Output		
Output signal	4 ... 20 mA	Digital PROFIBUS PA or FOUNDATION Fieldbus signal
• Lower limit (infinitely adjustable)	3.55 mA, factory preset to 3.84 mA	-
• Upper limit (infinitely adjustable)	23 mA, factory preset to 20.5 mA or optionally set to 22.0 mA	-
Load		
• Without HART communication	$R_B \leq (U_H - 10.5 \text{ V})/0.023 \text{ A in } \Omega$ U_H : Power supply in V	-
• With HART communication	$R_B = 230 \dots 500 \Omega$ (SIMATIC PDM) or $R_B = 230 \dots 1100 \Omega$ (HART Communicator)	-
Physical bus	-	IEC 61158-2
With polarity reversal protection	-	Yes
Accuracy	To EN 60770-1	
Reference conditions	Increasing characteristic, start-of-scale value 0 bar, stainless steel seal diaphragm, silicone oil filling, room temperature 25 °C (77 °F) r: Span ratio (r = max. span / set span)	
Error in measurement and fixed-point setting (including hysteresis and repeatability)		
• Linear characteristic		≤ 0,075%
- r ≤ 10	≤ 0,15%	
- 10 < r ≤ 30	≤ 0,3%	
- 30 < r ≤ 100	≤ (0.0075 · r + 0.075)%	
Long-term drift (temperature change ±30 °C (±54 °F))	≤ (0.25 · r)% every 5 years static pressure max. 70 bar g (1015 psi g)	≤ (0.25% every 5 years static pressure max. 70 bar g (1015 psi g)
Influence of ambient temperature		
• at -10 ... +60 °C (14 ... 140 °F)		
- 250-mbar (3.63 psi) measuring cell	≤ (0.5 · r + 0.2)% (0.4 instead of 0.2 with 10 < r ≤ 30)	≤ 0,7%
- 600-mbar (8.7 psi) measuring cell	≤ (0.3 · r + 0.2)% (0.4 instead of 0.2 with 10 < r ≤ 30)	≤ 0,5%
- 1600 and 5000 mbar (23.2 and 72.5 psi) measuring cells	≤ (0.25 · r + 0.2)% (0.4 instead of 0.2 with 10 < r ≤ 30)	≤ 0,45%
• at -40 ... -10 °C and +60 ... +85 °C (-40 ... +14 °F and 140 ... 185 °F)		
- 250 mbar (3.63 psi) measuring cell	≤ (0.25 · r + 0.15)%/10 K double values with 10 < r ≤ 30	≤ 0.4%/10 K
- 600 mbar (8.7 psi) measuring cell	≤ (0.15 · r + 0.15)%/10 K double values with 10 < r ≤ 30	≤ 0.3%/10 K
- 1600 and 5000 mbar (23.2 and 72.5 psi) measuring cells	≤ (0.12 · r + 0.15)%/10 K double values with 10 < r ≤ 30	≤ 0.27%/10 K

SITRANS P measuring instruments for pressure

Transmitters for gage, absolute and differential pressure, flow and level

DS III series
for level

2

SITRANS P, DS III series for level

	HART	PROFIBUS PA or FOUNDATION Fieldbus
<p>Influence of static pressure</p> <ul style="list-style-type: none"> on the zero point <ul style="list-style-type: none"> - 250 mbar (3.63 psi) measuring cell - 600 mbar (8.7 psi) measuring cell - 1600 and 5000 mbar (23.2 and 72.5 psi) measuring cells on the span <p>Measured Value Resolution</p>	<p>≤ (0.3 · r)% per nominal pressure</p> <p>≤ (0.15 · r)% per nominal pressure</p> <p>≤ (0.1 · r)% per nominal pressure</p> <p>≤ (0.1 · r)% per nominal pressure</p> <p>-</p>	<p>≤ 0.3% per nominal pressure</p> <p>≤ 0.15% per nominal pressure</p> <p>≤ 0.1% per nominal pressure</p> <p>≤ 0.1% per nominal pressure</p> <p>3 · 10⁻⁵ of nominal measuring range</p>
<p>Rated operating conditions</p> <p>Degree of protection (to EN 60529)</p> <p>Process temperature</p> <ul style="list-style-type: none"> Measuring cell with silicone oil filling <ul style="list-style-type: none"> - High-pressure side - Low-pressure side <p>Ambient conditions</p> <ul style="list-style-type: none"> Ambient temperature <ul style="list-style-type: none"> - Digital indicators Storage temperature Climatic class <ul style="list-style-type: none"> - Condensation Electromagnetic compatibility <ul style="list-style-type: none"> - Emitted interference and interference immunity 	<p>IP65</p> <p>Note: Always take into account assignment of max. permissible working temperature to max. permissible working pressure of the respective flange connection!</p> <p>-40 ... +100 °C (-40 ... +212 °F)</p> <p>p_{abs} ≥ 1bar: -40 ... +175 °C (-40 ... +347 °F)</p> <p>p_{abs} ≥ 1bar: -40 ... +80 °C (-40 ... +176 °F)</p> <p>-40 ... +100 °C (-40 ... +212 °F)</p> <p>-20 ... +60 °C (-4 ... +140 °F) in conjunction with dust explosion protection</p> <p>-30 ... +85 °C (-22 ... +185 °F)</p> <p>-50 ... +85 °C (-58 ... +185 °F)</p> <p>Permissible</p> <p>To EN 61326 and NAMUR NE 21</p>	
<p>Design</p> <p>Weight (without options)</p> <ul style="list-style-type: none"> To EN (pressure transmitter with mounting flange, without tube) To ASME (pressure transmitter with mounting flange, without tube) <p>Wetted parts materials</p> <p>Housing material</p> <p>High-pressure side</p> <ul style="list-style-type: none"> Seal diaphragm of mounting flange <p>Measuring cell filling</p> <p>Process connection</p> <ul style="list-style-type: none"> High-pressure side Low-pressure side 	<p>≈ 11 ... 13 kg (≈ 24.2 ... 28.7 lb)</p> <p>≈ 11 ... 18 kg (≈ 24.2 ... 39.7 lb)</p> <p>Poor in copper die-cast aluminium, GD-AISI12 or stainless steel precision casting, mat. No. 1.4408</p> <p>Stainless steel, mat. No. 1.4404/316L, Monel, mat. No. 2.4360, Hastelloy B2, mat. No. 2.4617, Hastelloy C276, mat. No. 2.4819, Hastelloy C4, mat. No. 2.4610, tantalum, PTFE, ECTFE</p> <p>Silicone oil</p> <p>Flange to EN and ASME</p> <p>Female thread 1/4-18 NPT and flange connection with mounting thread M10 to DIN 19213 or 7/16-20 UNF to EN 61518</p>	
<p>Power supply U_H</p> <p>Terminal voltage on transmitter</p> <p>Separate 24 V power supply necessary</p> <p>Bus voltage</p> <ul style="list-style-type: none"> Not Ex With intrinsically-safe operation <p>Current consumption</p> <ul style="list-style-type: none"> Basic current (max.) Startup current ≤ basic current Max. current in event of fault <p>Fault disconnection electronics (FDE) available</p>	<p>10.5 ... 45 V DC</p> <p>10.5 ... 30 V DC in intrinsically-safe mode</p> <p>-</p> <p>-</p> <p>-</p> <p>-</p> <p>-</p> <p>-</p> <p>-</p> <p>-</p> <p>-</p>	<p>Supplied through bus</p> <p>-</p> <p>No</p> <p>9 ...32 V</p> <p>9 ...24 V</p> <p>12.5 mA</p> <p>Yes</p> <p>15.5 mA</p> <p>Yes</p>

SITRANS P measuring instruments for pressure

Transmitters for gage, absolute and differential pressure, flow and level

DS III series for level

2

SITRANS P, DS III series for level

	HART	PROFIBUS PA or FOUNDATION Fieldbus
Certificate and approvals		
Classification according to pressure equipment directive (DRGL 97/23/EC)	For gases of fluid group 1 and liquids of fluid group 1; complies with requirements of Article 3, paragraph 3 (sound engineering practice)	
Explosion protection		
• Intrinsic safety "i"	PTB 99 ATEX 2122	
- Identification	Ex II 1/2 G EEx ia/ib IIB/IIC T6	
- Permissible ambient temperature	-40 ... +85 °C (-40 ... +185 °F) temperature class T4; -40 ... +70 °C (-40 ... +158 °F) temperature class T5; -40 ... +60 °C (-40 ... +140 °F) temperature class T6	
- Connection	To certified intrinsically-safe circuits with maximum values: $U_i = 30 \text{ V}$, $I_i = 100 \text{ mA}$, $P_i = 750 \text{ mW}$; $R_i = 300 \Omega$	FISCO supply unit: $U_o = 17.5 \text{ V}$, $I_o = 380 \text{ mA}$, $P_o = 5.32 \text{ W}$ Linear barrier: $U_o = 24 \text{ V}$, $I_o = 250 \text{ mA}$, $P_o = 1.2 \text{ W}$
- Effective internal inductance/capacitance	$L_i = 0.4 \text{ mH}$, $C_i = 6 \text{ nF}$	$L_i = 7 \mu\text{H}$, $C_i = 1.1 \text{ nF}$
• Explosion-proof "d"	PTB 99 ATEX 1160	
- Identification	Ex II 1/2 G EEx d IIC T4/T6	
- Permissible ambient temperature	-40 ... +85 °C (-40 ... +185 °F) temperature class T4; -40 ... +60 °C (-40 ... +140 °F) temperature class T6	
- Connection	To circuits with values: $U_H = 10.5 \dots 45 \text{ V DC}$	To circuits with values: $U_H = 9 \dots 32 \text{ V DC}$
• Dust explosion protection for zone 20	PTB 01 ATEX 2055	
- Identification	Ex II 1 D IP65 T 120 °C Ex II 1/2 D IP65 T 120 °C	
- Permissible ambient temperature	-40 ... +85 °C (-40 ... +185 °F)	
- Max. surface temperature	120 °C (248 °F)	
- Connection	To certified intrinsically-safe circuits with maximum values: $U_i = 30 \text{ V}$, $I_i = 100 \text{ mA}$, $P_i = 750 \text{ mW}$, $R_i = 300 \Omega$	FISCO supply unit: $U_o = 17.5 \text{ V}$, $I_o = 380 \text{ mA}$, $P_o = 5.32 \text{ W}$ Linear barrier: $U_o = 24 \text{ V}$, $I_o = 250 \text{ mA}$, $P_o = 1.2 \text{ W}$
- Effective internal inductance/capacitance	$L_i = 0.4 \text{ mH}$, $C_i = 6 \text{ nF}$	$L_i = 7 \mu\text{H}$, $C_i = 1.1 \text{ nF}$
• Dust explosion protection for zone 21/22	PTB 01 ATEX 2055	
- Identification	Ex II 2 D IP65 T 120 °C	
- Connection	To circuits with values: $U_H = 10.5 \dots 45 \text{ V DC}$; $P_{\max} = 1.2 \text{ W}$	To circuits with values: $U_H = 9 \dots 32 \text{ V DC}$; $P_{\max} = 1.2 \text{ W}$
• Type of protection "n" (zone 2)	TÜV 01 ATEX 1696 X	Planned
- Identification	Ex II 3 G EEx nA L IIC T4/T5/T6	-
• Explosion protection to FM	Certificate of Compliance 3008490	
- Identification (XP/DIP) or (IS); (NI)	CL I, DIV 1, GP ABCD T4...T6; CL II, DIV 1, GP EFG; CL III; CL I, ZN 0/1 AEx ia IIC T4...T6; CL I, DIV 2, GP ABCD T4...T6; CL II, DIV 2, GP FG; CL III	
• Explosion protection to CSA	Certificate of Compliance 1153651	
- Identification (XP/DIP) or (IS)	CL I, DIV 1, GP ABCD T4...T6; CL II, DIV 1, GP EFG; CL III; Ex ia IIC T4...T6; CL I, DIV 2, GP ABCD T4...T6; CL II, DIV 2, GP FG; CL III	

SITRANS P measuring instruments for pressure

Transmitters for gage, absolute and differential pressure, flow and level

DS III series
for level

2

HART communication

HART communication	230 ... 1100 Ω
Protocol	HART Version 5.x
Software for computer	SIMATIC PDM

PROFIBUS PA communication

Simultaneous communication with master class 2 (max.)	4
The address can be set using	Configuration tool or local operation (standard setting address 126)
Cyclic data usage	
• Output byte	5 (one measuring value) or 10 (two measuring values)
• Input byte	0, 1, or 2 (register operating mode and reset function for metering)
Internal preprocessing	
Device profile	PROFIBUS PA Profile for Process Control Devices Version 3.0, Class B
Function blocks	2
• Analog input	
- Adaptation to customer-specific process variables	Yes, linearly rising or falling characteristic
- Electrical damping T_{63} , adjustable	0 ... 100 s
- Simulation function	Input /Output
- Failure mode	Can be parameterized (last good value, substitute value, incorrect value)
- Limit monitoring	Yes, one upper and lower warning limit and one alarm limit respectively
• Register (totalizer)	Can be reset, preset, optional direction of counting, simulation function of register output
- Failure mode	Can be parameterized (summation with last good value, continuous summation, summation with incorrect value)
- Limit monitoring	One upper and lower warning limit and one alarm limit respectively
• Physical block	1
Transducer blocks	2
• Pressure transducer block	
- Can be calibrated by applying two pressures	Yes
- Monitoring of sensor limits	Yes
- Specification of a container characteristic with	Max. 30 nodes
- Square-rooted characteristic for flow measurement	Yes
- Gradual volume suppression and implementation point of square-root extraction	Parameterizable
- Simulation function for measured pressure value and sensor temperature	Constant value or over parameterizable ramp function

Communication FOUNDATION Fieldbus

Function blocks	3 function blocks analog input, 1 function block PID
• Analog input	
- Adaptation to customer-specific process variables	Yes, linearly rising or falling characteristic
- Electrical damping T_{63} , adjustable	0 ... 100 s
- Simulation function	Output/input (can be locked within the device with a bridge)
- Failure mode	Can be parameterized (last good value, substitute value, incorrect value)
- Limit monitoring	Yes, one upper and lower warning limit and one alarm limit respectively
- Square-rooted characteristic for flow measurement	Yes
• PID	Standard FF function block
• Physical block	1 Resource block
Transducer blocks	1 transducer block Pressure with calibration, 1 transducer block LCD
• Pressure transducer block	
- Can be calibrated by applying two pressures	Yes
- Monitoring of sensor limits	Yes
- Simulation function: Measured pressure value, sensor temperature and electronics temperature	Constant value or over parameterizable ramp function

Mounting flange

Nom. diam.	Nom. press.
• To EN 1092-1	
- DN 80	PN 40
- DN 100	PN16, PN40
• To ASME B16.5	
- 3 inch	Class 150, class 300
- 4 inch	Class 150, class 300

SITRANS P measuring instruments for pressure

Transmitters for gage, absolute and differential pressure, flow and level

DS III series for level

2

Selection and Ordering data		Order No.
SITRANS P pressure transmitters for level series DS III HART		7MF4633-
		Y -
Measuring cell filling	Measuring cell cleaning	
Silicone oil	Standard	1
Span		
25 ... 250 mbar	(0.363 ... 3.63 psi)	D
25 ... 600 mbar	(0.363 ... 8.70 psi)	E
53 ... 1600 mbar	(0.77 ... 23.2 psi)	F
0.16 ... 5 bar	(2.32 ... 72.5 psi)	G
Process connection of low-pressure side		
Female thread 1/4-18 NPT with flange connection		
• Mounting thread M10 to DIN 19213		0
• Mounting thread 7/16-20 UNF to EN 61518		2
Non-wetted parts materials		
Process flange screws	Electronics housing	
Stainless steel	Die-cast aluminium	2
Stainless steel	Stainless steel precision casting ¹⁾	3
Version		
• Standard version		1
• International version, English label inscriptions, documentation in 5 languages on CD		2
Explosion protection		
• Without		A
• With ATEX, Type of protection:		
- "Intrinsic safety (Ex ia)"		B
- "Explosion-proof (Ex d)" ²⁾		D
- "Intrinsic safety and explosion-proof enclosure (Ex ia + Ex d)" ³⁾		P
- "Ex nA/nL (zone 2)"		E
- "Intrinsic safety, explosion-proof enclosure and dust explosion protection (Ex ia + Ex d + Zone 1D/2D)" ³⁾		R
• With FM + CSA, Type of protection:		
- "Intrinsic safety and explosion-proof (is + xp)" ²⁾		NC
Electrical connection / cable entry		
• Screwed gland Pg 13.5 ⁴⁾		A
• Screwed gland M20x1.5		B
• Screwed gland 1/2-14 NPT		C
• Han 7D plug (plastic housing) incl. mating connector ⁴⁾		D
• M12 connectors (metal) ⁵⁾		F
Display		
• without (digital indicator hidden, setting: mA)		1
• With visible digital indication		6
• With customer-specific digital indication (setting as specified, Order code "Y21" or required)		7

Ordering information:

1st order item: Pressure transmitter 7MF4633-...

2nd order item: Mounting flange 7MF4912-3...

Ordering example:

Item line 1: 7MF4633-1EY20-1AA1-Z

B line: Y01

C line: Y01: 80 to 143 mbar (1.16 to 2.1 psi)

Item line 2: 7MF4912-3GE01

Power supply units see "SITRANS I power supply units and isolation amplifiers".

Included in delivery of the device:

- Brief instructions (Leporello)
- CD-ROM with detailed documentation
- Sealing plug(s) or sealing screw(s) for the process flanges(s)

- 1) Not together with Electrical connection „Screwed gland Pg 13.5“ and „Han7D plug“.
 - 2) Without cable gland, with blanking plug.
 - 3) With enclosed cable gland Ex ia and blanking plug.
 - 4) Not together with type of protection "Explosion-proof" and type of protection "Ex nA".
 - 5) Not together with types of protection "Explosion-proof" or "Intrinsic safety and explosion-proof"
- F) Subject to export regulations AL: 9I999, ECCN: N.

SITRANS P measuring instruments for pressure

Transmitters for gage, absolute and differential pressure, flow and level

DS III series
for level

2

Selection and Ordering data		Order No.	Selection and Ordering data		Order code
SITRANS P pressure transmitter for level			Further designs		
DS III PA series (PROFIBUS PA)		7 MF 4 6 3 4 -	Add "-Z" to Order No. and specify Order code.		HART PA FF
DS III FF series (FOUNDATION Fieldbus)		7 MF 4 6 3 5 -	O-rings for process flanges on low-pressure side (instead of FPM (Viton))		
		1 ■ Y ■ ■ - ■ ■ ■ ■	• PTFE (Teflon)		A20 ✓ ✓ ✓
Nominal measuring range			• FEP (with silicone core, approved for food)		A21 ✓ ✓ ✓
250 mbar (3.63 psi)		D	• FPM (Kalrez, compound 4079)		A22 ✓ ✓ ✓
600 mbar (8.70 psi)		E	• NBR (Buna N)		A23 ✓ ✓ ✓
1600 mbar (23.2 psi)		F	Plug		
5 bar (72.5 psi)		G	• Han 7D (metal, gray)		A30 ✓
Process connection of low-pressure side			• Han 8U (instead of Han 7D)		A31 ✓
Female thread 1/4-18 NPT with flange connection			Sealing screws		
• Mounting thread M10 to DIN 19213		0	1/4-18 NPT, with valve in material of process flanges		A40 ✓ ✓ ✓
• Mounting thread 7/16-20 UNF to EN 61518		2	Cable sockets for M12 connectors (metal)		A50 ✓ ✓ ✓
Non-wetted parts materials			Rating plate inscription (instead of German)		
Process flange screws Electronics housing			• English		B11 ✓ ✓ ✓
Stainless steel Die-cast aluminium		2	• French		B12 ✓ ✓ ✓
Stainless steel Stainless steel precision casting		3	• Spanish		B13 ✓ ✓ ✓
Version			• Italian		B14 ✓ ✓ ✓
• Standard version		1	English rating plate		B21 ✓ ✓ ✓
• International version, English label inscriptions, documentation in 5 languages on CD		2	Pressure units in inH ₂ O or psi		
Explosion protection			Manufacturer's test certificate M		C11 ✓ ✓ ✓
• Without			To DIN 55350, Part 18 and to ISO 8402		
• With CENELEC, Type of protection:			Acceptance test certificate		C12 ✓ ✓ ✓
- "Intrinsic safety (EEx ia)"			To EN 10204-3.1		
- "Explosion-proof (EEx d) ¹⁾ "		F)	Factory certificate		C14 ✓ ✓ ✓
- "Intrinsic safety and explosion-proof enclosure (EEx ia + EEx d) ²⁾ "		F)	To EN 10204-2.2		
- "Ex nA/nL (zone2)"			"Functional Safety (SIL)" certificate		C20 ✓
- "Intrinsic safety, explosion-proof enclosure and dust explosion protection (EEx ia + EEx d + Zone 1D/2D) ²⁾ (not for DS III FF)		F)	"PROFIsafe" certificate and protocol		C21 ✓
• With FM + CSA, Type of protection:			Setting of upper limit of output signal to 22.0 mA		D05 ✓
- "Intrinsic safety and explosion-proof (is + xp) ²⁾ "		F)	Type of protection IP68		D12 ✓ ✓ ✓
			(not together with PROFIBUS plug M12)		
Electrical connection / cable entry			Supplied with oval flange		D37 ^{F)} ✓ ✓ ✓
• Screwed gland M20x1.5			(1 item), PTFE packing and stainless steel screws in thread of process flange		
• Screwed gland 1/2-14 NPT			Use on zone 1D / 2D		E01 ✓ ✓ ✓
• Plug M12 incl. mating connector ³⁾			(only together with type of protection "Intrinsic safety (EEx ia)")		
Display			Use on zone 0		E02 ✓ ✓ ✓
• Without (digital display hidden)			(only together with type of protection "Intrinsic safety (EEx ia)")		
• With visible digital indication		1	Overfilling safety device for flammable and non-flammable liquids		E08 ✓ ✓
• With customer-specific digital indication (setting as specified, Order code "Y21" or required)		6	(max. PN 32 (MVWP 464 psi), basic device with type of protection "Intrinsic safety (EEx ia)")		
		7	Explosion-proof "Intrinsic safety" to INMETRO (Brazil)		E25 ✓ ✓ ✓
			(only for transmitter 7MF4...-.....-B..)		
			Explosion-proof "Intrinsic safety" to NEPSI (China)		E55 ✓ ✓ ✓
			(only for transmitter 7MF4...-.....-B..)		
			Explosion protection "Explosion-proof" to NEPSI (China)		E56 ✓ ✓ ✓
			(only for transmitter 7MF4...-.....-D..)		
			Explosion-proof "Zone 2" to NEPSI (China)		E57 ✓ ✓ ✓
			(only for transmitter 7MF4...-.....-E..)		
			Interchanging of process connection side		H01 ✓ ✓ ✓
Ordering information:					
1st order item: Pressure transmitter 7MF4634-...					
2nd order item: Mounting flange 7MF4912-...					
Ordering example:					
Item line 1: 7MF4634-1EY20-1AA1					
Item line 2: 7MF4912-3GE01					
Included in delivery of the device:					
• Brief instructions (Leporello)					
• CD-ROM with detailed documentation					
• Sealing plug(s) or sealing screw(s) for the process flanges(s)					
1) Without cable gland, with blanking plug.					
2) With enclosed cable gland EEx ia and blanking plug.					
3) Not together with types of protection "Explosion-proof" and "Intrinsic safety and explosion-proof"					
F) Subject to export regulations AL: 9I999, ECCN: N.					

SITRANS P measuring instruments for pressure

Transmitters for gage, absolute and differential pressure, flow and level

DS III series for level

2

Selection and Ordering data		Order code			Selection and Ordering data		Order No.Ord. code	
Additional data		HART	PA	FF	Mounting flange		7 MF 4 9 1 2 -	
Add "-Z" to Order No. and specify Order code.					Directly mounted on the SITRANS P pressure transmitter (converter part) for level, for DS III series		3	
Measuring range to be set Specify in plain text (max. 5 digits): Y01: ... up to ... mbar, bar, kPa, MPa, psi	Y01	✓			Connection acc. to EN 1092-1			
Measuring point number (TAG No.) Max. 16 characters, specify in plain text: Y15:	Y15	✓	✓	✓	Nom. diam. DN 80 DN 100		D G H	
Measuring point text Max. 27 characters, specify in plain text: Y16:	Y16	✓	✓	✓	Nom. press. PN 40 PN 16 PN 40			
Entry of HART address (TAG) Max. 8 characters, specify in plain text: Y17:	Y17	✓			Connection acc. to ASME B16.5		Q R T U Z	
Setting of pressure indicator in pressure units Specify in plain text (standard setting: mA): Y21: mbar, bar, kPa, MPa, psi, ... Note: The following pressure units can be selected: bar, mbar, mm H ₂ O ¹⁾ , inH ₂ O ¹⁾ , ftH ₂ O ¹⁾ , mmHG, inHG, psi, Pa, kPa, MPa, g/cm ² , kg/cm ² , Torr, ATM or %) ref. temperature 20 °C	Y21	✓	✓	✓	Nom. diam. 3 inch 4 inch Other version, add Order code and plain text: Nominal diameter: ...; Nominal pressure: ...		J 1 Y	
Setting of pressure indicator in non-pressure units Specify in plain text: Y22: up to l/min, m ³ /h, m, USgpm, ... (specification of measuring range in pressure units "Y01" is essential, unit with max. 5 characters)	Y22¹⁾ + Y01	✓			Wetted parts materials		A D E 0 F G H J U K Z	
Preset bus address Specify in plain text (standard setting: 126) Y25:	Y25		✓		<ul style="list-style-type: none"> Stainless steel 316L <ul style="list-style-type: none"> - Coated with PFA - Coated with PTFE - Coated with ECTFE¹⁾ Monel 400, mat. No. 2.4360 Hastelloy B2, mat. No. 2.4617 Hastelloy C276, mat. No. 2.4819 Hastelloy C4, mat. No. 2.4610 Tantalum Other version, add Order code and plain text: material of parts in contact with the medium: ... Sealing face, see "Technical specifications"		K 1 Y	
Only "Y01", "Y21", "Y22", "Y25" and "D05" can be factory preset					Tube length		0 1 2 3 4 9	
✓ = available					<ul style="list-style-type: none"> Without 50 mm (1.97 inch) 100 mm (3.94 inch) 150 mm (5.90 inch) 200 mm (7.87 inch) Other version: add Order code and plain text: Tube length: ...		L 1 Y	
1) Not together with over-filling safety device for flammable and non-flammable liquids (Order code "E08")					Filling liquid		1 2 3 4 6 7 9	
					<ul style="list-style-type: none"> Silicone oil M5 Silicone oil M50 High-temperature oil Halocarbon oil (for O₂ measurements) Glycerin / water²⁾ Food oil (FDA-listed) Other version, add Order code and plain text: filling liquid: ...		M 1 Y	

1) For vacuum on request
2) Not suitable for use in low-pressure range

SITRANS P measuring instruments for pressure

Transmitters for gage, absolute and differential pressure, flow and level

DS III series
for level

2

Selection and Ordering data	Order code		
<i>Further designs</i>		HART	PA and FF
Add "-Z" to Order No. and specify Order code.			
Flame flashover lock-out For mounting on zone 0 (including documentation)	A01	✓	✓
Manufacturer's test certificate M To DIN 55350, Part 18 and to ISO 8402	C11	✓	✓
Acceptance test certificate To EN 10204-3.1	C12	✓	✓
Vacuum-proof design (for use in low-pressure range)	V04	✓	✓
Calculation of span of associated pressure transmitter (enclose filled-in questionnaire with order) Note: suffix "Y01" required with pressure transmitter!	Y05	✓	✓

✓ = available

SITRANS P measuring instruments for pressure

Transmitters for gage, absolute and differential pressure, flow and level

DS III series
for level

Dimensional drawings

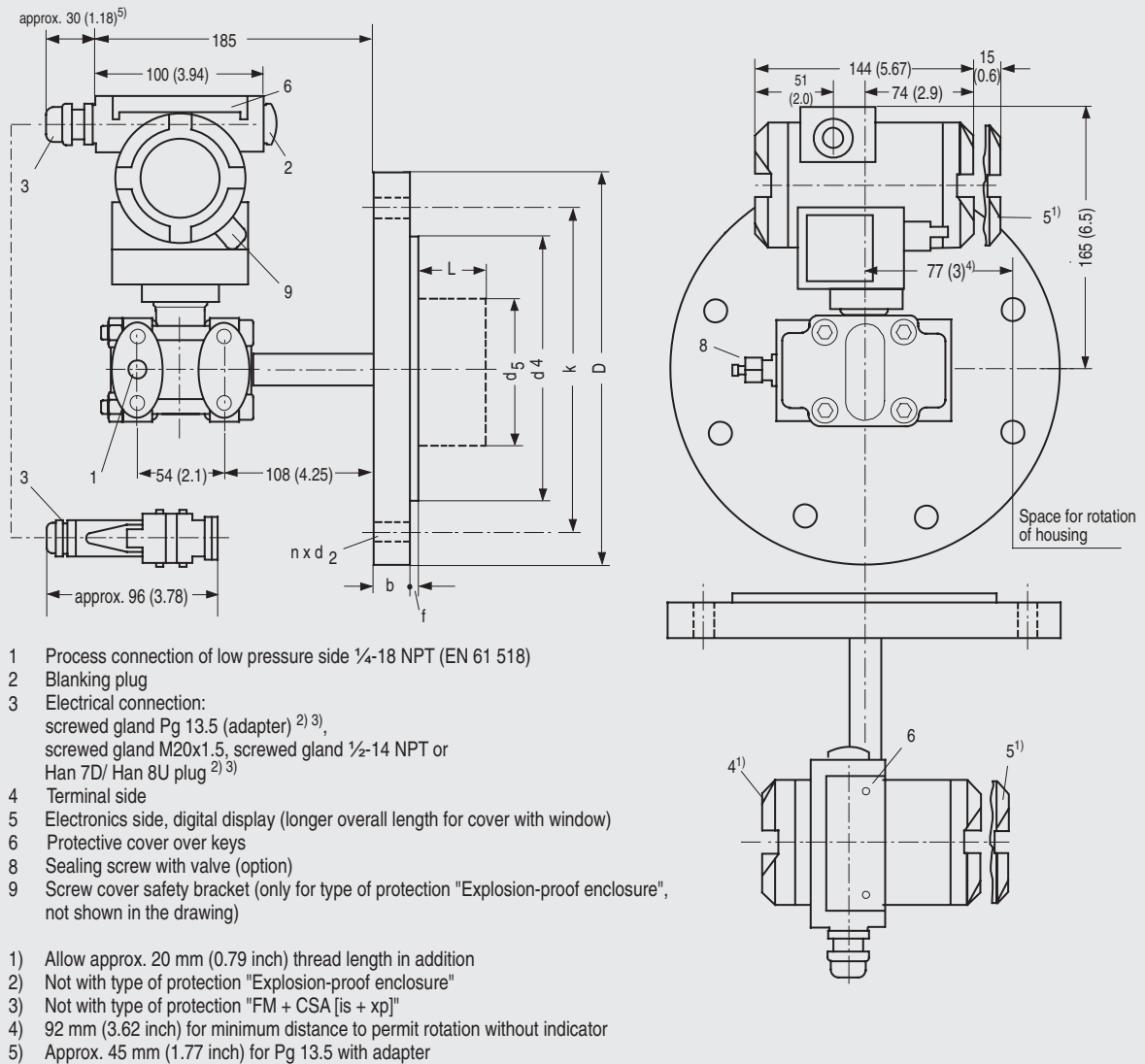

SITRANS P pressure transmitters, DS III HART series for level, including mounting flange, dimensions in mm (inch)

Connection to EN 1092-1

Nom. diam.	Nom. press.	b	D	d	d ₂	d ₄	d ₅	d _M	f	k	n	L
		mm	mm	mm	mm	mm	mm	mm	mm	mm	mm	mm
DN 80	PN 40	24	200	90	18	138	76	72 ¹⁾	2	160	8	0, 50, 100,
DN 100	PN 40	20	220	115	18	158	94	89	2	180	8	150 or 200
	PN 40	24	235	115	22	162	94	89	2	190	8	

Connection to ASME B16.5

Nom. diam.	Nom. press.	b	D	d ₂	d ₄	d ₅	d _M	f	k	n	L
	lb/sq.in.	inch	inch	inch	inch	inch	inch	inch	inch		inch
		(mm)	(mm)	(mm)	(mm)	(mm)	(mm)	(mm)	(mm)		(mm)
3 inch	150	0.94 (23.8)	7.5 (190.5)	0.75 (19.0)	5 (127)	3 (76)	2.81 ¹⁾ (72)	0.06 (1.6)	6 (152.4)	4	0, 2, 3.94, 5.94 or 7.87 (0, 50, 100, 150 or 200)
	300	1.12 (28.6)	8.25 (209.5)	0.87 (22.2)	5 (127)	3 (76)	2.81 ¹⁾ (72)	0.06 (1.6)	6.69 (168.3)	8	
4 inch	150	0.94 (23.8)	9 (228.5)	0.75 (19.0)	6.19 (157.2)	3.69 (94)	3.5 (89)	0.06 (1.6)	7.5 (190.5)	8	
	300	1.25 (31.7)	10 (254)	0.87 (22.2)	6.19 (157.2)	3.69 (94)	3.5 (89)	0.06 (1.6)	7.88 (200)	8	

d: Internal diameter of gasket to DIN 2690
 d_M: Effective diaphragm diameter

¹⁾ 89 mm = 3½ inch with tube length L = 0.

SITRANS P measuring instruments for pressure

Transmitters for gage, absolute and differential pressure, flow and level

DS III series
for level

2

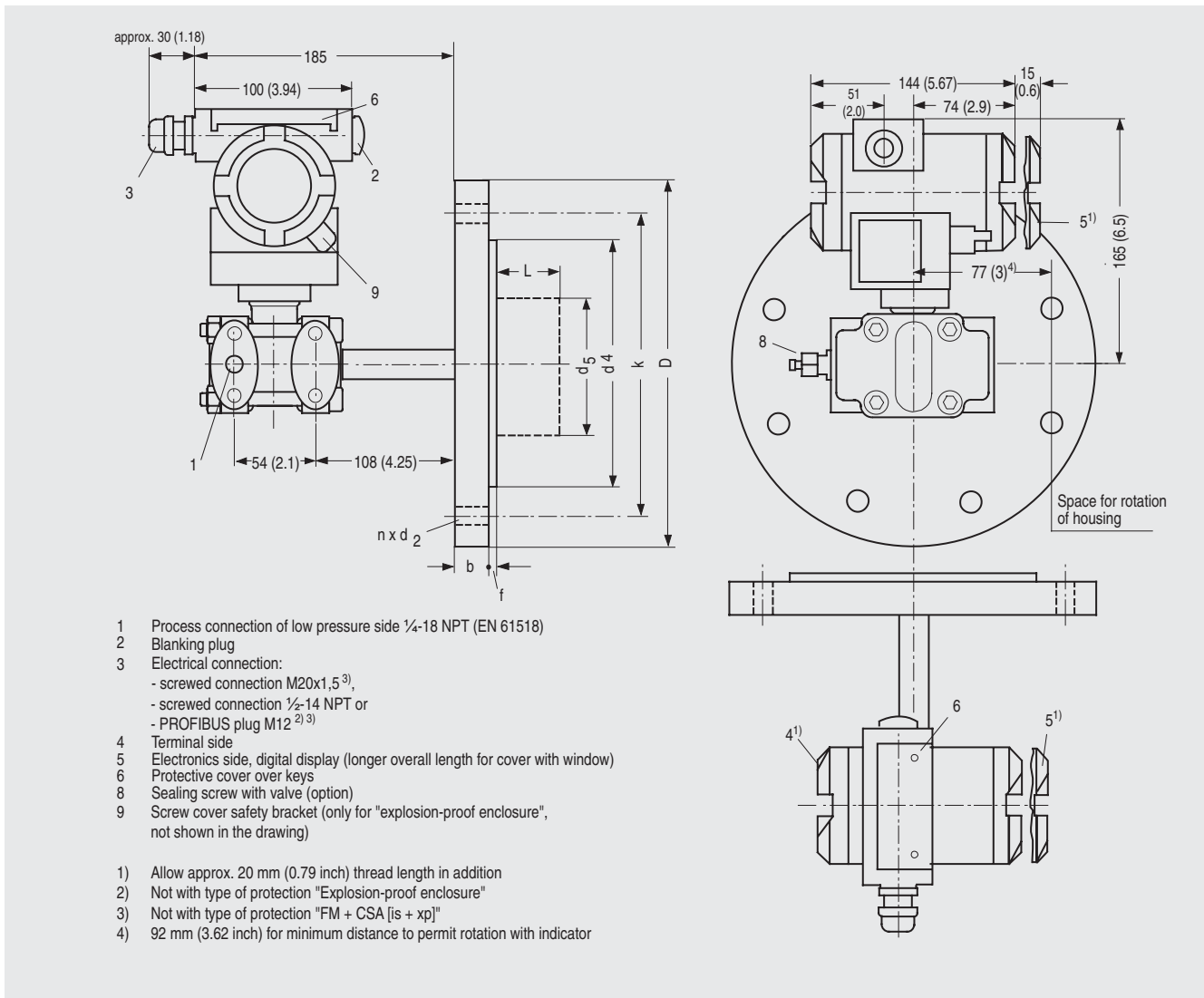

SITRANS P pressure transmitters, DS III PA and FF series for level, including mounting flange, dimensions in mm (inch)

Connection to EN 1092-1

Nom. diam.	Nom. press.	b	D	d	d ₂	d ₄	d ₅	d _M	f	k	n	L
		mm	mm	mm	mm	mm	mm	mm	mm	mm	mm	mm
DN 80	PN 40	24	200	90	18	138	76	72 ¹⁾	2	160	8	0, 50, 100, 150 or 200
DN 100	PN 40	20	220	115	18	158	94	89	2	180	8	
	PN 40	24	235	115	22	162	94	89	2	190	8	

Connection to ASME B16.5

Nom. diam.	Nom. press.	b	D	d ₂	d ₄	d ₅	d _M	f	k	n	L
	lb/sq.in.	inch	inch	inch	inch	inch	inch	inch	inch		inch
		(mm)	(mm)	(mm)	(mm)	(mm)	(mm)	(mm)	(mm)		(mm)
3 inch	150	0.94 (23.8)	7.5 (190.5)	0.75 (19.0)	5 (127)	3 (76)	2.81 ¹⁾ (72)	0.06 (1.6)	6 (152.4)	4	0, 2, 3.94, 5.94 or 7.87 (0, 50, 100, 150 or 200)
	300	1.12 (28.6)	8.25 (209.5)	0.87 (22.2)	5 (127)	3 (76)	2.81 ¹⁾ (72)	0.06 (1.6)	6.69 (168.3)	8	
4 inch	150	0.94 (23.8)	9 (228.5)	0.75 (19.0)	6.19 (157.2)	3.69 (94)	3.5 (89)	0.06 (1.6)	7.5 (190.5)	8	
	300	1.25 (31.7)	10 (254)	0.87 (22.2)	6.19 (157.2)	3.69 (94)	3.5 (89)	0.06 (1.6)	7.88 (200)	8	

d: Internal diameter of gasket to DIN 2690
d_M: Effective diaphragm diameter

¹⁾ 89 mm = 3½ inch with tube length L = 0.