

ST 3000 Smart Transmitter Series 900 Gauge Pressure Models

STG944	0 to 500 psi	0 to 35 bar
STG94L	0 to 500 psi	0 to 35 bar
STG974	0 to 3000 psi	0 to 210 bar
STG97L	0 to 3000 psi	0 to 210 bar
STG98L	0 to 6000 psi	0 to 415 bar

34-ST-03-67
2/00

Specification and Model Selection Guide

Function

Honeywell's ST 3000® Series 900 Gauge Pressure Transmitters bring proven "smart" technology to a wide spectrum of gauge pressure measurement applications with varying process interface requirements. They transmit an output signal proportional to the measured variable in either an analog 4 to 20 milliampere format or in a digital DE protocol format for direct digital integration with our TDC 3000®X control system. Additional protocol options available for the ST 3000 Series 900 transmitters include FOUNDATION™ Fieldbus¹ and HART®². See the Model Selection Guide for help in selecting the correct ordering code for the desired protocol.

In the standard transmitter you easily select the analog or digital transmission format through the Smart Field Communicator (SFC®) which is the common hand-held operator interface for our DE-based Smartline® Transmitters. All configuration, operation, and communications functions are under the control of the ST 3000 Smart Transmitter's microprocessor and are accessible through the SFC.

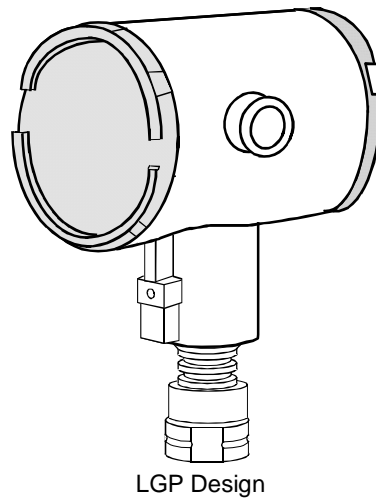

LGP Design

ST 3000 Gauge Pressure Transmitter

Models:
STG94L
STG97L
STG98L

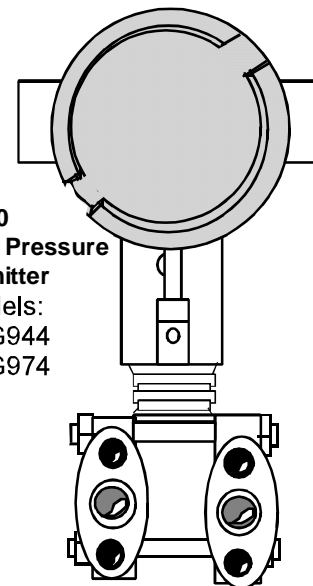

ST 3000 Gauge Pressure Transmitter

Models:
STG944
STG974

Dual-Head Design

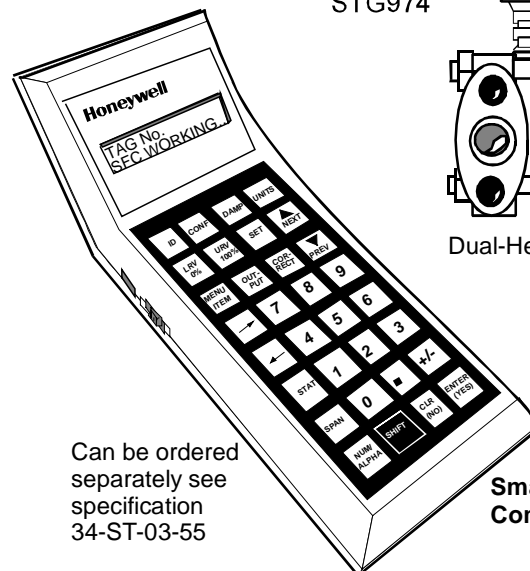

Can be ordered
separately see
specification
34-ST-03-55

Smart Field
Communicator

24251

¹ FOUNDATION™ Fieldbus is a trademark of the Fieldbus Foundation.

² HART is a registered trademark of the Hart Communication Foundation.

Figure 1—Series 900 Gauge Pressure Transmitters feature proven "smart" technology and come in dual-head and in-line models to meet varying application needs.

Features	Description	
<ul style="list-style-type: none"> • Choice of dual-head or in-line model to match process interface requirements. • Direct digital integration with TDC 3000^X system provides local measurement accuracy to the system level without adding typical A/D and D/A converter inaccuracies. • Unique piezoresistive sensor automatically compensates input for temperature. • Added “smart” features include configuring lower and upper range values, simulating accurate analog output, and selecting preprogrammed engineering units for display. • Smart transmitter capabilities with local or remote interfacing means significant manpower efficiency improvements in commissioning, start-up, and ongoing maintenance functions 	<p>The ST 3000 transmitter can replace any 4 to 20 milliampere output transmitter in use today, and operates over a standard two-wire system.</p>	<p>Like other Smartline Transmitters, the ST 3000 features two-way communication between the operator and the transmitter through our SFC. You can connect the SFC anywhere that you can access the transmitter signal lines, and it provides the capabilities of transmitter adjustments and diagnostics from remote locations, such as the control room.</p>
	<p>The measuring means is a piezoresistive sensor which actually contains a pressure sensor and a temperature sensor.</p>	<p>The transmitter’s meter body and electronics housing resist shock, vibration, corrosion, and moisture. The electronics housing contains a compartment for the single-board electronics, which is isolated from an integral junction box. The single-board electronics is replaceable and interchangeable with any other ST 3000 Series 900 or Series 100e model transmitter.</p>
	<p>Microprocessor-based electronics provide higher span-turndown ratio, improved temperature compensation, and improved accuracy.</p>	

Specifications

Operating Conditions – All Models

Parameter	Reference Condition (at zero static)		Rated Condition		Operative Limits		Transportation and Storage	
	°C	°F	°C	°F	°C	°F	°C	°F
Ambient Temperature	25 ±1	77 ±2	-40 to 70	-40 to 158	-40 to 85	-40 to 185	-55 to 125	-67 to 257
Meter Body Temperature	25 ±1	77 ±2	-40 to 110*	-40 to 230*	-40 to 125***	-40 to 257***	-55 to 125	-67 to 257
Humidity %RH	10 to 55		0 to 100		0 to 100		0 to 100	
Overpressure								
STG944, 94L psi	0		750		750			
bar	0		50		50			
STG974, 97L psi	0		4500		4500			
bar	0		310		310			
STG98L psi	0		9000		9000			
bar	0		620		620			
Vacuum Region - Minimum Pressure								
mmHg absolute	atmospheric		25		2 (short term**)			
inH₂O absolute	atmospheric		13		1 (short term**)			
Supply Voltage, Current, and Load Resistance	Voltage Range: 10.8 to 42.4 Vdc at terminals Current Range: 3.0 to 21.8 mA Load Resistance: 0 to 1440 ohms (as shown in Figure 2)							

* For model 944 with CTFE fill fluid, the rating is –15 to 70°C (5 to 158°F); for model 98L with CTFE fill fluid, the rating is –15 to 110°C (5 to 230°F).

**Short term equals 2 hours at 70°C (158 °F)

***For Models STG94L, STG97L, and STG98L, the upper limit is 110°C (230°F).

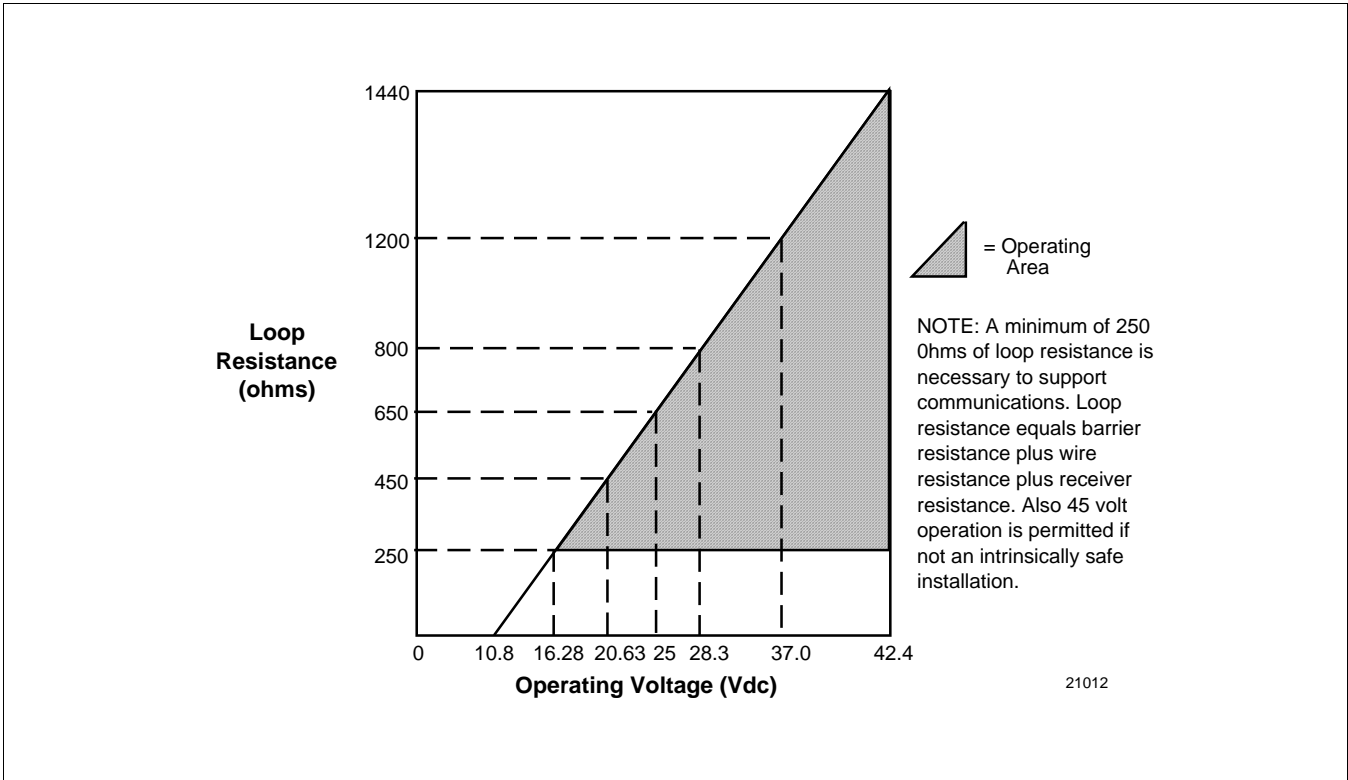

Figure 2—Supply voltage and loop resistance chart.

Performance Under Rated Conditions* - Models STG944 & 94L (0 to 500 psi/35 bar)

Parameter	Description
Upper Range Limit psi bar	500 35
Minimum Span psi bar	20 1.4
Turndown Ratio	25 to 1
Zero Elevation and Suppression	No limit except minimum span from absolute 0 (zero) to +100% URL. Specifications valid over this range.
<p>Accuracy (Reference – Includes combined effects of linearity, hysteresis, and repeatability)</p> <ul style="list-style-type: none"> • Accuracy includes residual error after averaging successive readings. • For FOUNDATION Fieldbus use Digital Mode specifications. For HART use Analog Mode specifications. 	<p>In Analog Mode: ±0.10% of calibrated span or upper range value (URV), whichever is greater, terminal based.</p> <p>For URV below reference point (20 psi), accuracy equals: $\pm 0.05 + 0.05 \left(\frac{20 \text{ psi}}{\text{span psi}} \right)$ or $\pm 0.05 + 0.05 \left(\frac{1.4 \text{ bar}}{\text{span bar}} \right)$ in % span</p> <p>In Digital Mode: ±0.075% of calibrated span or upper range value (URV), whichever is greater, terminal based.</p> <p>For URV below reference point (20 psi), accuracy equals: $\pm 0.025 + 0.05 \left(\frac{20 \text{ psi}}{\text{span psi}} \right)$ or $\pm 0.025 + 0.05 \left(\frac{1.4 \text{ bar}}{\text{span bar}} \right)$ in % span</p>
Zero Temperature Effect per 28°C (50°F)	<p>In Analog Mode: ±0.1625% of span.</p> <p>For URV below reference point (50 psi), effect equals: $\pm 0.0125 + 0.15 \left(\frac{50 \text{ psi}}{\text{span psi}} \right)$ or $\pm 0.0125 + 0.15 \left(\frac{3.5 \text{ bar}}{\text{span bar}} \right)$ in % span</p> <p>In Digital Mode: ±0.15% of span.</p> <p>For URV below reference point (50 psi), effect equals: $\pm 0.15 \left(\frac{50 \text{ psi}}{\text{span psi}} \right)$ or $\pm 0.15 \left(\frac{3.5 \text{ bar}}{\text{span bar}} \right)$ in % span</p>
Combined Zero and Span Temperature Effect per 28°C (50°F)	<p>In Analog Mode: ±0.25% of span.</p> <p>For URV below reference point (50 psi), effect equals: $\pm 0.10 + 0.15 \left(\frac{50 \text{ psi}}{\text{span psi}} \right)$ or $\pm 0.10 + 0.15 \left(\frac{3.5 \text{ bar}}{\text{span bar}} \right)$ in % span</p> <p>In Digital Mode: ±0.225% of span.</p> <p>For URV below reference point (50 psi), effect equals: $\pm 0.075 + 0.15 \left(\frac{50 \text{ psi}}{\text{span psi}} \right)$ or $\pm 0.075 + 0.15 \left(\frac{3.5 \text{ bar}}{\text{span bar}} \right)$ in % span</p>
Stability	±0.03% of URL per year

* Performance specifications are based on reference conditions of 25°C (77°F), 10 to 55% RH, and 316L Stainless Steel barrier diaphragm.

Performance Under Rated Conditions* - Models STG974 & 97L (0 to 3000 psi/210 bar)

Parameter	Description
Upper Range Limit psi bar	3000 210
Minimum Span psi bar	300 21
Turndown Ratio	10 to 1
Zero Elevation and Suppression	No limit except minimum span from absolute 0 (zero) to +100% URL. Specifications valid over this range.
<p>Accuracy (Reference – Includes combined effects of linearity, hysteresis, and repeatability)</p> <ul style="list-style-type: none"> • Accuracy includes residual error after averaging successive readings. • For FOUNDATION Fieldbus use Digital Mode specifications. For HART use Analog Mode specifications. 	<p>In Analog Mode: ±0.1% of calibrated span or upper range value (URV), whichever is greater, terminal based. For URV below reference point (750 psi), accuracy equals: ±0.05 + 0.05 $\left(\frac{750 \text{ psi}}{\text{span psi}}\right)$ or ±0.05 + 0.05 $\left(\frac{52 \text{ bar}}{\text{span bar}}\right)$ in % span</p> <p>In Digital Mode: ±0.075% of calibrated span or upper range value (URV), whichever is greater, terminal based. For URV below reference point (300 psi), accuracy equals: ±0.025 + 0.05 $\left(\frac{750 \text{ psi}}{\text{span psi}}\right)$ or ±0.025 + 0.05 $\left(\frac{52 \text{ bar}}{\text{span bar}}\right)$ in % span</p>
Zero Temperature Effect per 28°C (50°F)	<p>In Analog Mode: ±0.2125% of span. For URV below reference point (500 psi), effect equals: ±0.0125 + 0.20 $\left(\frac{500 \text{ psi}}{\text{span psi}}\right)$ or ±0.0125 + 0.20 $\left(\frac{35 \text{ bar}}{\text{span bar}}\right)$ in % span</p> <p>In Digital Mode: ±0.20% of span. For URV below reference point (500 psi), effect equals: ±0.20 $\left(\frac{500 \text{ psi}}{\text{span psi}}\right)$ or ±0.20 $\left(\frac{35 \text{ bar}}{\text{span bar}}\right)$ in % span</p>
Combined Zero and Span Temperature Effect per 28°C (50°F)	<p>In Analog Mode: ±0.325% of span. For URV below reference point (500 psi), effect equals: ±0.125 + 0.20 $\left(\frac{500 \text{ psi}}{\text{span psi}}\right)$ or ±0.125 + 0.20 $\left(\frac{35 \text{ bar}}{\text{span bar}}\right)$ in % span</p> <p>In Digital Mode: ±0.30% of span. For URV below reference point (500 psi), effect equals: ±0.10 + 0.20 $\left(\frac{500 \text{ psi}}{\text{span psi}}\right)$ or ±0.10 + 0.20 $\left(\frac{35 \text{ bar}}{\text{span bar}}\right)$ in % span</p>
Stability	±0.03% of URL per year

* Performance specifications are based on reference conditions of 25°C (77°F), 10 to 55% RH, and 316L Stainless Steel barrier diaphragm.

Performance Under Rated Conditions* - Model STG98L (0 to 6000 psi/415 bar)

Parameter	Description
Upper Range Limit psi bar	6000 415
Minimum Span psi bar	500 35
Turndown Ratio	12 to 1
Zero Elevation and Suppression	No limit except minimum span from absolute 0 (zero) to +100% URL. Specifications valid over this range.
Accuracy (Reference – Includes combined effects of linearity, hysteresis, and repeatability) <ul style="list-style-type: none"> • Accuracy includes residual error after averaging successive readings. • For FOUNDATION Fieldbus use Digital Mode specifications. For HART use Analog Mode specifications. 	<p>In Analog Mode: ±0.2% of calibrated span or upper range value (URV), whichever is greater, terminal based.</p> <p>For URV below reference point (1000 psi), accuracy equals: $\pm 0.05 + 0.15 \left(\frac{1000 \text{ psi}}{\text{span psi}} \right)$ or $\pm 0.05 + 0.15 \left(\frac{70 \text{ bar}}{\text{span bar}} \right)$ in % span</p> <p>In Digital Mode: ±0.175% of calibrated span or upper range value (URV), whichever is greater, terminal based.</p> <p>For URV below reference point (1000 psi), accuracy equals: $\pm 0.025 + 0.15 \left(\frac{1000 \text{ psi}}{\text{span psi}} \right)$ or $\pm 0.025 + 0.15 \left(\frac{70 \text{ bar}}{\text{span bar}} \right)$ in % span</p>
Zero Temperature Effect per 28°C (50°F)	<p>In Analog Mode: ±0.2125% of span.</p> <p>For URV below reference point (1000 psi), effect equals: $\pm 0.0125 + 0.20 \left(\frac{1000 \text{ psi}}{\text{span psi}} \right)$ or $\pm 0.0125 + 0.20 \left(\frac{70 \text{ bar}}{\text{span bar}} \right)$ in % span</p> <p>In Digital Mode: ±0.20% of span.</p> <p>For URV below reference point (1000 psi), effect equals: $\pm 0.20 \left(\frac{1000 \text{ psi}}{\text{span psi}} \right)$ or $\pm 0.20 \left(\frac{70 \text{ bar}}{\text{span bar}} \right)$ in % span</p>
Combined Zero and Span Temperature Effect per 28°C (50°F)	<p>In Analog Mode: ±0.325% of span.</p> <p>For URV below reference point (1000 psi), effect equals: $\pm 0.125 + 0.20 \left(\frac{1000 \text{ psi}}{\text{span psi}} \right)$ or $\pm 0.125 + 0.20 \left(\frac{70 \text{ bar}}{\text{span bar}} \right)$ in % span</p> <p>In Digital Mode: ±0.30% of span.</p> <p>For URV below reference point (1000 psi), effect equals: $\pm 0.10 + 0.20 \left(\frac{1000 \text{ psi}}{\text{span psi}} \right)$ or $\pm 0.10 + 0.20 \left(\frac{70 \text{ bar}}{\text{span bar}} \right)$ in % span</p>
Stability	±0.03% of URL per year

* Performance specifications are based on reference conditions of 25°C (77°F), 10 to 55% RH, and 316L Stainless Steel barrier diaphragm.

Performance Under Rated Conditions - General for all Models

Parameter	Description
Output (two-wire)	Analog 4 to 20 mA or DE digital communications mode. Options available for FOUNDATION Fieldbus and HART protocol.
Supply Voltage Effect	0.005% span per volt.
Damping Time Constant	Adjustable from 0 to 32 seconds digital damping.
CE Conformity (Europe)	89/336/EEC, Electromagnetic Compatibility (EMC) Directive.
Lightning Protection Option (Code "LP")	Leakage Current: 10 microamps max. @ 42.4 VDC, 93°C Impulse Rating: 10/20 μ sec. 5,000 Amps (50 strikes) 10,000 Amps (20 strikes) (rise/decay) 10/1000 μ sec. 250 Amps (1000 strikes) 500 Amps (400 strikes)

Physical and Approval Bodies

Parameter	Description
Barrier Diaphragms Material	Dual-Head Meter Body: 316L SS, Hastelloy C-276 In-Line Meter Body: 316L SS, Hastelloy C-276
Process Head Material	Dual-Head Meter Body: 316 SS, Carbon Steel (zinc-plated), Hastelloy. [Reference head is Carbon Steel (zinc-plated).] In-Line Meter Body: 316 SS process interface.
Head Gaskets	Teflon is standard. Viton is available.
Meter Body Bolting	Carbon Steel (Zinc plated, standard) or A286 SS (NACE) bolts and 302/304 SS (NACE) nuts for heads and 316 SS (NACE) bolts for adapters (standard option).
Mounting Bracket	Carbon Steel (Zinc-plated) or Stainless Steel angle bracket or Carbon Steel flat bracket available.
Fill Fluid	Silicone oil or CTFE (Chlorotrifluoroethylene)
Electronic Housing	Epoxy-Polyester hybrid paint. Low Copper-Aluminum. Meets NEMA 4X (watertight) and NEMA 7 (explosion proof). Stainless steel optional.
Process Connections	Dual-Head Meter Body: 1/4-inch NPT; 1/2-inch NPT with adapter or DIN, standard option. In-Line Meter Body: 1/2-inch NPT
Wiring	Accepts up to 16 AWG (1.5 mm diameter).
Mounting	Can be mounted in virtually any position using the standard mounting bracket. Bracket is designed to mount on 2-inch (50 mm) vertical or horizontal pipe. See Figure 3 for dual-head models, and Figure 4 for in-line models.
Dimensions	See Figures 5 and 6.
Net Weight	With Dual-Head Meter Body: 9 pounds (4.1 Kg) With In-Line Meter Body: 3.8 pounds (1.7 Kg)
Approval Bodies	Approved as explosion proof and intrinsically safe for use in Class I, Division 1, Groups A, B, C, D locations, and nonincendive for Class I, Division 2 Groups A, B, C, D locations. Approved EEx ia IIC T5 and EEx d IIC T6 per CENELEC standards; and Ex N II T5 per BS 6941. Series 900 with HC (HART) Compatibility is self certified for Zone 2, T5, maximum 42V/22 mA.

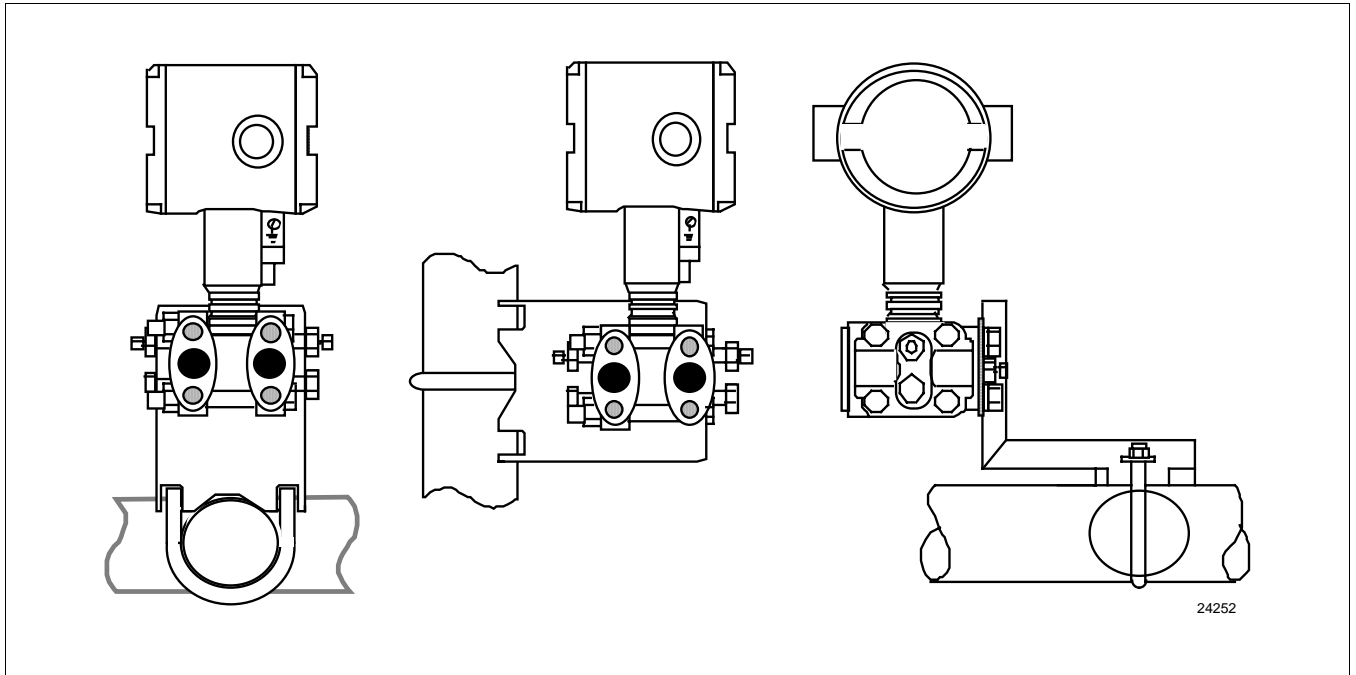

Figure 3—Examples of typical mounting positions for dual-head models STG944 and STG974

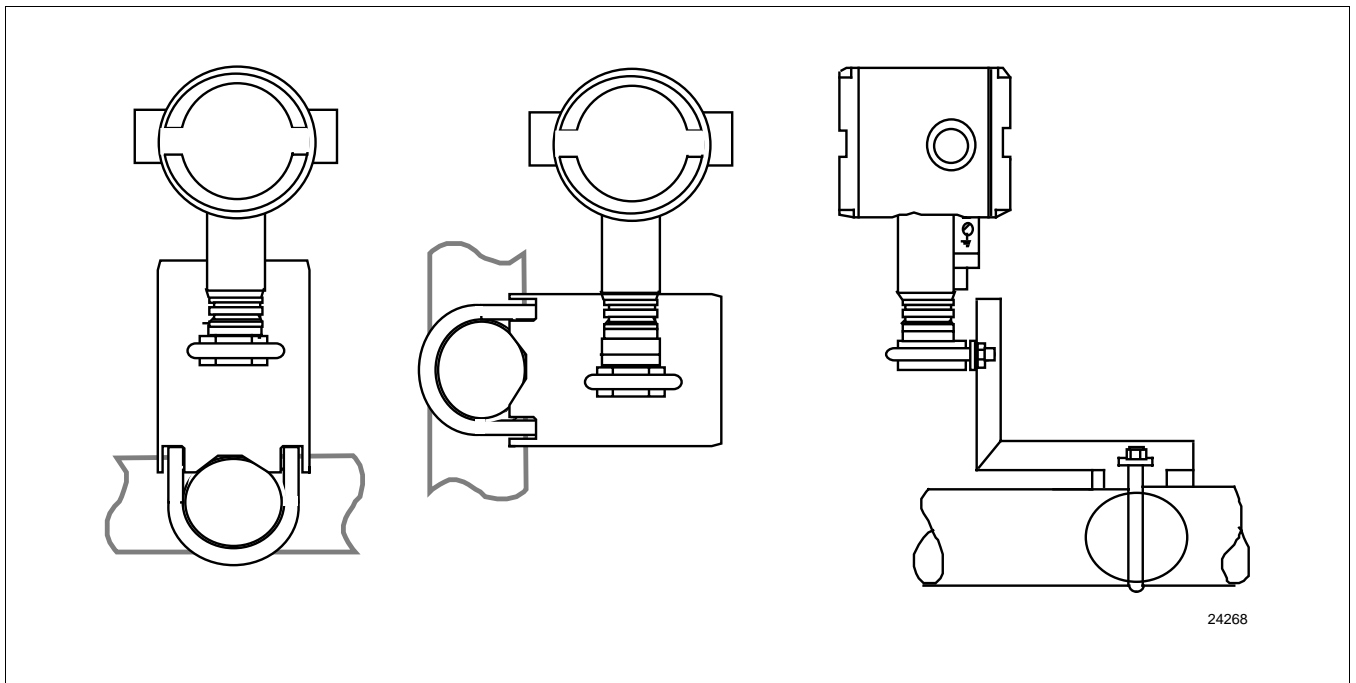
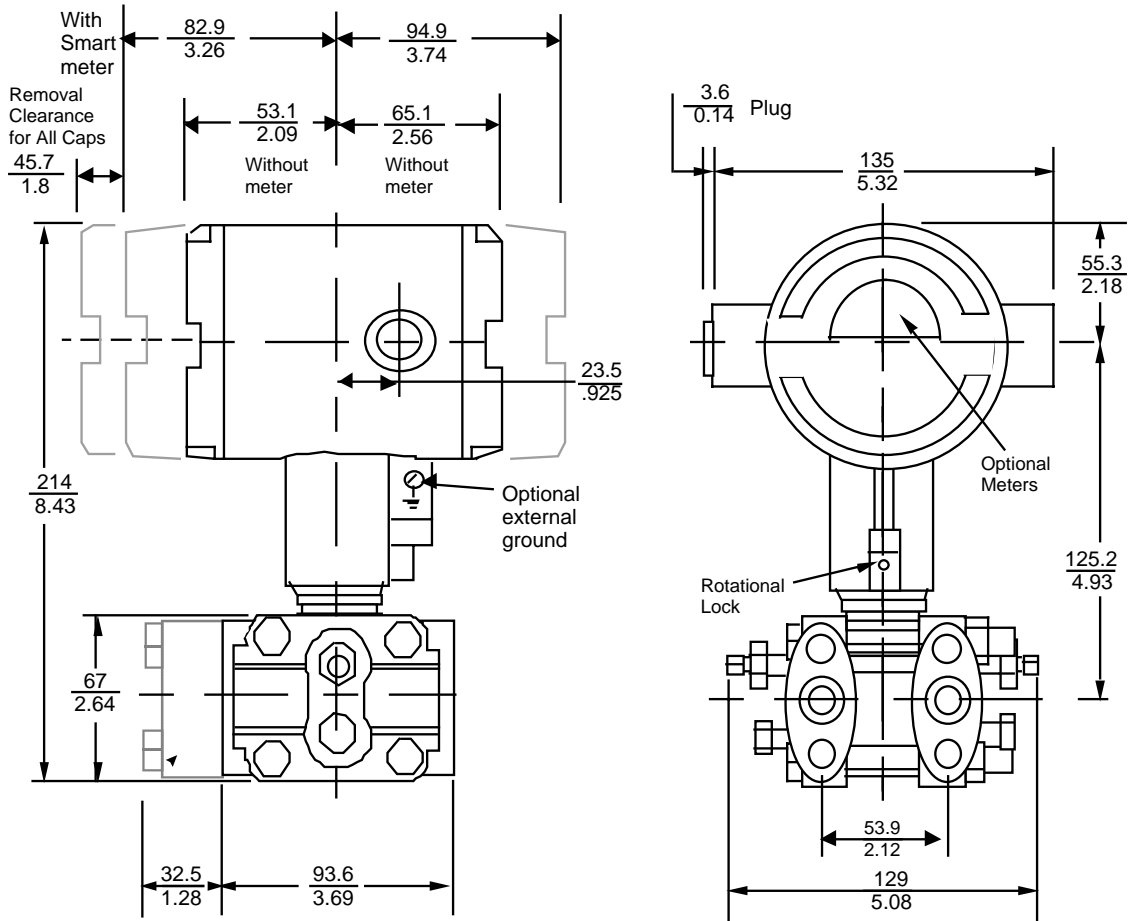

Figure 4—Examples of typical mounting positions for in-line models STG94L, STG97L, and STG98L. Note that a mounting bracket is not required for in-line models.

Reference Dimensions: $\frac{\text{millimeters}}{\text{inches}}$



24254

Figure 5—Typical mounting dimensions for dual-head models STG944 and STG974 for reference

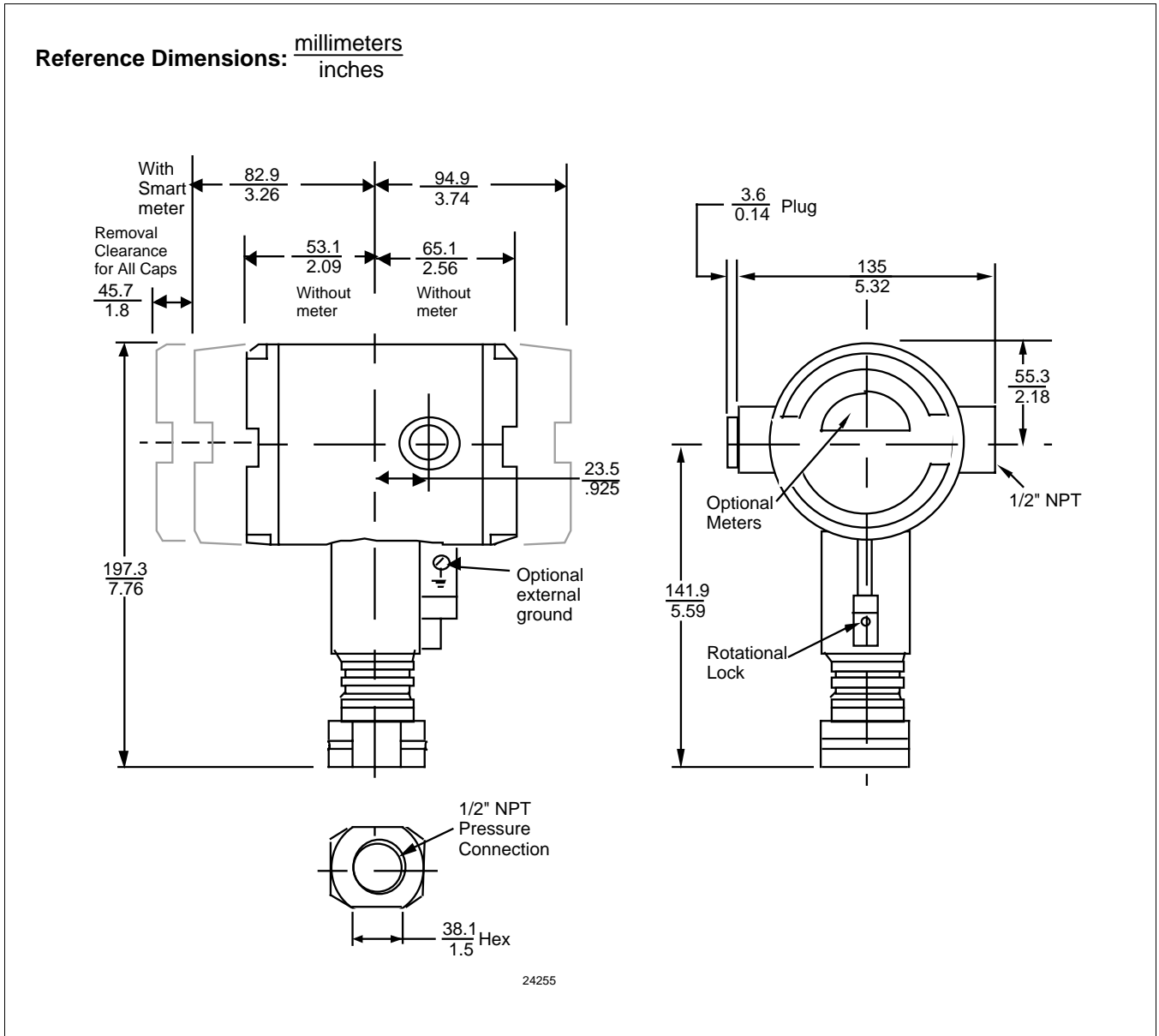

Figure 6—Typical mounting dimensions for in-line models STG94L, STG97L, and STG98L for reference

Options	Ordering Information
<p>Mounting Bracket The angle mounting bracket is available in either zinc-plated carbon steel or stainless steel and is suitable for horizontal or vertical mounting on a two inch (50 millimeter) pipe, as well as wall mounting. An optional flat mounting bracket is also available in carbon steel for two inch (50 millimeter) pipe mounting.</p> <p>Indicating Meter Two integral meter options are available. An analog meter (option ME) is available with a 0 to 100% linear scale. The Smart Meter (option SM) provides an LCD display for both analog and digital output and can be configured to display pressure in pre-selected engineering units.</p> <p>Lightning Protection A terminal block is available with circuitry that protects the transmitter from transient surges induced by nearby lightning strikes.</p> <p>HART Protocol Compatibility (Option HC) An optional electronics module is available for the Series 900 that provides HART Protocol compatibility. Transmitters with the HART Option are compatible with the AMS System. (Contact your AMS Supplier if an upgrade is required.)</p> <p>Configuration of the HART Option transmitter is accomplished using a Universal HART Communicator. For full functionality the communicator must contain the Honeywell Device Description (DD). Contact your nearest Honeywell office or distributor for further information regarding this option.</p> <p><i>Specifications are subject to change without notice. (Note that specifications may differ slightly for transmitters manufactured before October 30, 1995.)</i></p>	<p>Contact your nearest Honeywell sales office, or</p> <p>In the U.S.:</p> <p style="padding-left: 40px;">Honeywell Industrial Automation & Control 16404 N. Black Canyon Highway Phoenix, AZ 85023 1-800-288-7491</p> <p>In Canada:</p> <p style="padding-left: 40px;">The Honeywell Centre 155 Gordon Baker Rd. North York, Ontario M2H 3N7 1-800-461-0013</p> <p>In Latin America:</p> <p style="padding-left: 40px;">Honeywell Inc. 480 Sawgrass Corporate Parkway, Suite 200 Sunrise, FL 33325 (954) 845-2600</p> <p>In Europe:</p> <p style="padding-left: 40px;">Honeywell PACE 1, Avenue du Bourget B-1140 Brussels, Belgium [32-2] 728-2111</p> <p>In Asia:</p> <p style="padding-left: 40px;">Honeywell Asia Pacific Inc. Room 3213-25 Sun Hung Kai Centre No. 30 Harbour Road Wanchai, Hong Kong 2829-8298</p> <p>In the Pacific:</p> <p style="padding-left: 40px;">Honeywell Limited 5 Thomas Holt Drive North Ryde NSW 2113 Australia (61 2) 9353 7000</p> <p>Or, visit Honeywell on the World Wide Web at: http://www.honeywell.com</p>

Model Selection Guide

Instructions

- Select the desired Key Number. The arrow to the right marks the selection available.
- Make one selection from each table, I and II, using the column below the proper arrow. Select as many Table III options as desired (if no options are desired, specify 00). A dot denotes unrestricted availability. A letter denotes restricted availability. Restrictions follow Table IV.

Key Number - I - II - III (Optional) + IV
----- - --- - ----- - _,--- + XXXX

KEY NUMBER		Selection	Availability	
Span				
Gage	0-20 to 0-500 psi/0-1.4 to 0-35 bar	STG944	↓	
	0-300 to 0-3000 psi/0-21 to 0-210 bar	STG974	↓	
Pressure	0-20 to 0-500 psi/0-1.4 to 0-35 bar	STG94L		↓
	0-300 to 0-3000 psi/0-21 to 0-210 bar	STG97L		↓
	0-500 to 0-6000 psi/0-35 to 0-415 bar	STG98L		↓

TABLE I - METER BODY

	Wetted Process Head ***	Vent/Drain Valve **	Barrier Diaphragms		
Material of Construction	Carbon Steel *	316 St. St.	316 LSS	A __	•
	Carbon Steel *	316 St. St.	Hastelloy C	B __	•
	316 St. St.	316 St. St.	316 LSS	E __	• •
	316 St. St.	316 St. St.	Hastelloy C	F __	• •
	Hastelloy C	Hastelloy C	Hastelloy C	J __	•
Fill Fluid	Silicone DC200			_ 1 _	• •
	CTFE			_ 2 _	• •
Process Head	1/4" NPT			_ _ A	•
Configuration	1/2" NPT with Adapter			_ _ G	t
	1/2" NPT			_ _ G	•

TABLE II

No Selection	00000	• •
--------------	-------	-----

* Carbon Steel heads are zinc-plated. Not recommended for water service due to hydrogen migration. Use Stainless Steel heads.

** Vent/Drains are Teflon coated for lubricity.

*** The standard reference head for the STG9XX is carbon steel (zinc-plated). See Table III for a stainless steel reference (HR) head option.

Note: End vent drain valve standard for STG9XX.

Model Selection Guide, continued

TABLE III - OPTIONS	Selection	Availability			
		44	74	7L	8L
None	00	•	•		
Viton Process Head Gaskets (teflon is standard)	VT	•			
Teflon Process Head Gaskets (viton is standard)	TF				
A286SS (NACE) Bolts and 302/304SS (NACE) Nuts for Heads	CR	•			
Analog Meter (0-100 Even 0-10 Square Root)	ME	•	•		
Smart Meter	SM	•	•		
Stainless Steel Customer Wired-On Tag	TG	•	•		
(4 lines, 28 characters per line, customer supplied information)					
Stainless Steel Customer Wired-On Tag (blank)	TB	•	•		
Adapter Flange - 1/2" NPT St. Steel	S1	c			
Adapter Flange - 1/2" NPT Hastelloy-C	T1	c			
Modified DIN Process Heads - 316SS	DN	w			
Mounting Bracket - Carbon Steel	MB	•	•		
Mounting Bracket - ST. ST.	SB	•	•		b
Flat Mounting Bracket - Carbon Steel	FB	•	•		
316 ST.ST. Electronics Housing with M20 Conduit Connections	SH	m	m		
1/2" NPT to M20 316SS Conduit Adapter (BASEEFA EEx d IIC)	A1	n	n		b
1/2" NPT to 3/4" NPT 316 SS Conduit Adapter	A2	u	u		
Side Vent/Drain	SV	d			
Custom Calibration and I.D. in Memory	CC	•	•		
Transmitter Configuration	TC	•	•		
Write Protection	WP	•	•		
Local Zero	LZ	x	x		b
Local Zero and Span	ZS	s	s		
Lightning Protection	LP	•	•		
St. St. Reference Head (Carbon Steel standard)	HR	•	•		
Clean Transmitter for Oxygen or Chlorine Service with Certificate	OX	h	h		
Over-Pressure Leak Test with F3392 Certificate	TP	•	•		
Additional Warranty - 1 year	W1	•	•		
Additional Warranty - 2 years	W2	•	•		b
Additional Warranty - 3 years	W3	•	•		
Additional Warranty - 4 years	W4	•	•		
Blind DIN SS Flanges Mounted with NACE Bolts	B1	y			
Low Temperature - -50°C Ambient Limit	LT	z	•		
Calibration Test Report and Certificate of Conformance (F3399)	F1	•	•		b
Certificate of Conformance (F3391)	F3	•	•		
Certificate of Origin (F0195)	F5	•	•		
NACE Certificate (F0198)	F7	o	o		
HART® Protocol Compatible Electronics	HC	e	e		b
FOUNDATION Fieldbus Communications	FF	r	r		

Table III continued next page

Model Selection Guide, continued

TABLE III - OPTIONS (continued)			Selection	Availability	
Approval Body	Approval Type	Location or Classification		44 74	4L 7L 8L
No hazardous location approvals			9X	•	•
Factory Mutual	Explosion Proof	Class I, Div. 1, Groups A,B,C,D	1C	•	•
	Dust Ignition Proof	Class II, III Div. 1, Groups E,F,G			
	Non-Incendive	Class I, Div. 2, Groups A,B,C,D			
	Intrinsically Safe	Class I, II, III, Div. 1, Groups A,B,C,D,E,F,G			
CSA	Explosion Proof	Class I, Div. 1, Groups B,C,D	2J	•	•
	Dust Ignition Proof	Class II, III, Div. 1, Groups E,F,G			
	Intrinsically Safe	Class I, II, III, Div. 1, Groups A,B,C,D,E,F,G			
Zone 2 (Europe)	Self-Declared per 94/9/EC (ATEX4)	Ex II 3 GD T ⁽¹⁾ X (1) T4 at Tamb. 93°C, T5 at Tamb. 80°C, T6 at Tamb. 65°C	3N	•	•
SA (Australia)	Intrinsically Safe	Ex ia IIC T4	4H	a	a
	Non-Incendive	Ex n IIC T6 (T4 with SM option)			
	Flame Proof	Ex d IIC T6			
LCIE	Flame Proof/ CENELEC	EEx d IIC T6	3A	•	•
	Intrinsically Safe/ CENELEC	EEx ia IIC T5			
	Flame Proof/ CENELEC	EEx d IIC T6	3D	•	•
TABLE IV					
Factory Identification			XXXX	•	•

Model Selection Guide, continued

RESTRICTIONS

Restriction		Available Only With		Not Available With
Letter	Table	Selection	Table	Selection
a		Approval Body Pending		
b		Select only one option from this group		
c	I	-- G		
d			III	DN, B1
e	III	1C, 2J, 3D, 3N, 9X		
h	I	- 2 -		
m			III	ZS, 1C, 2J
n			III	1C, 2J
o	III	CR or B1		
r	III	1C, 2J, 3A, 3D, 3N, 4H, 9X		
s			III	FF, ME
t		Select adapter from Table III S1, T1		
u	III	1C, 2J		
v	I	E _ G, F _ G		
w	I	E _ A, F _ A	III	SV
x	III	FF, SM		
y	I	E _ A, F _ A	III	SV
	III	DN		
z			III	STG974

Note: See 13:ST-29 and User's Manual for part numbers.
 See 13:ST-OE-9 for OMS Order Entry Information including TC, manuals, certificates, drawings and SPINS.
 See 13:ST-OD-1 for tagging, ID, Transmitter Configuration (TC) and calibration including factory default values.
 To request a quotation for a non-published "special", fax RFQ to Marketing Applications.



ST 3000 Series 900 Smart Transmitter In-Line Gage Pressure (LGP)

Model Selection Guide with Price Data

Model Selection Guide
 34-ST-16-28 Issue 19

Honeywell Confidential & Proprietary

Instructions

- Select the desired Key Number. The arrow to the right marks the selection available.
 - Make one selection from each table, I and II, using the column below the proper arrow. Select as many Table III options as desired (if no options are desired, specify 00). A dot denotes unrestricted availability. A letter denotes restricted availability. Restrictions follow Table IV.
- Key Number I II III (Optional) IV
 [- - - - -] - [- - -] - [- - - - -] - [- , - - - -] + [XXXX]

List Price equals the sum of all selections made.

KEY NUMBER	Span	Selection	Availability	U.S.\$
Gage Pressure	0-20 to 0-500 psi/0-1.4 to 0-35 bar	STG94L	↓	933
	0-300 to 0-3000 psi/0-21 to 0-210 bar	STG97L	↓	1,035
	0-500 to 0-6000 psi/0-35 to 0-415 bar	STG98L	↓	1,035

TABLE I - METER BODY

	Wetted Process Heads	Vent/Drain Valves **	Barrier Diaphragms			U.S.\$
Material of Construction	316 St. St.	--	316 LSS	E _ _	•	0
	316 St. St.	--	Hastelloy C	F _ _	•	79
Fill Fluid	Silicone			_ 1 _	•	0
	CTFE			_ 2 _	•	52
Process Head Configuration	1/2" NPT (female)			_ _ G	•	0

TABLE II

No Selection	00000	•	0
--------------	-------	---	---

** Vent/Drains are Teflon coated for lubricity.

TABLE III - OPTIONS		Availability		U.S.\$
		STG9_L		
		Selection	4 7 8	
None	00	•		0
Custom Calibration and I.D. in Memory	CC	•		27
Transmitter Configuration	TC	•		16
Write Protection	WP	•		16
Stainless Steel Customer Wired-On Tag (4 lines, 28 characters per line, customer supplied information)	TG	•		6
Stainless Steel Customer Wired-On Tag (blank)	TB	•		6
Local Zero	LZ	x		27
Local Zero and Span	ZS	s	b	27
Mounting Bracket - Carbon Steel	MB	•		16
Mounting Bracket - ST. ST.	SB	•	b	67
Flat Mounting Bracket - Carbon Steel	FB	•		16
316 ST.ST. Electronics Housing with M20 Conduit Connections	SH	m		416
1/2" NPT to M20 316SS Conduit Adapter (BASEEFA EEx d IIC)	A1	n	b	42
1/2" NPT to 3/4" NPT 316 SS Conduit Adapter	A2	u		27
Lightning Protection	LP	•		57
Analog Meter (0-100 Even 0-10 Square Root)	ME	•	b	153
Smart Meter	SM	•		153
Additional Warranty - 1 year	W1	•		16
Additional Warranty - 2 years	W2	•	b	32
Additional Warranty - 3 years	W3	•		47
Additional Warranty - 4 years	W4	•		62
Clean Transmitter for Oxygen or Chlorine Service with Certificate	OX	h		114
Over-Pressure Leak Test with F3392 Certificate	TP	•		27
Low Temperature - -50°C Ambient Limit	LT	•		27
Calibration Test Report and Certificate of Conformance (F3399)	F1	•	b	16
Certificate of Conformance (F3391)	F3	•		6
Certificate of Origin (F0195)	F5	•		6
NACE Certificate (F0198)	F7	•		6
HART™ Protocol Compatible Electronics	HC	e	b	41
FOUNDATION Fieldbus Communications	FF	r		312

Table III continued next page

Availability
STG9 _ L

TABLE III - OPTIONS (continued)

Approval Body	Approval Type	Location or Classification	Selection	4 7 8	U.S.\$
No hazardous location approvals			9X	•	0
Factory Mutual	Explosion Proof	Class I, Div. 1, Groups A,B,C,D	1C	•	0
	Dust Ignition Proof	Class II, III Div. 1, Groups E,F,G			
	Non-Incendive	Class I, Div. 2, Groups A,B,C,D			
	Intrinsically Safe	Class I, II, III, Div. 1, Groups A,B,C,D,E,F,G			
CSA	Explosion Proof	Class I, Div. 1, Groups B,C,D	2J	•	0
	Dust Ignition Proof	Class II, III, Div. 1, Groups E,F,G			
	Intrinsically Safe	Class I, II, III, Div. 1, Groups A,B,C,D,E,F,G			
Zone 2 (Europe)	Self-Declared per 94/9/EC (ATEX4)	Ex II 3 GD T ⁽¹⁾ X (1) T4 at Tamb. 93°C, T5 at Tamb. 80°C, T6 at Tamb. 65°C	3N	•	0
SA (Australia)	Intrinsically Safe	Ex ia IIC T4	4H	a	0
	Non-Incendive	Ex n IIC T6 (T4 with SM option)			
	Flame Proof	Ex d IIC T6			
LCIE	Flame Proof/ CENELEC	EEx d IIC T6	3A	•	0
	Intrinsically Safe/ CENELEC	EEx ia IIC T5			
	Flame Proof/ CENELEC	EEx d IIC T6	3D	•	0

TABLE IV

Factory Identification	XXXX	•	0
------------------------	------	---	---

RESTRICTIONS

Restriction Letter	Table	Available Only With Selection	Table	Not Available With Selection
a		Approval Body Pending		
b		Select only one option from this group		
e	III	1C, 2J, 3D, 3N, 9X		
h	I	_ 2 _		
m			III	ZS, 1C, 2J
n			III	1C, 2J
r	III	1C, 2J, 3A, 3D, 3N, 4H, 9X	III	TC, ME
s			III	FF, ME
u	III	F1D3, C1C3, 1C, 2J		
x	III	FF, SM		

Note: See 13:ST-27 for Published Specials with pricing.
See 13:ST-29 and User's Manual for part numbers.
See 13:ST-OE-9 for OMS Order Entry Information including TC, manuals, certificates, drawings and SPINS.
See 13:ST-OD-1 for tagging, ID, Transmitter Configuration (TC) and calibration including factory default values.
To request a quotation for a non-published "special", fax RFQ to Marketing Applications.