

PRESSURE TRANSMITTER

DATA SHEET

FKG...4

The FCX-AII pressure transmitter accurately measures gauge pressure and transmits a proportional 4 to 20mA signal.

The transmitter utilizes a unique micromachined capacitance silicon sensor with state-of-the-art microprocessor technology to provide exceptional performance and functionality.

FEATURES

- 1. High accuracy $\pm 0.07\%$**
0.07% accuracy is a standard feature. Fuji's micro-capacitance silicon sensor assures this accuracy for all elevated or suppressed calibration ranges without additional adjustment.
- 2. Minimum environmental influence**
The "Advance Floating Cell" design which protects the pressure sensor against changes in temperature, and overpressure substantially reduces total measurement error in actual field applications.
- 3. Fuji/HART® bilingual communications protocol and FOUNDATION™ fieldbus and Profibus™ compatibility**
FCX-AII series transmitter offers bilingual communications to speak both Fuji proprietary protocol and HART®. Any HART® compatible devices can communicate with FCX-AII. Further, by upgrading electronics FOUNDATION™ fieldbus and Profibus™ are also available.
- 4. Application flexibility**
Various options that render the FCX-AII suitable for almost any process applications include:
 - Analog indicator at either the electronics side or terminal side
 - Full range of hazardous area approvals
 - Built-in RFI filter and lightning arrester
 - 5-digit LCD meter with engineering unit
 - Stainless steel electronics housing
- 5. Burnout current flexibility (Under Scale: 3.2 to 3.8mA, Over Scale: 20.8 to 21.6mA)**
Burnout signal level is adjustable using Model FXW Hand Held Communicator (HHC) to comply with NAMUR NE43.
- 6. Dry calibration without reference pressure**
Thanks to the best combination of unique construction of mechanical parts (Sensor unit) and high performance electronics circuit (Electronics unit), reliability of dry calibration without reference pressure is at equal level as wet calibration.



SPECIFICATIONS

Functional specifications

Service: Liquid, gas, or vapour
Span, range and overrange limit:

Type	Span limit [kPa] {bar}		Range limit [kPa] {bar}		Overrange limit [MPa] {bar}
	Min.	Max.	Lower limit	Upper limit	
FKG□01	1.3 {0.013}	130 {1.3}	-100 {-1}	130 {1.3}	1 {10}
FKG□02	5 {0.05}	500 {5}	-100 {-1}	500 {5}	1.5 {15}
FKG□03	30 {0.3}	3000 {30}	-100 {-1}	3000 {30}	9 {90}
FKG□04	100 {1}	10000 {100}	-100 {-1}	10000 {100}	15 {150}
FKG□05	500 {5}	50000 {500}	-100 {-1}	50000 {500}	75 {750}

Remark: To minimize environmental influence, span should be greater than 1/40 of the max. span in most applications.

- Lower range limit (vacuum limit) ;
Silicone fill sensor: See Fig. 1
Fluorinated fill sensor: 66kPa abs (500mmHg abs) at below 60°C
- Conversion factors to different units;
1 MPa=10³ kPa=10bar=10.19716kgf/cm²= 145.0377psi
1kPa=10mbar=101.9716mmH₂O =4.01463inH₂O

Output signal: 4 to 20mA DC with digital signal superimposed on the 4 to 20mA signal.

Power supply: Transmitter operates on 10.5V to 45V DC at transmitter terminals.

10.5V to 32V DC for the units with optional arrester.

Load limitations: see figure below

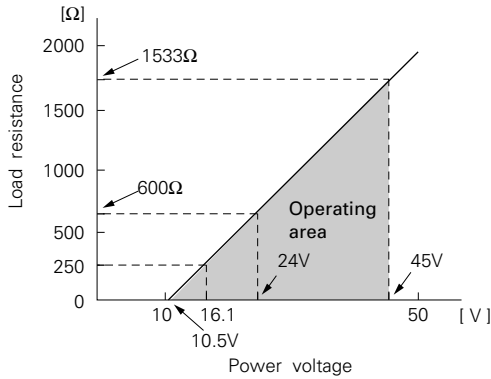

Note: For communication with HHC⁽¹⁾ (Model: FXW), min. of 250 Ω required.

Hazardous locations:

Authorities	Flameproof
ATEX	Ex II 2 GD EEx d IIC T6 IP66/67 T85°C Tamb = -40°C to +65°C EEx d IIC T5 IP66/67 T100°C Tamb = -40°C to +85°C
Factory Mutual	Class I Div.1 Groups B, C, D T6 Type 4X Class II III Div.1 Groups E, F, G T6 Type 4X Tamb max = +60°C
CSA	Class I Div.1 Groups C, D Class II Div.1 Groups E, F, G Class III Div.1 Note) "Seal Not Required" enclosure is allowed.
TIIS	Ex do IIB+H ₂ T4 Tamb max = +55°C Maximum process temp. = +120°C
IECEX Scheme /SAA	Ex d IIC T5 IP66/67 pending Tamb = -40°C to +85°C Ex d IIC T6 IP66/67 pending Tamb = -40°C to +65°C

Authorities	Intrinsic safety																					
ATEX	Ex II 1 GD EEx ia IIC T5 Tamb = -40°C to +40°C EEx ia IIC T4 Tamb = -40°C to +80°C Entity Parameters: Ui=28V, li=93.3mA, Pi=0.66W, Ci=27nF (Without Arrester), Ci=34.2nF (With Arrester), Li=1.134mH																					
Factory Mutual	Class I II III Div.1 Groups A, B, C, D, E, F, G T4 Entity Type 4X <table border="1"> <thead> <tr> <th colspan="2">Model code</th> <th>Tamb</th> </tr> <tr> <th>9th digit</th> <th>13th digit</th> <th></th> </tr> </thead> <tbody> <tr> <td>A,B,D</td> <td>Y,G,N,R</td> <td>-40°C to +85°C</td> </tr> <tr> <td>L,P,1,2</td> <td>Y,G,N,R</td> <td>-20°C to +80°C</td> </tr> <tr> <td>Q,S,4,5</td> <td>Y,G,N,R</td> <td>-20°C to +60°C</td> </tr> <tr> <td>E,F,H</td> <td>Y,G,N,R</td> <td>-40°C to +60°C</td> </tr> <tr> <td>-</td> <td>W,A,D</td> <td>-10°C to +60°C</td> </tr> </tbody> </table> Entity Parameters: Vmax=42.4V, Imax=113mA, Pi=1W, Ci=34.2nF, Li=1.134mH	Model code		Tamb	9th digit	13th digit		A,B,D	Y,G,N,R	-40°C to +85°C	L,P,1,2	Y,G,N,R	-20°C to +80°C	Q,S,4,5	Y,G,N,R	-20°C to +60°C	E,F,H	Y,G,N,R	-40°C to +60°C	-	W,A,D	-10°C to +60°C
Model code		Tamb																				
9th digit	13th digit																					
A,B,D	Y,G,N,R	-40°C to +85°C																				
L,P,1,2	Y,G,N,R	-20°C to +80°C																				
Q,S,4,5	Y,G,N,R	-20°C to +60°C																				
E,F,H	Y,G,N,R	-40°C to +60°C																				
-	W,A,D	-10°C to +60°C																				
CSA	Class I Div.1 Groups A, B, C, D Class II Div.1 Groups E, F, G Class III Div.1 Temp Code T4 Tamb max = +40°C Temp Code T3C Tamb max = +85°C Entity Parameters: Vmax=28V, Imax=93mA, Ci=27nF (Without Arrester), Ci=34.2nF (With Arrester), Li=1.4mH																					
TIIS	Ex ia IIC T4 Tamb max = +60°C Entity Parameters: Ui=28V, li=94.3mA, Pi=0.66W, Ci=32.6nF, Li=1.134mH																					
IECEX Scheme /SAA	Ex ia IIC T4 IP66/67 Tamb = -40°C to +70°C Ex ia IIC T5 IP66/67 Tamb = -40°C to +50°C Entity Parameters: Ui=28V, li=93.3mA, Pi=0.66W, Ci=0.033μF, Li=1.034mH																					

Authorities	Type n Nonincendive																				
ATEX	Ex II 3 GD EEx nL IIC T5 Tamb = -40°C to +40°C EEx nL IIC T4 Tamb = -40°C to +80°C Specific Parameters: Model without arrester: Ui=42.4V, Ii=113mA, Pi=1W, Ci=27nF, Li=1.134mH Model with arrester: Ui=32V, Ii=113mA, Pi=1W, Ci=34.2nF, Li=1.134mH EEx nAL IIC T5 Tamb = -40°C to +40°C EEx nAL IIC T4 Tamb = -40°C to +80°C Specific Parameters: Model without arrester: Umax=42.4V, Imax=113mA, Pmax=1W Model with arrester: Umax=32V, Imax=113mA, Pmax=1W																				
Factory Mutual	Class I II III Div.2 Groups A, B, C, D, F, G T4 Entity Type 4X <table border="1"> <thead> <tr> <th colspan="2">Model code</th> <th rowspan="2">Tamb</th> </tr> <tr> <th>9th digit</th> <th>13th digit</th> </tr> </thead> <tbody> <tr> <td>A,B,D</td> <td>Y,G,N,R</td> <td>-40°C to +85°C</td> </tr> <tr> <td>L,P,1,2</td> <td>Y,G,N,R</td> <td>-20°C to +80°C</td> </tr> <tr> <td>Q,S,4,5</td> <td>Y,G,N,R</td> <td>-20°C to +60°C</td> </tr> <tr> <td>E,F,H</td> <td>Y,G,N,R</td> <td>-40°C to +60°C</td> </tr> <tr> <td>-</td> <td>W,A,D</td> <td>-10°C to +60°C</td> </tr> </tbody> </table>	Model code		Tamb	9th digit	13th digit	A,B,D	Y,G,N,R	-40°C to +85°C	L,P,1,2	Y,G,N,R	-20°C to +80°C	Q,S,4,5	Y,G,N,R	-20°C to +60°C	E,F,H	Y,G,N,R	-40°C to +60°C	-	W,A,D	-10°C to +60°C
Model code		Tamb																			
9th digit	13th digit																				
A,B,D	Y,G,N,R	-40°C to +85°C																			
L,P,1,2	Y,G,N,R	-20°C to +80°C																			
Q,S,4,5	Y,G,N,R	-20°C to +60°C																			
E,F,H	Y,G,N,R	-40°C to +60°C																			
-	W,A,D	-10°C to +60°C																			
CSA	Class I Div.2 Groups A, B, C, D Class II Div.2 Groups E, F, G Class III Div.2 Temp Code T4 Tamb max = +40°C Temp Code T3C Tamb max = +85°C Entity Parameters: Vmax=28V, Ci=27nF (Without Arrester), Ci=34.2nF (With Arrester), Li=1.4mH																				
TIIS	-																				
IECEX Scheme /SAA	-																				

Zero/span adjustment:

Zero and span are adjustable from the HHC⁽¹⁾. Zero and span are also adjustable externally from the adjustment screw (span adjustment is not available with 9th digit code "L, P, Q, S").

Damping:

Adjustable from HHC or local adjustment unit with LCD display. The time constant is adjustable between 0.12 to 32 seconds.

Zero elevation/suppression:

Zero can be elevated or suppressed within the specified range limit of each sensor model.

Normal/reverse action:

Selectable from HHC⁽¹⁾.

Indication:

Analog indicator or 5-digit LCD meter, as specified.

Burnout direction: Selectable from HHC⁽¹⁾

If self-diagnostic detect transmitter failure, the analog signal will be driven to either "Output Hold", "Output Overscale" or "Output Underscale" modes.

"Output Hold":

Output signal is hold as the value just before failure happens.

"Output Overscale":

Adjustable within the range 20.8mA to 21.6mA from HHC⁽¹⁾

"Output Underscale":

Adjustable within the range 3.2mA to 3.8mA from HHC

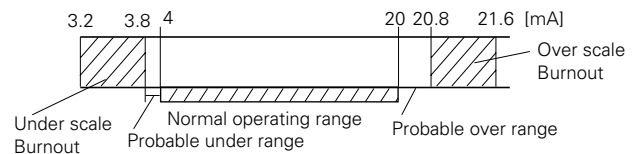

Loop-check output:

Transmitter can be configured to provide constant signal 3.8mA through 21.6mA by HHC.

Temperature limit:

Ambient: -40 to +85°C
 (-20 to +80°C for LCD indicator)
 (-40 to +60°C for arrester option)
 (-10 to +60°C for fluorinated oil fill transmitter)
 For explosionproof units (flameproof or intrinsic safety), ambient temperature must be within the limits specified by each standard.

Process: -40 to +100°C for silicone fill sensor
 -20 to +80°C for fluorinated oil fill sensor

Storage: -40 to +90°C

Humidity limit:

0 to 100% RH

Communication:

With HHC⁽¹⁾ (Model FXW, consult Data Sheet No. EDS8-47), following information can be remotely displayed or reconfigured.

Note: HHC's version must be more than 6.0 (or FXW □□□□1-□3), for FCX-A II.

Items	Display	Set
Tag No.	✓	✓
Model No.	✓	✓
Serial No.	✓	—
Engineering unit	✓	✓
Range limit	✓	—
Measuring range	✓	✓
Damping	✓	✓
Output mode	✓	—
Burnout direction	✓	✓
Calibration	✓	✓
Output adjust	—	✓
Data	✓	—
Self diagnoses	✓	—
Printer	—	—
External switch lock	✓	✓
Transmitter display	✓	✓
Linearize	✓	✓
Rerange	✓	✓

EMC Conformity: EN61326 CE

(Note) (1) HHC: Hand Held Communicator

Performance specifications

Reference conditions, silicone oil fill, 316SS isolating diaphragms, 4 to 20mA analog output in linear mode.

Accuracy rating: (including linearity, hysteresis, and repeatability)

Max span below 10000kPa model:

For spans greater than 1/10 of URL: $\pm 0.07\%$ of span
 For spans below 1/10 of URL:

$$\pm \left(0.02 + 0.05 \frac{0.1 \times \text{URL}}{\text{Span}} \right) \% \text{ of span}$$

Max span 50000kPa model:

For spans greater than 1/10 of URL: $\pm 0.1\%$ of span
 For spans below 1/10 of URL:

$$\pm \left(0.05 + 0.05 \frac{0.1 \times \text{URL}}{\text{Span}} \right) \% \text{ of span}$$

Stability: $\pm 0.1\%$ of upper range limit (URL) for 3 years.

Temperature effect:

Effects per 28°C change between the limits of -40°C and +85°C

Zero shift: $\pm \left(0.075 + 0.0125 \frac{\text{URL}}{\text{span}} \right) \%$

Total effect: $\pm \left(0.095 + 0.0125 \frac{\text{URL}}{\text{span}} \right) \%$

Overrange effect: Zero shift; 0.2% of URL for any overrange to maximum limit

Supply voltage effect:

Less than 0.005% of calibrated span per 1V

RFI effect: Less than 0.2% of URL for the frequencies of 20 to 1000MHz and field strength 30 V/m when electronics covers on. (Classification: 2-abc: 0.2% span per SAMA PMC 33.1)

Update period: 120 msec *)

Step response: Time constant: 0.2s *)

Dead time: approximately 0.2s *) (without electrical damping)

*) Faster response is available as option (maximum update rate: 25 times per second).

Mounting position effect:

Zero shift, less than 0.1kPa {1m bar} for a 10° tilt in any plane.

No effect on span. This error can be corrected by adjusting Zero.

Dielectric strength:

500V AC, 50/60Hz 1 min., between circuit and earth.

Insulation resistance:

More than 100MΩ at 500V DC.

Turn-on time: 4 sec.

Internal resistance for external field indicator:

12Ω or less

Physical specifications

Electrical connections:

G1/2, 1/2-14 NPT, Pg13.5, or M20 x 1.5 conduit, as specified.

1-port (standard) or 2-port with each conduit, as specified.

Process connections:

1/4-18 NPT or Rc1/4 on 54mm centers, as specified.

Meet DIN 19213

Process-wetted parts material:

Material code (7th digit in Code symbols)	Process cover	Diaphragm	Wetted sensor body	Vent/drain
V	316 stainless steel(*)	316L stainless steel	316 stainless steel	316/316L stainless steel
J	316 stainless steel(*)	316L stainless steel +Au coating	316 stainless steel	316/316L stainless steel
H	316 stainless steel(*)	Hastelloy-C	Hastelloy-C lining	316/316L stainless steel
M	316 stainless steel(*)	Monel	Monel lining	316/316L stainless steel
T	316 stainless steel(*)	Tantalum	Tantalum lining	316/316L stainless steel
B	Hastelloy-C lining	Hastelloy-C	Hastelloy-C lining	Hastelloy-C
L	Monel lining	Monel	Monel lining	Monel
U	Tantalum lining	Tantalum	Tantalum lining	Hastelloy-C

Note: (*) SCS14A per JIS G 5121 (equivalent CF8M per ASTM A351/A351M)

Remarks: Sensor O-rings: Viton O-ring and teflon gasket selectable. Availability of above material design depends on ranges. Refer to "Code symbols".

Non-wetted parts material:

Electronics housing: Low copper die-cast aluminum alloy finished with epoxy/polyurethane double coating (standard), or 316 stainless steel (SCS14A per JIS G5121), as specified.

Bolts and nuts: Cr-Mo alloy (standard), or 304 stainless steel (630 stainless steel for 50MPa unit).

Fill fluid: Silicone oil (standard) or fluorinated oil

Mounting bracket: 304 stainless steel

Environmental protection:

IEC IP67 and NEMA 6/6P

Mounting:

On 60.5mm (JIS 50A) pipe using mounting bracket, direct wall mounting, or direct process mounting.

Mass {weight}:

Transmitter approximately 3.4kg without options.

Add; 0.5kg for mounting bracket

0.8kg for indicator option

4.5kg for stainless steel housing option

Optional features

- Indicator:** A plug-in analog indicator (2.5% accuracy) can be housed in the electronics compartment or in the terminal box of the housing.
An optional 5-digit LCD meter with engineering unit is also available.
- Local adjustment unit with LCD display:** An optional 5-digit LCD meter with Zero/ Span adjustment function, loop-check function and damping adjustment function, is available.
- Arrester:** A built-in arrester protects the electronics from lightning surges.
Lightning surge immunity:
4kV (1.2 × 50μs)
- Oxygen service:** Special cleaning procedures are followed throughout the process to maintain all process wetted parts oil-free.
The fill fluid is fluorinated oil.
- Chlorine service:** The fill fluid is fluorinated oil.
- Degreasing:** Process-wetted parts are cleaned, but the fill fluid is standard silicone oil. Not for use on oxygen or chlorine measurement.
- NACE specification:** Metallic materials for all pressure boundary parts comply with NACE MR-01-75. ASTM B7M or L7M bolts and 2HM nuts (Class II) are available.
- Vacuum service:** Special silicone oil and filling procedure are applied.
See Fig. 1.
- Optional tag plate:** An extra stainless steel tag with customer tag data is wired to the transmitter.
- Coating of cell:** Cell's surface is finished with epoxy/polyurethane double coating. Specify if environment is extremely corrosive.

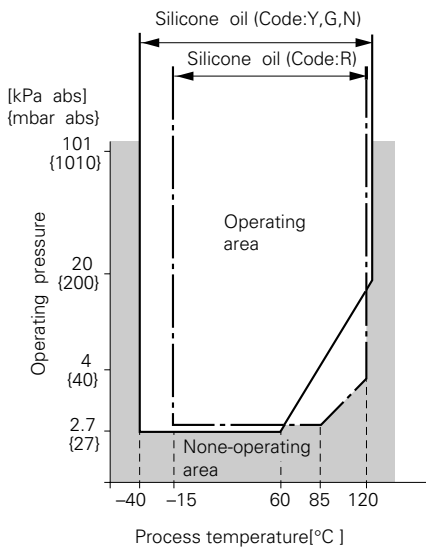

Fig. 1 Relation between process temperature and operating pressure

ACCESSORIES

- Oval flanges:** (Model FFP, refer to Data Sheet No. EDS6-10)
Converts process connection to 1/2-14 NPT or to Rc1/2; in carbon steel or in 316 stainless steel.
- Hand-held communicator:** (Model FXW, refer to Data Sheet No. EDS8-47)
- Z/S board:** Parts No.=ZZPFCX4-A070
When Z/S board is mounted on the FCX-AII amplifier unit, external adjustment screw will be available for zero and span adjustment.

The product conforms to the requirements of the Electromagnetic compatibility Directive 94/9/EC as detailed within the technical construction file number TN513035. The applicable standards used to demonstrate compliance are :

EMI (Emission) EN61326 : 1997
Class A (standard for Industrial Location)

Frequency range MHz	Limits	Reference standard
30 to 230	40dB (μV/m) quasi peak, measured at 10m distance	CISPR16-1 and CISPR16-2
230 to 1000	47dB (μV/m) quasi peak, measured at 10m distance	

EMI (Immunity) EN61326: 1997
Annex A (standard for Industrial Location)

Phenomenon	Test value	Basic standard	Performance criteria
Electrostatic discharge	4kV (Contact) 8kV (Air)	EN61000-4-2	B
Electromagnetic field	80 to 1000MHz 10V/m 80%AM (1kHz)	EN61000-4-3	A
Rated power frequency magnetic field	30A/m 50Hz	EN61000-4-8	A
Burst	2kV 5kHz	EN61000-4-4	B
Surge	1.2μs/50μs 1kV (Line to line) 2kV (Line to ground)	EN61000-4-5	B
Conducted RF	0.15 to 80MHz 3V 80%AM (1kHz)	EN61000-4-6	A

Note) Definition of performance criteria

A: During testing, normal performance within the specification limits.

B: During testing, temporary degradation, or loss of function or performance which is self-recovering.

CODE SYMBOLS

Digit	Description				Note	1	2	3	4	5	6	7	8	9	10	11	12	13	14	15	21	← Digit No. of code						
						F	K	G	0				4															
4	<Connections>																											
	Process connection	Oval flange screw	Conduit connection																									
	Rc1/4	7/16-20UNF	G1/2	(×1)	Combination with 12th digit code "C, E, P, Q" are not available.																							
	1/4-18NPT	7/16-20UNF	1/2-14NPT	(×1)																								
	1/4-18NPT	M10 (or M12)(*1)	Pg13.5	(×1)																								
	1/4-18NPT	M10 (or M12)(*1)	M20×1.5	(×1)																								
	1/4-18NPT	7/16-20UNF	Pg13.5	(×1)																								
	Rc1/4	7/16-20UNF	G1/2	(×2)																								
	1/4-18NPT	7/16-20UNF	1/2-14NPT	(×2)																								
	1/4-18NPT	M10 (or M12)(*1)	Pg13.5	(×2)	Note 1																							
1/4-18NPT	M10 (or M12)(*1)	M20×1.5	(×2)	Note 1																								
1/4-18NPT	7/16-20UNF	Pg13.5	(×2)	Note 1																								
6, 7																												
	Span limit [kPa]{bar}{*2}	Process cover	Diaphragm	Wetted cell body	Note 2																							
	1.3...130 {0.013...1.3}	316 stainless steel	316L stainless steel	316 stainless steel	316 stainless steel																			1V				
		316 stainless steel	316L stainless steel	316 stainless steel	316 stainless steel																			1J				
				+Au coating																								
		316 stainless steel	Hast. C		Hast. C lining																				1H			
		316 stainless steel	Monel		Monel lining																				1M			
		316 stainless steel	Tantalum		Tantalum lining																				1T			
		Hast. C lining	Hast. C		Hast. C lining																				1B			
		Monel lining	Monel		Monel lining																					1L		
		Tantalum lining	Tantalum		Tantalum lining																					1U		
		5...500 {0.05...5}	316 stainless steel	316L stainless steel	316 stainless steel	316 stainless steel																				2V		
	316 stainless steel		316L stainless steel	316 stainless steel	316 stainless steel																				2J			
				+Au coating																								
	316 stainless steel		Hast. C		Hast. C lining																					2H		
	316 stainless steel		Monel		Monel lining																					2M		
	316 stainless steel		Tantalum		Tantalum lining																					2T		
	Hast. C lining		Hast. C		Hast. C lining																					2B		
	Monel lining		Monel		Monel lining																						2L	
	Tantalum lining		Tantalum		Tantalum lining																						2U	
	30...3000 {0.3...30}		316 stainless steel	316L stainless steel	316 stainless steel	316 stainless steel																					3V	
		316 stainless steel	316L stainless steel	316 stainless steel	316 stainless steel																					3J		
				+Au coating																								
		316 stainless steel	Hast. C		Hast. C lining																					3H		
		316 stainless steel	Monel		Monel lining																					3M		
		316 stainless steel	Tantalum		Tantalum lining																					3T		
		Hast. C lining	Hast. C		Hast. C lining																					3B		
		Monel lining	Monel		Monel lining																						3L	
Tantalum lining		Tantalum		Tantalum lining																						3U		
100...10000 {1...100}		316 stainless steel	316L stainless steel	316 stainless steel	316 stainless steel																					4V		
	316 stainless steel	316L stainless steel	316 stainless steel	316 stainless steel																					4J			
			+Au coating																									
	316 stainless steel	Hast. C		Hast. C lining																					4H			
	316 stainless steel	Monel		Monel lining																					4M			
	316 stainless steel	Tantalum		Tantalum lining																					4T			
	Hast. C lining	Hast. C		Hast. C lining																					4B			
	Monel lining	Monel		Monel lining																						4L		
	Tantalum lining	Tantalum		Tantalum lining																						4U		
	500...50000 {5...500}	316 stainless steel	316L stainless steel	316 stainless steel	316 stainless steel																					5V		
316 stainless steel		316L stainless steel	316 stainless steel	316 stainless steel																					5J			
			+Au coating																									
Indicator				Arrester																								
None				None	Z/S board attached.																				A			
Analog, 0 to 100% linear scale				None																						B		
Analog, custom scale				None																							D	
None				Yes																						E		
Analog, 0 to 100% linear scale				Yes																							F	
Analog, custom scale				Yes																							H	
Digital, 0 to 100%			None																						L			
Digital, custom scale			None																							P		
Digital, 0 to 100%			Yes																							Q		
Digital, custom scale			Yes																							S		
Digital, 0 to 100%			None																								1	
(Local adjustment unit with LCD display)			None																								2	
Digital, custom scale			None																								4	
(Local adjustment unit with LCD display)			None																									5
Digital, 0 to 100%			Yes																									
(Local adjustment unit with LCD display)			Yes																									
Digital, custom scale			Yes																									
(Local adjustment unit with LCD display)			Yes																									

Note 1 : (*1) For 50MPa {500bar} units, M12 is provided rather than M10.
 Note 2 : (*2) 100: 1 turn down is possible, but should be used at the span greater than 1/40 of the maximum span for better performance.

Digit	Description	Note	1	2	3	4	5	6	7	8	9	10	11	12	13	14	15	21	← Digit No. of code				
10	<Approvals for hazardous locations> None (for ordinary locations) TIIS, Flameproof (Conduit seal) (Available for 4th digit code "A", "S") TIIS, Flameproof (Cable gland seal) (Available for 4th digit code "A", "S") FM, Flameproof (or explosionproof) (Available for 4th digit code "B", "T") CSA, Flameproof (or explosionproof) (Available for 4th digit code "B", "T") ATEX, Flameproof IECEx Scheme/SAA, Flameproof (Approval pending) TIIS, Intrinsic safety FM, Intrinsic safety and Nonincendive CSA, Intrinsic safety and Nonincendive ATEX, Intrinsic safety ATEX, Type n IECEx Scheme/SAA, Intrinsic safety FM, Combined of Flameproof and Intrinsic safety		F	K	G	0	4																
11	<Vent/ drain and mounting bracket> Vent/drain Mounting bracket Standard None } Specify "A", or "C" for the 7th Standard Yes, stainless steel } digit code "B", "L", or "U" Side None Side Yes, stainless steel												A	C	D	F							
12	<Options> Extra SS tag plate Stainless steel elec. housing Coating of cell None None None Yes None None None Yes None Yes Yes None None None Yes Yes None Yes None Yes Yes Yes Yes Yes	Note3												Y	B	C	E	M	N	P	Q		
13	<Special applications and fill fluid> Treatment Fill fluid Standard Silicone oil Standard Fluorinated oil Degreasing Silicone oil Oxygen service Fluorinated oil (7th digit code "V", "J" only) Chlorine service Fluorinated oil (7th digit code "H", "T", "B", "U") NACE specification Silicone oil (Not available for 6th digit code "5", 7th digit code "T", "U", 15th digit code "A", "B") Vacuum service Silicone oil for vacuum use														Y	W	G	A	D	N	R		
14	<Sensor O-ring / Gasket> Viton (O-ring) Teflon (gasket)																	A	B				
15	<Bolt/nut> Cr-Mo alloy hexagon socket head cap screw/carbon steel nut Cr-Mo alloy hexagon bolt/nut NACE bolt/nut (ASTM A193 B7M/A194 2HM) NACE bolt/nut (ASTM A320 L7M/A194 2HM) } Not available for 6th digit 304 stainless steel bolt/304 stainless steel nut } code "5" 630 stainless steel bolt/304 stainless steel nut } Available for 6th digit code "5"																	A	B	C	D	E	F
21	<Other options> (*4) Instruction manual unattached	Note4																					L

Note 3 : (*3) Customer tag number can be engraved on standard stainless steel name plate. If extra tag plate is required, select "Yes".

Note 4 : (*4) If other option is not necessary, 21st digit code is blank. In case of 21st digit code is blank, instruction manual attached.

ORDERING INFORMATION

When ordering this instrument, specify.

1. CODE SYMBOLS
2. Measuring range
3. Output orientation (burnout direction) when abnormality is occurred in the transmitter.
Hold/Overscale (21.6mA)/Overscale (3.2mA)
Unless otherwise specified, output hold function is supplied.
4. Indication method (indicated value and unit) in case of the actual scale (code D,H,P,S on 9th digit).
5. Tag No.(up to 26 alphanumerical characters), if required.

< 7th digit code : B, L, U >

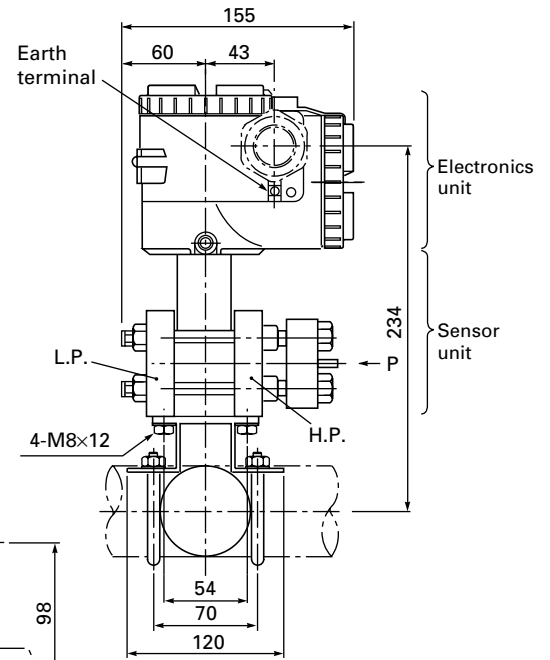
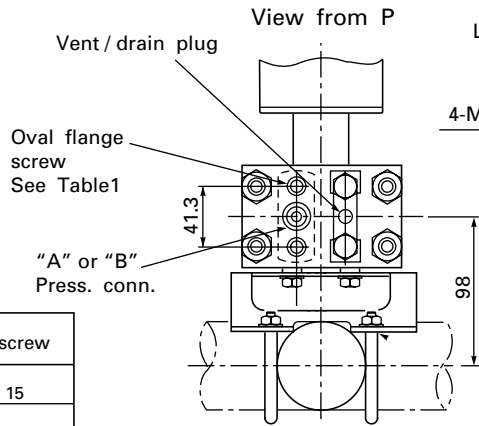
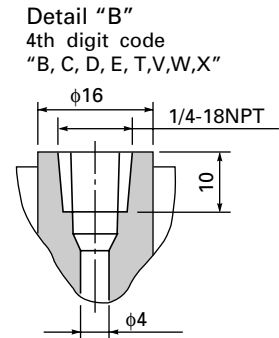
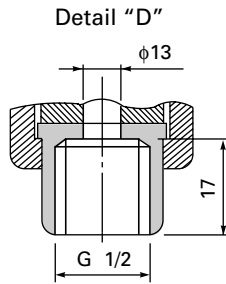
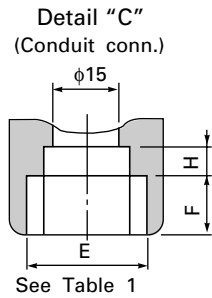
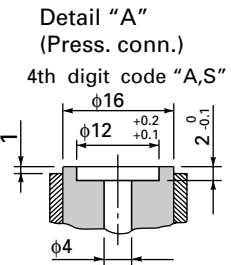
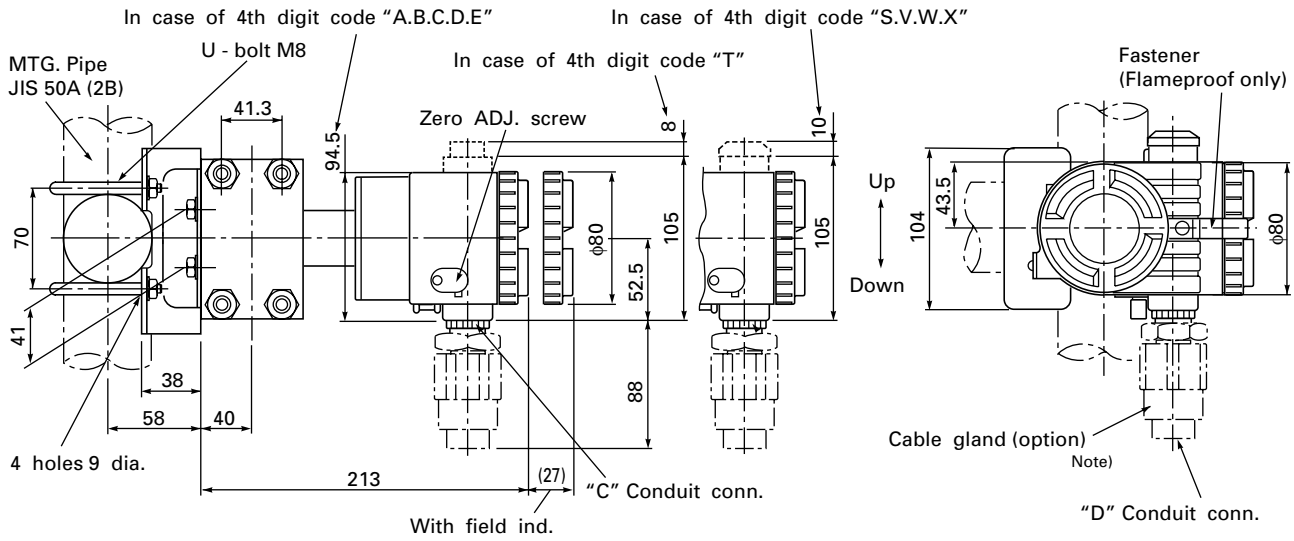

4th digit of the code symbols	Conduit conn.			Oval flange screw
	E	F	H	
A, S	G1/2	17	8	7/16-20UNF Screw depth 15
B, T	1/2-14NPT	16	5	7/16-20UNF Screw depth 15
C, V	Pg13.5	8	4.5	M10 Screw depth 15
D, W	M20x1.5	16	5	M10 Screw depth 15
E, X	Pg13.5	8	4.5	7/16-20UNF Screw depth 15

Table 1

Note 1) Cable gland is supplied in case of flameproof packing type. $\phi 11$ cable is suitable.

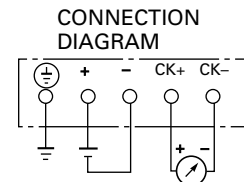

⚠ Caution on Safety

*Before using this product, be sure to read its instruction manual in advance.

Fuji Electric Systems Co., Ltd.

Head Office

Gate City Ohsaki, East Tower, 11-2, Osaki 1-chome,
Shinagawa-ku, Tokyo 141-0032, Japan

<http://www.fesys.co.jp/eng>

Instrumentation Div.

International Sales Dept.

No.1, Fuji-machi, Hino-city, Tokyo, 191-8502 Japan

Phone: 81-42-585-6201, 6202 Fax: 81-42-585-6187

<http://www.fic-net.jp/eng>

Information in this catalog is subject to change without notice.

Printed in Japan