

BENEFITS

The NGC (Natural Gas Chromatograph) performs on-site gas analysis and heating value computation where current chromatograph technology has been either impractical or unaffordable. This truly "transmitter-like" GC takes up no more room on the pipeline than most multi-variable transmitters. The fast analysis cycle and automatic setup features make installation and maintenance unusually easy. The state-of-the-art built-in 32 bit digital controller, the dual electronic carrier pressure regulators, oven-mounted sensors, and other low-noise electronics provide unparalleled sensitivity and months between calibrations. This revolutionary new GC is the third generation of Totalflow's highly integrated manifold technology that started with the Model 8000.



- New design, more compact, more reliable, more precise
- Custody transfer/metrology quality GC for heating value and composition
- Lower cost to buy, install and operate

STANDARD FEATURES

- Modular design includes:
 - ◇ Modular software – application based plug in software modules
 - ◇ Manifold module (internal tubing now replaced by manifold)
 - ◇ Analysis section contains stream selection solenoids, pressure regulation, 32 bit digital detector electronics and a dual-train chromatograph in a single, replaceable module
 - ◇ 32 bit digital, low-power controlling electronics, using Windows CE® (internal to GC unit)
- Microsoft® Windows® 2000 or XP based man-machine interface software (PCCU 32)
- Lithium battery-backed RAM
- Two remote serial digital communications ports; one local port
- Comprehensive diagnostics and wizards avail-

able to users

- Two-level security for user access control
- Audit-quality historical data; date and time stamped
- Auto-start cycle automatically:
 - ◇ Stabilizes oven temperature
 - ◇ Confirms modules' functions
 - ◇ Sets valve operation times
 - ◇ Locates natural gas components
 - ◇ Sets carrier gas pressures
 - ◇ Gates natural gas components
 - ◇ Validates/calibrates
 - ◇ Returns to pipeline streams
- Operational alarms available with each analysis cycle.
- Detectors - constant temperature, glass encapsulated thermister beads for rugged service and long life. Will not burn out on loss of carrier.
- Dual 10 port valves have no moving metal parts.
- Low utility usage - low-power, low-carrier, no instrument air required
- On demand or scheduled automatic calibration and diagnostics

STANDARD OPTIONS

- Sample Conditioning System
- On board digital 1/4 VGA display with multiple screen access
- USB (Host and Client) and Ethernet ports
- Calculation packages (eg, V.O.S.)
- SD memory cards
- Feed-Through heater
- C₇₊, C₉₊ analysis (future)

DESCRIPTION

A natural gas sample is extracted from a flowing pipeline, transported to the analyzer, processed for particle removal and phase integrity, injected onto the chromatographic columns where component separation and peak detection occurs.

The NGC 8206 analyzes each sample utilizing established chromatographic techniques. The resulting information consists of mole percent values for the following:

“Air” (Contains N₂, CO and O₂)
 C1 CO₂ C₂ C₃ IC₄ NC₄
 NeoC₅ IC₅ NC₅ C₆+

Using process chromatographic techniques, the columns are back flushed so that the NGC 8206 measures a C₆+ peak. Users may input the results of a comprehensive lab analysis that reflects the split or ratio of C₆ through C₁₀ components. This ratio can be used in subsequent analysis and energy calculations. Calculated values include:

- Gas compressibility per AGA 8
- Real Relative Density (Specific Gravity)
- Btu/CV Value
- GPM (gallons of liquid per thousand cubic feet)
- Wobbe Index
- Methane Number
- Optional calculations can include: AGA 10 speed of sound, (Hydrocarbon Dew Point, Vapor Pressure: to be developed)

The portioned sample is then vented with the carrier gas and results are stored in memory and communicated to other devices as needed. All of these values as well as composition are available on various modbus communication protocols.

INSTALLATION

The NGC 8206 is a weatherproof device designed for installation “on the pipe” near to the sampling point. This means it is acceptable to mount outside - in a temperature range of 0°F to 131°F (-18°C to 55°C), onto a pipeline with 2" to 12" pipe sizes or with an optional pole mount configuration. A cold weather enclosure is also available if ambient conditions are below either the sampled gas dew point or the operational specifications of the unit.

SAMPLE SYSTEM

The integral stream selector for the NGC 8206 allows sampling up to four (4) different natural gas streams. Up to two of these sample streams can be designated as the “calibration/validation sample”. Optional sample conditioning modules are available to address natural gas streams that need additional filtering and “speed loops” to reduce sample transport lag times.

SAMPLE PROBE

Totalflow recommends the use of a sample probe to obtain a representative sample of the flowing gas stream. Two brands of optional sample probes are available from Totalflow and are specifically designed to require no power and avoid sample probe regulator icing. An electrically heated probe is also available.

OPERATOR INTERFACE

Functional setup and operation of the NGC 8206 is accomplished by using a graphical user’s interface software package called PCCU 32 (supplied with each unit) operating on a laptop PC in a Microsoft® Windows® 2000 or XP environment. The “Windows®” utilities, combined with software designed specifically for the NGC 8206, provide a powerful tool for operations, diagnostics, and downstream data handling. The PC can be directly connected to the NGC 8206 via an RS-232, USB, or Ethernet connection, or indirectly by remote telemetry (phone modem, radio, cell phone, satellite, etc.). The user is prompted through push-buttons, drop-down boxes, wizards, and dialog boxes for setup, operations, data collection and monitoring.

In addition, the unit has an optional ¼ VGA interactive display screen allowing the user access to basic analysis data. The user can also accomplish most of the “operator” functions from the front panel display with out the use of a laptop PC. The “Run-Hold-Calibrate” functions can be done via a magnet interface through the explosion proof glass in the display.

MAINTENANCE

The NGC 8206 was designed from the ground up to be maintained by personnel with little or no prior knowledge of Gas Chromatography. Both hardware and software are designed to provide low maintenance through easily replaceable electro-mechanical modules such as:

- NGC Termination Panel
- NGC Analytical Module, an easily removable Chromatograph subassembly, containing; NGC Manifold, Stream Selector Solenoid Valves, GC valve assembly, Dual Electronic Carrier Pressure Regulator Valves, Chromatograph Pilot Valve, and the NGC Analytical Processor.
- NGC Feed-Through (with optional heater)

- Sample Conditioning Module (SCM)
- NGC Controller, (32 bit Processor)
- NGC ¼ VGA Display (Optional)

Other Maintenance Support Features:

- Intuitive Local Operator Interface (PCCU 32) running Microsoft® Windows® 2000 or XP
- Diagnostic software and wizards (future) for maintenance
- Diagnostic file output system for e-mail support (future)
- Digitized detector output (chromatogram) to PCCU 32
- Remote or local operation of PCCU 32
- Quick Start guide, Start up manual and Start up video (future)

HISTORICAL DATA

The NGC 8206 is designed to retain historical data. This data can be used for custody transfer needs, verify transmitter operation over time, and provide a limited data backup for communication link reliability.

The user is allowed to configure the period of the data retained by the NGC 8206 via the Operator Interface.

The default¹ memory configuration provides the most recent 480 analysis cycles containing:

- Normalized components
- Un-normalized components
- Ideal Btu/CV
- Real Btu (wet and dry) / CV (superior and inferior)
- Relative Density (Specific Gravity)
- Density
- GPM
- Wobbe index
- Alarms

Stream averages for the (default¹) 840 last hours, 35 last days and the most recent last month analyses.

Operational Parameters for the (default¹) last 480 cycles (Diagnostics Report):

- Selected peak times
- Selected peak areas
- Ideal Btu/CV
- Carrier regulator pressure
- Oven temperature

- Ambient temperature
- Sample pressure
- Detector noise values
- Detector balance values

Audit logs (default¹)

- Last 480 alarms
- Last 480 events

Data retained by the NGC 8206 can be collected via a remote communication link or by the laptop PC local operator interface PCCU 32.

SPECIFICATIONS

- Designed for Pipeline-Quality Natural Gas. 800 to 1500 Btu per standard cubic foot (29.8 to 55.9 megajoules/meter³) with less than 100 PPM H₂S
- Calculations Per: GPA 2172-96 (Z by AGA 8 or single virial summation) and 2145-03, ISO 6976-95; in the future: ASTM D 3588, GOST or ISO mass
- Carrier Gas: Helium (consumption rate <20 cc/minute during analysis cycle)
- Analysis Time: Approximately five (5) minutes; cycles may be scheduled by user
- Repeatability: ±0.125 Btu @ 1,000 Btu (±0.0125%) at ambient; and ±0.25 Btu @ 1,000 Btu (±0.025%) over temperature range of 0°F to 131°F (-18°C to 55°C)
- Environmental Temperature
 - ◊ Storage: -22°F to +140°F (-30°C to 60°C)
 - ◊ Normal Operation: 0°F to +131°F (-18°C to 56°C)
 - ◊ W/ Cold Weather Enclosure: -40°F to +131°F (-40°C to 56°C)
- Supply Voltage: 10.5 to 16 volts DC. Optional: 21 to 28 VDC
- Power Consumption (Nominal operation @ 0°F (-18°C)) = 7 Watts; (650 mA)
 - ◊ Start up: less than 3 amps (45 Watts @ 15 VDC)
- Meet or exceeds GPA 2261-99 for linearity
- Four stream capability. Manual calibration required with 4 sample streams.
- Single auto calibration stream and 3 sample streams, or 2 auto calibration streams and 2

(Default¹) The default memory configuration will provide for the data storage above. User may reallocate the memory that is available.

-
- sample streams.
 - Certifications:
 - ◇ NEC & CEC Class I, Div. 1, Groups B, C, and D, T6
 - ◇ CFR 47, Part 15
 - ◇ **CE**:
 - ATEX  II 2G : Ex d, IIB+H₂ T6; Class I, Zone 1
 - EMC - EMI/RFI:
 - EN 55022, EN 61000-6-1, EN 61000-4-2, 4-3, 4-4, 4-6, 4-8
 - CISPR 22-2004
 - IECEx Exd IIB + H₂ T6; Class I Zone 1
 - Miscellaneous Type Approvals:
 - ◇ Industry Canada
 - ◇ NMI (Pending)
 - ◇ BRML (Romania)
 - Communications supported:
 - ◇ Two serial digital ports, software selectable for RS232, RS485, or RS422
 - ◇ One Man-Machine Interface (RS232 or USB)
 - ◇ Optional USB hub (host and client) and Ethernet Ports
 - Protocols Supported:
 - ◇ Totalflow Remote / Local MMI
 - ◇ Totalflow / TCP
 - ◇ Modbus / TCP Server
 - ◇ Modbus / TCP Client
 - ◇ Modbus ASCII or RTU (Modicon, WordSwap, or Danalyzer)
 - ◇ DSFG (future)
 - Dimensions: 6.75" dia. × 16" long × 9.00" tall (17.1 cm × 40.6 cm × 22.9 cm)
 - Weight: Approximately 28 lb. (12.7 Kg)
 - Shipping Weight: 47 lb. (21.3 Kg).
 - Weatherproof Construction: NEMA/Type 4X/IP 56, aluminum alloy with white polyester powder coating.
 - Probes
 - ◇ Temperature compensating fixed
 - ◇ Temperature compensating retractable
 - ◇ Liquid rejection
 - ◇ Electrically heated, retractable
 - Regulators (carrier and calibration blend)
 - Start-up calibration/validation gas sample (±2% blend)
 - Carrier Gas: 99.995% pure helium (chromatographic grade)
 - SD memory card
 - Export crating
 - Tool kit
 - Welker liquid shut-offs
 - Various maintenance kits
 - Customer Factory Acceptance Test (FAT)

AVAILABLE ACCESSORIES

- 120/240 VAC to 12VDC GP and Exp power supplies
- Pole or pipeline mounting kits
- Cold weather enclosure (also available in pipe mount configuration)
- Cold weather thermal jacket (future)
- Modular Sample System Conditioner options for
 - ◇ Non-pipeline quality natural gas sample
 - ◇ Sample transport lag-time needs

Installation Dimensions

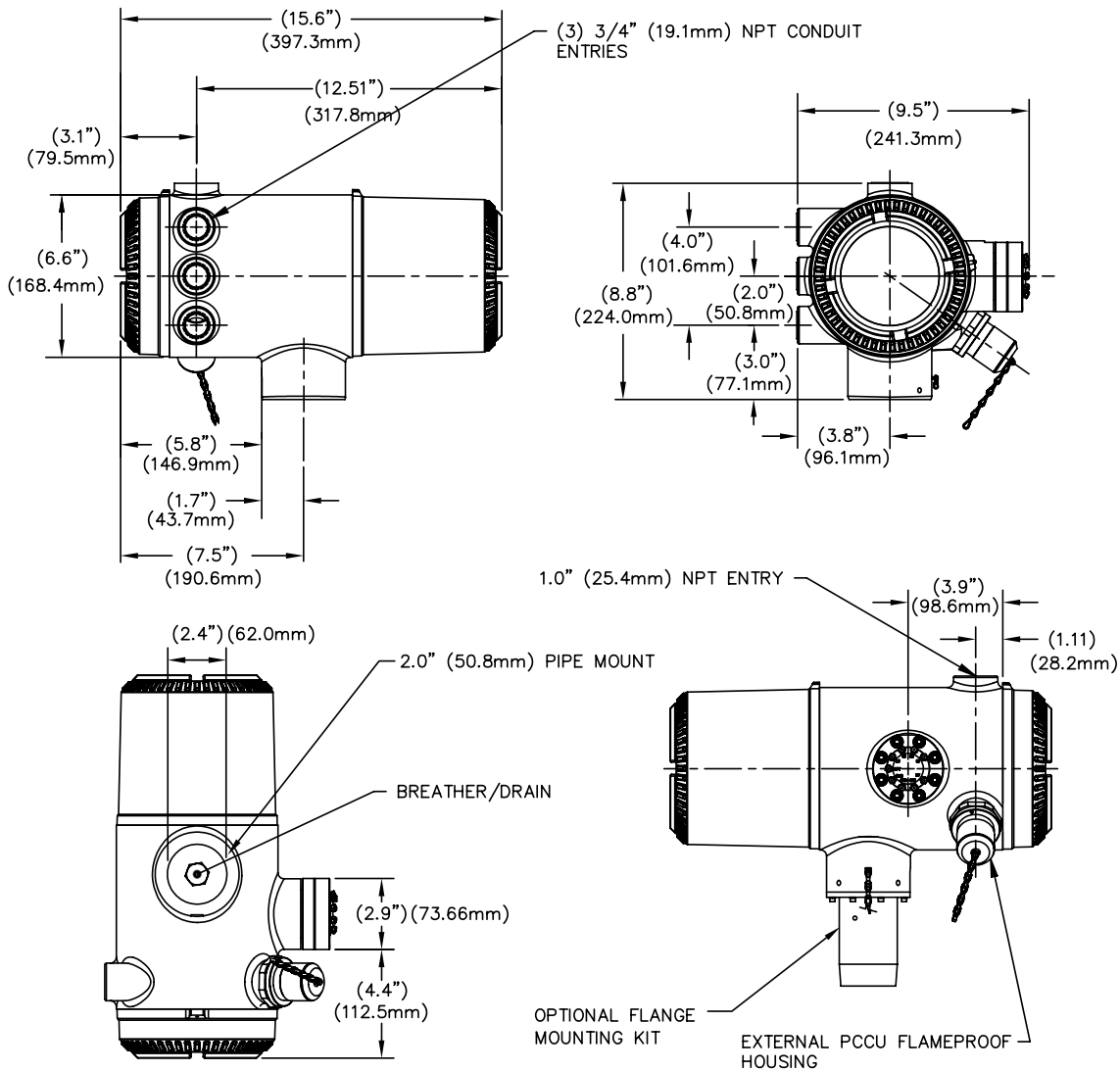

Power and Productivity
 for a Better World.™

www.abb.com/totalflow
www.abb.us
www.abb.com



ABB Inc.
Totalflow Products
 7051 Industrial Blvd.
 Bartlesville, OK 74006
 Tel: (918) 338-4888
 Fax: (918) 338-4699
 (800) 442-3097

ABB Inc.
Totalflow Products
 433 Northpark Central Dr., Ste. 100
 Houston, TX 77073
 Tel: (281) 869-5212
 Fax: (281) 869-5203
 (800) 442-3097

For more information,
 please contact your
 local ABB Totalflow
 representative or visit
 our website.