



H250 Technical Datasheet

Variable Area Flowmeter

- Complete family with different displays
- Local indication without the need for auxiliary power
- Measurement in all flow directions
- Rugged design for extreme operating conditions
- Flexible and can be adapted to meet customer-specific requirements
- Special food & pharmaceutical models



The standard solution in the process industry

The all-metal flowmeter H250 is used in the measurement of volume or mass flow of liquids, gases, and vapors.

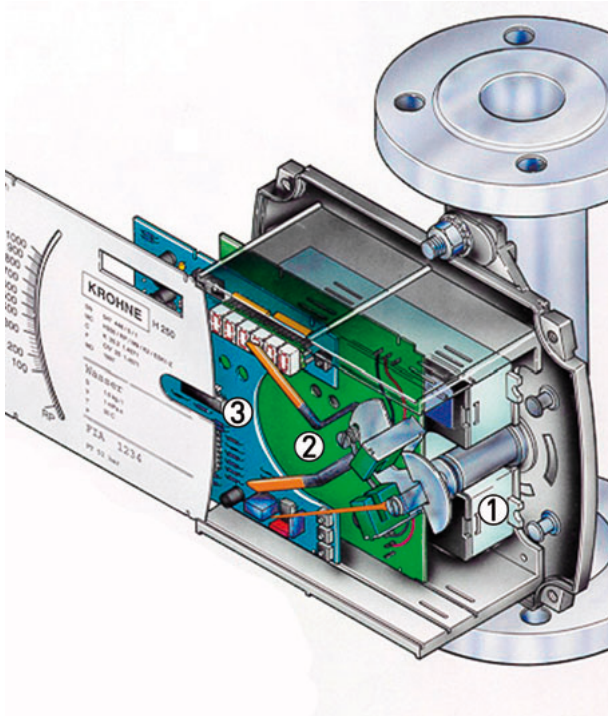

- ① ESK2A - ESK3PA
- ② Limit monitors
- ③ Counter ESK Z

Highlights

- Consistently used overall length concept
- Low loss of pressure for gas applications
- Measurement at operating pressures up to 3000 bar
- Measurement at extremely low and high process temperatures (-200°C to +300°C)
- Fast non-interruptive retrofitting of the modules
- The only EHEDG-certified variable area flow meter permitted for use with food & pharmaceuticals.
- Dead space-free, CIP and SIP capable
- SIL 2 certified

Industries

Can be used in all industrial sectors, for example:

- Chemical
- Petrochemical
- Pharmaceutical
- Mechanical engineering
- Food and Beverage
- Oil and Gas
- Iron, Steel and Metals
- Power plants
- Pulp and Paper
- Water and Wastewater

Applications

- Continuous gas and liquid measurement
- Measurement of non-conductive materials
- Industrial burner controlling
- Compressor monitoring
- Dry-run protection of pumps

The all-metal product family

Variable-area flowmeters of the type H250



For flow rates up to 120 m³/h (water) and 2800 m³/h (air)

① H250/RR/M9

- Local display without auxiliary power
- max. 2 limit monitors of the type NAMUR, NAMUR security-relevant, or 3-wire open collector
- 2-wire current output 4...20 mA, HART™ or Profibus communication
- 6-character flowmeter (non-Ex)

② H250/RR/M10

- Pressure-resistant casing Ex d
- 2 digitally adjustable limit monitors, 2-wire open collector or NAMUR type
- 2-wire current output 4...20 mA, HART™ communication
- Pulse output up to 10Hz (also for electromechanical counter)
- 12-character flowmeter with external back-spacing (batch operation)

③ H250/RR/M8E

- Slim housing allows high density installations
- 2-wire current output 4...20 mA, HART™ communication

④ H250/RR/M8M

- Slim housing allows high density installations
- Local display without auxiliary power
- 2 limit monitors, 2-wire NAMUR type or NAMUR security-relevant

Technical data

Application range	Flow measurement of liquids, gases and vapors
Function / measuring principle	Suspended solid particle measuring principle
Measuring accuracy H250 /RR /HC /F	± 1.6% acc. to directive VDI / VDE 3513, sheet 2
Measuring accuracy H250/C (ceramic/PTFE)	± 2.5% acc. to directive VDI / VDE 3513, sheet 2
Inlet run	≥ 5 x DN
Outlet run	≥ 3 x DN
Operating pressure PS	up to 3000 bar per directive 97/23/ EC, April 29, 1999
Test pressure PT	per pressure equipment directive 97/23/EC or AD 2000-HP30
Min. required operating pressure	Twice as great as pressure loss (see measuring ranges)
Suspended solid particle decrease during gas measurement recommended:	
DN15 / ½"	Operating pressure less than 0.3 bar
DN25 / 1"	Operating pressure less than 0.3 bar
DN50 / 2"	Operating pressure less than 0.2 bar
DN80 / 3"	Operating pressure less than 0.2 bar
DN100 / 4"	Operating pressure less than 0.2 bar

Nominal sizes, DIN

Nominal sizes as per EN 1092-1	Bolts Quantity x size	Tightening torques	
		SI [Nm]	Imp [lb-ft]
DN15 PN40	4 x M12	9.8	7.1
DN25 PN40	4 x M12	21	15
DN50 PN40	4 x M16	57	41
DN80 PN16	8 x M16	47	34
DN100 PN16	8 x M16	67	48

Nominal sizes, ASME

Normal sizes as per ASME B 16.5	Bolts Quantity x size	Tightening torques	
		SI [Nm]	Imp [lb-ft]
½" 150 lbs / 300 lbs	4 x ½"	5.2	3.8
1" 150 lbs / 300 lbs	4 x ½"	10	7.2
2" 150 lbs / 300 lbs	4 x 5/8"	41	30
3" 150 lbs / 300 lbs	4 x 5/8"	70	51
4" 150 lbs / 300 lbs	8 x 5/8"	50	36

Weights

Weights [kg]	H250		with heating		H250/C			Screw connection
	Nominal diameter	EN 1092-1	Flange connection	Ermeto 12 connection	EN 1092-1	ASME B 16.5 / 150 lbs	ASME B 16.5 / 300 lbs	DIN 11864-1
DN15 / ½"	3.5	5.55	5.7	3.5	3.2	3.5	2	
DN25 / 1"	5	7.45	7.6	5	5.2	6.8	3.5	
DN50 / 2"	8.2	11.15	11.3	10	10	11	5	
DN80 / 3"	12.2	14.75	14.9	13	13	15	7.6	
DN100 / 4"	14	17.35	17.5	15	16	17	10.3	

Process connections

	Standards	Connection dimensions	Pressure rating
Flange (H250/RR /HC /C)	EN-1092-1	DN15...DN100	PN16...PN100
	ASME B16.5	1/2"...4"	150 lbs...600 lbs
	JIS B 2238	LR15...LR100	10K...20K
Clamp connections (H250/RR /F)	DIN 32676	DN15...DN100	10 bar...16 bar
	ISO 2852	Size 25...139.7	10 bar...16 bar
Threaded connections (H250/RR /HC /F)	DIN 11851	DN15...DN100	25 bar...40 bar
	SMS 1146	1"...4"	6 bar
Inside thread welded (H250/RR /HC)	ISO 228	G1/2"...G2"	PN50
	ASME B1.20.1	1/2"...2" NPT	
Inside thread, screwed (H250/RR /HC) with insert and union nut	ISO 228	G1/2"...2"	PN40...PN50
	ASME B1.20.1	1/2"...2" NPT	
Aseptic threaded connection (H250/F)	DIN 11864 - 1	DN15...DN50	PN40
	-	DN80...DN100	PN16
Aseptic flange (H250/F)	DIN 11864 - 2	DN15...DN50	PN40
	-	DN80...DN100	PN16
Meters (H250/RR /HC) with heating:	EN 1092-1	DN15	PN40
Heating with flange connection	ASME B16.5	1/2"	150 lbs / RF
Heating with pipe connection for Ermeto	-	E12	PN40

Higher pressure ratings and other connection on request

Materials

RR - stainless steel, HC - Hastelloy, C - ceramic/PTFE, F - food

Device	Measuring tube	Flanges / raised face	Suspended solid particle	Receiver / guide	Circular orifice
H250/RR	CrNi steel 1.4404 ①	CrNi steel 1.4404 massive ①	CrNi steel 1.4404 ①	CrNi steel 1.4404 ①	-
H250/HC	Hastelloy C4 [2.4610]	CrNi steel 2.4610 with Hastelloy C4 [2.4610] plated ①	Hastelloy C4 [2.4610]	Hastelloy C4 [2.4610]	-
H250/C ②	CrNi steel 1.4571 with PTFE liner ③	CrNi steel 1.4571 with PTFE liner ③	HC4, PTFE or Al2O3 with seal: Kalrez KLR 6375 ④	Al2O3 and PTFE	Al2O3
H250/F ⑤	CrNi steel 1.4435	CrNi steel 1.4435	CrNi steel 1.4435	CrNi steel 1.4435	-

① deliverable on request CrNi steel 1.4571, with clamp connections CrNi steel 1.4435

② DN100 / 4" only PTFE

③ PTFE-TFM (electrically nonconductive)

④ Gasket 2035 (Kalrez) or 4079

⑤ wetted surfaces Ra ≤ 0.8 µm

Further options:

- Special material on request: e.g. SMO 254, Titan, 1.4435
- Suspended solid particle decrease: ceramic or PEEK
- Seal for devices with internal thread: O-ring FPM / FKM

Technical data for indicators M8 M9 M10

Indicator M8

M8M limit switch

Clamp connection	2.5mm ²		
Limit switches	SC3,5-N0-Y	SJ3,5-SN	SJ3,5-S1N
Type	2-wire NAMUR	2-wire NAMUR	2-wire NAMUR
Switch configuration	Normally closed	Normally closed	Normally open
Nominal voltage U ₀	8 VDC	8 VDC	8 VDC
Pointer shaft not read	≥3 mA	≥3 mA	≤1 mA
Pointer shaft read	≤1 mA	≤1 mA	≥3 mA

M8E current output

Cable gland	M16 x 1.5	
Pipe diameter	8...10 mm	
Clamp-type terminal	4 mm ²	
Measuring signal	4...20 mA for 0...100% flow value	Two-wire technology
Power supply	14.8...30 Volt DC	
Min. power supply at HART™	20.5 Vdc	
Power supply effect	< 0.1%	
Input impedance dependence	< 0.1%	
Temperature effect	< 10µA / K	
Max. input impedance / load	640 Ohm (30VDC)	
Min. load at HART™	250 Ohm	

M8E HART

M8E HART™ Parameterization		
Manufacturer's name (code)	KROHNE Messtechnik (69)	
Model name	M8E (230)	
HART™ Protocol revision	5.1	
Device revision	1	
Physical layer	FSK	
Device category	Transmitter	

M8E process variable

M8E process variable flowrate	Values [%]	Signal output [mA]
Over range	+105 (± 1%)	20.64...20.96
Device error identification	> 110	> 21.60
Maximum	112.5	22
Multi drop operation	-	4.5

Indicator M9

M9 cable fitting

Cable fitting	Material	Cable diameter
M 16x1.5 Standard	PA	5...10 mm
M 20x1.5	PA	8...13 mm
M 16x1.5	Nickel-plated brass	5...9 mm
M 20x1.5	Nickel-plated brass	10...14 mm

M9 limit switches

Clamp connection	2.5mm ²			
Limit switches	SC3,5-N0-Y	SJ3,5-SN	SJ3,5-S1N	SB3,5-E2
Type	2-wire NAMUR	2-wire NAMUR	2-wire NAMUR	3-wire
Switch configuration	Normally closed	Normally closed	Normally open	PNP normally open
Nominal voltage U ₀	8 V	8 V	8 V	10...30 V
Pointer shaft not read	≥3 mA	≥3 mA	≤1 mA	≤ 0.3 V
Pointer shaft read	≤1 mA	≤1 mA	≥3 mA	V _b - 3 V
Continuous current	-	-	-	max. = 100 mA
No-load current I ₀	-	-	-	≤15 mA

M9 current output ESK2A

Clamp connection	2.5 mm ²	
Power supply	12...30 VDC	
Measurement signal	4.00...20.00 mA for 0...100% flow value	Two-wire technology
Power supply	12...30 VDC	
Min. power supply for HART™	18 VDC	
Effect of supply power	< 0.1%	
External resistance dependence	< 0.1%	
Temperature influence	< 5 mA / K	
Max. external resistance / load impedance	800 ohms (30 VDC)	
Min. load with HART™	250 ohms	

M9 ESK2A HART

ESK2A HART™ parameter configuration		
Name of manufacturer (code)	KROHNE Messtechnik (69 = 45h)	
Name of model	ESK2A (226 = E2h)	
HART™ protocol revision	5.9	
Device revision	1	
Physical layer	FSK	
Device category	Transmitter non dc isolated device	

M9 ESK2A process variable

ESK2A process variable flow rate	Values [%]	Signal output [mA]
Over range	+102.5 (± 1%)	20.24...20.56
Device error detection	> 106.25	> 21.00
Maximum	131.25	25
Multi-drop operation	-	4.5
Lift-off voltage	12 VDC	

M9 ESK totalizer

Clamp connection	2.5 mm ²	
Power supply	10...30 VDC	
R _{ext.} Current loop	0...600 ohms	
Power consumption	max. 2.5 watts	
Max. external resistance / load impedance	720 ohms	depending on power supply
Indicating error	< 1%	maximum one scalar unit
Max. reset voltage	30 VDC	
Min. reset pulse	20 ms	
	.	
Power supply	10...30 VDC	
Max. current	50 mA	
Max. dissipation	250 mW	
T on	80 ms	fixed pulse width
T off	depends on flow rate	
V on	V _b – 3 volts	
V off	0 volts	
Pulse value	1 pulse = 1 display totalizer advance	= 1 flow unit (1 liter, 1 m ³ ...)

M9 ESK3PA

Clamp connection	2.5mm ²	
Bus cable R´	15...150 ohms/km	
Bus cable L´	0.4...1 NH/km	
Bus cable C´	80...200 nF/km.	

M9 ESK3PA hardware

Hardware	according to IEC 1158-2 and FISCO model	
Power supply	9...32 VDC	
Base current	12 mA	
Starting current	< Base current	
FDE	< 18 mA	
Accuracy as per VDI/ VDE 3513	1.6	
Measurement resolution	< 0.1 % of full-scale value	
Temperature influence	< 0.05 % / K of full-scale value	

M9 ESK3PA software

Software		
GSD	Device master file	
Device profile	Profiles B, V3.0	
Function blocks		
Flow rate (A10)	Volume or mass	
Totalizer (TOT0)	Volume totalizer	Default units: [m3]
Totalizer (TOT1)	Mass totalizer	Default units: [kg]
Address range	0...126, default 126	
SAP's	Service_Access_Points	
DD	Device description	

Indicator M10

M10 indicator

Cable fitting	none	[standard]
M 20x1.5	on request	
M 20x1.5 Ex d	on request	

M10 current output

current output	Two-wire technology	
Power supply	24 VDC +/- 30	
Signal output current	4...20 mA	
Effect of supply power	< 0.1	
External resistance dependence	< 0.1	
Temperature influence	< 5 uA/K	
External resistance / load impedance	≤ 630 ohms	
External resistance with HART	≥ 250 ohms	

M10 HART

Name of manufacturer (code)	KROHNE Messtechnik (69)	
Name of model	M10A	
HART™ protocol revision	5.1	
Device revision	1	
Physical layer	FSK	
Device category	Transmitter	

M10 process variable

	Values [%]	Signal output [mA]
Over range	+105 (± 1%)	20.64...20.96
Device error detection	> 110	> 21.60
Maximum	112.5	22
Multi-drop operation	-	4.5

M10 digital output

Binary outputs	galvanically isolated	
Operating mode	Binary output	NAMUR or open collector
configurable as	switching contact	normally open / normally closed or
	pulse output	max. 10 pulses per second
NAMUR binary output		
Power supply	8 V	
Signal current	> 3 mA if switching value not reached;	

	< 1 mA when switching value reached	
Open collector binary output		
Power supply	8...30 VDC	
Pmax	500 mW	
I _{max}	100 mA	

M10 reset input

Binary input	galvanically isolated	
Operating mode	Counter reset	
configurable as	active HI / active LO	
Voltage level	5...30 VDC	
Current drawn	≤1 mA	
Pulse length (active)	≥ 500 ms	

Dimensions

Dimensions of H250/M9

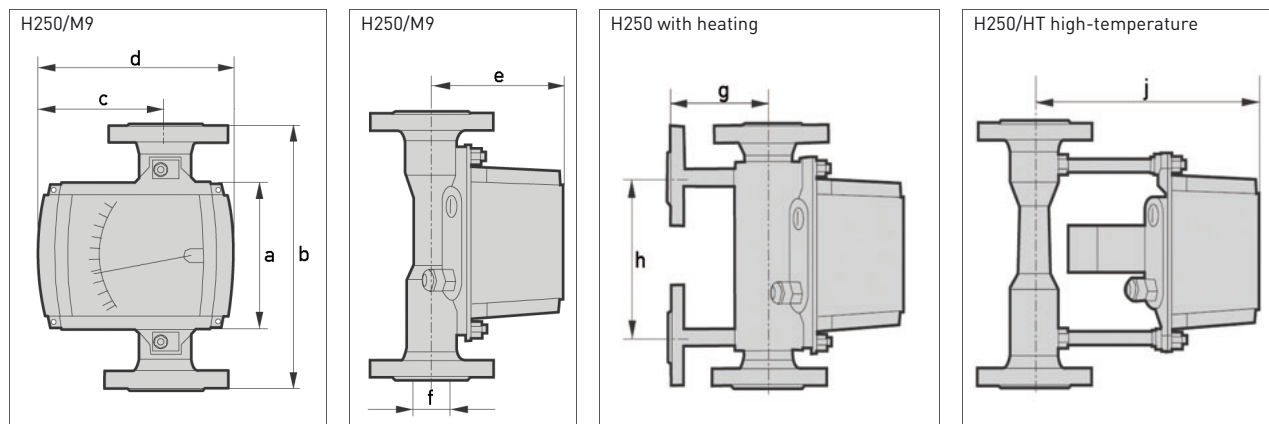

	Dimensions [mm]									
	a	b	c	d	e	Ø f	g	h	j	
DN15 PN40	138	250	110.5	181	107	20	100	150	187	
DN25 PN40	138	250	110.5	181	119	32	106	150	199	
DN50 PN40	138	250	123.5	181	132	65	120	150	212	
DN80 PN40	138	250	123.5	181	148	89	160	150	228	
DN100 PN40	138	250	123.5	181	158	114	150	150	232	

Installation height of H250/C (ceramic/PTFE) from 3"/300 lbs: 300 mm

Installation height of H250/F (food) with threaded connection per ISO 228 with internal thread: 300 mm

Dimensions of H250/M10 /M8

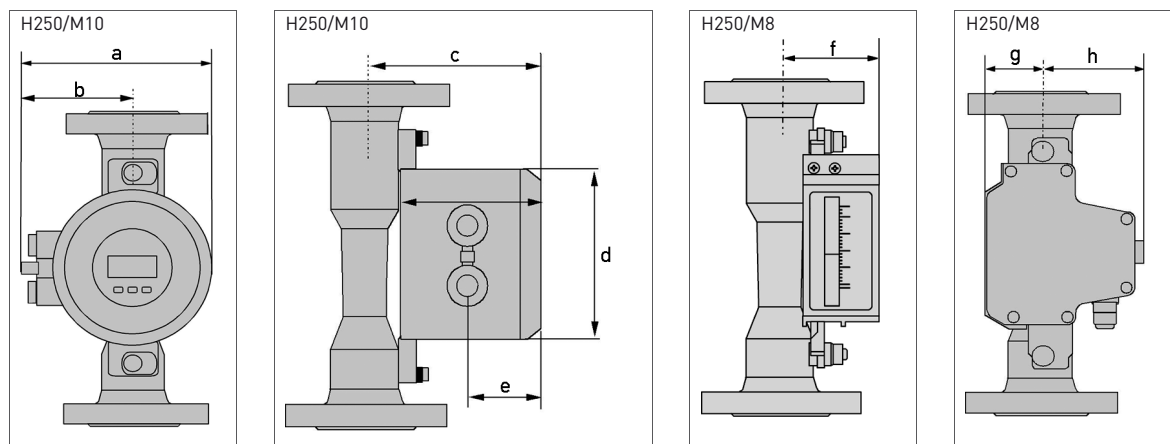

	M10 dimensions [mm]					M8M dimensions [mm]			M8E dimensions [mm]		
	a	b	c	d	e	f	g	h	f	g	h
DN15 PN40	147	83	118	∅ 132	55	63	60	58.5	53.5	66	52.5
DN25 PN40	147	83	130	∅ 132	55	75	60	58.5	65.5	66	52.5
DN50 PN40	147	83	143	∅ 132	55	89	73	45.5	79.5	79	39.5
DN80 PN40	147	83	160	∅ 132	55	105	73	45.5	95.5	79	39.5
DN100 PN40	147	83	169	∅ 132	55	114	73	45.5	104.5	79	39.5

Measuring ranges

H250/RR - stainless steel, H250/HC - Hastelloy

Measuring span 10 : 1

Flow values 100%

H250/RR, H250/HC, H250/F		Water			Air			Max. pressure loss			
Float ▶		TIV	CIV	DIV	TIV (Alu)	TIV	DIV	TIV Alu	TIV	CIV	DIV
Nominal diameter	Cone	[l/h]	[l/h]	[l/h]	[m3/h]	[m3/h]	[m3/h]	[mbar]	[mbar]	[mbar]	[mbar]
DN15 1/2"	K 15.1	18	25	-	0.42	0.7	-	12	21	26	-
	K 15.2	30	40	-	0.7	1	-	12	21	26	-
	K 15.3	55	63	-	1	1.5	-	12	21	26	-
	K 15.4	80	100	-	1.7	2.2	-	12	21	26	-
	K 15.5	120	160	-	2.5	3.6	-	12	21	26	-
	K 15.6	200	250	-	4.2	5.5	-	12	21	26	-
DN25 1"	K 15.7	350	400	700	6.7	10	18 ①	12	21	28	38
	K 15.8	500	630	1000	10	14	28 ①	13	22	32	50
	K 15.8	-	-	1600 ②	-	-	50 ②	-	-	-	85
	K 25.1	480	630	1000	9.5	14	-	11	24	32	72
	K 25.2	820	1000	1600	15	23	-	11	24	33	74
DN50 2"	K 25.3	1200	1600	2500	22	35	-	11	25	34	75
	K 25.4	1700	2500	4000	37	50	110 ①	12	26	38	78
	K 25.5	3200	4000	6300	62	95	180 ①	13	30	45	103 ③
DN80 3"	K 55.1	2700	6300	8400	58	80	230 ①	8	13	74	60
	K 55.2	3600	10000	14000	77	110	350 ①	8	13	77	69
	K 55.3	5100	16000	25000	110	150	700 ①	9	13	84	104
DN100 4"	K 85.1	12000	25000	37000	245	350	1000 ①	8	16	68	95
	K 85.2	16000	40000	64000	280	400	1800 ①	9	16	89	125
DN100 4"	K105.1	19000	63000	100,000	-	550	2800 ①	-	-	120	220

① P > 0.5 bar

② with TR float

③ 300 mbar with damping (gas measurement)

Reference condition:

Water 20°C

Air 20°C - 1.013bar abs.

Notes:

- Air measurement - TIV suspended solid particles: Heating not possible
- The indicated pressure losses apply for water and air at maximum flow.
- Other flow rate measuring ranges can be provided upon request.
- The conversion of other process fluids or operating data (pressure, temperature, density, viscosity) is done at KROHNE with the help of the calculation procedure as detailed in VDE /VDI Directive 3513

H250/C - Ceramic/PTFE

Measuring span 10 : 1

Flow values 100%

H250/C		Flow			Max. pressure loss		
		Water		Air	Water		Air
Liner / float ▶		PTFE	Ceramic	Ceramic	PTFE	Ceramic	Ceramic
Nominal diameters	Cone	[l/h]	[l/h]	[m ³ /h]	[mbar]	[mbar]	[mbar]
DN15, 1/2"	E 17.2	25	30	-	65	62	62
	E 17.3	40	50	1.8	66	64	64
	E 17.4	63	70	2.4	66	66	66
	E 17.5	100	130	4	68	68	68
	E 17.6	160	200	6.5	72	70	70
	E 17.7	250	250	9	86	72	72
	E 17.8	400	-	-	111	-	-
DN25, 1"	E 27.1	630	500	18	70	55	55
	E 27.2	1000	700	22	80	60	60
	E 27.3	1600	1100	30	108	70	70
	E 27.4	2500	1600	50	158	82	82
	E 27.5	4000 ①	2500	75	290	100	100
DN50, 2"	E 57.1	4000	4500	140	81	70	70
	E 57.2	6300	6300	200	110	80	80
	E 57.3	10000	11000	350	170	110	110
	E 57.4	16000 ①	-	-	284	-	-
DN80, 3"	E 87.1	16000	16000	-	81	70	-
	E 87.2	25000	25000	-	95	85	-
	E 87.3	40000 ①	-	-	243	-	-
DN100, 4"	E 107.1	40000	-	-	100	-	-
	E 107.2	60000 ①	-	-	225	-	-

① special float

Reference condition:

Water 20°C

Air 20°C - 1.013bar abs.

Notes:

- The indicated pressure losses apply for water and air at maximum flow.
- Other flow rate measuring ranges can be provided upon request.
- The conversion of other process fluids or operating data (pressure, temperature, density, viscosity) is done at KROHNE with the help of the calculation procedure as detailed in VDE /VDI Directive 3513

H250H - horizontal installation

Measuring span 10 : 1

Flow values 100%

	Suspended solid particle shape	Cone no.	Flow, water [l/h]		Pressure loss [mbar]	
			Spring A	Spring B	Spring A	Spring B
DN15	DIV TB	K 15.1	70		195	
		K 15.2	120		204	
		K 15.3	180		195	
		K 15.4	280		225	
		K 15.5	450		250	
		K 15.6	700		325	
		K 15.7	1200		590	
		K 15.8	1600	2400	950	1600
DN25	DIV T	K 25.1	1300		122	
		K 25.2	2000		105	
		K 25.3	3000		116	
		K 25.4	5000		145	
		K 25.5	8500	10000	217	336
DN50	DIV T	K 55.1	10000		240	
		K 55.2	16000		230	
		K 55.3	22000	34000	220	420
DN80	DIV T	K 85.1	25000		130	
		K 85.2	35000	60000	130	290
DN100	DIV L	K 105.1	80000	120000	250	340

Reference condition:

Water 20°C

Notes:

- The indicated pressure losses apply for water at maximum flow.
- Other flow rate measuring ranges can be provided upon request.
- Conversion of other process fluids or operating data as detailed in VDE /VDI Directive 3513

H250U - vertical installation - direction of flow from top down

Measuring span 10 : 1

Flow values 100%

	Suspended solid particle shape	Cone no.	Flow, water [l/h]	Pressure loss [mbar]
DN15	DIV TB	K 15.1	65	175
		K 15.2	110	178
		K 15.3	170	180
		K 15.4	260	200
		K 15.5	420	220
		K 15.6	650	290
		K 15.7	1100	520
		K 15.8	1500	840
DN25	DIV T	K 25.1	1150	97
		K 25.2	1800	85
		K 25.3	2700	92
		K 25.4	4500	115
		K 25.5	7600	172
DN50	DIV T	K 55.1	9000	220
		K 55.2	15000	230
		K 55.3	21000	240

Reference condition:

Water 20°C

Notes:

- The indicated pressure losses apply for water at maximum flow.
- Other flow rate measuring ranges can be provided upon request.
- Conversion of other process fluids or operating data as detailed in VDE /VDI Directive 3513

Temperatures H250/M9 - mechanical display without power supply

	Suspended solid particle	Liner	Measuring temp. [°C]	Ambient temp. [°C]
H250/RR	Stainless steel	Stainless steel	+300	
H250/HC	Hastelloy C4	Hastelloy C4	+300	
H250/C	PTFE	PTFE	+70	+70
H250/C	Ceramic	PTFE	+150	+70
H250/C	Ceramic	TFM	+250	+120
H250H - H250U			+100	
Min. temperature of medium				
Standard			-196	
H250H H250U			-40	
Ambient temperatures				
Standard				-40...+120
Screw fitting				-20...+120
H250H H250U				-20...+90

Temperatures H250/M9 - with electrical components

DIN	ASME	Version with	TS °C (Tamb. <40 °C)		TS °C (Tamb. <60 °C) *	
			Standard	HT	Standard	HT
DN15, DN25	1/2", 1"	ESK II, ESK-S, ESK3-PA	+200	+300	+180	+300
		ESK II with counter	+200	+200	+80	+130
		Limit monitors SC.. SJ..	+200	+300	+200	+300
		Limit monitor SB..	+200	+300	+130	+295
DN 50	2"	ESK II, ESK-S, ESK3-PA	+200	+300	+165	+300
		ESK II with counter	+180	+300	+75	+100
		Limit monitors SC.. SJ..	+200	+300	+200	+300
		Limit monitor SB..	+200	+300	+120	+195
DN 80, DN100	3", 4"	ESK II, ESK-S, ESK3-PA	+200	+300	+150	+250
		ESK II with counter	+150	+270	+70	+85
		Limit monitors SC.. SJ..	+200	+300	+200	+300
		Limit monitor SB..	+190	+300	+110	+160

* without heat insulation measures, a heat-resistant cable is necessary (continuous operating temperature of the cable to be used: 100°C)

Abbreviations:

- HT- High temperature version
- ESK 2A- Power transmitter, two-wire technology 4 ... 20 mA
- ESK3-PA- PROFIBUS transmitter
- SC- Limit monitor type NAMUR
- SJ- Limit monitor type NAMUR, security-relevant
- SB- Limit monitor type, 3-wire, open collector

Temperatures H250 /M8 /M10

M8M

Max. Tmed. at Tamb. +60°C	+200
Min. measuring temperature TS without limit monitor	-80
Min. measuring temperature TS with limit monitor	-25
Max. ambient temperature Tamb.	+70
Min. ambient temperature Tamb.	-25

M8E

Max. Tmed. at Tamb. +40°C	+200
Max. Tmed. at Tamb. +50°C	+185
Max. Tmed. at Tamb. +60°C	+145
Min. Tmed.	-25
Max. ambient temperature Tamb.	+70
Min. ambient temperature Tamb.	-25

M10

Max. Tmed. at Tamb. +60°C	+200
Min. measuring temperature TS	-80
Max. ambient temperature Tamb.	+75
Min. ambient temperature Tamb.	-40

KROHNE Product Overview

- Electromagnetic flowmeters
- Variable area flowmeters
- Mass flowmeters
- Ultrasonic flowmeters
- Vortex flowmeters
- Flow controllers
- Level measuring instruments
- Pressure gauges
- Temperature measuring instruments
- Water solutions & analysis
- Oil and gas turnkey solutions

Addresses:

Germany

Northern sales office

KROHNE Messtechnik GmbH & Co. KG
Bremer Str. 133
D-21073 Hamburg
Phone: +49 (0)40 767 3340
Fax: +49 (0)40 767 33412
nord@krohne.de
ZIP code: 10000 - 29999, 49000 - 49999

Western and middle sales office

KROHNE Messtechnik GmbH & Co. KG
Ludwig-Krohne-Straße
D-47058 Duisburg
Phone: +49 (0)203 301 416
Fax: +49 (0)203 301 10416
west@krohne.de
ZIP code: 30000 - 34999, 37000 -
48000, 50000 - 53999, 57000 - 59999,
98000 - 99999

Southern sales office

KROHNE Messtechnik GmbH & Co. KG
Landsberger Str. 392
D-81241 Munich
Phone: +49 (0)89 121 5620
Fax: +49 (0)89 129 6190
sued@krohne.de
ZIP code: 0 - 9999, 80000 - 89999,
90000 - 97999

Southwestern sales office

KROHNE Messtechnik GmbH & Co. KG
Rüdesheimer Str. 40
D-65239 Hochheim/Main
Phone: +49(0)6146) 827 30
Fax: +49 (0)6146 827 312
rhein-main@krohne.de
ZIP code: 35000 - 36999, 54000 -
56999, 60000 - 79999

Instrumentation and control equipment catalog

TABLAR Messtechnik GmbH
Ludwig-Krohne-Straße 5
D-47058 Duisburg
Phone: +49 (0)2 03 305 880
Fax: +49 (0)2 03 305 8888
kontakt@tablar.de www.tablar.de

KROHNE sales companies

International

Australia

KROHNE Australia Pty Ltd
Quantum Business Park 10/287
Victoria Rd Rydalmere NSW 2116
Phone: +61 2 8846 1700
Fax: +61 2 8846 1755
krohne@krohne.com.au

Austria

KROHNE Austria Ges.m.b.H.
Modecenterstraße 14
A-1030 Vienna
Phone: +43 (0)1/203 45 32
Fax: +43 (0)1/203 47 78
info@krohne.at

Belgium

KROHNE Belgium N.V.
Brusselstraat 320
B-1702 Groot Bijgaarden
Phone: +32 (0)2 4 66 00 10
Fax: +32 (0)2 4 66 08 00
krohne@krohne.be

Brazil

KROHNE Conaut Controles
Automaticos Ltda.
Estrada Das Águas Espriaiadas, 230
C.P. 56 06835 - 080 EMBU - SP
Phone: +55 (0)11-4785-2700
Fax: +55 (0)11 4785-2768
conaut@conaut.com.br

China

KROHNE Measurement Instruments
(Shanghai) Co. Ltd., (KMIC)
Room 1501
1033 Zhaojiabang Road
Shanghai 200030
Phone: +86 21 6487 9611
Fax: +86 21 6438 7110
info@krohne-asia.com

Czech Republic
Sobisická 156
63800 Brno
Phone: +420 (0)545.242 627
Fax: +420 (0)545 220 093
brno@krohne.cz

France

KROHNE S.A.S.
Les Ors BP 98
F-26103 ROMANS Cedex
Phone: +33 (0)4 75 05 44 00
Fax: +33 (0)4 75 05 00 48
info@krohne.fr

Great Britain

KROHNE Ltd.
Rutherford Drive
Park Farm Industrial Estate
Wellingborough
Northants NN8 6AE
Phone: +44 (0)19 33 408 500
Fax: +44 (0)19 33 408 501
info@krohne.co.uk

CIS

Kanex KROHNE Engineering AG
Business-Centre Planeta
Office 404 ul.
Marxistskaja 3
109147 Moscow/Russia
Phone: +7 (0)095 911 7165
Fax: +7 (0)095 742 8873
krohne@ddol.ru

India

Krohne Marshall Ltd.
A-34/35, M.I.D.C. Industrial Area,
H-Block
Pimpri Poona 411018
Phone: +91 (0)202 744 2020
Fax: +91 (0)202 744 2020
pcul@vsnl.net

Iran

KROHNE Liaison Office
North Sohrevardi Ave. 26,
Sarmad St., Apt. #9
Tehran 15539
Phone: +9821 8874 5973
Fax: +9821 8850 1268
krohne@krohneiran.com

Italy

KROHNE Italia Srl.
Via V. Monti 75
I-20145 Milan
Phone: +39 02 4300 661
Fax: +39 02 4300 6666
info@krohne.it

Korea

KROHNE Korea
Room 508 Miwon Bldg 43
Yoido-Dong Youngdeungpo-Ku
Seoul, Korea
Phone: 00-82-2-782-1900
Fax: 00-82-2-780-1749
krohnekorea@krohnekorea.com

Netherlands

KROHNE Nederland B.V.
Kerkeplaat 14
NL-3313 LC Dordrecht
Phone: +31 (0)78 630 6200
Fax: +31 (0)78 630 6405
Service Direct: +31 (0)78 630 6222
info@krohne.nl

Norway

KROHNE Norway A.S.
Ekholtveien 114
NO-1521 Moss
Phone: +47 (0)69 264 860
Fax: +47 (0)69 267 333
postmaster@krohne.no

Poland

KROHNE Polska Sp.z.o.o.
ul. Stary Rynek Oliwski 8a
80-324 Gdansk
Phone: +48 (0)58 520 9211
Fax: +48 (0)58 520 9212
info@krohne.pl

Switzerland

KROHNE AG
Uferstr. 90
CH-4019 Basel
Phone: +41 (0)61 638 30 30
Fax: +41 (0)61 638 30 40
info@krohne.ch

Singapore

Tokyo Keiso - KROHNE (Singapore)
Pte. Ltd.
14, International Business Park,
Jurong East
Chiyoda Building, #01-01/02
Singapore 609922
Phone: (65) 6567 4548
Fax: (65) 6567 9874
tks@tokyokeiso-krohne.com.sg

Republic of South Africa

KROHNE Pty. Ltd.
Bushbock Close
Corporate Park South
Midrand, Gauteng
P.O. Box 2069
Midrand, 1685
Phone: +27 (0)11 314 1391
Fax: +27 (0)11 314 1681
midrand@krohne.co.za

Spain

I.I. KROHNE IBERIA, S.r.l.
Poligono Industrial Nilo
Calle Brasil, nº. 5
28806 Alcalá de Henares Madrid
Phone: +34 (0)91 883 2152
Fax: +34 (0)91 883 4854
krohne@krohne.es

USA

KROHNE, Inc.
7 Dearborn Road
Peabody, MA 01960
Phone: +1 (800) FLOWING
Phone: +1 (978) 535 6060 (in MA)
info@krohne.com

Representatives

Algeria
Argentina
Cameroon
Canada
Chile
Columbia
Croatia
Denmark
Ecuador
Egypt
Finland
Gabon
Ghana
Greece
Hong Kong
Hungary
Indonesia
Iran
Ireland
Israel
Ivory Coast
Japan
Jordan
Kuwait
Libya
Lithuania
Malaysia
Mauritius
Mexico
Morocco
New Zealand
Peru
Portugal
Romania
Saudi Arabia
Senegal
Slovakia
Slovenia
Sweden
Taiwan
Thailand
Tunisia
Turkey
Venezuela
Yugoslavia

Other countries

KROHNE Messtechnik GmbH & Co. KG
Ludwig-Krohne-Str. 5
D-47058 Duisburg
Phone: +49 (0)203 301 0
Fax: +49 (0)203 301 389
export@krohne.de