

Variable Area Flowmeter, Plastic

Construction

The flowmeter operates according to the variable area principle. Metering tubes are available in PA transparent or Polysulphone suitable for inert or corrosive* media (PVC-U and PVDF tubes on request). Male threads moulded onto the ends of the metering tube allow for easy mounting of unions.

O-ring seals at the faces of the tube ensure reliable sealing between metering tube and union and provide stress-free sealing. The floats are available in stainless steel 1.4571, PVC-U, PP or PVDF (depending on working medium and measuring range). The scale on the metering tube can be suited to the medium and is available e.g. in l/h, m³/h or %.

Dovetail sections moulded onto the metering tube allow for easy mounting of adjustable visual flow indicators, limit switches and a continuous readout transmitter.

Advantages

- Good level of accuracy, simple operation
- Corrosion resistant
- Over 500 standard scales and 13,000 special scales are available with further scales on request
- Clear and large size printed scale
- Versions according to ATEX available on request

* see information on working medium on page 2

Sectional drawing

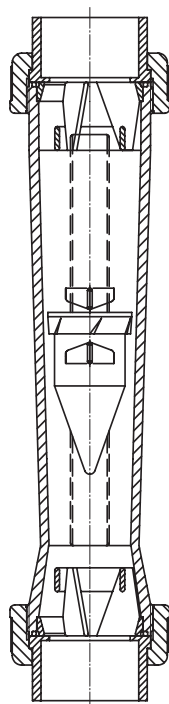

GEMÜ® 800

801/805/807/811/815/817/820
822/825/830/831/832/835

Technical data

Working medium

Corrosive and inert gaseous and liquid media which have no negative impact on the physical and chemical properties of the metering tube, float, seal and union materials.

Operating pressure*

Metering tubes with plastic unions max. 10 bar
 Metering tubes with metal unions max. 15 bar

*Operating pressure dependent on tube material and operating temperature

Version

Type	Working medium	Float material
801	Liquids and gases	PVC-U
811 / 831	Liquids and gases	PVC-U with magnet
805	Liquids and gases	PP
815	Liquids and gases	PP with magnet
807	Liquids and gases	Stainless steel 1.4571
817	Liquids and gases	Stainless steel 1.4571 with magnet
825	Gases	PP
835	Liquids and gases	PP with magnet
820 / 822	Liquids and gases	PVDF
830 / 832	Liquids and gases	PVDF with magnet

Pressure / temperature correlation - Variable area flowmeter

Tube material	Union material	Code	Temperature in °C																
			-20	-10	±0	5	10	20	25	30	40	50	60	70	80	90	100	110	120
PA transparent code 21	PVC-U	1	-	-	-	10	10	10	10	8.0	6	3.5	1.5	-	-	-	-	-	-
	PP	5	-	-	-	10	10	10	10	8.5	7	5.5	4.0	-	-	-	-	-	-
	PVDF	20	10	10	10	10	10	10	10	9.0	8	7.1	6.3	-	-	-	-	-	-
	Malleable iron	6	15	15	15	15	15	15	15	13.5	12	10.7	9.5	-	-	-	-	-	-
	Stainless steel	7	15	15	15	15	15	15	15	13.5	12	10.7	9.5	-	-	-	-	-	-
Poly-sulphone code 22	PVC-U	1	-	-	-	10	10	10	10	8.0	6	3.5	1.5	-	-	-	-	-	-
	PP	5	-	-	-	10	10	10	10	8.5	7	5.5	4.0	2.7	1.5	0.8	-	-	-
	PVDF	20	-	-	-	10	10	10	10	9.0	8	7.1	6.3	5.4	4.7	3.6	2.5	-	-
	Malleable iron	6	-	-	-	15	15	15	15	14.0	13	12.0	11.0	9.7	8.5	7.7	6.0	-	-
	Stainless steel	7	-	-	-	15	15	15	15	14.0	13	12.0	11.0	9.7	8.5	7.7	6.0	-	-
PVC-U, transparent code 3	PVC-U	1	-	-	-	10	10	10	10	8.0	6	3.5	-	-	-	-	-	-	-
	Malleable iron	6	-	-	-	10	10	10	10	8.0	6	3.5	-	-	-	-	-	-	-
	Stainless steel	7	-	-	-	10	10	10	10	8.0	6	3.5	-	-	-	-	-	-	-
	Stainless steel/PP	1V	-	-	-	10	10	10	10	8.0	6	3.5	-	-	-	-	-	-	-
PVDF code 20	PVDF	20	10	10	10	10	10	10	10	9.0	8	7.1	6.3	5.4	4.7	3.6	2.5	1.7	1.2
	Stainless steel	7	10	10	10	10	10	10	10	9.0	8	7.1	6.3	5.4	4.7	3.6	2.5	1.7	1.2
	Stainless steel/PVDF	2V	10	10	10	10	10	10	10	9.0	8	7.1	6.3	5.4	4.7	3.6	2.5	1.7	1.2

Pressure loss [mbar]

Type	Nominal size					
	20	25	32	40	50	65
801, 805, 811, 815, 820, 830	8	10.0	13.0	15	20.0	24
807, 817	17	19.0	27.0	30	41.0	50
825	2	2.5	3.5	4	5.5	6
831, 835	11	13.0	18.0	20	28.0	34
822, 832	-	-	-	-	26.5	-

Order data

Version	
Float material	Type
PVC-U (liquids and gases)	801
PVC-U with magnet (liquids and gases)	811 / 831
PP (liquids and gases)	805
PP with magnet (liquids and gases)	815
Stainless steel 1.4571 (liquids and gases)	807
Stainless steel 1.4571 with magnet (liquids and gases)	817
PP (gases)	825
PP with magnet (liquids and gases)	835
PVDF (liquids and gases)	820 / 822
PVDF with magnet (liquids and gases)	830 / 832

Body configuration	Code
Straight through	D

Connection	Code
Union ends with DIN insert (socket)	7
Union ends with inch insert (socket)	33
Union ends with DIN insert (butt welding)	71
Union ends with DIN insert (IR butt welding)	78
Union ends with insert (threaded socket Rp)	7R
Spigots DIN 11850, series 2	17
Spigots SMS 3008	37
Spigots ASME BPE	59
Spigots EN ISO 1127	60
Flanged connection on request	

Tube material	Code
PVC-U on request	3
PVDF on request	20
PA transparent temperature range 0 to 60°C*	21
Polysulphone temperature range 0 to 100°C*	22

* Stated temperatures are valid for water

Seal material	Code
O-ring FPM	4
O-ring EPDM	14
O-ring FEP encapsulated	55

Union material	Code
Insert PVC-U, union nut PP	1
Insert PP, union nut PP	5
Malleable iron	6
Insert 1.4571 (threaded socket Rp) union nut stainless steel	7
Insert PVDF, union nut PVDF	20
Insert 1.4435 (butt weld spigot) union nut stainless steel	41
Insert 1.4435 (butt weld spigot) or Insert 1.4571 (threaded socket Rp), union nut PP	1V
Insert 1.4435 (butt weld spigot) or Insert 1.4571 (threaded socket Rp), union nut PVDF	2V
* Other materials on request	

Tube size	Code
See tables on pages 4 and 5	

Measuring range	Code
See tables on pages 4 and 5	
Always state the maximum measuring range value when ordering.	

Note:

The scale divisions given on pages 4 and 5 correspond to the actual flows.
When ordering, the flow ranges should be stated as follows:
Liquid media: l/h
Gaseous media: Nm³/h

Ordering information:

The following data are necessary:

1. Type of medium
2. Concentration of medium (%)
3. Required flow range (l/h, m³/h, kg/h)
4. Operating pressure, relative or absolute (bar)
5. Temperature of medium (°C)
6. Viscosity of medium
7. Medium density
8. Float with or without magnet

Order example	805	25	D	7	21	14	1	52	250
Version (type)	805								
Nominal size (code)		25							
Body configuration (code)			D						
Connection (code)				7					
Tube material (code)					21				
Seal material (code)						14			
Union material (code)							1		
Tube size (code)								52	
Measuring range max. (e.g. 250 l/h H ₂ O)									250

Accuracy class: 4 acc. to VDE/VDI 3513, sheet 2, i.e. $\pm 1\%$ of end value and $\pm 3\%$ of measured value.

Selection of scales */** (liquid media)

Type	Nominal size	Water H ₂ O	Hydrochloric acid HCl 30-33%	Sodium hydroxide NaOH 30%	Sodium hydroxide NaOH 50%	Scale	Tube size	Weight		
		Tube						Union		
		PA transp./ Polysulphone	Polysulphone	PA transparent / Polysulphone		%		Code	PVC-U	Malleable iron
		DN	l/h						[kg]	
801/811 Float material PVC-U (GEMÜ 811 with magnet)	20	15 - 160	10 - 130	2.5 - 57.5	0.5 - 10.0	10 - 100	46	0.42	0.53	
		20 - 250	20 - 210	5.0 - 115.0	1.0 - 23.0		47	0.42	0.53	
		40 - 400	40 - 340	10.0 - 210.0	2.5 - 57.5		48	0.42	0.53	
		50 - 650	50 - 550	20.0 - 380.0	5.0 - 135.0		49	0.41	0.52	
805/815 Float material PP (GEMÜ 815 with magnet)	25	20 - 250	20 - 210	5 - 125	1.0 - 20	10 - 100	52	0.57	0.74	
		40 - 400	20 - 350	10 - 200	2.5 - 50		53	0.56	0.73	
		60 - 640	50 - 550	10 - 390	5.0 - 130		54	0.55	0.72	
		100 - 1000	75 - 900	25 - 650	10.0 - 260		55	0.54	0.71	
820/830 Float material PVDF (GEMÜ 830 with magnet)	32	100 - 1000	75 - 900	25 - 600	10 - 200	10 - 100	61	0.98	1.25	
		150 - 1600	100 - 1500	50 - 1100	20 - 500		62	0.96	1.23	
		200 - 2500	200 - 2300	100 - 1700	25 - 950		63	0.94	1.21	
822/832 Float material PVDF (GEMÜ 832 with magnet)	40	150 - 1600	100 - 1450	50 - 1000	25 - 425	10 - 100	67	1.24	1.56	
		200 - 2500	200 - 2200	100 - 1700	25 - 900		68	1.21	1.52	
		300 - 3300	300 - 2800	100 - 2100	50 - 1250		69	1.20	1.52	
		200 - 2500	200 - 2300	50 - 1700	25 - 800		71	1.52	2.39	
807/817 Float material 1.4571 (GEMÜ 817 with magnet)	50	400 - 4000	300 - 3600	100 - 2800	50 - 1600	10 - 100	72	1.49	2.36	
		600 - 6400	500 - 6000	250 - 5000	100 - 3200		73	1.44	2.31	
		750 - 9000	750 - 8000	500 - 6750	250 - 4250		75	2.42	3.87	
807/817 Float material 1.4571 (GEMÜ 817 with magnet)	65	1500 - 13000	1500 - 11500	750 - 9750	250 - 6750	10 - 100	77	2.42	3.87	
		1000 - 11000	-	-	-		73	1.44	2.31	
807/817 Float material 1.4571 (GEMÜ 817 with magnet)	20	20 - 250	-	5 - 125	1 - 27	10 - 100	46	0.45	0.56	
		40 - 400	-	10 - 240	2.5 - 70		47	0.45	0.56	
		60 - 640	-	25 - 425	5 - 170		48	0.45	0.56	
		75 - 1000	-	25 - 725	10 - 350		49	0.44	0.55	
	25	40 - 400	-	10 - 240	2.5 - 65	10 - 100	52	0.62	0.79	
		60 - 640	-	20 - 420	5.0 - 145		53	0.61	0.78	
		100 - 1000	-	25 - 700	10.0 - 330		54	0.60	0.77	
		150 - 1600	-	50 - 1200	25.0 - 675		55	0.59	0.76	
	32	150 - 1600	-	50 - 1150	25 - 550	10 - 100	61	1.11	1.38	
		200 - 2500	-	100 - 1900	50 - 1100		62	1.09	1.36	
		400 - 4000	-	200 - 3200	100 - 2000		63	1.07	1.34	
	40	200 - 2500	-	100 - 1700	50 - 1000	10 - 100	67	1.42	1.74	
		400 - 4000	-	200 - 3000	50 - 1900		68	1.39	1.71	
		500 - 5000	-	200 - 3700	100 - 2500		69	1.38	1.70	
	50	400 - 4000	-	100 - 3000	50 - 1800	10 - 100	71	2.00	2.87	
		600 - 6400	-	250 - 5000	100 - 3300		72	1.97	2.84	
1000 - 10000		-	500 - 8500	250 - 6000	73		1.92	2.79		
65	1500 - 14000	-	1000 - 11500	250 - 8500	10 - 100	75	3.31	4.60		
	2000 - 20000	-	1500 - 16500	500 - 12500		77	3.31	4.60		

* All scales in this data sheet are based on a medium temperature of 20° C.

** For smaller or larger flow ranges see data sheets GEMÜ 840, 850.

Tubes in PVC-U and PVDF on request

Selection of scales (gaseous media)

Type	Nominal size	Medium air At 1 bar abs. and 20°C PA transp., Polysulphone	Tube size	Weight	
				Union	
				PVC-U	Malleable iron
DN	Nm ³ /h	Code	[kg]		
825 Float material PP (without magnet)	20	0.20 - 2.5	46	0.40	0.51
		0.30 - 4.0	47	0.40	0.51
		0.50 - 6.5	48	0.40	0.51
		0.75 - 10.0	49	0.39	0.50
	25	0.4 - 4.0	52	0.54	0.71
		0.5 - 6.5	53	0.53	0.70
		1.0 - 10.0	54	0.52	0.69
		1.5 - 16.0	55	0.51	0.68
	32	1.5 - 16.0	61	0.88	1.15
		2.0 - 25.0	62	0.86	1.13
		4.0 - 40.0	63	0.84	1.11
	40	2 - 25	67	1.10	1.42
		4 - 40	68	1.07	1.39
		5 - 50	69	1.06	1.38
50	4 - 40	71	1.17	2.04	
	6 - 64	72	1.14	2.01	
	10 - 100	73	1.09	1.95	
65	15 - 140	75	3.31	4.60	
	20 - 200	77	3.31	4.60	
831 Float material PVC-U (with magnet)	20	0.75 - 6.5	46	0.43	0.54
		1.00 - 10.0	47	0.43	0.54
		1.50 - 16.0	48	0.43	0.54
		2.00 - 25.0	49	0.43	0.53
	25	1.25 - 10	52	0.59	0.76
		1.50 - 16	53	0.58	0.75
		3.00 - 25	54	0.57	0.74
		4.00 - 40	55	0.55	0.73
	32	4 - 40	61	1.03	1.30
		6 - 64	62	1.01	1.28
		10 - 100	63	0.99	1.25
	40	5 - 60	67	1.30	1.62
10 - 100		68	1.27	1.59	
15 - 120		69	1.26	1.58	
50	10 - 100	71	1.69	2.57	
	15 - 160	72	1.66	2.54	
	20 - 250	73	1.61	2.49	
65	30 - 340	75	3.31	4.60	
	50 - 450	77	3.31	4.60	

To types 825/835:

Caution! With gaseous media the scaling alters according to operating pressure. Please state when ordering.

Special scales:

For other media and operating requirements differing from those given for standard versions, special scales are available. Please note the ordering information (see page 3).

Dimensions [mm]

Plastic union

Connection code				øD	7			33			
DN	G	LA*	O-ring		ød	LB		NPS	ød	LB	
Union material code					1	5	20	1			
20	G 1 1/4	350	28.0 x 3.5	53	25	394	392	388	3/4	26.7	394.0
25	G 1 1/2	350	33.0	60	32	400	396	392	1	33.6	400.0
32	G 2	350	46.0	74	40	408	400	397	1 1/4	42.2	408.0
40	G 2 1/4	350	50.4	83	50	418	406	403	1 1/2	48.3	418.0
50	G 2 3/4	350	68.0	103	63	432	414	411	2	60.3	432.0
65	G 3 1/2	350	85.0	122	75	444	420	420	2 1/2	73.5	444.4

Tube material PVDF = LA/LB -7 mm

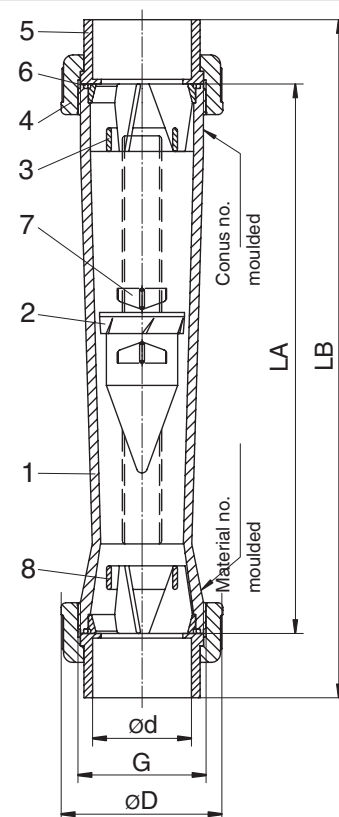

Metal and plastic union

Connection code				7R			
DN	G	LA*	O-ring	SW	Rp	L2	LD
Union material code				1, 6, 7			
20	G 1 1/4	350	28.0 x 3.5	50	Rp 3/4	16	395
25	G 1 1/2	350	33.0	55	Rp 1	17	402
32	G 2	350	46.0	66	Rp 1 1/4	19	410
40	G 2 1/4	350	50.4	74	Rp 1 1/2	20	414
50	G 2 3/4	350	68.0	90	Rp 2	24	420
65	G 3 1/2	350	85.0	110	Rp 2 1/2	30	430

Tube material PVDF = LA/LB -7 mm

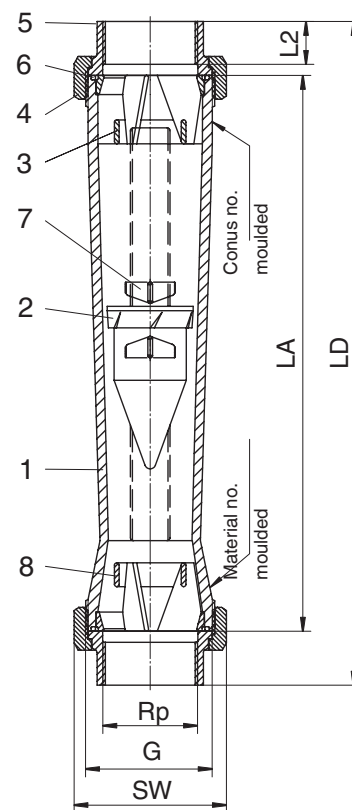

Dimensions [mm]

Plastic union																	
Connection code				øD	ød	s				78				71			
DN	G	LA*	O-ring			5		20		c		LC		c		LC	
Union material code						5	20	5	20	5	20	5	20	5	20		
20	G 1 1/4	350	28.0 x 3.5	53	25	2.3	1.9	39	462	-	-	-	-	-	-		
25	G 1 1/2	350	33.0	60	32	2.9	2.4	40	468	-	-	-	-	-	-		
32	G 2	350	46.0	74	40	3.7	2.4	41	474	-	-	-	-	-	-		
40	G 2 1/4	350	50.4	83	50	4.6	3.0	43	480	-	-	-	-	-	-		
50	G 2 3/4	350	68.0	103	63	5.8	3.0	43	486	-	-	-	-	-	-		
65	G 3 1/2	350	85.0	122	75	7.3	3.6	91	-	616	-	16	16	466	466		

Tube material PVDF = LA/LB -7 mm

Metal union															
Connection code				SW	øD	LC	c	17		37		59		60	
DN	G	LA*	O-ring					øD	s	øD	s	øD	s	øD	s
Union material code				41	1V, 2V	41, 1V, 2V									
20	G 1 1/4	350	28.0 x 3.5	50	53	426	34	23	1.5	-	-	19.05	1.65	26.9	1.6
25	G 1 1/2	350	33.0	55	60	429	35	29	1.5	25.0	1.2	25.40	1.65	33.7	2.0
32	G 2	350	46.0	66	74	432	36	35	1.5	33.7	1.2	-	-	42.4	2.0
40	G 2 1/4	350	50.4	74	83	432	36	41	1.5	38.0	1.2	38.10	1.65	48.3	2.0
50	G 2 3/4	350	68.0	90	103	432	36	53	1.5	51.0	1.2	50.80	1.65	60.3	2.0
65	G 3 1/2	350	85.0	110	122	433	36	70	2.0	63.5	1.6	63.50	1.65	76.1	2.0

Tube material PVDF = LA/LB -7 mm

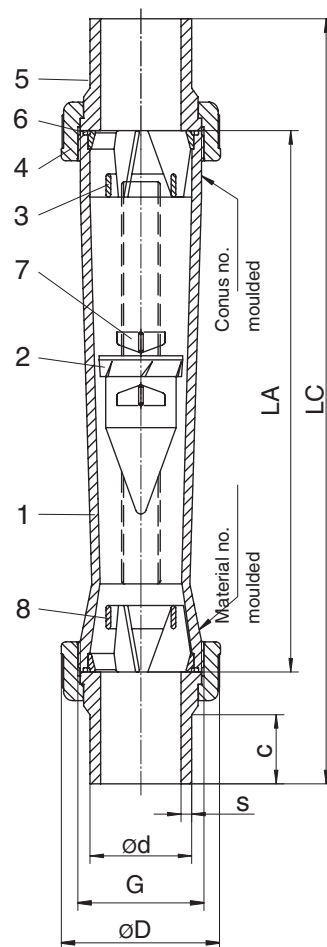

Designation		
Item		Pieces
1	Tube	1
2	Float	1
3	Upper float stop	1
4	Union nut	2
5	Union	2
6	O-ring (see table)	2
7	Flow indicator	2
8	Lower float stop	1

Overview GEMÜ 800

Union material code	1			5			6	7	20			41, 1V, 2V			
Connection code	7	7R	33	7	71	78	7R	7R	7	71	78	17	37	59	60
DN															
20	X	X	X	X	-	X	X	X	X	-	X	X	-	X	X
25	X	X	X	X	-	X	X	X	X	-	X	X	X	X	X
32	X	X	X	X	-	X	X	X	X	-	X	X	X	-	X
40	X	X	X	X	-	X	X	X	X	-	X	X	X	X	X
50	X	X	X	X	-	X	X	X	X	-	X	X	X	X	X
65	X	-	X	X	X	X	X	X	X	X	-	X	X	X	X

Accessories for variable area flowmeter series GEMÜ 800

To increase the versatility of the GEMÜ 800 flowmeter, numerous accessories have been developed which can be retrofitted onto the tube without modification.

The float, however, must be one containing a magnet, in order for these accessories to function.



GEMÜ 1250

Change-over contact
(Switching duty of magnetic switch 10 VA)

GEMÜ 1251

Limit switch (max.)
(Switching duty of magnetic switch 10 VA)

GEMÜ 1252

Limit switch (min.)
(Switching duty of magnetic switch 10 VA)



GEMÜ 1276

Digital display unit
Versions:
With or without switch points.



GEMÜ 1270

Instrument sensor for continuous flow readout (resistance 0 - 10 kΩ).

GEMÜ 1272

Instrument sensor for continuous flow readout via output signal 4-20 mA from an integrated 2-wire measuring transducer

Separate data sheets are available for the above accessories on request.

Other products from our product range:

- Plastic valves, pneumatically, electrically and manually operated.
- Metal valves, pneumatically, electrically and manually operated.

For further flowmeters, accessories and other products, please see our Product Range catalogue and Price List.
Contact GEMÜ.

GEMÜ® VALVES, MEASUREMENT
AND CONTROL SYSTEMS

