

SITRANS F flowmeters

SITRANS F M

Transmitter MAG 5000/6000

Overview



Transmitter MAG 5000/6000 compact version (left) and 19" insert version (right)

The MAG 5000 and 6000 are microprocessor-based transmitters engineered for high performance, easy installation, commissioning and maintenance. The transmitters evaluate the signals from the SITRANS F M sensors type MAG 1100, MAG 1100 F, MAG 3100 and MAG 5100 W.

Transmitter types:

- MAG 5000: Max. measuring error 0.5% of rate (incl. sensor)
- MAG 6000: Max. measuring error 0.25% of rate (incl. sensor, see also sensor specifications) and with additional features such as: Plug & Play insert bus modules; integrated batch functions.

Benefits

- Superior signal resolution for optimum turn down ratio
- Digital signal processing with many possibilities
- Automatic reading of SENSORPROM data for easy commissioning
- User configurable operation menu with password protection.
- 3 lines, 20 characters display in 11 languages.
- Flow rate in various units
- Totalizer for forward, reverse and net flow as well as additional information available
- Multiple functional outputs for process control, minimum configuration with analogue, pulse/frequency and relay output (status, flow direction, limits)
- Comprehensive self-diagnostic for error indication and error logging (see under SITRANS F M diagnostics)
- Batch control
- Custody transfer approval: PTB, OIML R75, R117, OIML R 49 and MI-001,
- MAG 6000 with add-on bus modules for HART, FOUNDATION Fieldbus H1, DeviceNet, MODBUS RTU/RS485, PROFIBUS PA and DP

Application

The SITRANS F M flowmeters are suitable for measuring the flow of almost all electrically conductive liquids, pastes and slurries. The main applications can be found in:

- Water and waste water
- Chemical and pharmaceutical industries
- Food & beverage industries
- Power generation and utility

Design

The transmitter is designed as either IP67 NEMA 4X enclosure for compact or wall mounting or 19" version as a 19" insert as a base to be used in:

- 19" rack systems
- Panel mounting IP65/NEMA 4
- Back of panel mounting IP20/NEMA 2
- Wall mounting IP66/NEMA 4

Several options on 19" versions are available such as:

- Transmitters mounted in safe area for Ex ATEX approved flow sensors (incl. barriers)
- Transmitters with electrode cleaning unit

Function

The MAG 5000/6000 are microprocessor-based transmitters with a built-in alphanumeric display in several languages. The transmitters evaluate the signals from the associated electro-magnetic sensors and also fulfil the task of a power supply unit which provides the magnet coils with a constant current.

Further information on connection, mode of operation and installation can be found in the data sheets for the sensors.

Displays and controls

Operation of the transmitter can be carried out using:

- Control and display unit
- HART communicator
- PC/laptop and SIMATIC PDM software via HART communication
- PC/laptop and SIMATIC PDM software using PROFIBUS or MODBUS communication

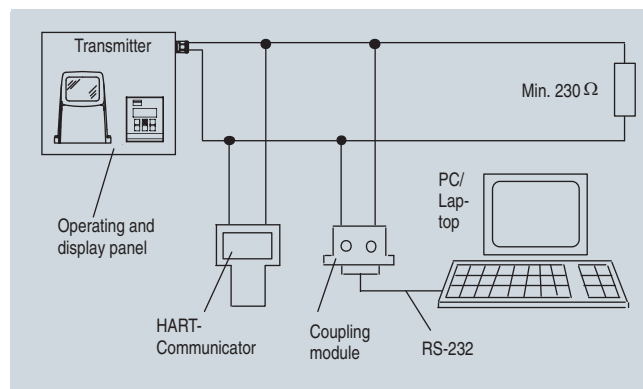

HART communication

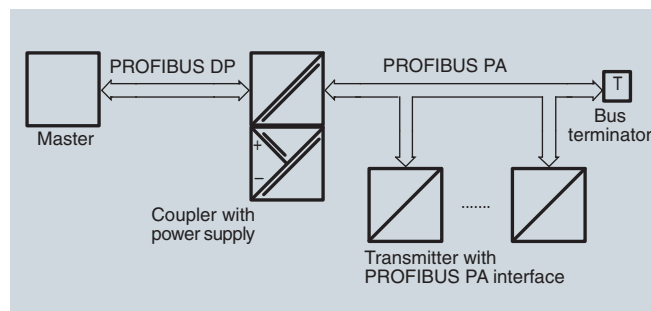

PROFIBUS PA communication

Transmitter MAG 5000/6000

Technical specifications

Mode of operation and design

Measuring principle	Electromagnetic with pulsed constant field
Empty pipe	Detection of empty pipe (special cable required in remote mounted installation)
Excitation frequency	Depend on sensor size
Electrode input impedance	$> 1 \times 10^{14} \Omega$

Input

Digital input	11 ... 30 V DC, $R_i = 4.4 \text{ K}\Omega$
• Activation time	50 ms
• Current	$I_{DC 11 \text{ V}} = 2.5 \text{ mA}$, $I_{DC 30 \text{ V}} = 7 \text{ mA}$

Output

Current output	
• Signal range	0 ... 20 mA or 4 ... 20 mA
• Load	$< 800 \Omega$
• Time constant	0.1 ... 30 s, adjustable

Digital output

Frequency	0 ... 10 kHz, 50% duty cycle (uni/bidirectional)
Pulse (active)	DC 24 V, 30 mA, $1 \text{ K}\Omega \leq R_i \leq 10 \text{ K}\Omega$, short-circuit-protected (power supplied from flowmeter)
Pulse (passive)	DC 3 ... 30 V, max. 110 mA, $200 \Omega \leq R_i \leq 10 \text{ K}\Omega$ (powered from connected equipment)
Time constant	0.1 ... 30 s, adjustable

Relay output

Time constant	Changeover relay, same as current output
Load	42 V AC/2 A, 24 V DC/1 A
Low flow cut off	0 ... 9.9% of maximum flow
Galvanic isolation	All inputs and outputs are galvanically isolated

Max. measuring error (incl. sensor and zero point)

MAG 5000	0.5% of rate
MAG 6000	0.25% of rate

Rated operation conditions

Ambient temperature	
• Operation	<ul style="list-style-type: none"> • Display version: -20 ... +50 °C (-4 ... +122 °F) • Blind version: -20 ... +60 °C (-4 ... +140 °F)
• Storage	-40 ... +70 °C (-40 ... +158 °F)

Mechanical load

Compact version	18 ... 1000 Hz, 3,17 G rms, sinusoidal in all directions to IEC 68-2-36
19" insert	1 ... 800 Hz, 1 G, sinusoidal in all directions to IEC 68-2-36

Degree of protection

Compact version	IP67/NEMA 4X to IEC 529 and DIN 40050 (1 mH ₂ O 30 min.)
19" insert	IP20/NEMA 2 to IEC 529 and DIN 40050

EMC performance

EN 61326-1 (all environments)
EN 61326-2-5

Display and keypad

Totalizer	Two eight-digit counters for forward, net or reverse flow
-----------	---

Display

Background illumination with alphanumeric text, 3 x 20 characters to indicate flow rate, totalized values, settings and faults; Reverse flow indicated by negative sign

Time constant

Time constant as current output time constant

Design

Enclosure material	
• Compact version	Fiber glass reinforced polyamide; optional (IP67 only): AISI 316 stainless steel
• 19"-insert	Standard 19" insert of aluminium/steel (DIN 41494), width: 21 TE, height: 3 HE
• Back of panel	IP20/NEMA 2; Aluminium
• Panel mounting	IP65/NEMA 4; ABS plastic
• Wall mounting	IP66/NEMA 4; ABS plastic

Dimensional drawings

Compact version	See dimensional drawings
19" insert	See dimensional drawings

Weight

Compact version	0.75 kg (2 lb)
19" insert	See dimensional drawings

Power supply

- 115 ... 230 V AC +10% -15%, 50 ... 60 Hz, 17 VA
- 11 ... 30 V DC or 11 ... 24 V AC

Power consumption

- 230 V AC: 17 VA
- 24 V AC : 9 W, $I_N = 380 \text{ mA}$, $I_{ST} = 8 \text{ A}$ (30 ms)
- 12 V DC : 11 W, $I_N = 920 \text{ mA}$, $I_{ST} = 4 \text{ A}$ (250 ms)

Certificates and approvals

CE, ULc general purpose, C-tick; CSA/FM Class 1, div 2	
Custody transfer approval (MAG 5000/6000 CT)	<ul style="list-style-type: none"> • PTB OIML R49 (cold water pattern approval); MI-001 • PTB and DANAK OIML R75 (hot water pattern approval) (MAG 6000 CT) • PTB and DANAK OIML R117 (cold water/milk, beer etc. pattern approval) (MAG 6000 CT)

Communication

Standard	
• MAG 5000	Without serial communication or HART as option
• MAG 6000	Prepared for client mounted add-on modules
Optional (MAG 6000 only)	HART, MODBUS RTU/RS485, FOUNDATION Fieldbus H1, DeviceNet, PROFIBUS PA, PROFIBUS DP as add-on modules
• MAG 5000/6000 CT	no communication moduls approved

SITRANS F flowmeters

SITRANS F M

Transmitter MAG 5000/6000

Safety barrier (e/ia)



Application	For use with MAG 5000/6000 19" and MAG 1100 Ex ATEX/MAG 3100 Ex ATEX		
Ex approval	MAG 1100 Ex [EEx e ia] IIB ATEX MAG 3100 Ex [EEx e ia] IIC ATEX		
Cable parameter	Group	Capacity in μF	Inductance in mH
• Electrode	IIC	≤ 4.1	≤ 80
	IIB	≤ 45	≤ 87
	IIA	≤ 45	≤ 87
Ambient temperature			
• During operation	-20 ... +50 °C (-4 ... +122 °F)		
• During storage	-20 ... +70 °C (-4 ... +158 °F)		
Enclosure			
• Material	Standard 19" insert in aluminium/steel (DIN 41494)		
• Width	21 TE (4.75")		
• Height	3 HE (5.25")		
• Rating	IP20 / NEMA 2 to EN 60529 and DIN 40050		
• Mechanical load	1 g, 1 ... 800 Hz sinusoidal in all directions to EN 60068-2-36		
EMC performance			
• Emission	EN 50081-1 (Light industry)		
• Immunity	EN 50082-2 (Industry)		

Electrode cleaning unit



Application	For use with transmitters MAG 5000 and 6000 19" to clean the electrodes on sensors MAG 1100 or MAG 3100		
	NB: Must not be used with intrinsically safe ATEX sensors NB: Not to be used with sensors with Hastelloy and Tantalum electrodes		
Cleaning voltage			
AC cleaning	60 V AC		
DC cleaning	30 V DC		
Cleaning period	60 s + 60 s pause period		
Relay			
• Load	42 V/2 A		
Operation	Switch relay activated when cleaning is in progress		
• Automatic	Yes		
• Manual	No		
Indicator lamps	LEDs: "ON" and "CLEANING"		
Supply voltage and power consumption	115 ... 230 V AC, +10% ... -15%, 50 ... 60 Hz, 7 VA cleaning, 5 VA stand by 11 ... 30 V DC / 11 ... 24 V AC, 50 ... 60 Hz, 7 VA cleaning, 5 VA stand by		
Ambient temperature			
• During operation	-20 ... +50 °C (-4 ... +122 °F)		
• During storage	-20 ... +70 °C (-4 ... +158 °F)		
Enclosure			
• Material	Standard 19" insert in aluminium/steel (DIN 41494)		
• Width	21 TE (4.75")		
• Height	3 HE (5.25")		
• Rating	IP20 / NEMA 2 to EN 60529 and DIN 40050		
• Mechanical load	1 g, 1 ... 800 Hz sinusoidal in all directions to EN 60068-2-36		

Cleaning unit

The Siemens cleaning unit can be used with MAG 5000 or 6000 in 19" insert version.

The cleaning unit can be used in applications where the liner and subsequently the electrodes may be coated with deposits. If the coating is electrically insulating, the electrode signal will be reduced. If the coating is electrically inductive, the electrode signal will be partly short-circuited and in both cases the accuracy of the meter will decrease (dependent on coating type and thickness).

Note:

The cleaning unit cannot be used for inflammable or explosive media!

Mode of operation

The cleaning unit cleans the electrodes electro-chemically by applying a voltage to the electrodes for approx. 60 seconds. While cleaning, the transmitter stores and holds the latest measured flow reading on the display and also the signal outputs. After an additional pausing period of 60 seconds the flowmeter resumes normal measurement and the cleaning is now completed.

The relay in the transmitter activates the cleaning cycle. In the relay output menu (under cleaning) the cleaning interval can be set between 1 hour and 24 hours.

Cleaning should only take place with liquid in the pipe. This can be detected via the empty pipe function. It is therefore recommended to select "empty pipe detection" ON when using the cleaning.

The cleaning sequence can also be controlled manually through the electrical input of the transmitter. Before this is done, ensure that the measuring pipe is full.

AC cleaning

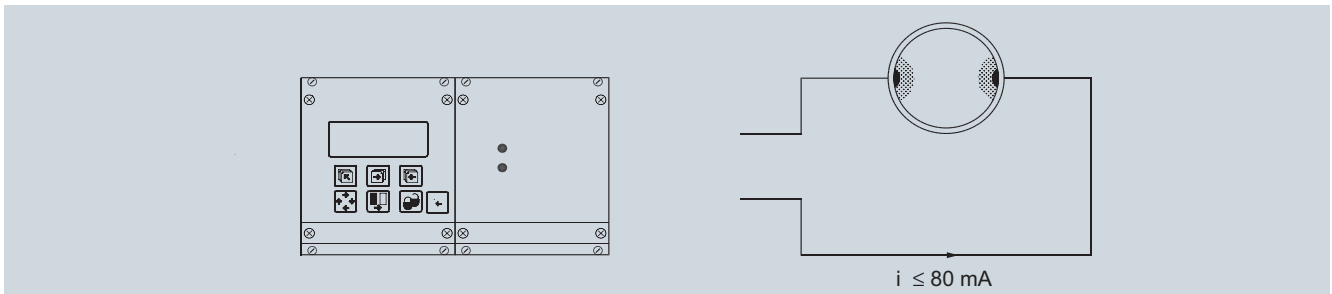

AC-cleaning is used to remove fatty deposits on the electrodes. These fatty deposits are seen in waste water applications, in abattoirs and water applications with oil residuals. During the cleaning process, the surface of the electrodes get warmer, which tends to soften grease particles and the gas bubbles generated mechanically lift deposits away from the surface of the electrodes.

Note:

Do not use AC-cleaning on sensors with Tantalum or Hastelloy electrodes.

DC cleaning

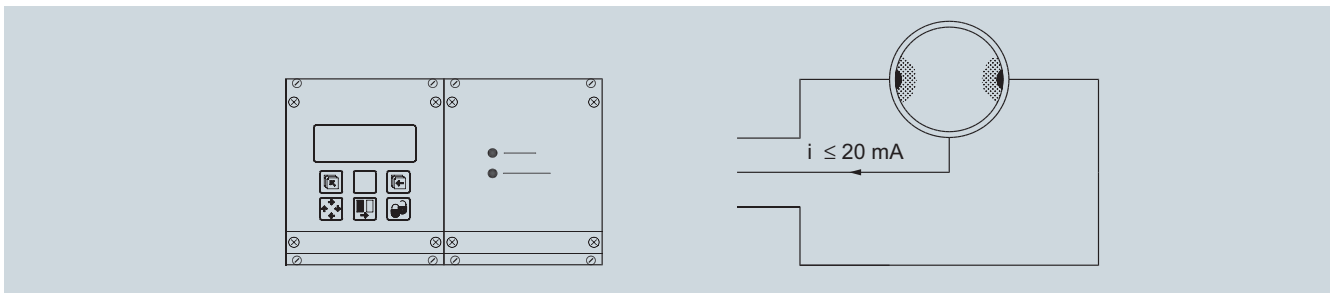

DC-cleaning is used to eliminate electrically conductive deposits in the measuring pipe influencing the measuring accuracy.

Particularly in district heating applications an electrically conductive deposit (magnetite) may occur and short-circuit the electrode signal. In this case the accuracy of the meter decreases and the signal/noise conditions of the meter become inferior. The problem only arises if the conductivity of the water is less than approx. 250 $\mu\text{S}/\text{cm}$.

During DC-cleaning electrolysis takes place where the flow of electrons removes the particle deposits from the electrode area.

Note:

Do not use DC-cleaning on sensors with Tantalum or Hastelloy electrodes.





SITRANS F flowmeters

SITRANS F M



Transmitter MAG 5000/6000

Selection and Ordering Data









Transmitter MAG 5000

Description	Order No.	
Transmitter MAG 5000 Blind for compact and wall mounting; IP67/NEMA 4X, fibre-glass reinforced polyamide <ul style="list-style-type: none"> • 11 ... 30 V DC / 11 ... 24 V AC • 115/230 V AC, 50/60 Hz 	7ME6910-1AA30-0AA0 7ME6910-1AA10-0AA0	
Transmitter MAG 5000 Display for compact and wall mounting; IP67/NEMA 4X, fibre-glass reinforced polyamide <ul style="list-style-type: none"> • 11 ... 30 V DC / 11 ... 24 V AC • 115/230 V AC, 50/60 Hz • 115/230 V AC, 50/60 Hz, with HART 	▶ 7ME6910-1AA30-1AA0 ▶ 7ME6910-1AA10-1AA0 7ME6910-1AA10-1BA0	
Transmitter MAG 5000 CT for compact and wall mounting, approved for custody transfer; IP67/NEMA 4X, fibre-glass reinforced polyamide <ul style="list-style-type: none"> • 11 ... 30 V DC / 11 ... 24 V AC • 115/230 V AC, 50/60 Hz 	7ME6910-1AA30-1AB0 7ME6910-1AA10-1AB0	
Transmitter MAG 5000 for 19" rack and wall mounting <ul style="list-style-type: none"> • 11 ... 30 V DC / 11 ... 24 V AC • 115/230 V AC, 50/60 Hz 	7ME6910-2CA30-1AA0 7ME6910-2CA10-1AA0	

Transmitter MAG 6000

Description	Order No.	
Transmitter MAG 6000 Blind for compact and wall mounting; IP67/NEMA 4X, fibre-glass reinforced polyamide <ul style="list-style-type: none"> • 11 ... 30 V DC / 11 ... 24 V AC • 115/230 V AC, 50/60 Hz 	7ME6920-1AA30-0AA0 7ME6920-1AA10-0AA0	
Transmitter MAG 6000 for compact and wall mounting; <ul style="list-style-type: none"> • 11 ... 30 V DC / 11 ... 24 V AC • 115/230 V AC, 50/60 Hz 	7ME6920-1AA30-1AA0 7ME6920-1AA10-1AA0	
IP67/NEMA 4X, AISI 316 stainless steel (only for sensor with SS terminal box) <ul style="list-style-type: none"> • 11 ... 30 V DC / 11 ... 24 V AC • 115/230 V AC, 50/60 Hz 	7ME6920-1QA30-1AA0 7ME6920-1QA10-1AA0	

▶ Available ex stock

Description	Order No.	
Transmitter MAG 6000 CT for compact and wall mounting, approved for custody transfer (no communication moduls possible); IP67/NEMA 4X, fibre-glass reinforced polyamide <ul style="list-style-type: none"> • 11 ... 30 V DC / 11 ... 24 V AC • 115/230 V AC, 50/60 Hz 	7ME6920-1AA30-1AB0 7ME6920-1AA10-1AB0	
Transmitter MAG 6000 SV for compact and wall mounting; special excitation 44 Hz settings for Batch application DN ≤ 25/1" IP67/NEMA 4X, fibre-glass reinforced polyamide <ul style="list-style-type: none"> • 11 ... 30 V DC / 11 ... 24 V AC • 115/230 V AC, 50/60 Hz 	7ME6920-1AB30-1AA0 7ME6920-1AB10-1AA0	
Transmitter MAG 6000 for 19" rack and wall mounting <ul style="list-style-type: none"> • 11 ... 30 V DC / 11 ... 24 V AC • 115/230 V AC, 50/60 Hz 	7ME6920-2CA30-1AA0 7ME6920-2CA10-1AA0	
Transmitter MAG 6000 SV for 19" rack and wall mounting; special excitation 44 Hz settings for Batch application DN ≤ 25/1" <ul style="list-style-type: none"> • 11 ... 30 V DC / 11 ... 24 V AC • 115/230 V AC, 50/60 Hz 	7ME6920-2CB30-1AA0 7ME6920-2CB10-1AA0	
MAG 6000 with IP66/NEMA 4X enclosure; 115/230 V AC, 50/60 Hz	7ME6920-2EA10-1AA0	
MAG 6000 with electrode cleaning unit, complete mounted with IP66/NEMA 4X mounting enclosure <ul style="list-style-type: none"> • 11 ... 30 V DC / 11 ... 24 V AC • 115/230 V AC, 50/60 Hz 	7ME6920-2PA30-1AA0 7ME6920-2PA10-1AA0	
MAG 6000 with safety barrier for ATEX 2G D approved sensors, complete mounted with IP66/NEMA 4X wall mounting enclosure, ATEX, 115/230 V AC, 50/60 Hz <ul style="list-style-type: none"> • For ATEX 2G D sensors 	7ME6920-2MA11-1AA0	
MAG 6000 SV, 19" insert, in IP66/NEMA 4X, ABS plastic enclosure, excitation frequency 44 Hz for Batch application DN ≤ 25/1", 11 ... 30 V DC, 11 ... 24 V AC, 50/60 Hz	7ME6920-2EB30-1AA0	

SITRANS F flowmeters

SITRANS F M

Transmitter MAG 5000/6000

Communication modules for MAG 6000

Description	Order No.
HART (not for MAG 6000 I)	▶ FDK-085U0226
MODBUS RTU/RS485	▶ FDK-085U0234
PROFIBUS PA Profile 3	▶ FDK-085U0236
PROFIBUS DP Profile 3	▶ FDK-085U0237
DeviceNet	▶ FDK-085U0229
FOUNDATION Fieldbus H1	▶ A5E02054250



Accessories for MAG 5000 and MAG 6000

Description	Order No.
Wall mounting unit for IP67/NEMA 4X version, wall bracket, terminal box in polyamide	
• 4 x M20 cable glands	▶ FDK-085U1018
• 4 x ½" NPT cable glands	▶ FDK-085U1053
Cable for standard electrode or coil, 3 x 1.5 mm ² / 18 gage with shield PVC	
• 10 m (33 ft)	▶ FDK-083F0121
• 20 m (65 ft)	▶ FDK-083F0210
• 40 m (130 ft)	▶ FDK-083F0211
• 60 m (200 ft)	▶ FDK-083F0212
• 100 m (330 ft)	FDK-083F0213
• 150 m (500 ft)	FDK-083F3052
• 200 m (650 ft)	FDK-083F3053
• 500 m (1650 ft)	FDK-083F3054
Electrode cable for empty pipe or low conductivity, double shielded, 3 x 0.25 mm ²	
• 10 m (33 ft)	FDK-083F3020^{D)}
• 20 m (65 ft)	▶ FDK-083F3095^{D)}
• 40 m (131 ft)	FDK-083F3094^{D)}
• 60 m (200 ft)	FDK-083F3093^{D)}
• 100 m (330 ft)	FDK-083F3092^{D)}
• 150 m (500 ft)	FDK-083F3056^{D)}
• 200 m (650 ft)	FDK-083F3057^{D)}
• 500 m (1650 ft)	FDK-083F3058^{D)}
Cable kit with standard coil cable, 3 x 1.5 mm ² /18 gage with shield PVC and electrode cable double shielded, 3 x 0.25 mm ²	
• 10 m (33 ft)	A5E01181647^{F)}
• 20 m (65 ft)	A5E01181656^{F)}
• 40 m (130 ft)	A5E01181686^{F)}
• 60 m (200 ft)	A5E01181689^{F)}
• 100 m (330 ft)	A5E01181691^{F)}
• 150 m (500 ft)	A5E01181699^{F)}
• 200 m (650 ft)	A5E01181703^{F)}
• 500 m (1640 ft)	A5E01181705^{F)}

Description	Order No.
Cable glands, for above cable, 2 pcs.	
• M20	A5E00822490
• ½" NPT	A5E00822501
Sealing screws for sensor/transmitter, 2 pcs	FDK-085U0221
Terminal box, in polyamide, inclusive lid	
• M20	▶ FDK-085U1050
• ½" NPT	FDK-085U1052
Terminal box lid, in polyamid	FDK-085U1003
Terminal box for MAG 6000, in stainless steel, inclusive lid	
• M20	A5E00836867
• ½" NPT	A5E00836868
Terminal box (3A) for MAG 1100 Food in polyamide, inclusive lid	
• M20	A5E00822478
• ½" NPT	A5E00822479
Potting kit for terminal box of MAG sensors for IP68/NEMA 6P (not ATEX)	▶ FDK-085U0220
19" cleaning unit for electrode cleaning (21TE) incl. back plate	
• 11 ... 30 V DC / 11 ... 24 V AC	FDK-083F5039
• 115 ... 230 V AC, 50/60 Hz	FDK-083F5036
19" safety barrier (21 TE) [EE e ia] IIC for MAG 1100 ATEX and MAG 3100 ATEX, incl. back plate	FDK-083F5034
Panel mounting enclosure for 19" insert (21 TE); IP65/NEMA 4 enclosure in ABS plastic for front panel mounting	FDK-083F5030
Panel mounting enclosure for 19" insert (42 TE); IP65/NEMA 4 enclosure in ABS plastic for front panel mounting	FDK-083F5031
Back of panel mounting enclosure for 19" insert (21 TE); IP20/NEMA 2 enclosure in aluminium	FDK-083F5032

▶ Available ex stock



D) Subject to export regulations AL: N, ECCN: EAR99H.

F) Subject to export regulations AL: 91999, ECCN: N.

SITRANS F flowmeters

SITRANS F M





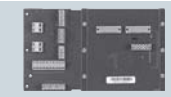
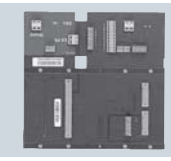

Transmitter MAG 5000/6000

Description	Order No.	
Back of panel mounting enclosure for 19" insert (42 TE); IP20/NEMA 2 enclosure in aluminium	FDK-083F5033	
IP66/NEMA 4, wall mounting enclosure for 19" inserts (without backplates)	FDK-083F5037	
<ul style="list-style-type: none"> • 21 TE 		
<ul style="list-style-type: none"> • 42 TE 	▶ FDK-083F5038	
Front cover (7TE)	FDK-083F4525	
▶ Available ex stock		

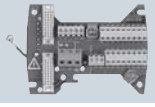
Back plates (if wall enclosure IP66 is used as part)

Description	Order No.	
Wall unit enclosure IP66, 12 ... 24 V, 115 ... 230 V		
<ul style="list-style-type: none"> • Transmitter 	FDK-083F4121	
<ul style="list-style-type: none"> • Transmitter ia/e and safety barrier 	FDK-083F4122	
<ul style="list-style-type: none"> • Transmitter ia/ib and safety barrier (only for sensors produced before October 2007) 	FDK-083F4120	
<ul style="list-style-type: none"> • Transmitter and cleaning unit 	FDK-083F4124	

Spare parts

Description	Order No.	
Connection plate		
<ul style="list-style-type: none"> • 12 ... 24 V • 115 ... 230 V 	FDK-083F4149 FDK-083F4148	
19" enclosure, 12 ... 24 V, 115 ... 230 V		
<ul style="list-style-type: none"> • Connection plate for standard 19" transmitter 	FDK-083F4117	
<ul style="list-style-type: none"> • Connection plate for transmitter ia and safety barrier 	FDK-083F4118	
<ul style="list-style-type: none"> • Connection plate for transmitter ia/ib and safety barrier (only for sensors produced before October 2007) 	FDK-083F4119	
<ul style="list-style-type: none"> • Connection plate for transmitter and cleaning unit 	FDK-083F4123	
SENSORPROM memory unit (Sensor code and serial numbers must be specified on order)		
<ul style="list-style-type: none"> • 2 kB (for MAG 5000/6000/ MAG 6000 I) 	FDK-085U1005	
<ul style="list-style-type: none"> • 250 B (for MAG 2500/3000) 	FDK-085U1008	
Display unit for MAG 5000/6000		
<ul style="list-style-type: none"> • black neutral front 	FDK-085U1038	
<ul style="list-style-type: none"> • Siemens front 	FDK-085U1039	

Sun Shields for MAG 5000/6000 transmitters

Description	Order No.	
Sun shield for remote MAG 5000/6000 transmitters	A5E01209496	
Sun Shield for compact MAG 5000/6000 transmitters on MAG 3100 (DN 15 ... 2000 (1/2" ... 78") or MAG 5100 (DN 150 ... 1200 (6" ... 48"))	A5E01209500	

Dimensional drawings

Transmitter IP67/NEMA 4X compact polyamide

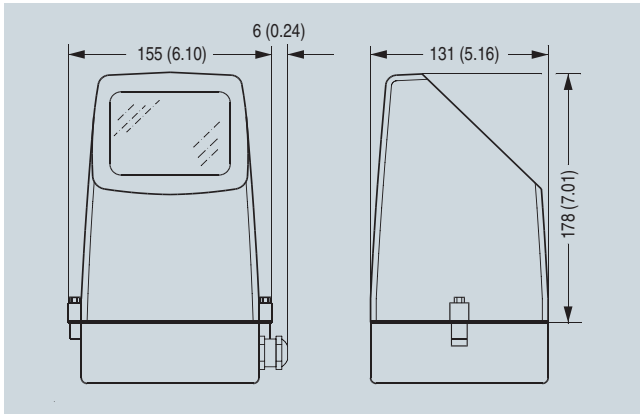

Transmitter compact mounted

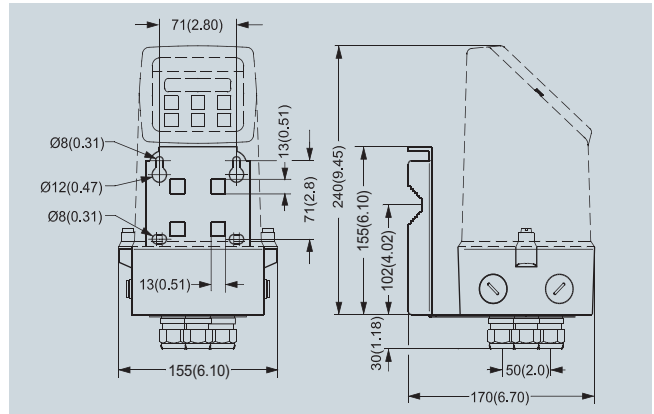

Transmitter wall mounted

Transmitter, 19" IP20/ NEMA 2 standard unit

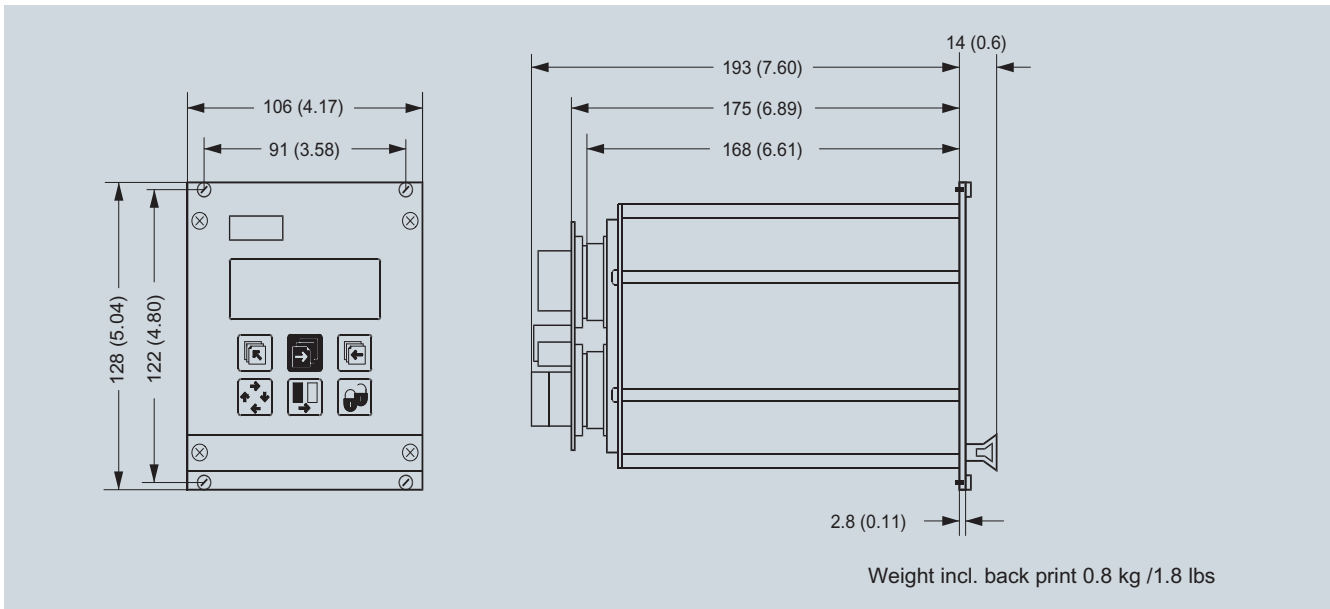

SITRANS F flowmeters

SITRANS F M

Transmitter MAG 5000/6000

Transmitter, wall mounting IP66/NEMA 4, 21 TE

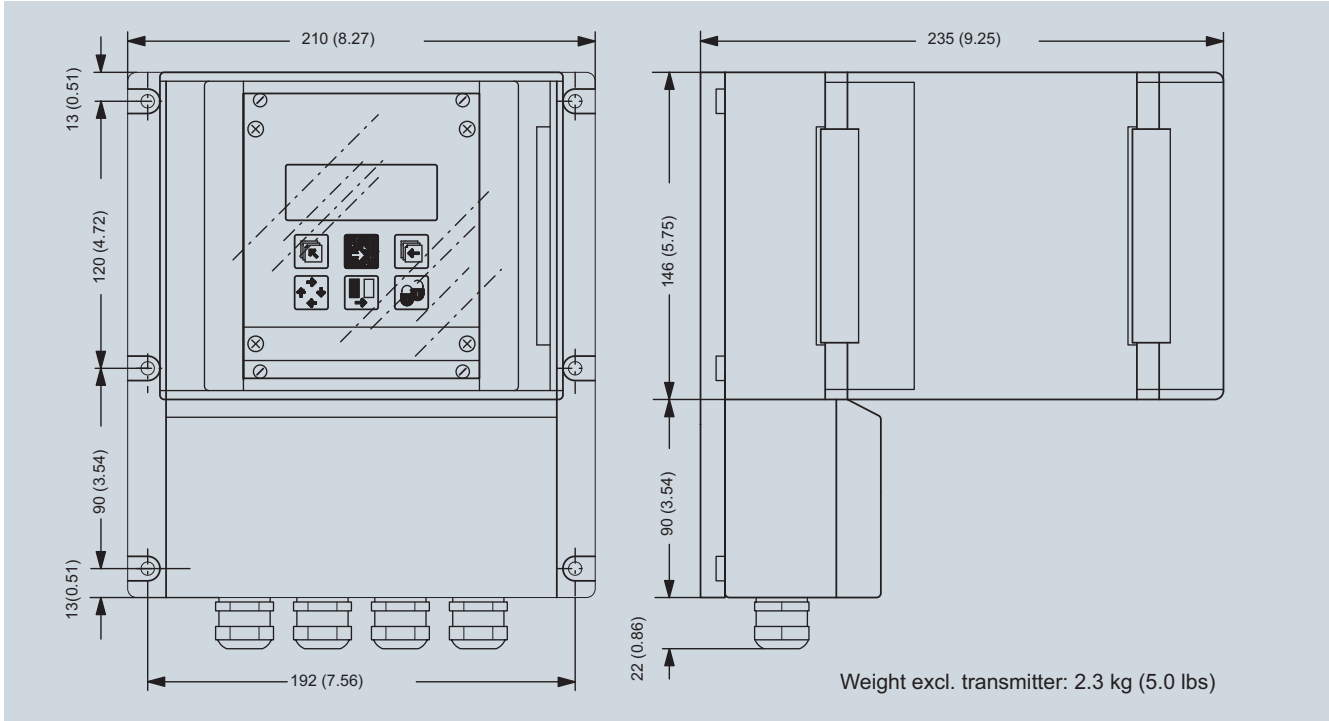

4

Transmitter, wall mounting IP66/NEMA 4, 42 TE

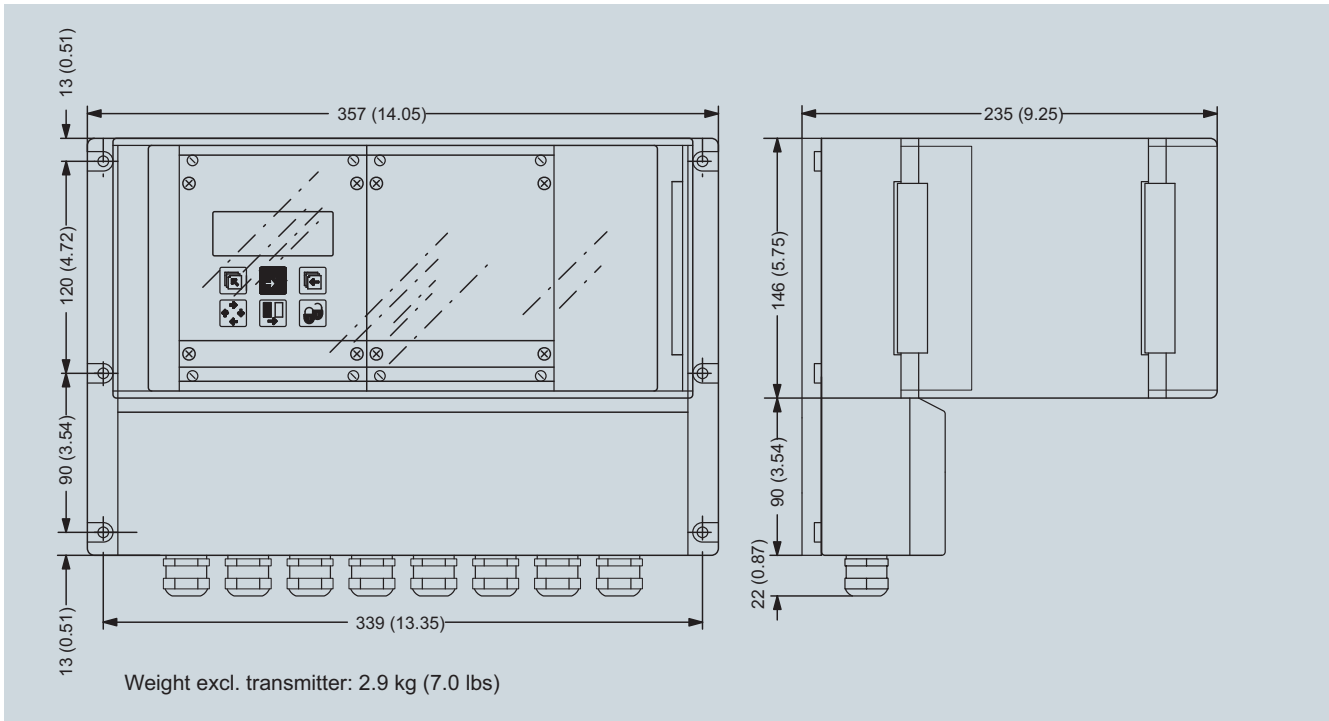

SITRANS F flowmeters

SITRANS F M

Transmitter MAG 5000/6000

Transmitter, panel front IP65/NEMA 4, 21 TE

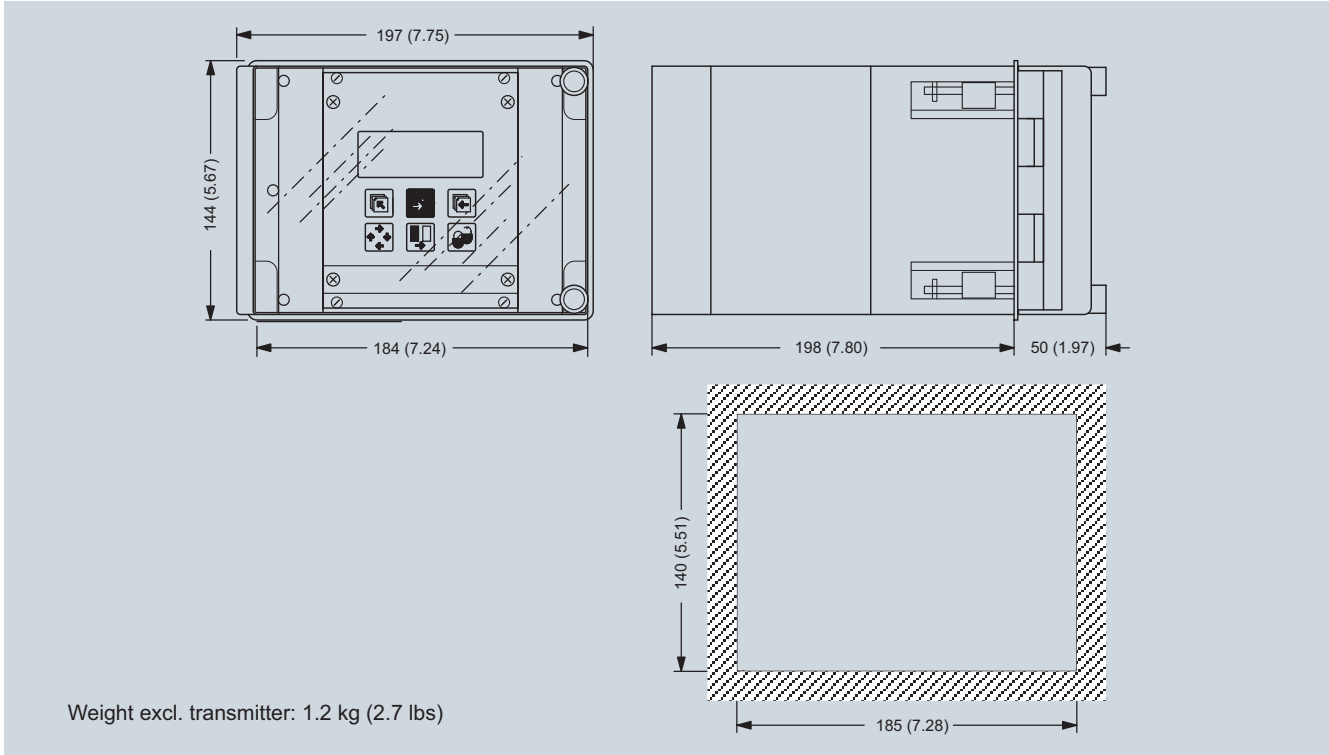

4

Transmitter, panel front IP65/NEMA 4, 42 TE

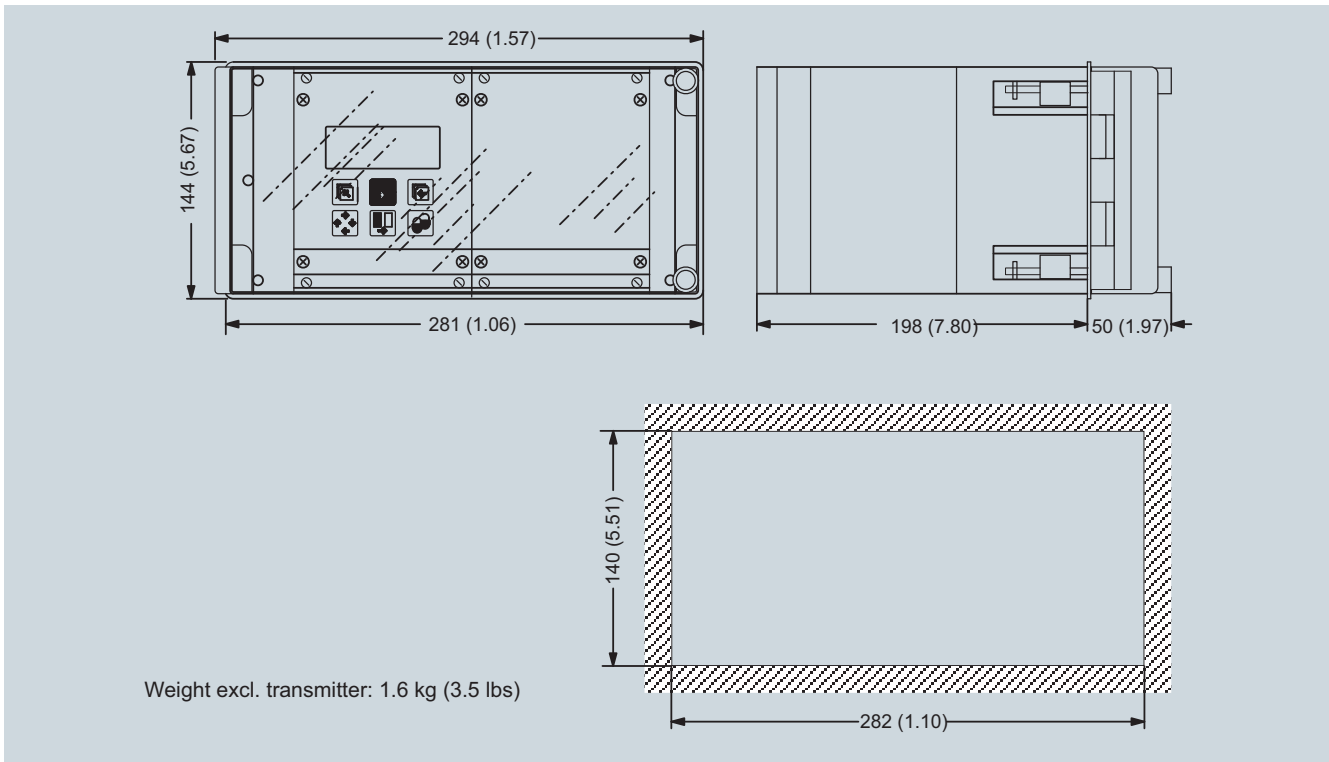

SITRANS F flowmeters

SITRANS F M

Transmitter MAG 5000/6000

Transmitter, back of panel IP20/NEMA 2, 21 TE

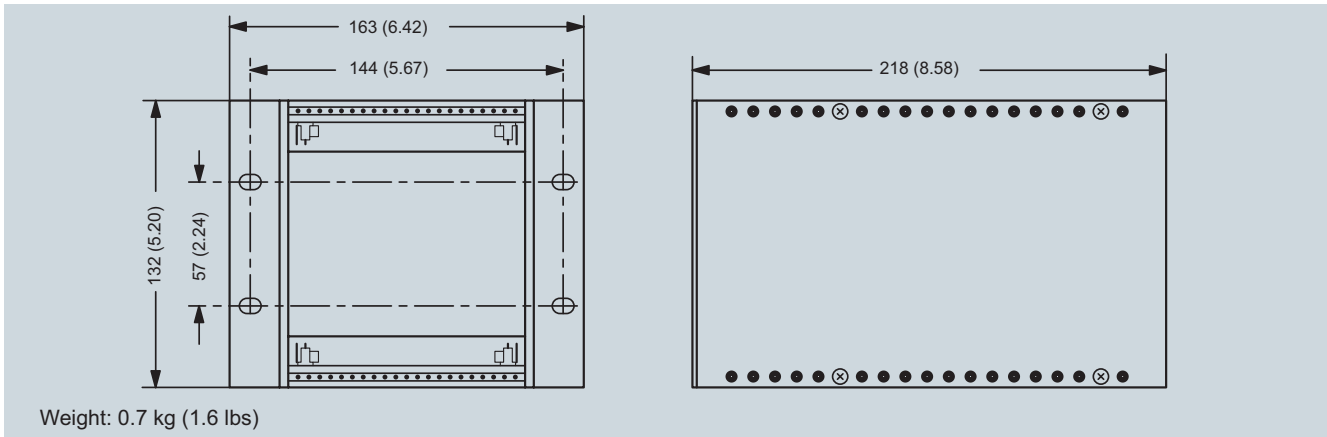

4

Transmitter, back of panel IP20/NEMA 2, 42 TE

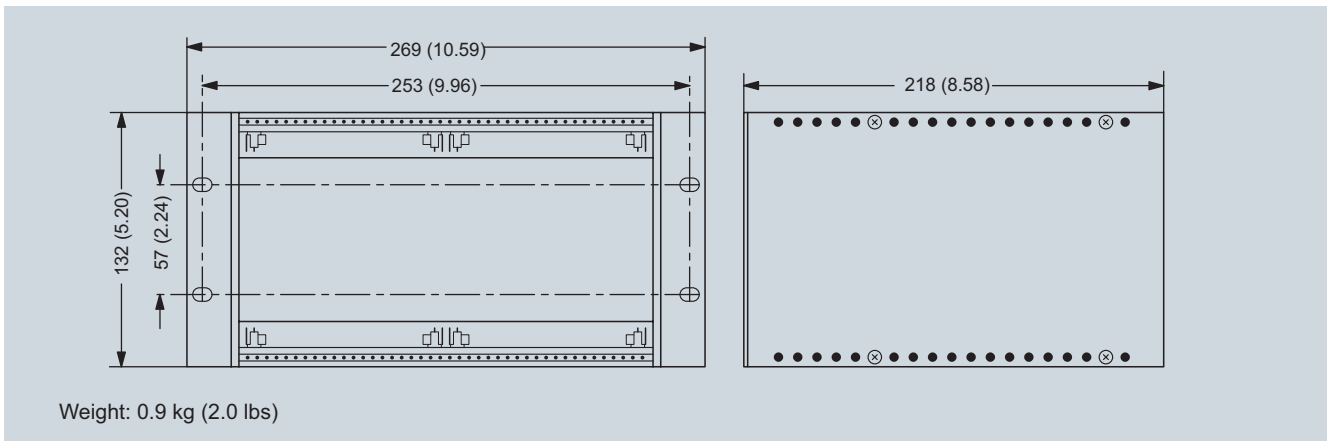

Schematics**Electrical connection**Grounding

PE must be connected due to safety class 1 power supply.

Mechanical counters

When mounting a mechanical counter to terminals 57 and 58 (active output), a 1000 μ F capacitor must be connected to the terminals 56 and 58. Capacitor + is connected to terminal 56 and capacitor - to terminal 58.

Output cables

If the output cable length is long in noisy environment, we recommend to use screened cable.

