

Series 8700 Magnetic Flowmeter Systems

THE 8700 SERIES...

- *Model 8712 C/U Transmitter - Easiest to use local operator interface and works with any manufacturer's flowtubes*
- *Model 8712H/8707 High-Signal System - Pulsed dc solutions for the most demanding flow measurement applications*
- *Model 8732C Transmitter - Compact, integral-mount design eliminates wiring errors between flowtube and transmitter*
- *Model 8705 - Fully welded flowtube for maximum protection (standard ISO lay length)*
- *Model 8711 - Easy to install flowtube for maximum flexibility from provided alignment rings*



Content

Model 8712C/U/H Magnetic Flowmeter Transmitters	page 4
Model 8732C Magnetic Flowmeter Transmitter Specifications	page 7
Model 8705 Flanged and 8707 High-Signal Flanged Flowtubes Specifications	page 10
Model 8711 Wafer Flowtube Specifications.	page 13
Model 8714D Reference Calibration Standard Specifications.	page 15
Hazardous Location Certifications.	page 16
Dimensional Drawings.	page 18
Magnetic Flowmeter Sizing.	page 29
Material Selection	page 31
Ordering Information	page 32
Configuration Data Sheet	page 42

Series 8700

Series 8700 System Overview

Model 8712C/U

While the Model 8712C transmitter operates with all Rosemount magnetic flowmeter flowtubes, the Model 8712U, a universal transmitter, operates on other magnetic flowmeter manufacturer's flowtubes. With the Model 8712U, other manufacturer's flowtubes can benefit from the 8712's advantages such as zero stability, better repeatability, and ease of use.

Series 8712 transmitters have an optional backlit 2 line by 20 character LOI that performs all the functions necessary for setting up a transmitter and flowtube system. The LOI is designed for fast, easy configuration with keypad access to transmitter parameters.



Sanitary Construction

The Model 8705 is available in a 3-A approved sanitary configuration. To ensure a crevice-free interface, the adapter flanges are designed to attach to a magnetic flowtube of smaller diameter than the process piping. The adapters provided are polished internally and externally. Each adapter is attached to the flowtube with the appropriate stainless steel bolts for easy assembly.

Model 8732C

The Model 8732C transmitter has an explosion proof housing and full RFI/EMI protection that is ideal for harsh environment installations where moisture and contaminant in filtration are possible. With an optional, backlit 2 line by 16 character local operator interface, the transmitter can be configured by optical switches with the covers on to simplify adjustments in hazardous environments.



Model 8714D

The Model 8714D Calibration Standard attaches to a Model 8712C/U, Model 8732, or Model 8742C transmitter's flowtube connections to ensure traceability to NIST standards and long-term accuracy of the flowmeter system. Model 8714D is not compatible with Model 8712H.

Product Data Sheet

00813-0100-4727, Rev HA
January 2002

Series 8700

Model 8705/ 8707

The housing for the Model 8705 and Model 8707 flowtube is fabricated from carbon steel and is fully welded to provide a hermetic seal that protects against moisture and other contaminants. The sealed housing ensures maximum flowtube reliability by protecting all internal components and wiring from the most hostile environments.



Model 8711

The flangeless design of the Model 8711 wafer flowtube makes it an economical, compact, and lightweight alternative to flanged magnetic flowmeters. Alignment rings, provided with every Model 8711 flowtube, center the flowtube in the process line and makes the installation easier.



High-Signal Magmeter System

The Model 8707 High-Signal Flowtube, used in conjunction with the Model 8712H High-Signal Transmitter, forms the Rosemount High-Signal Magnetic Flowmeter System. This system provides stable flow measurement in the most difficult high-noise applications while maintaining the benefits of dc technology. The increased signal strength of the Rosemount® high-signal system is made possible through a combination of flowtube coil design that incorporates the most advance materials and an extremely efficient and innovative coil drive circuit. The increased signal strength of the Rosemount high-signal system, coupled with advanced signal processing and superior filtering techniques, provides the solution to demanding flow measurement applications.

Model 8712C/U/H Magnetic Flowmeter Transmitters

Functional Specifications

Flowtube Compatibility

Model 8712C is compatible with all Rosemount flowtubes: Models 8705, 8707, and 8711. The Model 8712U is also compatible with AC and DC powered flowtubes of other manufacturers. The Model 8712H is only compatible with Model 8707 High-Signal flowtube.

Flowtube Coil Resistance

Model 8712C: 25 Ω maximum
Model 8712U: 350 Ω maximum
Model 8712H: 10 Ω maximum

Flow Rate Range

Capable of processing signals from fluids that are traveling between 0.04 and 30 ft/s (0.01 to 10 m/s) for both forward and reverse flow in all flowtube sizes. Full scale continuously adjustable between -30 and 30 ft/s (-10 to 10 m/s).

Conductivity Limits

Process liquid must have a conductivity of 5 microsiemens/cm (5 micromhos/cm) or greater for Model 8712C/U. Process liquid must have a conductivity of 50 microsiemens/cm (50 micromhos/cm) for the Model 8712H. Excludes the effect of interconnecting cable length in remote mount transmitter installations.

Power Supply

Model 8712C/U: 115 or 230 V ac ±10%, 50–60 Hz or 10–30 V dc
Model 8712H: 115 V ac ±10%, 50–60 Hz

DC Load Limitations (Analog Output)

Maximum loop resistance is determined by the voltage level of the external power supply, as described by:

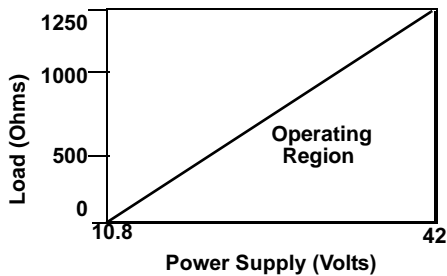

$$R_{\max} = 41.7(V_{ps} - 10.8)$$

V_{ps} = Power Supply Voltage (Volts)
 R_{\max} = Maximum Loop Resistance (Ohms)

NOTE

HART Communication requires a minimum loop resistance of 250 ohms.

Supply Current Requirements

Units powered by 10-30 V dc power supply may draw up to 2 amp of current.

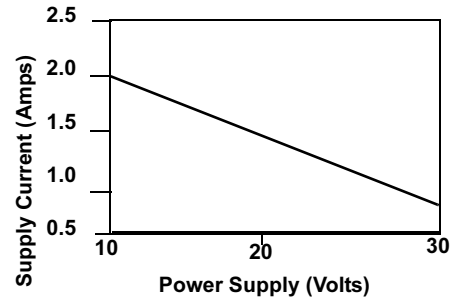

$$I = 20/V$$

I = Supply current requirement (Amps)
 V = Power supply voltage (Volts)

Installation Coordination

Installation (overvoltage) Category II

Power Consumption

Model 8712C/U: 20 watts maximum
Model 8712H: 300 watts maximum

Ambient Temperature Limits

Operating

Model 8712C/U: -20 to 140 °F (-29 to 60 °C) with local operator interface
-30 to 150 °F (-34 to 66 °C) without local operator interface
Model 8712H: -20 to 130 °F (-29 to 54 °C) with or without local operator interface

Storage

-22 to 176 °F (-30 to 80 °C)

Humidity Limits

0–100% RH at 120 °F (49 °C), decreases linearly to 10% RH at 130 °F (54 °C)

Enclosure Ratings

NEMA 4X, CSA Enclosure Type 4X

Product Data Sheet

00813-0100-4727, Rev HA

January 2002

Series 8700

Output Signals

Analog Output Adjustment

4–20 mA, jumper-selectable as internally or externally powered 5 to 24 V dc; 0 to 1000 Ω load.

Engineering units—lower and upper range values are user-selectable.

Output automatically scaled to provide 4 mA at lower range value and 20 mA at upper range value. Full scale continuously adjustable between -30 and 30 ft/s (-10 to 10 m/sec), 1 ft/s (0.3 m/s) minimum span.

HART Communications, digital flow signal, superimposed on 4–20 mA signal, available for control system interface. 250 Ω required for HART communications.

Scalable Frequency Adjustment

0-1000 Hz, externally powered at 5 to 24 V dc, translator switch closure up to 5.75 w. Pulse value can be set to equal desired volume in selected engineering units. Pulse width adjustable from 0.5 to 100 m/s. Local operator interface automatically calculates and displays maximum allowable output frequency.

Auxiliary Output Function

Externally powered at 5 to 24 V dc, transistor switch closure up to 3 W to indicate either:

Reverse Flow: Activates switch closure output when reverse flow is detected. The reverse flow rate is displayed.

Zero Flow: Activates switch closure output when flow goes to 0 ft/s.

Positive Zero Return

Forces outputs of the transmitter to the zero flow rate signal level. Activated by applying a contact closure.

Software Lockout

Security lockout jumper on the electronics board can be set to deactivate all LOI and HART-based communicator functions to protect configuration variables from unwanted or accidental change.

Output Testing

Analog Output Test

Transmitter may be commanded to supply a specified current between 3.75 and 23.25 mA

Pulse Output Test

Transmitter may be commanded to supply a specified frequency between 1 and 1000 Hz

Turn-on Time

30 minutes to rated accuracy from power up,
5 seconds from power interruption

Start-up Time

0.2 seconds from zero flow

Low Flow Cutoff

Adjustable between 0.04 and 1 ft/s (0.01 and 0.3 m/s). Below selected value, output is driven to the zero flow rate signal level.

Overrange Capability

Signal output will remain linear until 110% of upper range value or 33 ft/s. The signal output will remain constant above these values. Out of range message displayed on LOI and the HART Communicator.

Damping

Adjustable between 0.2 and 256 seconds

Flowtube Compensation

Rosemount flowtubes are flow-calibrated and assigned a calibration factor at the factory. The calibration factor is entered into the transmitter, enabling interchangeability of flowtubes without calculations or a compromise in accuracy.

Model 8712U transmitters and other manufacturer's flowtubes can be calibrated at known process conditions or at the Rosemount NIST-Traceable Flow Facility. Transmitters calibrated on site require a two-step procedure to match known flow rate.

Performance Specifications

(System specifications are given using the frequency output and with the unit at referenced conditions.)

Accuracy

Model 8712C/U with Model 8705 Flowtube

System accuracy is $\pm 0.5\%$ of rate from 1 to 30 ft/s (0.3 to 10 m/s); between 0.04 and 1.0 ft/s (0.01 and 0.3 m/s), the system has an accuracy of ± 0.005 ft/s. Analog output has the same accuracy as frequency output plus an additional 0.05% of span.

Model 8712H with Model 8707 Flowtube

System accuracy is $\pm 0.5\%$ of rate from 3 to 30 ft/s (1 to 10 m/s); between 0.04 and 3.0 ft/s (0.01 and 0.3 m/s), the system has an accuracy of ± 0.005 ft/s. Analog output has the same accuracy as frequency output plus an additional 0.05% of span.

Model 8712C/U with Model 8711 Flowtube

System accuracy is $\pm 0.5\%$ of rate from 3 to 30 ft/s (1 to 10 m/s); below 3 ft/s (1 m/s), the system has an accuracy of ± 0.015 ft/s (0.005 m/s). Analog output has the same accuracy as frequency output plus an additional 0.05% of span.

Model 8712U with Other Manufacturers' Flowtubes

When calibrated in the Rosemount Flow Facility, system accuracies as good as 0.5% of rate can be attained. Analog output has the same accuracy as frequency output, plus an additional 0.05% of span.

There is no accuracy specification for other manufacturers' flowtubes calibrated in the process line.

Vibration Effect

$\pm 0.1\%$ of span per SAMA PMC 31.1, Level 2

Repeatability

$\pm 0.1\%$ of reading

Response Time

0.2 seconds maximum response to step change in input

Stability

±0.1% of rate over six months

Ambient Temperature Effect

±1% per 100 °F (37.8 °C)

RFI Effect

Class 1, A, B, C: ±0.5% of span at 3 V/m per SAMA PMC 33.1, wires and conduit

Supply Voltage Effect

Transmitter meets supply voltage effect requirements of SAMA PMC 31.1, Section 5.10.1 through 5.10.5. Transmitter withstands surges in supply voltage as specified in IEEE 472, 1974

Physical Specifications

Materials of Construction

Housing

Low-copper aluminum, NEMA 4X and IEC 529 IP65
Pollution Degree 2

Paint

Polyurethane

Cover Gasket

Rubber

Electrical Connections

Three ¾–14 NPT connections provided on the base of the transmitter. Screw terminals provided for all of the connections. Power wiring connected to the transmitter only. Remote mounted transmitters require only a single conduit connection to the flowtube. Integrally mounted transmitters are factory wired to the flowtube.

Cable Requirements for Remote Transmitters

Description	P/N
Signal Cable (20 AWG) Belden 8762, Alpha 2411 equivalent	08712-0061-0001
Coil Drive Cable (14 AWG) Belden 8720, Alpha 2442 equivalent	08712-0060-0001
Combination Signal and Coil Drive Cable (18 AWG) ⁽¹⁾ Belden 9368 equivalent	08712-0750-0001

(1) Combination signal and coil drive cable is not recommended for high-signal magmeter system. For remote mount installations, combination signal and coil drive cable should be limited to less than 100 ft (30 m).

Remote transmitter installations require equal lengths of signal and coil drive cables. Integrally mounted transmitters are factory wired and do not require interconnecting cables.

Lengths from 5 to 1,000 feet (1.5 to 300 meters) may be specified, and will be shipped with the flowtube. When ordering the combination cable, the lengths specified must be from 5 to 500 feet (1.5 to 150 meters).

Cable longer than 100 feet (30 meters) is not recommended for high-signal systems.

Line Power Fuses

115 V ac systems

1 amp, Quick-acting Bussman AGCI or equivalent.
5 amp, Quick-acting Bussman AGCI or equivalent (Model 8712H only).

230 V ac systems

½ amp, Quick-acting Bussman AGCI or equivalent

10–30 V dc systems

3 amp, Quick-acting Bussman AGCI or equivalent

Transmitter Weight

Transmitter approximately 9 lb (4 kg). Add 1 lb (0.5 kg) for local operator interface.

Model 8732C Magnetic Flowmeter Transmitter Specifications

Functional Specifications

Flowtube Compatibility

Compatible with Rosemount Model 8705 and Model 8711 Flowtubes.

Flowtube Coil Resistance

25 V maximum (Model 8732C)

Flow Rate Range

Capable of processing signals from fluids that are traveling between 0.04 and 30 ft/s (0.01 to 10 m/s) for both forward and reverse flow in all flowtube sizes. Full scale continuously adjustable between -30 and 30 ft/s (-10 to 10 m/s).

Conductivity Limits

Process liquid must have a conductivity of 5 microsiemens/cm (5 micromhos/cm) or greater for Model 8732C. Excludes the effect of interconnecting cable length in remote mount transmitter installations.

Power Supply

85 or 250 V ac $\pm 10\%$, 50-60 Hz or 10-30 V dc

DC Load Limitations (Analog Output)

Maximum loop resistance is determined by the voltage level of the external power supply, as described by:

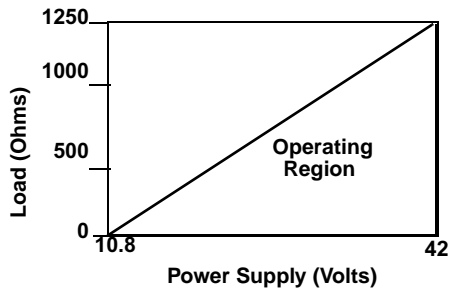

$$R_{\max} = 41.7(V_{ps} - 10.8)$$

V_{ps} = Power Supply Voltage (Volts)

R_{\max} = Maximum Loop Resistance (Ohms)

NOTE

HART Communication requires a minimum loop resistance of 250 ohms.

Supply Current Requirements

Units powered by 15-50 V dc power supply may draw up to 1 amp of current.

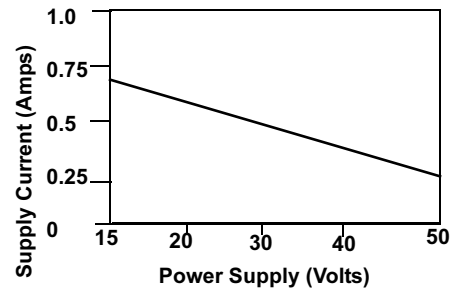

$$I = 10/V$$

I = Supply current requirement (Amps)

V = Power supply voltage (Volts)

Installation Coordination

Installation (overvoltage) Category II

Power Consumption

10 watts maximum

Ambient Temperature Limits

Operating

-40 to 165 °F (-40 to 74 °C) without local operator interface

13 to 149 °F (-25 to 65 °C) with local operator interface

Storage

-40 to 185 °F (-40 to 85 °C)

Humidity Limits

0-100% RH to 150 °F (65 °C)

Series 8700

Output Signals

Analog Output Adjustment

4–20 mA, jumper-selectable as internally or externally powered 5 to 24 V dc; 0 to 1000 Ω load.

Engineering units—lower and upper range values are user-selectable.

Output automatically scaled to provide 4 mA at lower range value and 20 mA at upper range value. Full scale continuously adjustable between -30 and 30 ft/s (-10 to 10 m/sec), 1 ft/s (0.3 m/s) minimum span.

HART Communications, digital flow signal, superimposed on 4–20 mA signal, available for control system interface. 250 Ω required for HART communications.

Scalable Frequency Adjustment

0-1000 Hz, externally powered at 5 to 24 V dc, translator switch closure up to 5.75 w. Pulse value can be set to equal desired volume in selected engineering units. Pulse width adjustable from 0.5 to 100 m/s. Local operator interface automatically calculates and displays maximum allowable output frequency.

Auxiliary Output Function

Externally powered at 5 to 24 V dc, transistor switch closure up to 3 W to indicate either:

Reverse Flow: Activates switch closure output when reverse flow is detected. The reverse flow rate is displayed.

Zero Flow: Activates switch closure output when flow goes to 0 ft/s.

Software Lockout

Security lockout switch on the electronics board can be set to deactivate all LOI and HART-based communicator functions to protect configuration variables from unwanted or accidental change.

Output Testing

Analog Output Test

Transmitter may be commanded to supply a specified current between 3.75 and 23.25 mA.

Pulse Output Test

Transmitter may be commanded to supply a specified frequency between 1 and 1000 Hz.

Turn-on Time

30 minutes to rated accuracy from power up;
5 seconds from power interruption

Start-up Time

0.2 seconds from zero flow

Low Flow Cutoff

Adjustable between 0.001 and 1 ft/s (0.0003 and 0.3 m/s). Below selected value, output is driven to the zero flow rate signal level.

Overrange Capability

Signal output will remain linear until 110% of upper range value or 33 ft/s. The signal output will remain constant above these values. Out of range message displayed on LOI and the HART Communicator.

Damping

Adjustable between 0.2 and 256 seconds

Flowtube Compensation

Rosemount flowtubes are flow-calibrated and assigned a calibration factor at the factory. The calibration factor is entered into the transmitter, enabling interchangeability of flowtubes without calculations or a compromise in accuracy.

Performance Specifications

(System specifications are given using the frequency output and with the unit at reference conditions.)

Accuracy

Model 8732C with Model 8705 Flowtube:

System accuracy is $\pm 0.5\%$ of rate from 1 to 30 ft/s (0.3 to 10 m/s); below 1.0 ft/s (0.3 m/s), the system has an accuracy of ± 0.005 ft/s (0.0015 m/s). Analog output has the same accuracy as frequency output plus an additional 0.05% of span.

Model 8732C with Model 8711 Flowtube:

System accuracy is $\pm 0.5\%$ of rate from 3 to 30 ft/s (0.9 to 10 m/s); below 3 ft/s (0.9 m/s), the system has an accuracy of ± 0.015 ft/s (0.005 m/s). Analog output has the same accuracy as frequency output plus an additional 0.05% of span.

Vibration Effect

Meets IEC 770 Pipeline Installation Conditions

Repeatability

$\pm 0.1\%$ of reading

Response Time

0.2 seconds maximum response to step change in input

Stability

$\pm 0.1\%$ of rate over six months

Ambient Temperature Effect

$\pm 0.25\%$ change over operating temperature range

EMC Compliance

Complies with the increased requirements from the NAMUR Recommendations: May 1993, Part 1. Electromagnetic compatibility (EMC) for process and laboratory apparatus.

Physical Specifications

Materials of Construction

Housing

Low copper aluminum, NEMA 4X and IEC 529 IP66
Pollution Degree II

Paint

Polyurethane

Cover Gasket

Rubber

Electrical Connections

Two $\frac{3}{4}$ –14 NPT connections provided on the transmitter housing. PG13.5 and CM20 adapters are available. Screw terminals provided for all connections. Power wiring connected to transmitter only. Integrally mounted transmitters are factory wired to the flowtube.

Mounting

Transmitter is mounted integrally with the flowtube and does not require interconnecting cables.

Transmitter Weight

Approximately 7 pounds (3.2 kg). Add 1 pound (0.5 kg) for Option Code M4.

Series 8700

Model 8705 Flanged and 8707 High-Signal Flanged Flowtubes Specifications

Functional Specifications

Service

Conductive liquids and slurries

Line Sizes

$\frac{1}{2}$ –36 inch (15–900 mm) for Model 8705

3–36 inch (80–600 mm) for Model 8707

Interchangeability

Model 8705 Flowtubes are interchangeable with Model 8712C/U, Model 8732, and Model 8742C Transmitters. Model 8707 High-Signal Flowtubes are interchangeable with Model 8712H High-Signal Transmitters. System accuracy is maintained regardless of line size or optional features. Each flowtube nameplate has a sixteen-digit calibration number that can be entered into a transmitter through the Local Operator Interface (LOI) or the HART Communicator on the Model 8712C/U/H and the Model 8732C. In a FOUNDATION™ fieldbus environment, the Model 8742C can be configured using the DeltaV™ fieldbus configuration tool or another FOUNDATION fieldbus configuration device. No further calibration is necessary.

Upper Range Limit

30 ft/s (10 m/s)

Process Temperature Limits

Teflon (PTFE) Lining

–20 to 350 °F (–29 to 177 °C)

Tefzel (ETFE) Lining

–20 to 300 °F (–29 to 149 °C)

Polyurethane Lining

0 to 140 °F (–18 to 60 °C)

Neoprene Lining

0 to 185 °F (–18 to 85 °C)

Linatex Lining (Not available for Model 8707)

0 to 158 °F (–18 to 70 °C)

Ambient Temperature Limits

–30 to 150 °F (–34 to 65 °C)

Pressure Limits

Vacuum Limits

Teflon (PTFE) Lining

Full vacuum to 350 °F (177 °C) through 4-inch (100 mm) line sizes. Consult factory for vacuum applications with line sizes of 6 inches (150 mm) or larger.

All Other Standard Flowtube Lining Materials

Full vacuum to maximum material temperature limits for all available line sizes.

Submergence Protection

IP 68. Continuous to 30 feet (10 meters)

Conductivity Limits

Process liquid must have a conductivity of 5 microsiemens/cm (5 micromhos/cm) or greater for Model 8705. Process liquid must have a conductivity of 50 microsiemens/cm (50 micromhos/cm) for Model 8707. Excludes the effect of interconnecting cable length in remote mount transmitter installations.

Product Data Sheet

00813-0100-4727, Rev HA
January 2002

Series 8700

Flowtube Temperature vs. Pressure Limits for ASME B16.5 Class Flanges (1/2- to 24-inch line sizes)⁽¹⁾

Flange Material	Flange Rating	Pressure			
		@ -20 to 100 °F (-29 to 38 °C)	@ 200 °F (93 °C)	@ 300 °F (149 °C)	@ 350 °F (177 °C)
Carbon Steel	Class 150	255 psi	260 psi	230 psi	215 psi
	Class 300	740 psi	675 psi	655 psi	645 psi
	Class 600 ⁽²⁾	1000 psi	800 psi	700 psi	650 psi
	Class 600	1480 psi	NA	NA	NA
304 Stainless Steel	Class 150	275 psi	235 psi	205 psi	190 psi
	Class 300	720 psi	600 psi	530 psi	500 psi
	Class 600 ⁽²⁾	1000 psi	800 psi	700 psi	650 psi
	Class 600	1480 psi	NA	NA	NA

(1) 30- and 36-inch AWWA C207 Table 2 Class D rated to 150 psi at 150 °F (66 °C).

(2) Temperature and Pressure limits limited by liner and electrode interface.

Flowtube Temperature vs. Pressure Limits for DIN Flanges (15 to 600 mm line sizes).

Flange Material	Flange Rating	Pressure			
		@ -196 to 50 °C (-320 to 122 °F)	@ 100 °C (212 °F)	@ 150 °C (302 °F)	@ 175 °C (347 °F)
Carbon Steel	PN 10	10 bar	10 bar	9.6 bar	9 bar
	PN 16	16 bar	16 bar	15.2 bar	14.2 bar
	PN 25	25 bar	25 bar	24 bar	22.5 bar
	PN 40	40 bar	40 bar	37.1 bar	34.5 bar
304 Stainless Steel	PN 10	10 bar	8.4 bar	7.6 bar	7.2 bar
	PN 16	16 bar	13.5 bar	12.2 bar	11.6 bar
	PN 25	25 bar	21.2 bar	19.1 bar	18.2 bar
	PN 40	31.1 bar	27.5 bar	25.8 bar	25.1 bar

Performance Specifications

(System specifications are given using the frequency output and with the unit at referenced conditions.)

Accuracy

Model 8705 with Model 8712C/U, Model 8732C, or Model 8742C

±0.5% of rate from 1 to 30 ft/s (0.3 to 10 m/s). Includes combined effects of linearity, hysteresis, repeatability, and calibration uncertainty. Accuracy is ±0.005 ft/s (±0.0015 m/s) from low-flow cutoff to 1.0 ft/s (0.3 m/s).

Model 8707 with Model 8712C/U/H, Model 8732C, or Model 8742C

±0.5% of rate from 3 to 30 ft/s (1 to 10 m/s). Include combined effects of linearity, hysteresis, repeatability and calibration uncertainty. Accuracy is ±0.015 ft/s (±0.0045 m/s) from low-flow cutoff to 3.0 ft/s (1 m/s).

Vibration Effect

Meets IEC 770 Pipeline Installation Conditions

Mounting Position Effect

None when installed to ensure flowtube remains full

Physical Specifications

Non-Wetted Materials

Flowtube

AISI Type 304 SST

Flanges

Carbon steel, AISI Type 304 SST, or Type 316 SST

Housing

Welded steel

Paint

Polyurethane

Process Wetted Materials

Lining

Teflon (PTFE), Tefzel (ETFE), polyurethane, neoprene, Linatex

Electrodes

316L SST, Hastelloy C-276, tantalum, 90% platinum-10% iridium, titanium

Series 8700

Process Connections

ASME B16.5 (ANSI) Class 150, Class 300, or Class 600
0.5- to 24-inch

AWWA C207 Table 2 Class D
30- and 36-inch

DIN PN 10, 16, 25, and 40

PN10: Not available for flange sizes from 15 to 150 mm
PN16: Not available for flange sizes from 15 to 80 mm
PN 25: Not available for flange sizes from 15 to 150 mm
PN40: Available for all flange sizes

AISI Type 304 SST Sanitary Tri-Clover

3-A approved quick disconnect ferrule-mounted to ASME B16.5 (ANSI) Class 150 flange; 0.5- to 3-inch.

Electrical Connections

Two ¼–14 NPT connections with number 8 screw terminals are provided in the terminal enclosure for electrical wiring.

Grounding Electrode

A grounding electrode is installed similarly to the measurement electrodes through the flowtube lining on Model 8705 flowtubes. It is available in all electrode materials.

Grounding Rings

Grounding rings are installed between the flange and the tube face on both ends of the flowtube. Single ground rings can be installed on either end of the flowtube. They have an I.D. slightly larger than the flowtube I.D. and an external tab to attach ground wiring. Grounding rings are available in 316L SST, Hastelloy-C, titanium, and tantalum.

Lining Protectors

Lining protectors are installed between the flange and the tube face on both ends of the flowtube. The leading edge of lining material is protected by the lining protector; lining protectors cannot be removed once they are installed. Lining protectors are available in 316L SST, Hastelloy-C, and titanium.

Weight

TABLE 1. Flowtube Weight

Nominal Line Size ⁽¹⁾ Inches (mm)	Flowtube Flange Rating		Flowtube Weight lb (kg)
	ASME B16.5 (ANSI)	DIN	
½ (15)	150	PN 40	20(9)
½ (15)	300		22 (10)
1 (25)	150	PN 40	20 (9)
1 (25)	300		22 (10)
1½ (40)	150	PN 40	22 (10)
1½ (40)	300		24 (11)
2 (50)	150	PN 40	26 (12)
2 (50)	300		28 (13)
3 (80)	150	PN 40	40 (18)
3 (80)	300		47 (21)
4 (100)	150	PN 16	48 (22)
4 (100)	300		65 (30)
6 (150)	150	PN 16	81 (37)
6 (150)	300		93 (42)
8 (200)	150	PN 10	110 (50)
8 (200)	300		162 (74)
10 (250)	150	PN 10	220(98)
10 (250)	300		300(136)
12 (300)	150	PN 10	330(150)
12 (300)	300		435(197)
14 (350)	150	PN 10	370(168)
16 (400)	150	PN 10	500(227)
18 (450)	150	PN 10	600(272)
20 (500)	150	PN 10	680(308)
24 (600)	150	PN 10	1,000(454)
30 (750)	125	CF ⁽²⁾	1,400(637)
36 (900)	125	CF ⁽²⁾	1,975(898)

(1) 30- and 36-inch AWWA C207 Table 2 Class D rated to 150 psi at 150 °F (66 °C).

(2) CF = Consult Factory

Model 8711 Wafer Flowtube Specifications

SPECIFICATIONS

Functional Specifications

Service

Conductive liquids and slurries

Line Sizes

0.15- through 8-inch (4 through 200 mm)

Interchangeability

Model 8711 Flowtubes are interchangeable with Model 8712C/U, Model 8732, and Model 8742C Transmitters. System accuracy is maintained regardless of line size or optional features. Each flowtube nameplate has a sixteen-digit calibration number that can be entered into a transmitter through the Local Operator Interface (LOI) or the HART Communicator on the Model 8712C/U/H and the Model 8732C. In a FOUNDATION fieldbus environment, the Model 8742C can be configured using the DeltaV fieldbus configuration tool or another FOUNDATION fieldbus configuration device. No further calibration is necessary.

Upper Range Limit

30 ft/s (10 m/s)

Process Temperature Limits

Tefzel (ETFE) Lining

-20 to 300 °F (-29 to 149 °C) for 0.5- through 8-inch (15–200 mm) line sizes

-20 to 200 °F (-29 to 93 °C) for 0.15- and 0.3-inch (4 and 8 mm) line sizes

Teflon (PTFE) Lining

-20 to 350 °F (-29 to 177 °C)

Ambient Temperature Limits

-30 to 150 °F (-34 to 65 °C)

Maximum Safe Working Pressure at 100 °F (38 °C)

Tefzel (ETFE) Lining

Full vacuum to 740 psi (5.1 MPa) for 0.5- through 8-inch (15 through 200 mm) flowtubes

285 psi (1.96 MPa) for 0.15- and 0.30-inch (4 and 8 mm) flowtubes

Teflon (PTFE) Lining

Full vacuum through 4-inch (100 mm) line sizes. Consult factory for vacuum applications with line sizes of 6 inches (150 mm) or larger.

Conductivity Limits

Process liquid must have a conductivity of 5 microsiemens/cm (5 micromhos/cm) or greater for Model 8711. Excludes the effect of interconnecting cable length in remote mount transmitter installations.

Performance Specifications

(System specifications are given using the frequency output and with the unit at referenced conditions.)

Accuracy

Model 8711 with Model 8712C/U, Model 8732C, or Model 8742C Transmitters

±0.5% of rate from 3 to 30 ft/s (1 to 10 m/s)

±0.015 ft/s (0.045 m/s) from low-flow cutoff to 3 ft/s (1 m/s)

Vibration Effect

Meets IEC 770 Pipeline Installation Conditions

Mounting Position Effect

No effect when installed to ensure flowtube remains full

Physical Specifications

Non-Wetted Materials

Flowtube

303 SST (ASTM A-743)

Coil Housing

Investment cast steel (ASTM A-27)

Paint

Polyurethane

Process-Wetted Materials

Lining

Tefzel (ETFE), Teflon (PTFE)

Electrodes

316L SST, Hastelloy C-276, tantalum, 90% platinum—10% iridium, titanium

Series 8700

Process Connections

Mounts between these Flange Configurations

ASME B16.5 (ANSI): Class 150, 300.vv

DIN: PN 10 and 25

BS: 10 Table D, E, and F

Studs, Nuts, and Washers⁽¹⁾

ASME B16.5 (ANSI)

0.15- through 1-inch (4 through 25 mm):

316 SST, ASTM A193, Grade B8M, Class 1 threaded mounting studs; ASTM A194, Grade 8M heavy hex nuts; SAE per ANSI B18.2.1, Type A, Series N flat washers.

1.5- through 8-inch (40 through 200 mm):

CS, ASTM A193, Grade B7, Class 1 threaded mounting studs; ASTM A194, Grade 2H heavy hex nuts; SAE per ANSI B18.2.1, Type A, Series N flat washers; all items clear, chromate zinc-plated.

DIN

4 through 25 mm (0.15- through 1-inch):

316 SST ASTM A193, Grade B8M Class 1 threaded mounting studs; ASTM A194, Grade 8M, DIN 934 H=D, metric heavy hex nuts; 316 SST, A4, DIN 125 flat washers.

40 through 200 mm (1.5- through 8-inch):

CS, ASTM A193, Grade B7 threaded mounting studs; ASTM A194, Grade 2H, DIN 934 H=D, metric heavy hex nuts; CS, DIN 125 flat washers; all items yellow zinc-plated.

(1) 0.15 and 0.30 inch (4 and 80 mm) flowtubes mount between 1/2-inch flange.

TABLE 2. Flowtube Dimensions and Weight.

Nominal Line Size Inches (mm)	Flowtube Housing Dimensions						Flowtube Length		Inside Diameter		Weight lb (kg)
	"A" Max.	"B"	"C"	"D"							
0.15 ⁽¹⁾ (4)	4.00 (102)	5.44 (138)	3.56 (90)	2.17 (55)	.165 (4)	4 (2)					
0.30 ⁽¹⁾ (8)	4.00 (102)	5.44 (138)	3.56 (90)	2.17 (55)	.287 (7)	4 (2)					
0.5 (15)	4.00 (102)	5.44 (138)	3.56 (90)	2.17 (55)	.595 (15)	4 (2)					
1 (25)	4.31 (109)	6.06 (154)	4.50 (114)	2.17 (55)	.959 (24)	5 (2)					
1.5 (40)	4.42 (112)	7.41 (188)	3.28 (83)	2.73 (69)	1.50 (38)	5 (2)					
2 (50)	4.64 (118)	7.94 (202)	3.91 (99)	3.26 (83)	1.95 (50)	7 (3)					
3 (80)	5.26 (134)	9.19 (233)	5.16 (131)	4.68 (119)	2.98 (76)	13 (6)					
4 (100)	5.87 (149)	10.41 (264)	6.38 (162)	5.88 (149)	3.90 (99)	22 (10)					
6 (150)	6.97 (177)	12.60 (320)	8.56 (217)	6.87 (174)	5.825 (148)	35 (16)					
8 (200)	8.00 (2003)	14.66 (372)	10.63 (270)	8.86 (225)	7.87 (200)	60 (27)					

(1) 0.15 and 0.30 inch (4 and 8 mm) flowtubes mount between 1/2-inch (13 mm) flange.

Electrical Connections

Two 3/4-14 NPT connections with number 8 screw terminals are provided in the terminal enclosure for electrical wiring.

Grounding Electrode

A grounding electrode is installed similarly to the measurement electrodes through the flowtube lining. It is available in all electrode materials.

Grounding Rings

Grounding rings are installed between the flange and the tube face on both ends of the flowtube. They have an I.D. slightly larger than the flowtube I.D. and an external tab to attach ground wiring. Grounding rings are available in 316L SST, Hastelloy C-276, titanium, and tantalum.

Flowtube Dimensions and Weight

See Table 2

Model 8714D Reference Calibration Standard Specifications

Functional Specifications

Ambient Temperature Limits

Operating

-30 to 140 °F (-34 to 60 °C)

Storage

-40 to 140 °F (-40 to 60 °C)

Humidity Limits

0 to 95% relative humidity

Performance Specifications

Accuracy

±0.05% of rate at 30 ft/s

±0.10% of rate at 10 ft/s and 3 ft/s

Warm-up Time

30 minutes

Ambient Temperature Effect

< 0.015% of rate per 10 °F (< 0.027% per 10 °C)

Humidity Effect

No effect from 0 to 60% relative humidity

< 0.10% of rate from 60 to 90% relative humidity

Long-Term Stability

< 0.10% of rate shift in one year

Physical Specifications

Electrical Connections

Electrical connections are compatible with Model 8712C/U or Model 8732C terminal blocks. Electrical connections are not compatible with Model 8712H terminal block.

Mounting

Any position is acceptable

Materials of Construction

Housing

Extruded aluminum

Covers

Stamped aluminum, silk-screened

Paint

Epoxy polyester

Weight

Approximately 3 lb (2 kg)

Hazardous Location Certifications

Equivalent Hazardous Location Certifications for flowtube and transmitter must match in integrally-mounted magnetic flowmeter systems. Remote-mounted systems do not require matched hazardous location certification option codes.

NOTE

Additional approvals pending, consult the factory for availability.

TABLE 3. Order Code

Agency	Model 8712C/U	Model 8712H	Model 8732
CSA	N0	N0	N0
FM	N0	N0	N0
	N5	N5	N5
			E5
CENELEC/KEMA	CE		ED

NOTE:

Model 8712C/U transmitters are CE compliant only with the CE option code.
Model 8712H transmitters are not CE compliant.
All Model 8732 transmitters are CE compliant.

TABLE 4. Order Code All Configurations shown in this table are CE Compliant unless otherwise noted.

Agency	Model 8705 Flowtube		Model 8707 Flowtube		Model 8711 Flowtube	
	For Non-flammable Fluids	For Flammable Fluids	For Non-flammable Fluids	For Flammable Fluids	For Non-flammable Fluids	For Flammable Fluids
CSA	N0		N0 ⁽¹⁾		N0	
FM	N0	N5	N0 ⁽¹⁾		N0	N5
						E5
CENELEC/KEMA	N0 ⁽²⁾	KD			N0 ⁽²⁾	CD

(1) Not CE Compliant

(2) Pending approval, consult factory for availability

Product Data Sheet

00813-0100-4727, Rev HA

January 2002

Series 8700

- N0** Factory Mutual (FM) Approval for Non-incendive, non-flammable fluid service in Class I, Division 2, Groups E, F, and G; Dust-ignition proof for Class II/III, Division 1; T4 Temperature code (Model 8742 transmitter), and T5 temperature code (Model 8705, 8707, and 8711 flowtubes) Enclosure Rating - NEMA 4x.
AND
Canadian Standards Association (CSA) Suitable for Class I, Division 2, Groups A, B, C, and D; Dust-Ignition Proof for Class II/III, Division 1, Groups E, F, and G Enclosure Type 4x
AND
KEMA/CENELEC Ex nL IIB ⁽¹⁾ (Model 8705 and 8711 flowtubes only)
AND
CE Marking.
- N5** Factory Mutual (FM) Approval for Non-incendive, flammable fluid service in Class I, Division 2, Groups E, F, and G; T4 Temperature code (Model 8742 transmitter), and T5 Temperature code (Model 8705, and 8711 flowtubes).
- E5** Factory Mutual (FM) Approval for flammable process fluid service in Class I, Division 1, Groups C and D; T4 Temperature code (Model 8742 transmitter), T6 Temperature Code (Model 8711 flowtube).
- ED** Available on Model 8742 transmitter only. KEMA/CENELEC EEx d [ia] IIB T6 Flameproof Approval with Intrinsically Safe fieldbus connections when connected in accordance with Rosemount drawing 08742-1051. Fieldbus Entity Parameters:
 $V_{max} = 30V$
 $I_{max} = 300\text{ mA}$
 $C_i = 4.4\ \mu F$
 $L_i = 0.0\ \mu H$
CE Marking.
- CD** Available on Model 8711 flowtube only. KEMA/CENELEC EEx e ia II C T3...T6; Increased Safety with I.S. Electrodes; CE Marking.
- KD** KEMA/CENELEC EEx e ia IIC T3...T6; Increased Safety Approval
AND
CE Marking.

(1) Pending approval, consult factory for availability

Dimensional Drawings

Model 8712C/U/H Transmitter Dimension Drawings and Field Wiring

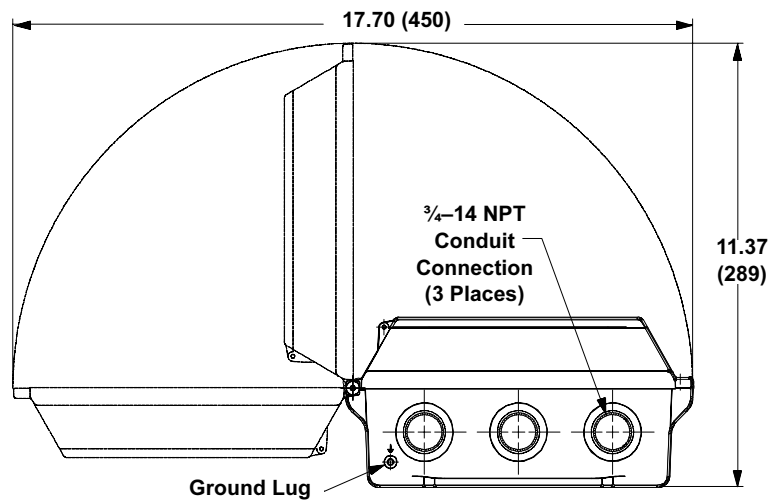
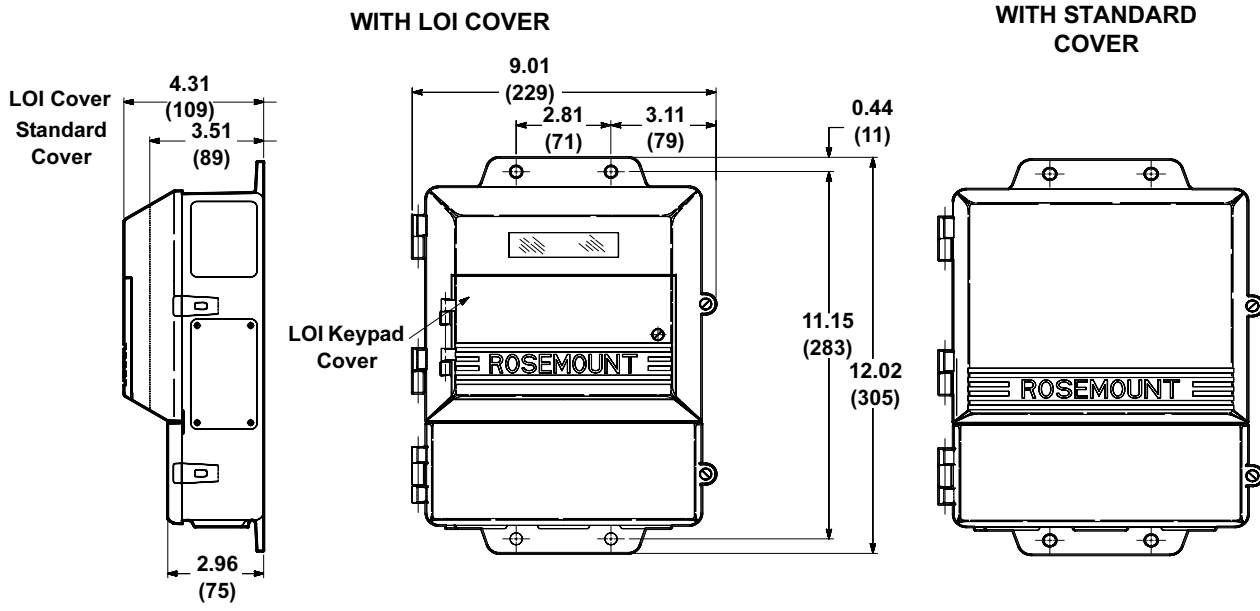

NOTE
 Dimensions are in inches (millimeters)

8712-12A01A, 8712B01A, 8712C01A, 8712D01A

Model 8732C Dimensional Drawings

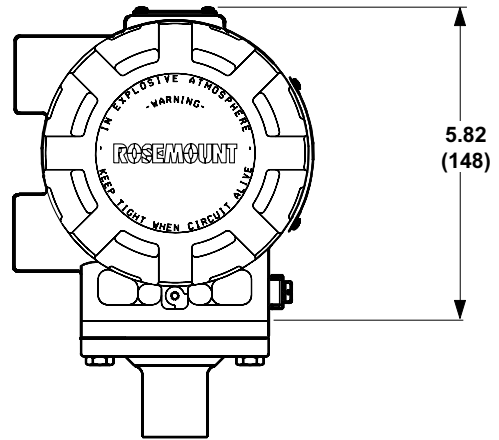
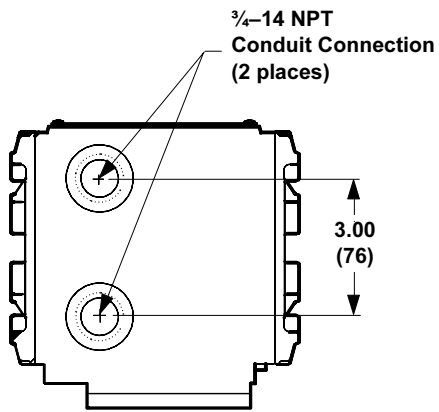
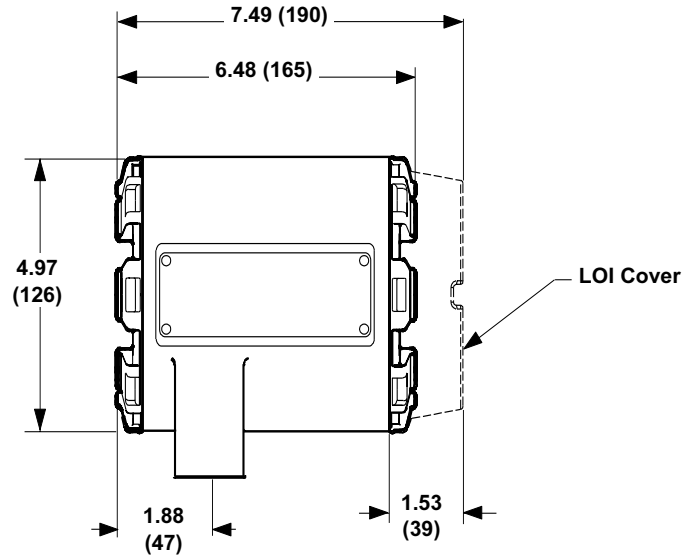

NOTE
Dimensions are in inches (millimeters)

8732-1002B01A, 1002F01A, 1002G01A

Model 8732 Remote Mount

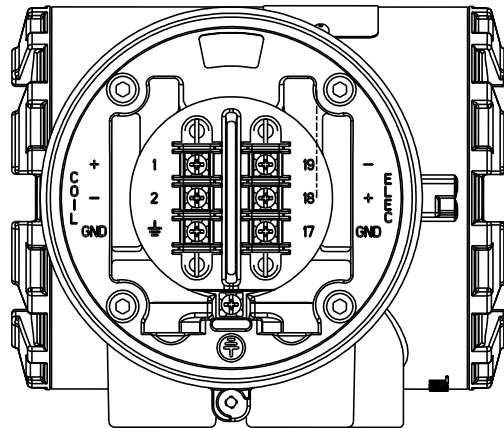
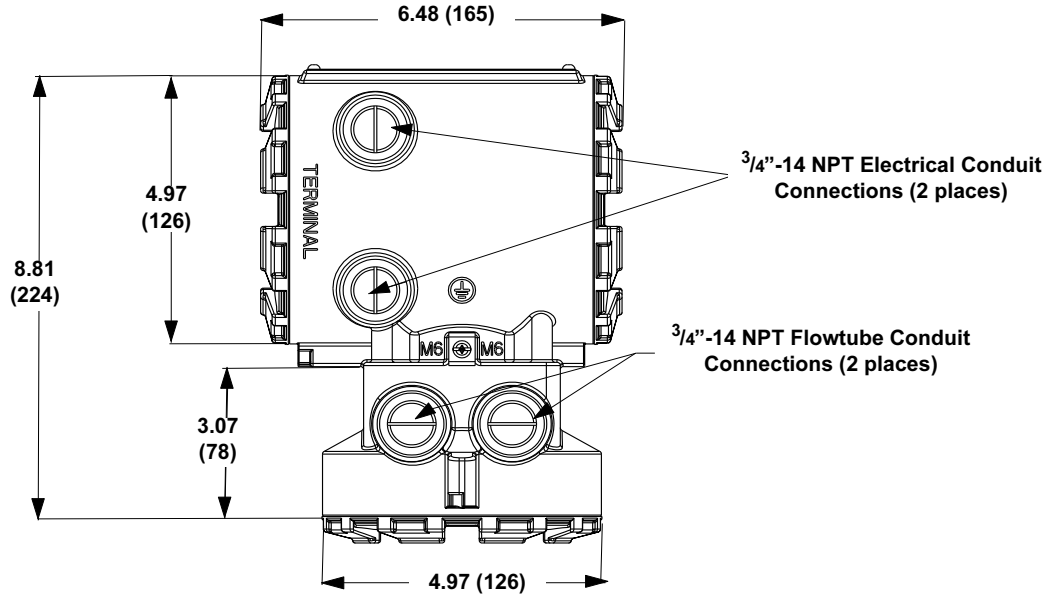

Note
 Dimensions in inches (millimeters)

8742-8742_06A, 8742_06B

Product Data Sheet

00813-0100-4727, Rev HA

January 2002

Series 8700

TABLE 5. Model 8705 and Model 8707 Dimensions in Inches (Millimeters)
Refer to Dimensional Drawings, Figure , Figure , and Figure

Line Size ⁽¹⁾ and Flange Rating (ASME B 16.5)	Liner Face Diameter "A"	Process Flange Rad. "B"	Overall Flowtube Length "L" ⁽²⁾	Body Height "C"	Body Width "D"	Centerline to Conduit "E"	Bolt Hole Circle Diameter	Bolt Hole Diameter	Number and Size of Bolts
0.5-150	1.38 (35)	1.75 (44)	7.88 (200)	9.25 (235)	6.88 (175)	4.71 (120)	2.38 (60)	0.62 (16)	4-1/2
0.5-300	1.38 (35)	1.88 (48)	7.88 (200)	9.25 (235)	6.88 (175)	4.71 (120)	2.62 (67)	0.62 (16)	4-1/2
1-150	2.00 (51)	2.13 (54)	7.88 (200)	9.25 (235)	7.34 (186)	4.71 (120)	3.12 (79)	0.62 (16)	4-1/2
1-300	2.00 (51)	2.44 (62)	7.88 (200)	9.25 (235)	7.34 (186)	4.71 (120)	3.50 (89)	0.75 (19)	4-5/8
1.5-150	2.88 (73)	2.50 (64)	7.88 (200)	10.02 (255)	7.05 (179)	5.12 (130)	3.88 (99)	0.62 (16)	4-1/2
1.5-300	2.88 (73)	3.06 (78)	7.88 (200)	10.02 (255)	7.05 (179)	5.12 (130)	4.50 (114)	0.88 (22)	4-3/4
2-150	3.62 (92)	3.00 (76)	7.88 (200)	10.02 (255)	7.47 (190)	5.12 (130)	4.75 (121)	0.75 (19)	4-5/8
2-300	3.62 (92)	3.25 (83)	7.88 (200)	10.02 (255)	7.47 (190)	5.12 (130)	5.00 (127)	0.75 (19)	8-5/8
3-150	5.00 (127)	3.75 (95)	7.88 (200)	12.02 (306)	9.57 (243)	6.12 (156)	6.00 (152)	0.75 (19)	4-5/8
3-300	5.00 (127)	4.13 (105)	8.63 (219)	12.02 (306)	9.57 (243)	6.12 (156)	6.62 (168)	0.88 (22)	8-3/4
4-150	6.19 (157)	4.50 (114)	9.84 (250)	12.72 (323)	10.01 (254)	6.47 (165)	7.50 (191)	0.75 (19)	8-5/8
4-300	6.19 (157)	5.00 (127)	10.88 (276)	12.72 (323)	10.01 (254)	6.47 (165)	7.88 (200)	0.88 (22)	8-3/4
6-150	8.50 (216)	5.50 (140)	11.81 (300)	14.89 (379)	10.41 (264)	7.60 (193)	9.50 (241)	0.88 (22)	8-3/4
6-300	8.50 (216)	6.25 (159)	13.06 (332)	14.89 (379)	10.41 (264)	7.60 (193)	10.62 (270)	0.88 (22)	12-3/4
8-150	10.62 (270)	6.75 (171)	13.78 (350)	16.83 (428)	11.38 (289)	8.57 (218)	11.75 (298)	0.88 (22)	8-3/4
8-300	10.62 (270)	7.50 (191)	15.60 (396)	16.83 (428)	11.38 (289)	8.57 (218)	13.00 (330)	1.00 (25)	12-7/8
10-150	12.75 (324)	8.00 (203)	15.00 (381)	19.61 (498)	17.00 (432)	9.99 (254)	14.25 (362)	1.00 (25)	12-7/8
10-300	12.75 (324)	8.75 (225)	17.13 (435)	19.61 (498)	17.00 (432)	9.99 (254)	15.25 (387)	1.12 (28)	16-1
12-150	15.00 (381)	9.50 (241)	18.00 (457)	21.77 (553)	19.16 (487)	11.07 (282)	17.00 (432)	1.00 (25)	12-7/8
12-300	15.00 (381)	10.25 (260)	20.14 (512)	21.77 (553)	19.16 (487)	11.07 (282)	17.75 (451)	1.25 (32)	16-1 1/8
14-150	16.25 (413)	10.50 (267)	21.00 (533)	23.89 (607)	21.28 (541)	12.13 (309)	18.75 (476)	1.12 (28)	12-1
14-300	16.25 (413)	11.50 (292)	23.25 (591)	23.89 (607)	21.28 (541)	12.13 (309)	20.25 (514)	1.25 (32)	20-1 1/8
16-150	18.50 (470)	11.75 (298)	24.00 (610)	25.91 (658)	23.30 (592)	13.14 (334)	21.25 (540)	1.12 (28)	16-1
16-300	18.50 (470)	12.75 (324)	26.25 (667)	25.91 (658)	23.30 (592)	13.14 (334)	22.50 (572)	1.38 (35)	20-1 1/4
18-150	21.00 (533)	12.50 (318)	27.00 (686)	28.43 (722)	25.82 (656)	14.4 (366)	22.75 (578)	1.25 (32)	16-1 1/8
18-300	21.00 (533)	14.00 (356)	30.12 (765)	28.43 (722)	25.82 (656)	14.4 (366)	24.75 (629)	1.38 (35)	24-1 1/4
20-150	23.00 (584)	13.75 (349)	30.00 (762)	30.45 (774)	27.84 (707)	15.41 (392)	25.00 (635)	1.25 (32)	20-1 1/8
20-300	23.00 (584)	15.25 (387)	33.25 (845)	30.45 (774)	27.84 (707)	15.41 (392)	27.00 (686)	1.38 (35)	24-1 1/4
24-150	27.25 (692)	16.00 (406)	36.00 (914)	35.00 (889)	32.39 (823)	17.69 (450)	29.50 (749)	1.37 (35)	20-1 1/4
24-300	27.25 (692)	18.00 (457)	39.64 (1007)	35.00 (889)	32.39 (823)	17.69 (450)	32.00 (813)	1.62 (41)	24-1 1/2
30	33.80 (859)	19.38 (492)	37.25 (946)	40.91 (1039)	38.50 (928)	20.86 (530)	36.00 (914)	1.38 (35)	28-1 1/4
36	40.27 (1023)	23.00 (584)	40.75 (1035)	48.79 (1240)	46.38 (1178)	24.80 (630)	42.75 (1086)	1.63 (41)	32-1 1/2

Dimensions with ASME B16.5 (ANSI) Flanges

(1) 30- and 36-inch AWWA C207 Table 2 Class D rated to 150 psi at 150 °F.

(2) When grounding rings (2 rings per meter) are specified, add 0.25 inch (6.35 mm) for 0.50- through 14-inch (15 through 350 mm) flowtubes, add 0.50 inch (12.7 mm) for 16-inch (400 mm) and larger. When lining protectors are specified, add 0.25 inch (6.35 mm) for 1/2- through 12-inch (15 through 300 mm) flowtubes, add 0.50 inch (12.7 mm) for 14- through 36-inch (350 through 900 mm) flowtubes.

TABLE 6. Sanitary Model 8705 Flowtube Dimensions in inches (millimeters)

Line Size and Flange Rating	Nominal Tri-Clamp Diameter	Process Flange Rad. "B"	Body Height "C" Max	Centerline to Conduit "E"	Overall Flowtube Length "L"
0.5-150 lb.	1.00 (25)	1.75 (44)	8.88 (226)	4.71 (120)	13.78 (350)
1-150 lb.	1.50 (40)	2.13 (54)	8.88 (226)	4.71 (120)	13.78 (350)
1.5-150 lb.	2.00 (50)	2.50 (64)	9.50 (242)	5.11 (130)	13.78 (350)
2-150 lb.	3.00 (80)	3.00 (76)	9.50 (242)	5.11 (130)	13.78 (350)
3-150 lb.	4.00 (100)	3.75 (95)	12.50 (318)	6.12 (156)	13.78 (350)

Dimensions with ASME B16.5 (ANSI) Flanges and Tri-Clamp Adapters.

Series 8700

TABLE 7. Model 8705 Flowtube Dimensions with DIN Flanges in Millimeters (Inches)

Line Size ⁽¹⁾ and Flange Rating	Liner Face Diameter "A"	Process Flange Rad. "B"	Overall Flowtube Length "L" ⁽²⁾	Body Height "C"	Body Width "D" with Port	Centerline to Conduit "E"	Bolt Hole Circle Diameter	Bolt Hole Diameter	Number of Bolts
15 mm PN 10-40	45 (1.77)	47 (1.87)	200 (7.88)	235 (9.25)	175 (6.88)	120 (5.16)	65 (2.56)	14 (0.55)	4
25 mm PN 10-40	68 (2.68)	58 (2.27)	200 (7.88)	235 (9.25)	186 (7.34)	120 (5.16)	85 (3.35)	14 (0.55)	4
40 mm PN 10-40	88 (3.46)	75 (2.96)	200 (7.87)	255 (10.02)	179 (7.05)	130 (5.57)	110 (4.33)	18 (0.71)	4
50 mm PN 10-40	102 (4.02)	83 (3.25)	200 (7.87)	255 (10.02)	190 (7.47)	130 (5.57)	125 (4.92)	18 (0.71)	4
80 mm PN 10-40	138 (5.43)	100 (3.94)	200 (7.87)	306 (12.02)	243 (9.57)	156 (6.57)	160 (6.30)	18 (0.71)	8
100 mm PN 10-16	158 (6.22)	110 (4.33)	250 (9.84)	323 (12.72)	254 (10.01)	165 (6.92)	180 (7.09)	18 (0.71)	8
100 mm PN 25-40	162 (6.38)	117 (4.63)	250 (9.84)	323 (12.72)	254 (10.01)	165 (6.92)	190 (7.48)	22 (0.87)	8
150 mm PN 10-16	212 (8.35)	142 (5.61)	300 (11.81)	379 (14.89)	264 (10.41)	193 (8.05)	240 (9.45)	22 (0.87)	8
150 mm PN 25	218 (8.58)	150 (5.91)	300 (11.81)	379 (14.89)	264 (10.41)	193 (8.05)	240 (9.45)	22 (0.87)	8
150 mm PN 40	218 (8.58)	150 (5.91)	332 (13.06)	379 (14.89)	264 (10.41)	193 (8.05)	240 (9.45)	22 (0.87)	8
200 mm PN 10	268 (10.55)	170 (6.70)	351 (13.81)	428 (16.83)	289 (13.38)	218 (9.02)	295 (11.61)	22 (0.87)	8
200 mm PN 16	268 (10.55)	170 (6.70)	351 (13.81)	428 (16.83)	289 (13.38)	218 (9.02)	295 (11.61)	22 (0.87)	8
200 mm PN 25	278 (10.94)	180 (7.09)	350 (13.78)	428 (16.83)	289 (13.38)	218 (9.02)	310 (12.20)	26 (1.02)	12
200 mm PN 40	285 (11.22)	187 (7.38)	396 (15.60)	428 (16.83)	289 (13.38)	218 (9.02)	320 (12.60)	30 (1.18)	12
250 mm PN 10	320 (12.60)	197 (7.70)	381 (15.00)	498 (19.61)	432 (17.00)	254 (10.44)	350 (13.78)	22 (0.87)	12
250 mm PN 16	320 (12.60)	202 (7.97)	381 (15.00)	498 (19.61)	432 (17.00)	254 (10.44)	355 (13.98)	26 (1.02)	12
250 mm PN 25	335 (13.19)	213 (8.39)	381 (15.00)	498 (19.61)	432 (17.00)	254 (10.44)	370 (14.67)	30 (1.18)	12
250 mm PN 40	345 (13.58)	225 (8.86)	435 (17.13)	498 (19.61)	432 (17.00)	254 (10.44)	385 (15.16)	33 (1.30)	12
300 mm PN 10	370 (14.57)	223 (8.76)	457 (18.00)	553 (21.77)	487 (19.16)	254 (10.44)	400 (15.75)	22 (0.87)	12
300 mm PN 16	378 (14.88)	230 (9.06)	457 (18.00)	553 (21.77)	487 (19.16)	282 (11.52)	410 (16.14)	26 (1.02)	12
300 mm PN 25	395 (15.55)	242 (9.55)	457 (18.00)	553 (21.77)	487 (19.16)	282 (11.52)	430 (16.93)	30 (1.18)	16
300 mm PN 40	410 (16.14)	258 (10.12)	512 (20.14)	553 (21.77)	487 (19.16)	282 (11.52)	450 (17.72)	33 (1.30)	16
350 mm PN 10	430 (16.93)	252 (9.94)	534 (21.03)	607 (23.89)	541 (21.28)	282 (11.52)	460 (18.11)	22 (0.87)	16
350 mm PN 16	438 (17.24)	260 (10.24)	534 (21.03)	607 (23.89)	541 (21.28)	309 (12.58)	470 (18.50)	26 (1.02)	16
350 mm PN 25	450 (17.72)	277 (10.93)	534 (21.03)	607 (23.89)	541 (21.28)	309 (12.58)	490 (19.29)	33 (1.30)	16
350 mm PN 40	465 (18.31)	290 (11.42)	591 (23.25)	607 (23.89)	541 (21.28)	309 (12.58)	510 (20.08)	36 (1.42)	16
400 mm PN 10	482 (18.98)	282 (11.12)	610 (24.00)	658 (25.54)	592 (23.30)	334 (13.59)	515 (20.28)	26 (1.02)	16
400 mm PN 16	490 (19.29)	290 (11.42)	610 (24.00)	658 (25.54)	592 (23.30)	334 (13.59)	525 (20.67)	30 (1.18)	16
400 mm PN 25	505 (19.88)	310 (12.21)	610 (24.00)	658 (25.54)	592 (23.30)	334 (13.59)	550 (21.65)	36 (1.42)	16
400 mm PN 40	535 (21.06)	330 (12.99)	667 (26.25)	658 (25.54)	592 (23.30)	334 (13.59)	585 (23.03)	39 (1.54)	16
450 mm PN 10	532 (20.94)	308 (12.13)	686 (27.00)	722 (28.43)	656 (25.82)	366 (14.85)	565 (22.24)	26 (1.02)	20
450 mm PN 16	550 (21.65)	320 (12.60)	686 (27.00)	722 (28.43)	656 (25.82)	366 (14.85)	585 (23.03)	30 (1.18)	20
450 mm PN 40	560 (22.05)	343 (13.50)	765 (30.12)	722 (28.43)	656 (25.82)	366 (14.85)	610 (24.02)	30 (1.18)	20
500 mm PN 10	585 (23.03)	335 (13.19)	762 (30.00)	774 (30.45)	707 (27.84)	392 (15.86)	620 (24.41)	26 (1.02)	20
500 mm PN 16	610 (24.02)	358 (14.08)	762 (30.00)	774 (30.45)	707 (27.84)	392 (15.86)	650 (25.59)	33 (1.30)	20
500 mm PN 25	615 (24.21)	365 (14.37)	762 (30.00)	774 (30.45)	707 (27.84)	392 (15.86)	660 (25.98)	36 (1.42)	20
500 mm PN 40	615 (24.21)	378 (14.88)	845 (33.25)	774 (30.45)	707 (27.84)	392 (15.86)	670 (26.38)	42 (1.65)	20
600 mm PN 10	685 (26.97)	390 (15.36)	914 (36.00)	898 (35.35)	823 (32.39)	450 (18.14)	725 (28.54)	30 (1.18)	20
600 mm PN 16	725 (28.54)	420 (16.54)	914 (36.00)	890 (35.01)	823 (32.39)	450 (18.14)	770 (30.31)	36 (1.42)	20
600 mm PN 25	720 (28.35)	423 (16.64)	914 (36.00)	890 (35.01)	823 (32.39)	450 (18.14)	770 (30.31)	39 (1.54)	20
600 mm PN 40	735 (18.94)	445 (17.52)	1,007 (39.64)	899 (35.38)	823 (32.39)	450 (18.14)	795 (31.30)	48 (1.88)	20

Dimensions with DIN Flanges

(1) Consult factory for larger line sizes.

(2) When grounding rings (2 rings per meter) are specified, add 6.35 mm (0.25 in.) for 15 mm through 350 mm (½- through 14 in.) flowtubes or 12.7 mm (0.50 in.) for 400 mm (16 in.) and larger. When lining protectors are specified, add 6.35 mm (0.25 in.) for 15 mm through 300 mm (½- through 12-in.) flowtubes, 12.7 mm (0.50 in.) for 350 mm through 900 mm (14- through 36-in.) flowtubes.

MODEL 8705 DIMENSIONAL DRAWINGS

**Dimensional Drawing of Model 8705 and Model 8707 Flowtubes,
 Typical of 0.5- through 4-inch (15 through 100 mm) Line Sizes
 with Option Code W1, Housing Configuration**

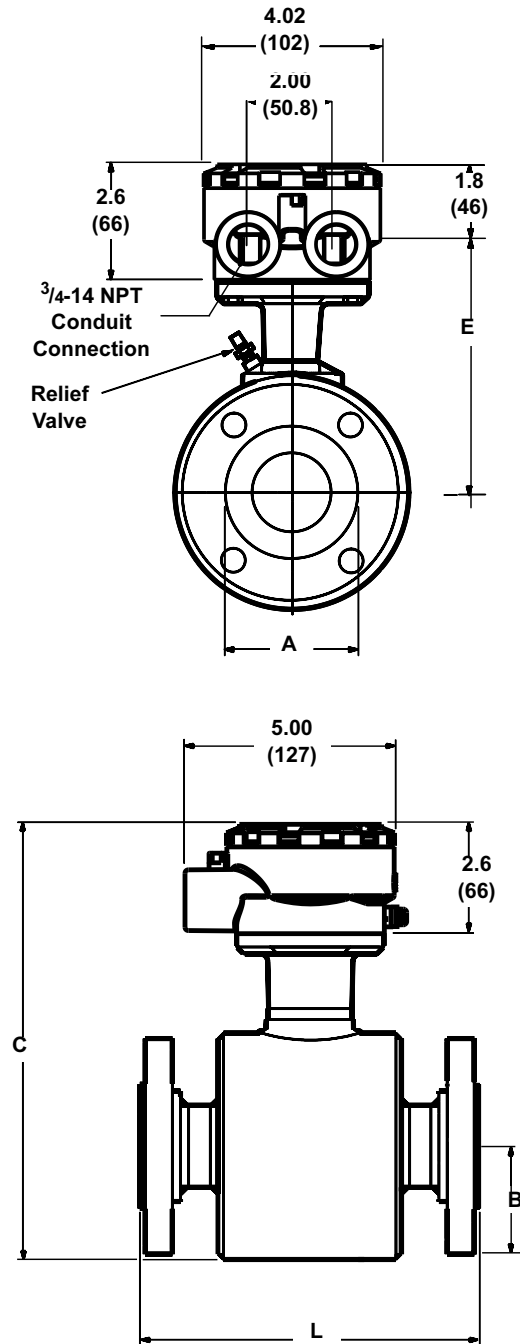

Notes
 Dimensions are in inches (millimeters)
 See Table 5 and Table 7 for variable dimensions

8705-1002A05A, 1002B05A

**Dimensional Drawing of Model 8705 and Model 8707 Flowtubes,
 Typical of 6- through 36-inch (150 through 900 mm) Line Sizes
 with Option Code W3, Housing Configuration**

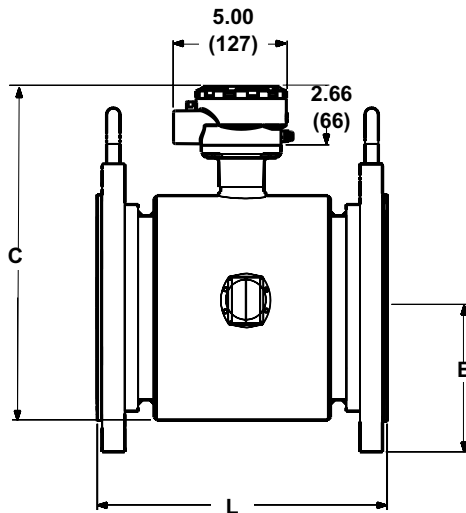
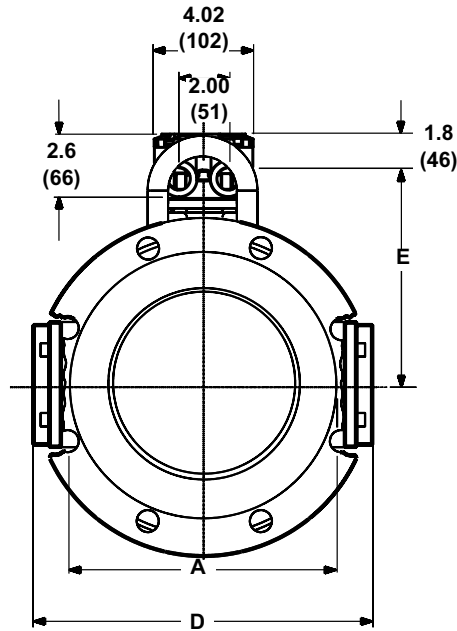

Notes
 Dimensions are in inches (millimeters)
 Consult factory for larger line sizes
 See Table 5 and Table 7 for variable dimensions

8705-1002A06A, 1002B06A

**Dimensional Drawing of Model 8705 Sanitary Flowtubes,
 Typical of 1/2- through 3-inch (15 through 86 mm) Line Sizes
 with Option Code W0, Housing Configuration**

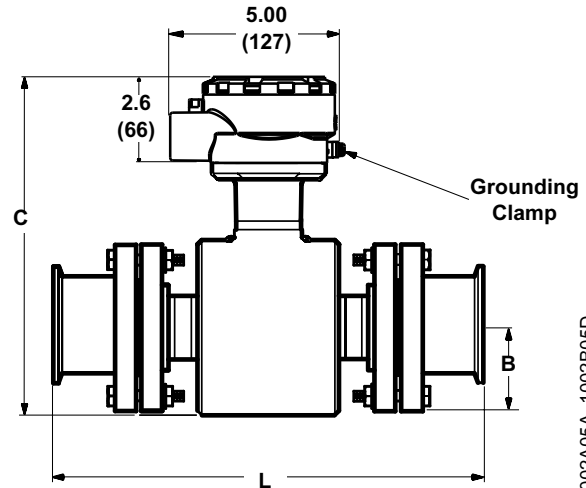
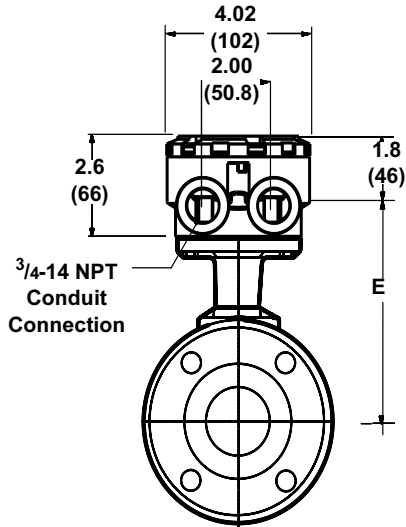

8705-1002A05A, 1002B05D

Notes
 Dimensions are in inches (millimeters)
 See Table 7 for available dimensions

TABLE 8. Model 8711 Flowtube Dimensions and Weight

Nominal Line Size Inches (mm)	Flowtube Housing Dimensions						Flowtube Length		Inside Diameter		Weight lb (kg)
	"A" Max.	"B"	"C"	"D"	"D"	"D"	"D"	"D"	"D"		
0.15 ⁽¹⁾ (4)	4.00 (102)	5.44 (138)	3.56 (90)	2.17 (55)	.165 (4)	4 (2)					
0.30 ⁽¹⁾ (8)	4.00 (102)	5.44 (138)	3.56 (90)	2.17 (55)	.287 (7)	4 (2)					
0.5 (15)	4.00 (102)	5.44 (138)	3.56 (90)	2.17 (55)	.595 (15)	4 (2)					
1 (25)	4.31 (109)	6.06 (154)	4.50 (114)	2.17 (55)	.959 (24)	5 (2)					
1.5 (40)	4.42 (112)	7.41 (188)	3.28 (83)	2.73 (69)	1.50 (38)	5 (2)					
2 (50)	4.64 (118)	7.94 (202)	3.91 (99)	3.26 (83)	1.95 (50)	7 (3)					
3 (80)	5.26 (134)	9.19 (233)	5.16 (131)	4.68 (119)	2.98 (76)	13 (6)					
4 (100)	5.87 (149)	10.41 (264)	6.38 (162)	5.88 (149)	3.90 (99)	22 (10)					
6 (150)	6.97 (177)	12.60 (320)	8.56 (217)	6.87 (174)	5.825 (148)	35 (16)					
8 (200)	8.00 (2003)	14.66 (372)	10.63 (270)	8.86 (225)	7.87 (200)	60 (27)					

(1) 0.15 and 0.30 inch (4 and 8 mm) flowtubes mount between 1/2-inch (13 mm) flange.

Model 8711 Dimensional Drawings (1.5-inch through 8-inch line sizes)

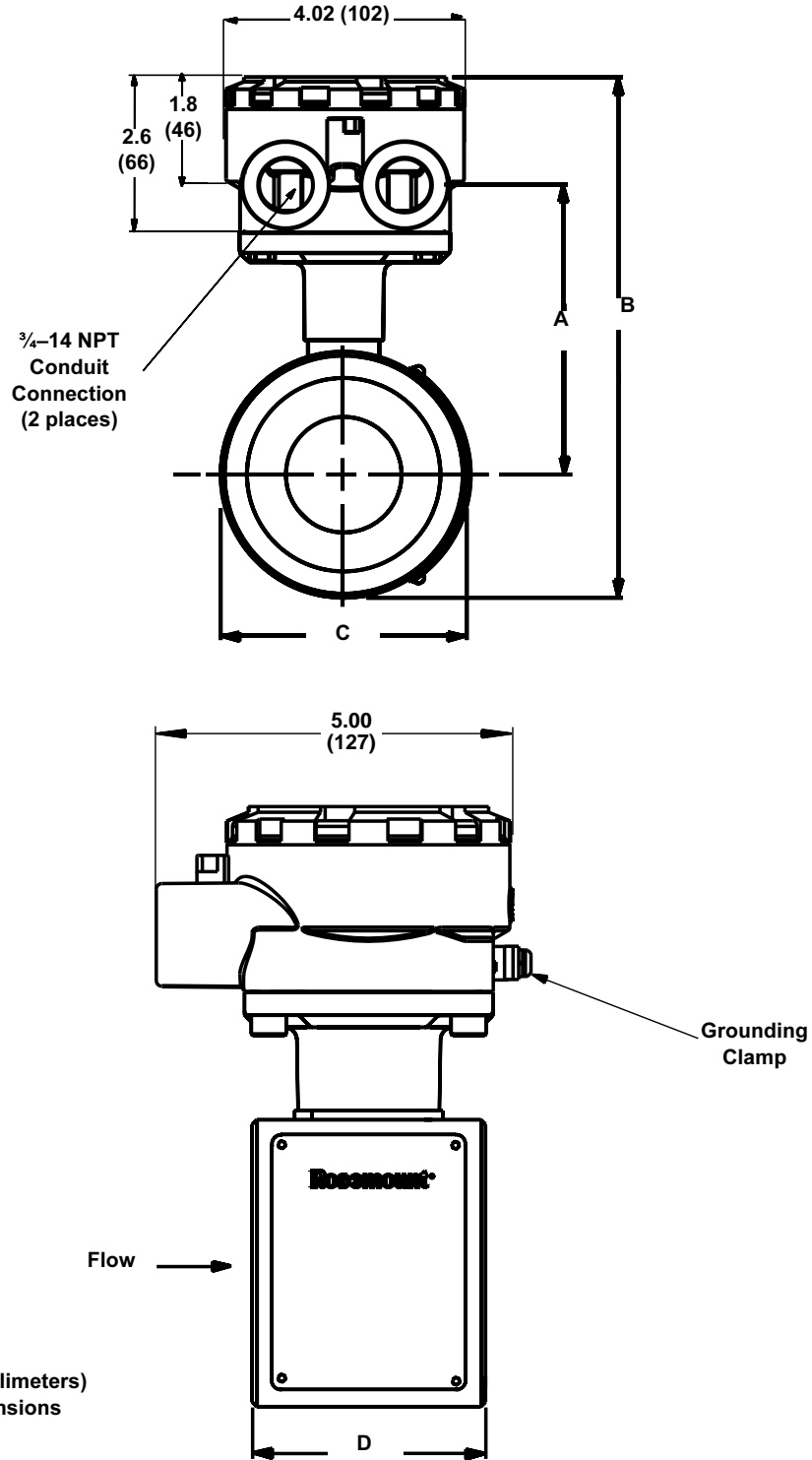

NOTE
 Dimensions are in inches (millimeters)
 See Table 8 for variable dimensions

8711-1012B04B, 1012A04B

Model 8711 Dimensional Drawings (0.15-inch through 1-inch line sizes)

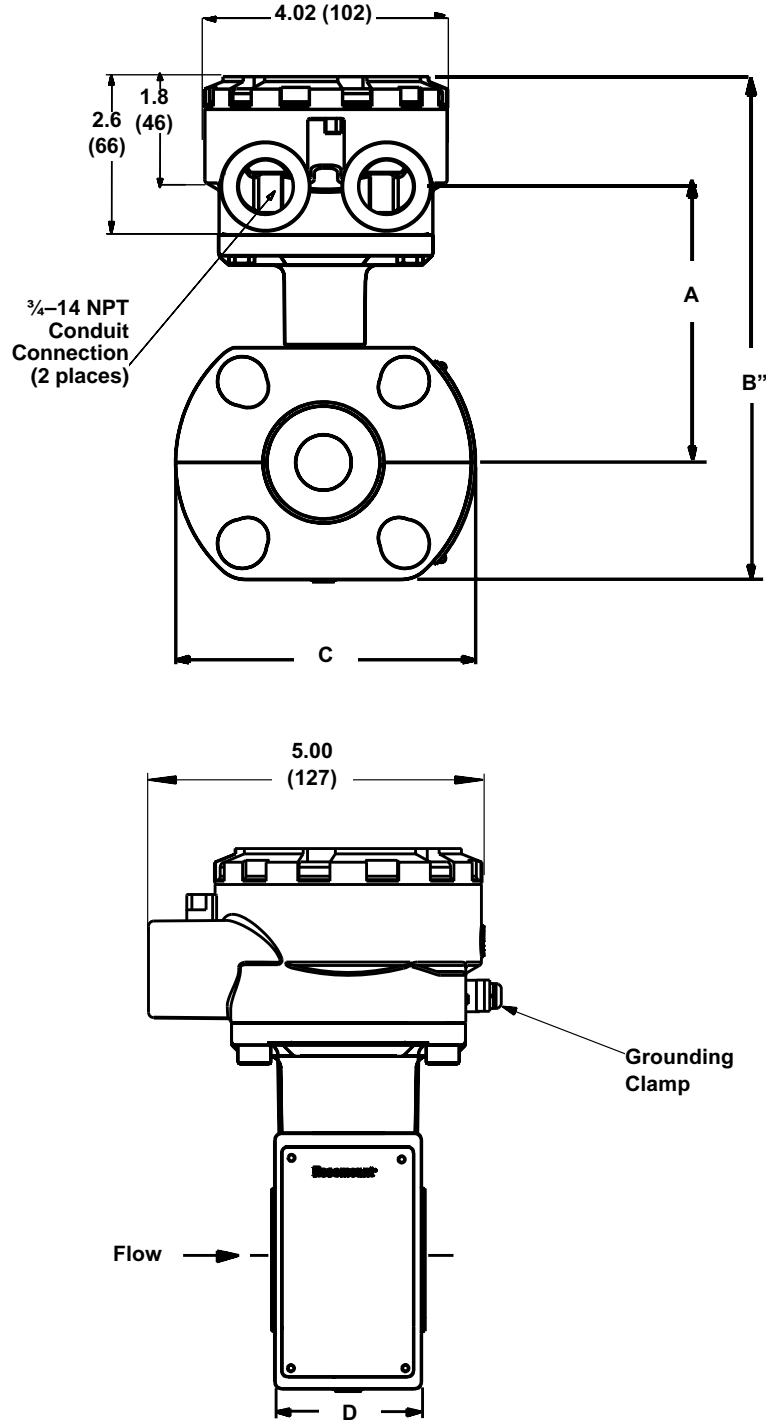

NOTE
Dimensions are in inches (millimeters)
See Table 8 for variable dimensions

8711-1012B03B, 1012A03B

Model 8714D is shipped with both the Model 8712C/U and Model 8732C Connector Types

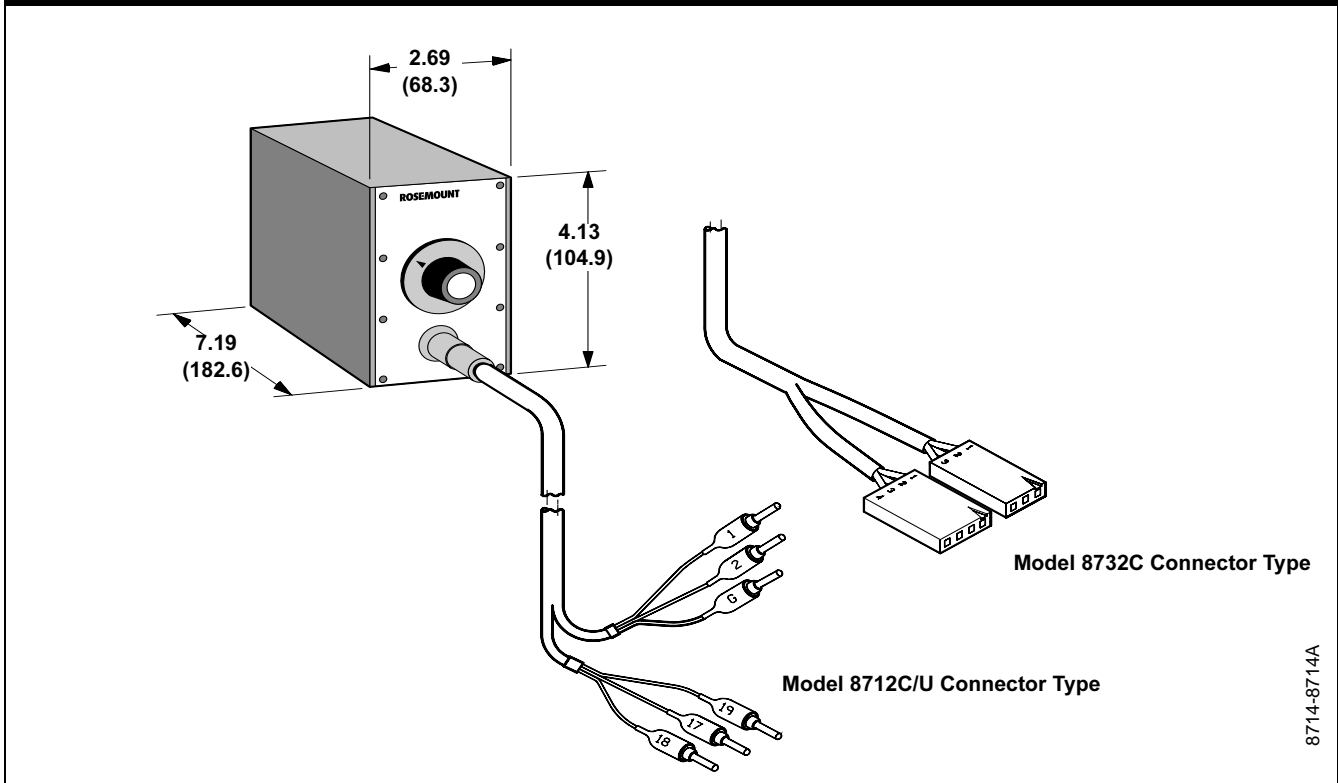

Magnetic Flowmeter Sizing

Flowmeter Sizing

Because of its effect on flow velocity, flowtube size is an important consideration. It may be necessary to select a magnetic flowmeter that is larger or smaller than the adjacent piping to ensure the fluid velocity is in the specified measuring range of the flowtube. Suggested guidelines and examples for sizing normal velocities in different applications are listed in Table 9, Table 10, and Table 11. Operation outside these guidelines may also give acceptable performance.

TABLE 9. Sizing Guidelines

Application	Velocity Range (ft/s)	Velocity Range (m/s)
Normal Service	2–20	0.6–6.1
Abrasive Slurries	3–10	0.9–3.1
Non-Abrasive Slurries	5–15	1.5–4.6

To convert flow rate to velocity, use the appropriate factor listed in Table 9 and the following equation:

$$\text{Velocity} = \frac{\text{Flow Rate}}{\text{Factor}}$$

Example: SI Units

Magnetometer Size: 100 mm (**factor from Table 10 = 492.0**)
 Normal Flow Rate: 800 L/min

$$\text{Velocity} = \frac{800 \text{ (L/min)}}{492.0}$$

Velocity = 1.7 m/s

Example: English Units

Magnetometer Size: 4 inch (**factor from Table 10 = 39.679**)
 Normal Flow Rate: 300 GPM

$$\text{Velocity} = \frac{300 \text{ (gpm)}}{39.679}$$

Velocity = 7.56 ft/s

TABLE 10. Line Size vs. Conversion Factor

Nominal Line Size Inches (mm)	Gallons Per Minute Factor	Liters Per Minute Factor
0.15 (4)	0.055	0.683
0.30 (8)	0.220	2.732
½ (15)	0.947	11.745
1 (25)	2.693	33.407
1½ (40)	6.345	78.69
2 (50)	10.459	129.7
3 (80)	23.042	285.7
4 (100)	39.679	492.0
6 (150)	90.048	1,116
8 (200)	155.94	1,933
10 (250)	245.78	3,048
12 (300)	352.51	4,371
14 (350)	421.70	5,229
16 (400)	550.80	6,830
18 (450)	697.19	8,645
20 (500)	866.51	10,745
24 (600)	1,253.2	15,541
30 (750)	2,006.0	24,877
36 (900)	2,935.0	36,398

TABLE 11. Line Size vs. Velocity/Rate

Nominal Line Size in Inches (mm)	Minimum/Maximum Flow Rate							
	Gallons per Minute				Liters per Minute			
	at .04 ft/s (Low-flow Cutoff)	at 1 ft/s (Min Range Setting)	at 3 ft/s	at 30 ft/s (Max Range Setting)	at .012 m/s (Low-flow Cutoff)	at 0.3 m/s (Min Range Setting)	at 1 m/s	at 10 m/s (Max Range Setting)
.15 (4)	0.002	0.055	0.16	1.65	0.01	0.21	0.68	6.83
.30 (8)	0.009	0.220	0.66	6.60	0.03	0.83	2.73	27.32
1/2 (15)	0.038	0.947	2.84	28.412	0.14	3.58	11.74	117.45
1 (25)	0.108	2.694	8.08	80.813	0.41	10.18	33.40	334.07
1 1/2 (40)	0.254	6.345	19.03	190.36	0.96	23.98	78.69	786.9
2 (50)	0.418	10.459	31.37	313.77	1.58	39.54	129.7	1,297
3 (80)	0.922	23.042	69.12	691.26	3.49	87.10	285.7	2,857
4 (100)	1.588	36.679	119.0	1,190.4	6.00	138.6	492.0	4,920
6 (150)	3.600	90.048	270.1	2,701.4	13.61	340.3	1,116	11,167
8 (200)	6.240	155.94	467.7	4,677.8	23.59	589.4	1,933	19,337
10 (250)	9.840	245.78	737.3	7,373.4	37.20	929.0	3,048	30,480
12 (300)	14.200	352.51	1,059	10,575	53.68	1,332	4,371	43,715
14 (350)	16.800	421.70	1,265	12,651	63.50	1,594	5,230	52,296
16 (400)	22.000	550.80	1,652	16,524	83.16	2,082	6,830	68,304
18 (450)	27.800	697.19	2,091	20,916	105.0	2,635	8,646	86,459
20 (500)	34.600	866.51	2,599	25,995	130.7	3,275	10,740	107,457
24 (600)	50.200	1,253.2	3,759	37,596	189.7	4,737	15,540	155,414
30 (750)	80.200	2,006.0	6,018	60,180	303.1	7,582	24,880	248,773
36 (900)	117.40	2,935.0	8,805	88,050	443.7	11,094	36,390	363,983

Upstream/Downstream Piping Length

To ensure specification accuracy over widely varying process conditions, install the flowtube with a minimum of five straight pipe diameters upstream and two straight pipe diameters downstream from the electrode plane. See Figure 1. This procedure should adequately allow for disturbances created by elbows, valves, and reducers.

FIGURE 1. Upstream and Downstream Straight Pipe Diameters

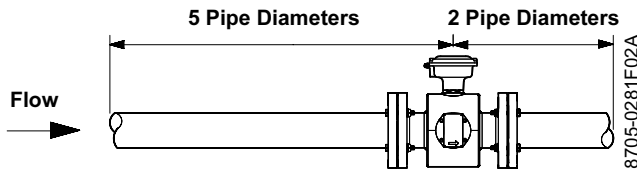

Flowtube Grounding

A reliable ground path is required between the flowtube and the process fluid. Optional grounding rings, grounding electrodes, and lining protectors are available with Series 8700 flowtubes to ensure proper grounding. See Table 12 and Table 13.

TABLE 12. Grounding Options

Grounding Options	General Characteristics
No Grounding Options (grounding straps)	<ul style="list-style-type: none"> Acceptable for conductive unlined pipe Grounding straps provided by Rosemount Inc.
Grounding Electrode	<ul style="list-style-type: none"> Same material as measurement electrodes Sufficient grounding option when process fluid conductivity is greater than 100 microsiemens/cm
Grounding Rings	<ul style="list-style-type: none"> Low conductivity process fluids Cathodic or electrolysis applications that may have stray currents in or around the process Variety of materials for process fluid compatibility
Lining Protectors	<ul style="list-style-type: none"> Protects upstream edge of flowtube from abrasive fluids Permanently installed on flowtube Protects liner material from over torquing of flange bolts Provides ground path and eliminates need for grounding ring or grounding electrode

Product Data Sheet

00813-0100-4727, Rev HA
January 2002

Series 8700

TABLE 13. Grounding Installation

Type of Pipe	Grounding Options			
	No Grounding Options	Grounding Rings	Grounding Electrodes	Lining Protectors
Conductive Unlined Pipe	Acceptable	Not Required	Not Required	Acceptable
Conductive Lined Pipe	Not Acceptable	Acceptable	Acceptable	Acceptable
Non-Conductive Pipe	Not Acceptable	Acceptable	Acceptable	Acceptable

Material Selection

Several liner types, electrode materials, and electrode types are available on Rosemount Magnetic Flowtubes to ensure compatibility with virtually any application. See Table 14 for information on liner types, Table 15 for information on electrode materials, and Table 16 for information on electrode types. For further guidance on selecting materials, refer to the Magnetic Flowmeter Material Selection Guide located on Rosemount.com (document number 00816-0100-3033).

TABLE 14. Lining Material

Lining Material	General Characteristics
Teflon (PTFE)	<ul style="list-style-type: none"> Highly chemical-resistant Excellent high temperature capabilities
Tefzel (ETFE)	<ul style="list-style-type: none"> Highly chemical-resistant Better abrasion resistance than Teflon
Polyurethane	<ul style="list-style-type: none"> Excellent abrasion resistance Limited chemical resistance
Neoprene	<ul style="list-style-type: none"> Very good abrasion resistance Better chemical resistance than polyurethane
Linatex Rubber	<ul style="list-style-type: none"> Very good abrasion resistance Limited chemical resistance especially in acids Softer material than polyurethane and neoprene

TABLE 15. Electrode Material

Electrode Material	General Characteristics
316L Stainless Steel	<ul style="list-style-type: none"> Good corrosion resistance Good abrasion resistance Not recommended for sulfuric or hydrochloric acids
Hastelloy C-276	<ul style="list-style-type: none"> Better corrosion resistance High strength Good in slurry applications Effective in oxidizing fluids
Tantalum	<ul style="list-style-type: none"> Better chemical resistance Not recommended for hydrofluoric acid, fluosilic acid, or sodium hydroxide
90% Platinum - 10% Iridium	<ul style="list-style-type: none"> Best chemical resistance Expensive material Not recommended for aqua regia
Titanium	<ul style="list-style-type: none"> Better chemical resistance Better abrasion resistance Good for sea water applications Not recommended for hydrofluoric or sulfuric acid

TABLE 16. Electrode Type

Electrode Type	General Characteristics
Standard Measurement	<ul style="list-style-type: none"> Costs least Good for most applications
Bulletnose Electrodes	<ul style="list-style-type: none"> Slightly more expensive Best option for coating processes
Removable Electrode	<ul style="list-style-type: none"> Most expensive Better than standard electrode for coating processes

Ordering Information

MODEL 8712C/U/H ORDERING INFORMATION

Model	Product Description	Availability		
		C	U	H
8712C	Magnetic Flowmeter Transmitter	•	NA	NA
8712U	Universal Magnetic Flowmeter Transmitter	NA	•	NA
8712H	High-Signal Magnetic Flowmeter Transmitter (For use with Model 8707 High-Signal Flowtube only.)	NA	NA	•
Code	Transmitter Style	C	U	H
R	Remote (2-inch pipe or surface mounting)	•	•	•
Code	Power Supply Voltage	C	U	H
03	10–30 V dc	•	•	NA
12	115 V ac, 50–60 Hz	•	•	•
24	230 V ac, 50–60 Hz	•	•	NA
Code	Hazardous Location Certifications	C	U	H
N0	Factory Mutual (FM) Class I, Division 2 Approval for nonflammable fluids; Canadian Standards Association (CSA) Class I, Division 2 Approval	•	•	•
N5	Factory Mutual (FM) Class I, Division 2 Approval for flammable fluids	•	•	NA
CE	CE Marking	•	•	NA
Code	Options	C	U	H
B6	Stainless Steel 4-bolt Kit for 2-inch Pipe Mount	•	•	•
C1	Custom Configuration (Completed CDS required with order)	•	•	•
C4	Analog Output Levels Compliant with NAMUR recommendations NE43, 18-January-1994, and high alarm level ⁽¹⁾	•	•	NA
CN	Analog Output Levels Compliant with NAMUR recommendations NE43, 18-January-1994, and low alarm level ⁽¹⁾	•	•	NA
D1	High Accuracy Calibration [0.25% of rate from 3 to 30 ft/s (0.9 to 10 m/s)] matched flowtube and transmitter system ⁽²⁾	•	NA	NA
M4	Local Operator Interface (LOI)	•	•	•
T1	Battery-backed Totalizer	•	•	NA
Typical Model Number: 8712C R 12 N0 M4				

(1) NAMUR compliant operation and the Alarm latch options are preset at the factory and can not be changed to standard operation in the field.

(2) Option Code must be selected for both flowtube and transmitter.

MODEL 8732C ORDERING INFORMATION

Model	Product Description	Availability
8732C	Magnetic Flowmeter Transmitter	•
Code	Transmitter Style	
T	Integral (mounted to flowtube)	•
R	Remote (2-inch pipe mount) ⁽¹⁾	
Code	Power Supply Voltage	
03	15–30 V dc	•
12	85–250 V ac, 50–60 Hz	•
Code	Hazardous Location Certifications	
N0	Factory Mutual (FM) Class I, Division 2 Approval for nonflammable fluids; Canadian Standards Association (CSA) Class I, Division 2 Approval; KEMA/CENELEC Ex nL IIB ⁽¹⁾ CE Marking	•
N5	Factory Mutual (FM) Class I, Division 2 Approval for flammable fluids	•
E5	Factory Mutual (FM) Class I, Division 1, Explosion Proof Approval	•
ED	KEMA/CENELEC EEx d II BT6 Increased Safety Approval; CE Marking	•
Code	Options	
C1	Custom Configuration – Completed CDS required with order	•
C4	Analog Output Levels Compliant with NAMUR recommendations NE43, 18-January-1994, and high alarm level ⁽²⁾	•
CN	Analog Output Levels Compliant with NAMUR recommendations NE43, 18-January-1994, and low alarm level ⁽¹⁾	•
D1	High Accuracy Calibration [0.25% of rate from 3 to 30 ft/s (0.9 to 10 m/s)] matched flowtube and transmitter system ⁽³⁾	•
J1	CM 20 Conduit Adaptor	•
J2	PG 13.5 Conduit Adaptor	•
L1	Transient Protection Circuitry	•
M4	Local Operator Interface	•
T1	Non-volatile Totalizer	•
Typical Model Number: 8732C T 12 N0 M4		

(1) Pending Approval, consult factory for availability

(2) NAMUR compliant operation and the Alarm latch options are preset at the factory and can not be changed to standard operation in the field.

(3) Option Code must be ordered for both flowtube and transmitter.

Series 8700

MODEL 8705 ORDERING INFORMATION

Code	Product Description	Availability		
8705	Magnetic Flowmeter Flowtube	•		
Code	Lining Material			
T	<i>Teflon</i> (PTFE)	•		
F	<i>Tefzel</i> (ETFE) (available in ½- to 16-inch (15 to 400 mm) line sizes)	•		
P	Polyurethane (available in 1½- to 36-inch (40 to 900 mm) line sizes)	•		
N	Neoprene (available in 1½- to 36-inch (40 to 900 mm) line sizes)	•		
L	Linatex natural rubber (available in 1½- to 36-inch (40 to 900 mm) line sizes)	•		
Other lining materials available upon request. Consult factory.		•		
Code	Electrode Material / Electrode Type			
Two Measurement Electrodes				
SA	316L Stainless Steel	•		
HA	<i>Hastelloy C-276</i>	•		
TA	Tantalum	•		
PA	90% Platinum—10% Iridium	•		
NA	Titanium	•		
Two Measurement Electrodes + Third Grounding Electrode (Not available with W3 on electrode housing configuration on 8" (200 mm) and under line sizes.)				
SE	316L Stainless Steel	•		
HE	<i>Hastelloy C-276</i>	•		
TE	Tantalum	•		
PE	90% Platinum—10% Iridium	•		
NE	Titanium	•		
Two Bulletnose Measurement Electrodes (Not available in 0.5 - 1.5 in (15 - 40 mm) line sizes.)				
SB	316L Stainless Steel	•		
HB	<i>Hastelloy C-276</i>	•		
Two Removable Measurement Electrodes (Not available in ½- and 1-inch (14 and 25 mm) line sizes); requires W3 option				
SR	316L Stainless Steel	•		
HR	<i>Hastelloy C-276</i>	•		
Other electrode materials and types available upon request. Consult factory.				
		Lining Material (from above)		
Code	Line Size	Code T	Code F	Code P, N, and L
005	½ inch (15 mm)	•	•	NA
010	1 inch (25 mm)	•	•	NA
015	1½ inch (40 mm)	•	•	•
020	2 inch (50 mm)	•	•	•
030	3 inch (80 mm)	•	•	•
040	4 inch (100 mm)	•	•	•
060	6 inch (150 mm)	•	•	•
080	8 inch (200 mm)	•	•	•
100	10 inch (250 mm)	•	•	•
120	12 inch (300 mm)	•	•	•
140	14 inch (350 mm)	•	•	•
160	16 inch (400 mm)	•	•	•
180	18 inch (450 mm)	•	NA	•
200	20 inch (500 mm)	•	NA	•
240	24 inch (600 mm)	•	NA	•
300	30 inch (750 mm)	•	NA	•
360	36 inch (900 mm)	•	NA	•

Continued on Next Page

Product Data Sheet

00813-0100-4727, Rev HA

January 2002

Series 8700

Code	Flange Material, Type, and Rating	Availability
C1	Carbon Steel, ASME B16.5 (ANSI) Class 150 (30- and 36-inch AWWA C207 Table 2 Class D Flat Face)	•
C3	Carbon Steel, ASME B16.5 (ANSI) Class 300	•
C6	Carbon Steel, ASME B16.5 (ANSI) Class 600 ⁽¹⁾ (maximum pressure: 1000 psig; available in 0.5- through 10-inch [15 through 250 mm])	•
C7	Carbon Steel, ASME B16.5 (ANSI) Class 600 ⁽²⁾ (with lining material codes P, N, and L only; available in 1.5- through 8-inch [40 through 200 mm])	•
S1	304 Stainless Steel, ASME B16.5 (ANSI) Class 150 (30- and 36-inch AWWA C207 Table 2 Class D Flat Face)	•
S3	304 Stainless Steel, ASME B16.5 (ANSI) Class 300	•
S6	304 Stainless Steel, ASME B16.5 (ANSI) Class 600 ⁽¹⁾ (maximum pressure: 1000 psig; available in 0.5- through 10-inch [15 through 250 mm])	•
S7	304 Stainless Steel, ASME B16.5 (ANSI) Class 600 ⁽²⁾ (lining material codes P, N, and L only; available in 1.5- through 8-inch [40 through 200 mm])	•
P1	316 Stainless Steel, ASME B16.5 (ANSI) Class 150 (30- and 36-inch AWWA C207 Table 2 Class D Flat Face), pipe and flange	•
P3	316 Stainless Steel, ASME B16.5 (ANSI) Class 300, pipe and flange	•
CD	Carbon Steel, DIN PN 10 (not available for flange sizes 15 to 150 mm)	•
CE	Carbon Steel, DIN PN 16 (not available for flange sizes 15 to 80 mm)	•
CF	Carbon Steel, DIN PN 25 (not available for flange sizes 15 to 150 mm)	•
CH	Carbon Steel, DIN PN 40 (not available for flange sizes 750 to 900 mm)	•
SD	Stainless Steel, DIN PN 10 (not available for flange sizes 15 to 150 mm)	•
SE	Stainless Steel, DIN PN 16 (not available for flange sizes 15 to 80 mm)	•
SF	Stainless Steel, DIN PN 25 (not available for flange sizes 15 to 150 mm)	•
SH	Stainless Steel, DIN PN 40 (not available for flange sizes 750 to 900 mm)	•

Other flange materials, types, and ratings available upon request. Consult factory.

Code	Electrode Housing Configuration	
W0	Sealed, welded housing	•
W1	Sealed, welded housing with pressure relief	•
W3	Sealed, welded housing with separate electrode compartments	•

Code	Hazardous Location Certifications	
N0	Factory Mutual (FM) Class I, Division 2 Approval for nonflammable fluids; Canadian Standards Association (CSA) Class I, Division 2 Approval, KEMA/CENELEC Ex nL IIB ⁽³⁾ CE Marking	•
N5	Factory Mutual (FM) Class I, Division 2 Approval for flammable fluids	•
KD	KEMA/CENELEC EEx e ia IIC Approval CE Marking	•

Code	Options	
Optional Grounding Rings⁽⁴⁾		
G1	316L SST Grounding Rings	•
G2	Hastelloy C-276 Grounding Rings (0.5- to 12-inch (15 to 300 mm) flowtube line sizes)	•
G3	Titanium Grounding Rings (0.5- to 12-inch (15 to 300 mm) flowtube line sizes)	•
G4	Tantalum Grounding Rings (0.5- to 8-inch (15 to 200 mm) flowtube line sizes)	•
G5	Single 316L SST Grounding Ring	•
G6	Single Hastelloy C-276 Grounding Ring (0.5- to 12-inch (15 to 300 mm) flowtube line sizes)	•
G7	Single Titanium Grounding Ring (0.5- to 12-inch (15 to 300 mm) flowtube line sizes)	•
G8	Single Tantalum Grounding Ring (0.5- to 8-inch (15 to 200 mm) flowtube line sizes)	•

Continued on Next Page

Series 8700

Code	Options Continued	
Optional Lining Protectors⁽⁴⁾		
L1	316L SST Lining Protectors	•
L2	Hastelloy C-276 Lining Protectors (0.5- to 12-inch (15 to 300 mm) flowtube line sizes)	•
L3	Titanium Lining Protectors (0.5- to 12-inch (15 to 300 mm) flowtube line sizes)	•
Optional Sanitary Connections⁽⁵⁾		
A3	Sanitary 3-A (0.5- to 3-inch (15 to 80 mm) sizes only); ASME B16.5 (ANSI) Class 150 to Tri-Clamp Adapter	•
A4	Sanitary 3-A (2.5-inch (64 mm) sizes only); ASME B16.5 (ANSI) Class 150 to Tri-Clamp Adapter	•
A5	Cherry Burrell Sanitary I-line (0.5- to 3-inch (15 to 80 mm) sizes only); ASME B16.5 (ANSI) Class 150 to I-line Adapter	•
A6	Cherry Burrell Sanitary I-line (2.5-inch (64 mm) sizes only); ASME B16.5 (ANSI) Class 150 to I-Line Adapter	•
Other Options		
B3	Integral Mount with Model 8732C/8742C Transmitter	•
D1	High Accuracy Calibration [0.25% of rate from 3-30 ft/s (0.9-10 m/s)] matched flowtube and transmitter system ⁽⁶⁾	•
DW	NSF Drinking Water Certification (PTFE Teflon or ETFE Tefzel liners only)	•
H1	Model 8701 flowtube lay length (available for 0.5- to 4-inch (15 to 100 mm) line sizes); spool piece: ASME B16.5 (ANSI) Class 150 or Class 300 flange and 304 stainless steel pipe	•
H2	Model 8701 Flowtube lay length (available for 0.5- to 16-inch (15-400 mm) line sizes.)	•
H5	Foxboro [®] Model 2800 lay length (available for 3.0 to 18 inch (80 to 450mm line sizes)) spool piece: ASME B16.5 (ANSI) Class 150 flange and 304 stainless steel pipe.	•
H7	ABB Fisher & Porter [®] Model CopgX and MagX lay length (available for 0.5 to 12in (15 to 3000 mm line sizes)) spool piece: ASME B16.5 (ANSI) Class 150 flange and 304 stainless steel pipe or teflon spacer.	•
Q4	Inspection Certificate for Calibration Data Consistent with ISO 10474 3.1.B	•
Q5	Hydrostatic Testing Certification	•
Q8	Material Traceability Certificate per DIN 3.1 B	•
Q9	Material Traceability Certificate (electrodes only) per DIN 3.1B 337	•
Q66	Welding Procedure Qualification Record Documentation	•
Q67	Welder Performance Qualification Record Documentation	•
Q68	Welding Procedure Specification Documentation	•
Q70	Inspection Certificate Weld Examination, ISO 10474 3.1.B	
	– 0.5- to 12-inch [15-300 mm] flowtube line sizes	•
	– 14- to 18-inch [350-450 mm] flowtube line sizes	•
	– 20- to 36-inch [500-900 mm] flow tube line sizes	•
Typical Model Number: 8705 T SA 040 C1 W0 N0		

(1) Electrode options limited to two measurement electrodes or two measurement electrodes + third grounding electrode.

(2) Electrode options limited to two stainless steel or two Hastelloy C-276 measurement electrodes only.

(3) Pending approval, consult factory for availability

(4) Grounding Rings and Lining Protectors provide the same fluid grounding function. Lining Protectors available in Teflon (PTFE) and Tefzel (ETFE) only.

(5) Sealed, welded housing (Option Code W0 or W1) required. Only available with Teflon (PTFE) lining material (Option Code T) and 316L Stainless Steel, Hastelloy C-276, and 90% Platinum-10% Iridium electrode material (Option Codes S, H, and P). Not available with integral mount Model 8712 transmitter. Sanitary connection codes A4 and A6 only available in line size code 020.

(6) Option Code must be ordered for both flowtube and transmitter.

Product Data Sheet

00813-0100-4727, Rev HA

January 2002

Series 8700

MODEL 8707 ORDERING INFORMATION

Code	Product Description	Availability		
8707	High-Signal Magnetic Flowmeter Flowtube	•		
Code	Lining Material			
T	Teflon (PTFE)	•		
F	Tefzel (ETFE) (available in 3- to 16-inch (80 to 400 mm) line sizes.)	•		
P	Polyurethane	•		
N	Neoprene	•		
L	Linatex natural rubber	•		
Other lining materials available upon request. Consult factory.				
Code	Electrode Material / Electrode Type			
Two Measurement Electrodes				
SA	316L Stainless Steel	•		
HA	Hastelloy C-276	•		
TA	Tantalum	•		
PA	90% Platinum —10% Iridium	•		
NA	Titanium	•		
Two Bullethead Measurement Electrodes				
SB	316L Stainless Steel	•		
HB	Hastelloy C-276	•		
Lining Material (from above)				
Code	Line Size	Code T	Code F	Code P, N, and L
030	3 inch (80 mm)	•	•	•
040	4 inch (100 mm)	•	•	•
060	6 inch (150 mm)	•	•	•
080	8 inch (200 mm)	•	•	•
100	10 inch (250 mm)	•	•	•
120	12 inch (300 mm)	•	•	•
140	14 inch (350 mm)	•	•	•
160	16 inch (400 mm)	•	•	•
180	18 inch (450 mm)	•	NA	•
200	20 inch (500 mm)	•	NA	•
240	24 inch (600 mm)	•	NA	•
300	30 inch (750 mm)	•	NA	•
360	36 inch (900 mm)	•	NA	•
Code	Flange Material, Type, and Rating			
C1	Carbon Steel, ASME B16.5 (ANSI) Class 150 (30- and 36-inch AWWA C207 Table 2 Class D Flat Face)	•		
C3	Carbon Steel, ASME B16.5 (ANSI) Class 300	•		
S1	304 Stainless Steel, ASME B16.5 (ANSI) Class 150 (30- and 36-inch AWWA C207 Table 2 Class D Flat Face)	•		
S3	304 Stainless Steel, ASME B16.5 (ANSI) Class 300	•		
Code	Housing Configuration			
W0	Sealed, welded housing	•		
W1	Sealed, welded housing with pressure relief	•		
W3	Sealed, welded housing with separate electrode compartments (only available with line size codes 300 and 360)	•		
Code	Hazardous Location Certifications			
N0	Factory Mutual (FM) Class I, Division 2 Approval for nonflammable fluids; Canadian Standards Association (CSA) Class I, Division 2 Approval	•		

Continued on Next Page

Series 8700

Code	Options	Availability
	Optional Grounding Rings⁽¹⁾	
G1	316L SST Grounding Rings	•
G2	<i>Hastelloy</i> C-276 Grounding Rings (3- to 12-inch (80 to 300 mm) flowtube line sizes)	•
G3	Titanium Grounding Rings (3- to 12-inch (80 to 300 mm) flowtube line sizes)	•
G4	Tantalum Grounding Rings (3- to 8-inch (80 to 200 mm) flowtube line sizes)	•
G5	Single 316L SST Grounding Ring	•
G6	Single <i>Hastelloy</i> C-276 Grounding Ring (0.5- to 12-inch (15 to 300 mm) flowtube line sizes)	•
G7	Single Titanium Grounding Ring (0.5- to 12-inch (15 to 300 mm) flowtube line sizes)	•
G8	Single Tantalum Grounding Ring (0.5- to 8-inch (15 to 200 mm) flowtube line sizes)	•
	Optional Lining Protectors⁽¹⁾	
L1	316L SST Lining Protectors	
L2	<i>Hastelloy</i> C-276 Lining Protectors (3- to 12-inch (80 to 300 mm) flowtube line sizes)	•
L3	Titanium Lining Protectors (3- to 12-inch (80 to 300 mm) flowtube line sizes)	•
	Other Options	
D1	High Accuracy Calibration [0.25% of rate from 3-30 ft/s (0.9-10 m/s)] matched flowtube and transmitter system ⁽²⁾	•
D2	Dual Flowtube Calibration Numbers on Model 8712H and Model 8712C Transmitters	•
H1	Model 8703 flowtube lay length (available for 3- to 4-inch (80 to 100 mm) line sizes); spool piece: ASME B16.5 (ANSI) Class 150 or Class 300 flange and 304 stainless steel pipe	•
H2	Model 8703 flowtube lay length (available for 3- to 16-inch (80 to 400 mm) line sizes)	•
H5	Foxboro [®] Model 2800 lay length (available for 3.0 to 18 inch (80 to 450mm line sizes)) spool piece: ASME B16.5 (ANSI) Class 150 flange and 304 stainless steel pipe.	•
H7	ABB Fisher & Porter [®] Model CopgX and MagX lay length (available for 0.5 to 12in (15 to 3000 mm line sizes)) spool piece: ASME B16.5 (ANSI) Class 150 flange and 304 stainless steel pipe or teflon spacer.	•
Q4	Inspection Certificate for Calibration Data Consistent with ISO 10474 3.1.B	•
Q5	Hydrostatic Testing Certification	•
Q8	Material Traceability Certificate per DIN 3.1 B	•
Q9	Material Traceability Certificate (electrodes only) per DIN 3.1B 337	•
Q66	Welding Procedure Qualification Record Documentation	•
Q67	Welder Performance Qualification Record Documentation	•
Q68	Welding Procedure Specification Documentation	•
Q70	Inspection Certificate Weld Examination, ISO 10474 3.1.B	
	– 3- to 12-inch [80-300 mm] flowtube line sizes	•
	– 14- to 18-inch [350-450 mm] flowtube line sizes	•
	– 20- to 36-inch [500-900 mm] flow tube line sizes	•
Typical Model Number: 8707 T SA 040 C1 W0 N0		

(1) Grounding Rings and Lining Protectors provide the same fluid grounding function. Lining Protectors available with Teflon (PTFE) and Tefzel (ETFE) lining material only.

(2) Option Code must be ordered for both flowtube and transmitter.

MODEL 8711 ORDERING INFORMATION

Model	Product Description	Availability
8711	Magnetic Flowmeter Flowtube (flangeless construction)	•
Code	Lining Material	
T	Tefzel (ETFE)	•
S	Teflon (PTFE) (not available with 0.15 and 0.30 inch [4 and 8 mm] line sizes)	•
Code	Electrode Material / Electrode Type	
Two Measurement Electrodes		
SA	316L Stainless Steel	•
HA	<i>Hastelloy C-276</i>	•
TA	Tantalum	•
PA	90% Platinum—10% Iridium	•
NA	Titanium	•
Two Measurement Electrodes + Third Grounding Electrode		
SE	316L Stainless Steel	•
HE	<i>Hastelloy C-276</i>	•
TE	Tantalum	•
PE	90% Platinum—10% Iridium	•
NE	Titanium	•
Code	Line Size	
15F	0.15 inch (4 mm) (not available with <i>Teflon</i> (PTFE) lining material)	•
30F	0.30 inch (8 mm) (not available with <i>Teflon</i> (PTFE) lining material)	•
005	½ inch (15 mm)	•
010	1 inch (25 mm)	•
015	1½ inch (40mm)	•
020	2 inch (50mm)	•
030	3 inch (80 mm)	•
040	4 inch (100 mm)	•
060	6 inch (150 mm)	•
080	8 inch (200 mm)	•
Code	Transmitter Mounting Configuration	
R	Remote	•
U	Integral, mounted to Model 8732C/8742C transmitter	•
Continued on Next Page		

Series 8700

Code	Mounting Kit	Availability
	Expanded Kit: includes two alignment rings (where applicable), threaded SST studs, and nuts	
1	ASME B16.5 (ANSI) Class 150	•
2	DIN PN 10/16 (8 inch [200 mm] has a PN 10 mounting kit only)	•
3	ASME B16.5 (ANSI) Class 300	•
4	DIN PN 25/40 (8 inch [200 mm] has a PN 25 mounting kit only)	•
	Standard Kit: includes two alignment rings (where applicable)	
5	ASME B16.5 (ANSI) Class 150	•
6	DIN PN 10/16 (8 inch [200 mm] has a PN 10 alignment rings only)	•
7	ASME B16.5 (ANSI) Class 300	•
8	DIN PN 25/40 (8 inch [200 mm] has a PN 25 alignment rings only)	•
Code	Hazardous Location Certifications	
N0	Factory Mutual (FM) Class I, Division 2 Approval for nonflammable fluids; Canadian Standards Association (CSA) Class I, Division 2 Approval; KEMA/CENELEC Ex nL IIB ⁽¹⁾ CE Marking	•
N5	Factory Mutual (FM) Class 1, Division 2 Approval for flammable fluids	•
E5	Factory Mutual (FM) Class 1, Division 1, Explosion-Proof Approval (available with integral mount Model 8732C or remote mount transmitters)	•
CD	KEMA/CENELEC EEx e ia IIC Increased Safety Approval; CE Marking	•
Code	Options	
DW	NSF Drinking Water Certification	•
G1	316L SST Grounding Rings	•
G2	Hastelloy C-276 Grounding Rings	•
G3	Titanium Grounding Rings	•
G4	Tantalum Grounding Rings	•
Q4	Inspection Certificate for Calibration Data Consistent with ISO 10474 3.1.B	•
Q5	Hydrostatic Testing Certification	•
Q8	Material Traceability Certificate per DIN 3.1B	•
Q9	Material Traceability Certificate (Electrodes only) per DIN 3.1B	•
Q66	Welding Procedure Qualification Record Documentation (6- to 8-inch (150- to 200mm) line sizes only)	•
Q67	Welder Performance Qualification Record Documentation	•
Q68	Welding Procedure Specification Documentation	•
Q70	Inspection Certificate Weld Examination, ISO 10474 3.1.B – .15 to 8-inch [4-300 mm] flowtube line sizes	•
Typical Model Number: 8711 T SA 030 U 5 N0		

(1) Pending Approval, consult factory for availability

MODEL 8714 DQ4 ORDERING INFORMATION

Model	Description	Availability
8714DQ4	Reference Calibration Standard	•

Product Data Sheet

00813-0100-4727, Rev HA
January 2002

Series 8700

Tagging

The flowtube and transmitter will be tagged, at no charge, in accordance with customer requirements.

Standard SST tag is wired to the transmitter. Tag character height is 0.125 in. (3.18 mm); 85 characters maximum.

Tag may be permanently stamped on flowtube and/or transmitter nameplate upon request; 65 characters maximum.

Ordering Procedure

To order, select the desired flowtube and/or transmitter by specifying model codes from the ordering table.

For remote transmitter applications, note the cable specification requirements.

Flowtubes and transmitters must be selected from Product Data Sheet 00813-0100-4727.

Standard Configuration

Unless the Configuration Data Sheet is completed, the transmitter will be shipped as follows:

Engineering Units:	ft/sec
4 mA (1 V dc):	0
20 mA (5 V dc):	30
Tube Size:	3-inch
Empty Pipe:	Off
Flowtube Calibration Number:	1000005010000000

The Model 8732C Transmitter is factory-calibrated with the attached flowtube size and appropriate calibration number.

Custom Configuration (Option Code C1)

If Option Code C1 is ordered, the Configuration Data Sheet (CDS) must be submitted at the time of order.

Rosemount Smart Family[®] Instruments

Rosemount SMART FAMILY instruments include pressure, temperature, level, and flow measurement.

All SMART FAMILY instruments are designed to communicate using HART (Highway Addressable Remote Transducer) protocol with the hand-held HART Communicator and Fisher-Rosemount Control Systems.

Product Data Sheet

00813-0100-4727, Rev HA
January 2002

Series 8700

*Rosemount and the Rosemount logotype are registered trademarks of Rosemount Inc.
PlantWeb is a mark of one of the Emerson Process Management companies.
All other marks are the property of their respective owners.
PlantWeb and DeltaV are trademarks of the Fisher-Rosemount Group of Companies.
HART is a registered trademark of the HART Communication Foundations.
Foundation is a trademark of the Fieldbus Foundation.
Hastelloy and Hastelloy C are registered trademarks of Haynes International.
Teflon and Tefzel are registered trademarks of E.I. du Pont de Nemours & Co.
Tri-Clamp is a registered trademark of Tri-Clover, Inc. of the Alfa-Laval Group.
Foxboro and I/A Series are registered trademarks of the Foxboro Company.
ABB Fisher & Porter is a registered trademark of the Fisher Company.
Cover Photo: Groups-010ac.tif*

Emerson Process Management

Rosemount Inc.

8200 Market Boulevard
Chanhassen, MN 55317 USA
T (U.S.) 1-800-999-9307
T (International) (952) 906-8888
F (952) 949-7001

www.rosemount.com



Fisher-Rosemount Flow

Groeneveldselaan 6-8
3903 AZ Veendaal
The Netherlands
Tel 31 (0) 318 549 549
Fax 31 (0) 318 549 559
Tel 0800-966 180 (U.K. only)
Fax 0800-966 181 (U.K. only)

Fisher-Rosemount Flow

Singapore Pte Ltd.
1 Pandan Crescent
Singapore 128461
Tel (65) 777-8211
Fax (65) 777-0947
AP.RMT-Specialist@emersonprocess.com



EMERSON[™]
Process Management