

MAGFLO®

Electromagnetic flowmeters

Sensor types MAG 1100, MAG 3100

Signal converter types MAG 5000, MAG 6000







SAP No.





5 2 1 H 0 7 2 3

DKIN.PS.027.W1.02

MAGFLO®
Danfoss range of electro-magnetic flowmeters

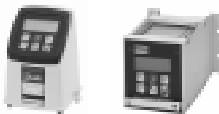
	MAG 1100 	MAG 1100 FOOD 	MAG 3100 	MAG 3100 W 
Size [mm]	DN 6-100	DN 10-100	DN 15-2000	DN 25-1200
Connection	Flangeless (Sandwich design)	Weld-in adapter, clamp adapter, thread adapter	Flange	Flange
Pressure [bar]	Max. 40	Max. 40	Max. 100	Max. 40
Temperature [°C]	-20 to 200	-30 to 150	-40 to 180	-10 to 95
Liner	Ceramic (Al ₂ O ₃)	Ceramic (Al ₂ O ₃) PFA	Neoprene, EPDM, Teflon (PTFE), Polyurethane, Ebonite, Linatex®	Neoprene and EPDM
Electrodes	Platinum	Platinum Hastelloy	AISI 316 Ti, Hastelloy C, Platinum/Iridium, Monel, Titanium, Tantalum	AISI 316 Ti Earthing electrode
Enclosure	IP 67	IP 67	IP 67 / 68	IP 67 / 68
Ex-version	EEx [ia/ib] IIB T4-T6		EEx [ia/ib] IIB T4-T6 EEx [ia/e] IIC T3-T6	

	MAG 5000 	MAG 6000 	MAG 3000 Ex-d 
Outputs	1 current output 1 digital output 1 relay output	1 current output 1 digital output 1 relay output	1 current output 1 frequency/pulse output 1 relay output
Flow direction	Uni/bidirectional	Uni/bidirectional	Uni/bidirectional
Communication	Optional HART®	Add-on modules HART®	
Display	3 lines 20 characters (optional without display)	3 lines 20 characters (optional without display)	2 lines 16 characters
Meter uncertainty	±0,5% o.r.	±0,25% o.r.	±0,25% o.r.
Enclosure	IP 67, IP 20	IP 67, IP 20	IP 65, IP 67
Custody transfer approval		PTB OIML R75 OIML R117	
Ex-version Safety barrier		[EEx ia/ib] IIB [EEx ia] IIC	EEx de [ia/ib] IIB T6
Power supply	12-24 V a.c./d.c. 115-230 V a.c.	12-24 V a.c./d.c. 115-230 V a.c.	24 V a.c./d.c.

1. Product introduction	1.1	Product introduction	4	
	1.2	Mode of operation	5	
2. Technical data	2.1	Sensor MAG 1100 and MAG 1100 Ex	6	Technical data
	2.2	Sensor MAG 1100 FOOD	7	
	2.3	Sensor MAG 3100, MAG 3100 Ex and MAG 3100 W	8-9	
	2.4.1	Signal converter MAG 5000 (DN 6 to DN 1200)	10	
	2.4.2	Signal converter MAG 6000	11	
	2.4.3	Safety barrier (ia/ib)	12	
	2.4.4	Safety barrier (ia)	12	
	2.4.5	Cleaning unit	13	
	2.5.	Meter uncertainty	14	
	2.6	Output characteristics MAG 5000 and MAG 6000	15	
	2.7.1	Sensor cables and conductivity of medium	16	
	2.7.2	Sensor cable specification	16	
	2.7.3	Input characteristics MAG 5000 and MAG 6000	16	
	2.8	HART® communication. Add-on module	17	
	2.9	Cable data	17	
3. Project guidance	3.1	Sizing table (DN 3-2000)	18	Project guidance
	3.2.1	Minimum conductivity	19	
	3.2.2	Liner selection guide	19	
	3.2.3	Electrode selection guide	19	
	3.3	Installation conditions	20-22	
	3.4	Cleaning unit	23	
	3.5	Custody transfer approval	24	
	3.6	Ex installations	24-25	
4. Dimensions and weight	4.1	Sensor MAG 1100	26	D & W
	4.2	Sensor MAG 1100 FOOD	27-29	
	4.3	Sensor MAG 3100 and MAG 3100 W	30-31	
	4.4	Signal converter	32-34	
5. Installation of sensor	5.1	Potential equalization	35-36	Sensor
	5.2	Inlet protection MAG 3100	36	
	5.3	Cathodic protected piping	36	
6. Installation of signal converter	6.1.1	Compact installation, MAG 5000 and MAG 6000	37-38	Installation of signal conv.
	6.2.1	Add-on modules, MAG 6000 only	39	
	6.2.2	Remote installation	41-42	
	6.2.3	Remote installation, signal converter in 19" insert	43	
	6.2.4	Add-on modules, MAG 6000 only	44	
	6.2.5	Installation in IP 65 wall mounting enclosure	45	
	6.2.6	Installation in IP 65 panel mounting enclosure (front of panel)	46	
	6.2.7	Installation in the back of a panel	47	
	6.3	Signal converter, safety barrier	48	
	6.4	Signal converter, cleaning unit	49	
	6.5	Signal converter, MAG 6000 CT, sealing	50	
7. Electrical connection	7.1	Signal converter MAG 5000 and MAG 6000	51	Elec.con.
	7.2	Signal converter with safety barrier	52	
	7.3	Signal converter with cleaning unit	53	
	7.4	HART® communication	54	
8. Commissioning	8.1	Keypad and display layout	55	Commissioning
	8.2	Menu build-up	56	
	8.2.1	Password	56	
	8.3.1	MAG 5000 and MAG 6000 menu overview	57	
	8.3.2	MAG 6000 CT menu overview	58	
	8.4.1	Basic settings	59	
	8.4.2.1	Outputs	59	
	8.4.2.2	Digital and relay output	60	
	8.4.3	External input	61	
	8.4.4	Sensor characteristics	62	
	8.4.5	Reset mode	62	
	8.4.6	Service mode	63	
	8.4.7	Operator menu setup	64	
	8.4.8	Product identity	65	
	8.4.9	Change password	65	
	8.4.10	Language mode	66	
	8.4.11	HART® communication. (Add-on module)	66	
	8.5.1	Flowrate	67	
	8.5.2	Totalizer	67	
	8.5.3	Batch	67	
	8.6.1	Settings available	68	
	8.6.2	Dimension-dependent factory settings, MAG 5000 and MAG 6000	69	
	8.7.1	Error handling	70	
	8.7.2	List of error numbers	71	
9. Service	9.1	Trouble shooting, MAG 5000 and MAG 6000	72	
10. Ordering	10.1	Sensor MAG 1100	73-74	Ordering
	10.2	Adaptor MAG 1100 FOOD	75-76	
	10.3	Sensor MAG 3100 and MAG 3100 Ex	77-78	
	10.4	Sensor MAG 3100 W	79	
	10.5	Signal converter	80	
	10.6	Signal converter 19"	81	
	10.7	Accessories	82	
	10.8	Calibration	83	

1.1 Product introduction

MAGFLO® electromagnetic flowmeters offer reliable, precise and inexpensive flow measurement on all electrically conductive liquids. Typical applications are found in all industries. E.g.:

- Water sector: Potable water, treatment of chemicals, waste water and sludge.
- Food sector: Dairy products, beer, wine, soft-drinks and fruit juices.
- Chemical sector: Detergents, pharmaceuticals, acids and alkalies.
- Other sectors: District heating, paper pulp and mining slurries.

MAGFLO® electromagnetic flowmeters are characterised by simplicity:

- ⇒ Simple to install
- ⇒ Simple to commission
- ⇒ Simple to operate
- ⇒ Simple to maintain

MAGFLO® electromagnetic flowmeters are manufactured by Danfoss Instrumentation - one of the worlds leading makers of flowmeters.



All MAGFLO® electromagnetic flowmeters feature a unique SENSORPROM® memory unit which stores sensor calibration data and signal converter settings for the lifetime of the product. At commissioning the flowmeter commences measurement without any initial programming. The factory settings matching the sensor are stored in the SENSORPROM® unit. Also customer specified settings are downloaded to the SENSORPROM® unit. Should the signal converter be replaced, the new converter will upload all previous settings and resume measurement without any need for reprogramming.

1.2 Mode of operation

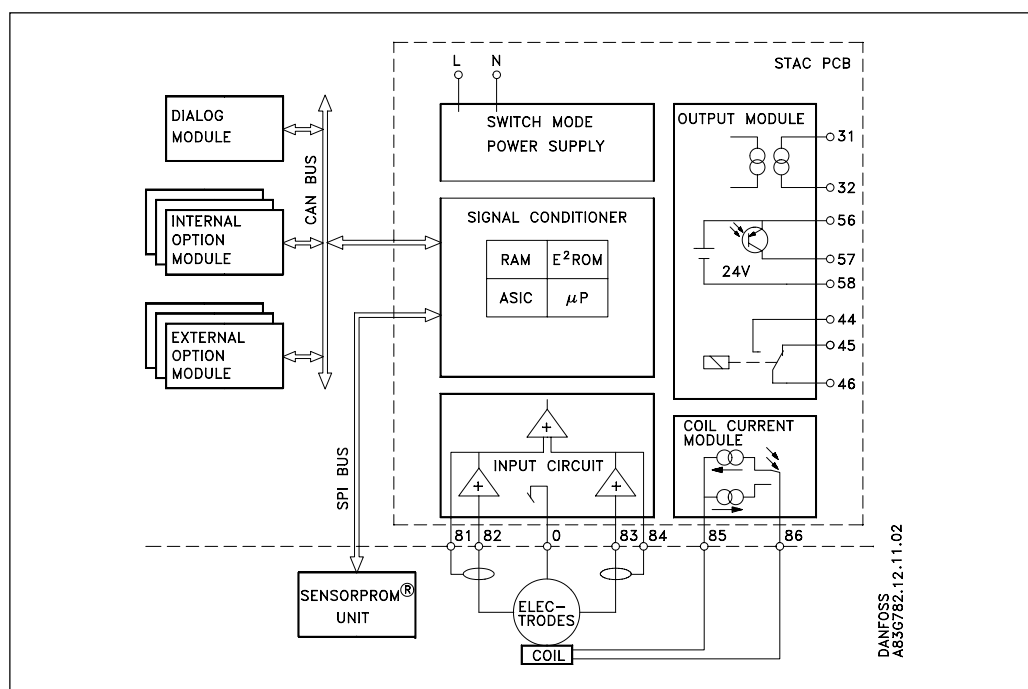

The flow measuring principle is based on Faraday's law of electromagnetic induction. The flowmeter consists of a sensor type MAG 1100 or 3100 and a signal converter type 5000 or 6000.

SENSOR

The sensor converts the flow into an electrical voltage proportional to the velocity of the flow. The sensor is built up of a stainless steel pipe, 2 coils, electrodes, an isolating liner, housing and connecting flanges.

SIGNAL CONVERTER

The signal converter consists of a number of function blocks which convert the sensor voltage into flow readings.

Power supply. 2 different types of power supply are available. A 12 - 24 V a.c./d.c. and a 115 - 230 V a.c. switch mode type.

Coil current module generates a pulsating magnetising current that drives the coils in the sensor. The current is permanently monitored and corrected. Errors or cable faults are registered by the self-monitoring circuit.

Input circuit amplifies the flow proportional signal from the electrodes. The input impedance is extremely high: $>10^{14}\Omega$, which allows flow measurements on fluids with conductivities as low as $1\mu\text{S/cm}$. Measuring errors due to cable capacitance are eliminated due to active cable screening.



Digital signal processor converts the analog flow signal to a digital signal and suppresses electrode noise through a digital filter. Inaccuracies in the signal converter as a result of long-term drift and temperature drift are monitored and continuously compensated for via the self-monitoring circuit. The analog to digital conversion takes place in an ultra low noise ASIC with 23 bit signal resolution. This has eliminated the need for range switching. The dynamic range of the signal converter is therefore unsurpassed with a turn down ratio of min. 3000:1.

CAN communication. The signal converter operates internal via an internal CAN communication bus. Signals are transferred to/from a signal conditioner to the display module, internal/external option modules and the dialog module.



Dialog module. The display unit consists of a 3-line display and a 6-key keypad. The display will show a flowrate or a totalizer value as a primary reading.

Output module converts flow data to an analog, a digital and a relay output. The outputs are galvanically isolated and can be individually set to suit a particular application.

2.1 Sensor MAG 1100 and MAG 1100 Ex

	MAG 1100 	MAG 1100 Ex & Ex-d 
Type	Flangeless sensor (Sandwich design)	Flangeless sensor (Sandwich design)
Nominal size	DN 6, 10, 15, 25, 40, 65, 80, 100 mm	DN 6, 10, 15, 25, 40, 65, 80, 100 mm
Operating pressure	PN 40. Vacuum: 1×10^{-6} bar	PN 40. Vacuum: 1×10^{-6} bar
Temperature of medium		
<i>Ceramic</i>	-20°C to +150°C	-20°C to +120°C
<i>High temp.</i>	-20°C to +200°C	
Temperature shock (Ceramic liner)	(Duration > 1 min.):	(Duration > 1 min.):
	DN 6, 10, 15, 25 Max. $\Delta T \leq 15^\circ\text{C}/\text{min.}$	DN 6, 10, 15, 25 Max. $\Delta T \leq 15^\circ\text{C}/\text{min.}$
	DN 40, 50, 65 Max. $\Delta T \leq 10^\circ\text{C}/\text{min.}$	DN 40, 50, 65 Max. $\Delta T \leq 10^\circ\text{C}/\text{min.}$
	DN 80, 100 Max. $\Delta T \leq 5^\circ\text{C}/\text{min.}$	DN 80, 100 Max. $\Delta T \leq 5^\circ\text{C}/\text{min.}$
	(Duration ≤ 1 min., followed by 10 min. rest):	(Duration ≤ 1 min., followed by 10 min. rest):
	DN 6, 10, 15, 25 Max. $\Delta T \leq 80^\circ\text{C}$	DN 6, 10, 15, 25 Max. $\Delta T \leq 80^\circ\text{C}$
	DN 40, 50, 65 Max. $\Delta T \leq 70^\circ\text{C}$	DN 40, 50, 65 Max. $\Delta T \leq 70^\circ\text{C}$
	DN 80, 100 Max. $\Delta T \leq 60^\circ\text{C}$	DN 80, 100 Max. $\Delta T \leq 60^\circ\text{C}$
Ambient temperature	Remote signal converter: -40°C to +100°C	Remote signal converter: -40°C to +100°C
	Compact signal converter: -20°C to +50°C	Compact signal converter: -20°C to +50°C
Liner	Aluminium oxide Al_2O_3 (ceramics)	Aluminium oxide Al_2O_3 (ceramics)
Electrodes	Platinum with gold/titanium brazing alloy	Platinum with gold/titanium brazing alloy
Enclosure	Stainless steel AISI 316 (1.4436)	Stainless steel AISI 316 (1.4436)
Terminal box <i>Standard</i>	Fibre glass-reinforced polyamide	Stainless steel AISI 316 (1.4436)
<i>High temp.</i>	Stainless steel AISI 316 (1.4436)	
Fixing studs	Stainless steel AISI 304 (1.4301)	Stainless steel AISI 304 (1.4301)
	Number and size to DIN 2501	Number and size to DIN 2501
Mating flanges	DIN 2501 (PN 10-40), ANSI B16.5 class 150 and 300 or equivalent	To DIN 2501 (PN 10-40), ANSI B16.5 class 150 and 300 or equivalent
<i>Option</i>	DN 6/10: ½" pipe connection adapters thread: ½" tapered ISO 7-1	
Gaskets <i>Standard</i>	EPDM (max. 150°C, PN 40)	EPDM (max. 150°C, PN 40)
<i>Option</i>	Graphite (max. 200°C, PN 40)	Graphite (max. 200°C, PN 40)
<i>Option</i>	PTFE (max. 130°C, PN 25)	PTFE (max. 130°C, PN 25)
Cable entries	4 pcs. Pg 13.5	4 pcs. Pg 13.5
Enclosure rating		
<i>Standard</i>	IP 67 to IEC 529 (3 m w.g. for 72 h)	IP 67 to IEC 529 (1 m w.g. for 30 min.)
<i>Option</i>	IP 68 (10 m w.g. with submersible kit)	
Mechanical load (vibration)	18-1000 Hz random, 3.17 G rms, in all directions, to IEC 68-2-36	18-1000 Hz random in all directions, to IEC 68-2-36 Sensor: 3.17 G Compact Ex-d.: 1.14 G
Test pressure	80 bar (2 × PN)	80 bar (2 × PN)
Ex approvals		EEx [ia/ib] IIB T4-T6/DEMKO, No. 97D.121909X EEx de [ia/ib] IIB T4-T6/DEMKO 94C.115327X
Excitation frequency	DN 6-65: 12.5 Hz DN 80-100: 6.25 Hz	DN 6-65: 12.5 Hz DN 80-100: 6.25 Hz



2.2 Sensor MAG 1100 FOOD

	MAG 1100 FOOD	MAG 1100 FOOD PFA
		
Type	Hygienic sensor	
Nominal size	DN 10, 15, 25, 40, 50, 65, 80, 100 mm	
Process connection	Hygienic adapters available for: ◆ Direct welding into dairy pipe ◆ Clamp fitting ◆ Threaded fitting	
Operating pressure	40 bar	20 bar
<i>Vacuum</i>	1 × 10 ⁻⁶ bar	0.02 bar
Temperature of medium	-20°C to +150°C	-30°C to +130°C
	Suitable for steam sterilization	Suitable for steam sterilization at 150°C
Temperature shock	(Duration > 1 min.): DN 6, 10, 15, 25 Max. ΔT ≤ 15°C/min. DN 40, 50, 65 Max. ΔT ≤ 10°C/min. DN 80, 100 Max. ΔT ≤ 5°C/min. (Duration ≤ 1 min., followed by 10 min. rest): DN 6, 10, 15, 25 Max. ΔT ≤ 80°C DN 40, 50, 65 Max. ΔT ≤ 70°C DN 80, 100 Max. ΔT ≤ 60°C	Max. ±100°C momentarily
Ambient temperature	Remote signal converter: -40°C to +100°C Compact signal converter: -20°C to +50°C	Remote signal converter: -40°C to +100°C Compact signal converter: -20°C to +50°C
Liner	Aluminium oxide Al ₂ O ₃ (ceramic)	Reinforced PFA (Teflon)
Electrodes	Platinum/gold/titanium	Hastelloy C-276
Enclosure	Stainless steel AISI 316 (1.4436)	Stainless steel AISI 316 (1.4436)
Terminal box	<i>Standard</i> Fibre glass-reinforced polyamide <i>Option</i> Stainless steel AISI 316 (1.4436)	Fibre glass-reinforced polyamide Stainless steel AISI 316 (1.4436)
Cable entries	4 pcs. Pg 13.5	4 pcs. Pg 13.5
Enclosure rating	<i>Standard</i> IP 67 to IEC 529 (3 m w.g. for 72 h) <i>Option</i> IP 68 to 10 m w.g. with submersible kit	IP 67 to IEC 529 (3 m w.g. for 72 h) IP 68 to 10 m w.g. with submersible kit
Mechanical load (vibration)	18-1000 Hz random, 3.17 G rms, in all directions, to IEC 68-2-36	18-1000 Hz random, 3.17 G rms, in all directions, to IEC 68-2-36
Test pressure	80 bar (2 × PN)	40 bar (2 × PN)
Approvals	3A, EHEDG	3A
Excitation frequency	DN 10-65: 12.5 Hz DN 80-100: 6.25 Hz	DN 10-65: 12.5 Hz DN 80-100: 6.25 Hz

Accessories
MAG 1100 FOOD

Adapter	Stainless steel AISI 316	
Pipe connection/ Operating pressure	Adapter for direct welding into dairy pipe: ISO 2037, DIN 11850, SMS 3008, BS 4825-1 DN 10, 15, 25, 40, 50, 65, 80 DN 100	PN 40 PN 25
	Clamp adapter: ISO 2852, DIN 32676, SMS 3016, BS 4825-3 DN 10, 15, 25, 40, 50 DN 65, 80, 100	PN 16 PN 10
	Thread adapter: DIN 11851: DN 10, 15, 25, 40 DN 50, 65, 80, 100 ISO 2853, SS 3351, BS 4825-4: DN 10, 15, 25, 40, 50, 65, 80 SMS 1145: DN 25, 40, 50, 65, 80	PN 40 PN 25 PN 16 PN 6
Gasket	<i>Standard</i> EPDM (-20 °C to 150 °C)	
	<i>Option</i> NBR (-20 °C to 100 °C)	
Clamp	Stainless steel AISI 304, ISO 2852	

2.3 Sensor MAG 3100, MAG 3100 Ex and MAG 3100 W

	MAG 3100 	MAG 3100 Ex / Ex-d 	MAG 3100 W 
Type	Sensor with flanges	Sensor with flanges	Sensor with flanges
Nominal size	DN 15-2000 mm	DN 15-2000 mm / 15-300 mm	DN 25-1200 mm
Temperature of medium	Temperature classification		
Liner:		T3 + T4	T5
Neoprene (standard)	0 to 95°C	0 to 95°C	0 to 90°C
EPDM ¹⁾	-10 to 95°C	-10 to 95°C	-10 to 90°C
Linatex® rubber	-40 to 70°C	-20 to 70°C	-20 to 70°C
Ebonite ¹⁾	0 to 95°C	0 to 95°C	0 to 90°C
Polyurethane	0 to 50°C	0 to 50°C	0 to 50°C
PTFE	-20 to 120°C	-20 to 120°C	-20 to 90°C
PTFE high temperature	-20 to 180°C		
Ambient temperature			
Remote signal converter	-40°C to 100°C	-20°C to 40 (50)°C ²⁾	-40°C to 100°C
Compact signal converter	-20°C to 50°C	-20°C to 40 (50)°C ²⁾	-20°C to 50°C
Operating pressure³⁾ [abs.bar]			
Liner:			
Neoprene	0.01 to 100 bar	0.01 to 100 bar	0.01 to 40 bar
EPDM	0.01 to 40 bar	0.01 to 40 bar	0.01 to 40 bar
Natural rubber & Linatex®	0.01 to 40 bar	0.01 to 40 bar	
Ebonite	0.01 to 100 bar	0.01 to 100 bar	
Polyurethane	0.4 to 100 bar	0.4 to 100 bar	
PTFE teflon:			
DN 15 to 600	Max. 100°C: 0.3 to 40 bar	0.3 to 40 bar	
DN 15 to 600	Max. 120°C: 0.5 to 40 bar		
DN 15 to 300	Max. 180°C: 0.6 to 40 bar		
Excitation frequency	DN ≤ 65: 12 1/2 Hz DN 65 < DN ≤ 300: 6 1/4 Hz DN 300 < DN ≤ 1200: 3 1/8 Hz DN > 1200: 1 9/16 Hz	DN ≤ 65: 12 1/2 Hz DN 80/100: 6 1/4 Hz DN ≥ 125: 3 1/8 Hz	All sizes: 3 1/8 Hz
Enclosure rating	<i>Standard</i> IP 67 to IEC 529 (3 m w.g. for 72 h) <i>Option</i> IP 68 to IEC 529 (10 m w.g.)		
Cable entries	4 pcs. Pg 13.5 - 2 others available		
Mechanical load	18-1000 Hz random, 3.17 G rms, in all directions, to IEC 68-2-36		
Design pressure	1.5 × PN		

1) With WRC (Water Research Council, UK) approval

2) 50°C for DN 125-300 only



3) Maximum operating pressure decreases with increasing operating temperature and with stainless steel flanges

Standard flanges above 120°C: BS 4504 sec. 3.1 table 15 material group A1

AISI 304 flanges: BS 4504 sec. 3.1 table 16 material group B2

AISI 316 flanges: BS 4504 sec. 3.1 table 16 material group B4

2.3 Sensor MAG 3100, MAG 3100 Ex and MAG 3100 W (continued)

	MAG 3100	MAG 3100 Ex / Ex-d	MAG 3100 W
			
Flanges			
<i>Standard</i>	DN 15-50: PN 40 DN 65-150: PN 16 DN 200-1000: PN 10 DN 1100-1200: PN 6 DN 1400-2000: PN 6		DN 25-50: PN 40 DN 65-150: PN 16 DN 200-1200: PN 10
<i>Option</i>	DN 65-1000: PN 6 DN 1200-2000: PN 10 DN 200-2000: PN 16 DN 200-600: PN 25 DN 65-600: PN 40 DN 50-400: PN 64 (DIN 2636) DN 25-350: PN 100 (DIN 2637)		DN 200-600: PN 16
ANSI B 16.5 (~BS 1560)	3/4"-24": Class 150 (20 bar) 3/4"-24": Class 300 (50 bar)		3/4"-24": Class 150 (20 bar)
BS 10	3/4"-60": Table D/E		
AS 2129	3/4"-48": Table D/E		
AS 4087	DN 50-1200 (14 bar)		
JIS B 2220	DN 50-1000: K10 (10 bar) DN 50-1200: K16 (16 bar)		
AWWA C-207	28"-78": Class D (10 bar)		28"-48": Class D (10 bar)
Electrodes			
<i>Standard</i>	AISI 316 Ti (1.4571)		AISI 316 Ti (1.4571)
<i>Option</i>	Hastelloy C-276, Platinum / Iridium, Titanium, Monel (Alloy 400), AISI 316 Ti Ceramic Coated, Tantalum		
Earthing electrodes			
<i>Standard</i>	Not included		AISI 316 Ti (1.4571)
<i>Option</i>	AISI 316 Ti (1.4571), Hastelloy C276 All liner materials except PTFE		
Measuring pipe	AISI 304 (1.4301)		
Flange and housing material			
<i>Standard</i>	Low grade carbon steel BS 4360 grade 43A (St. 37.2) Corrosion-resistant two-component coating (min. 150 µm)		Low grade carbon steel BS 4360 grade 43A (St. 37.2) Corrosion-resistant two-component coating (min. 150 µm)
<i>Option</i>	AISI 304 (1.4301) flanges and St. 37.2 housing. Coating as above		
<i>Option</i>	AISI 316 (1.4436/1.4401) flanges and housing		
Ex-approval			
<i>Remote</i>	DN 15-100 EEx [ia/ib] m IIB T4-T6 DN 125-300 EEx [ia/ib] e IIB T4-T6 DN 350-2000 EEx e [ia] IIC T3-T6		
<i>Compact</i>	DN 15-300 EEx de [ia/ib] IIB T4-T6 MAG 3000 Ex-d		

2.4.1 Signal converter MAG 5000 (DN 6 to DN 1200)

	Accuracy 0.5%
Current output	
Current	0-20 mA or 4-20 mA
Load	< 800 ohm
Time constant	0.1-30 s adjustable
Digital output	
Frequency	0-10 kHz, 50% duty cycle
Time constant	0.1-30 s adjustable
Active	24 V d.c., 30 mA, $1\text{ K}\Omega \leq R_{load} \leq 10\text{ K}\Omega$, short-circuit-protected
Passive	3-30 V d.c., max. 110 mA, $200\ \Omega \leq R_{load} \leq 10\text{ K}\Omega$
Relay	Changeover relay
Load	42 V a.c./2 A, 24 V d.c./1A
Digital input	11-30 V d.c., $R_i = 4.4\text{ K}\Omega$
Activation time	50 ms
Current	$I_{11\text{ V d.c.}} = 2.5\text{ mA}$, $I_{30\text{ V d.c.}} = 7\text{ mA}$
Functions	Flowrate, 2 totalizers, low flow cut-off, empty pipe cut-off, flow direction, error system, operating time, uni/bidirectional flow, limit switches, pulse output, control for cleaning unit
Galvanic isolation	All inputs and outputs are galvanically isolated
Cut-off	
Low-flow	0-9.9% of maximum flow
Empty pipe	Detection of empty pipe
Totalizer	Two eight-digit counters for forward, net or reverse flow
Display	Background illumination with alphanumerical text, 3 x 20 characters to indicate flowrate, totalized values, settings and faults. Reverse flow indicated by negative sign.
Time constant	Time constant as current output time constant
Zero point adjustment	Automatic
Electrode input impedance	$> 1 \times 10^{14}\ \Omega$
Excitation frequency	$3\ \frac{1}{8}\text{ Hz}$ pulsating d.c. current (125 mA)
Ambient temperature	Display version during operation: -20 to +50°C Blind version during operation: -20 to +60°C During storage: -40 to +70°C (RH max. 95%)
Communication	
Standard	Without serial communication
Optional	HART®
Compact	
Enclosure material	Fibre glass-reinforced polyamide
Enclosure rating	IP 67 to IEC 529 and DIN 40050 (1 m w.g. for 30 min.)
Mechanical load	18-1000 Hz random, 3.17 G rms, in all directions, to IEC 68-2-36
19" insert	
Enclosure material	Standard 19" insert of aluminium/steel (DIN 41494)
Width:	21 TE
Height:	3 HE
Enclosure rating	IP 20 to IEC 529 and DIN 40050
Mechanical load	Version: 1 G, 1-800 Hz sinusoidal in all directions, to IEC 68-2-6
EMC performance	Emission: EN 50081-1 (Light industry) Immunity: EN 50082-2 (Industry)
Supply voltage	115-230 V a.c. +10% - -15%, 50-60 Hz 11-30 V d.c. or 11-24 V a.c.
Power consumption	230 V a.c.: 9 VA 24 V d.c.: 6 W, $I_N = 250\text{ mA}$, $I_{ST} = 8\text{ A}$ (30 ms) 12 V d.c.: 5 W, $I_N = 400\text{ mA}$, $I_{ST} = 4\text{ A}$ (250 ms)

2.4.2 Signal converter MAG 6000

	Accuracy 0.25%	
Current output		
Current	0-20 mA or 4-20 mA	
Load	< 800 ohm	
Time constant	0.1-30 s adjustable	
Digital output		
Frequency	0-10 kHz, 50% duty cycle	
Time constant	0.1-30 s adjustable	
Active	24 V d.c., 30 mA, $1\text{ K}\Omega \leq R_{\text{load}} \leq 10\text{ K}\Omega$, short-circuit-protected	
Passive	3-30 V d.c., max. 110 mA, $200\ \Omega \leq R_{\text{load}} \leq 10\text{ K}\Omega$	
Relay	Changeover relay	
Load	42 V a.c./2 A, 24 V d.c./1A	
Digital input	11-30 V d.c., $R_i = 4.4\text{ K}\Omega$	
Activation time	50 ms	
Current	$I_{11\text{ V d.c.}} = 2.5\text{ mA}$, $I_{30\text{ V d.c.}} = 7\text{ mA}$	
Functions	Flowrate, 2 totalizers, low flow cut-off, empty pipe cut-off, flow direction, error system, operating time, uni/bidirectional flow, limit switches, pulse output, control for cleaning unit and batch	
Galvanic isolation	All inputs and outputs are galvanically isolated	
Cut-off		
Low-flow	0-9.9% of maximum flow	
Empty pipe	Detection of empty pipe	
Totalizer	Two eight-digit counters for forward, net or reverse flow	
Display	Background illumination with alphanumeric text, 3 x 20 characters to indicate flowrate, totalized values, settings and faults. Reverse flow indicated by negative sign.	
Time constant	Time constant as current output time constant	
Zero point adjustment	Automatic	
Electrode input impedance	$> 1 \times 10^{14}\ \Omega$	
Excitation frequency	Pulsating d.c. current (125 mA) with one of the following frequencies: 1 $\frac{9}{16}$ Hz, 3 $\frac{1}{8}$ Hz, 6 $\frac{1}{4}$ Hz, 12 $\frac{1}{2}$ Hz or 25 Hz	
Ambient temperature	Display version during operation: -20 to +50°C Blind version during operation: -20 to +60°C During storage: -40 to +70°C (RH max. 95%)	
Custody transfer approval	PTB DANAK OIML R75 DANAK OIML R117	
MAG 6000 CT only	(cold water)	(hot water) (cold water/milk, beer etc.)
Communication		
Standard	Prepared for client mounted add-on modules	
Optional	HART® as add-on module	
Compact		
Enclosure material	Fibre glass-reinforced polyamide	
Enclosure rating	IP 67 to IEC 529 and DIN 40050 (1 m w.g. for 30 min.)	
Mechanical load	18-1000 Hz random, 3.17 G rms, in all directions, to IEC 68-2-36	
19" insert		
Enclosure material	Standard 19" insert of aluminium/steel (DIN 41494)	
	Width: 21 TE	
	Height: 3 HE	
Enclosure rating	IP 20 to IEC 529 and DIN 40050	
Mechanical load	Version: 1 G, 1-800 Hz sinusoidal in all directions, to IEC 68-2-6	
EMC performance	Emission: EN 50081-1 (Light industry) Immunity: EN 50082-2 (Industry)	
Supply voltage	115-230 V a.c. +10% - -15%, 50-60 Hz, 9 VA 11-30 V d.c. or 11-24 V a.c., 9 W	
Power consumption	230 V a.c.: 9 VA 24 V d.c.: 6 W, $I_N = 250\text{ mA}$, $I_{ST} = 8\text{ A}$ (30 ms) 12 V d.c.: 5 W, $I_N = 400\text{ mA}$, $I_{ST} = 4\text{ A}$ (250 ms)	

2.4.3 Safety barrier (ia/ib)

		DN ≤ 300	
Application		For use with MAG 5000/6000 19" insert and MAG 1100 Ex/3100 Ex in the size range DN 6-300	
Ex approval		[EEx ia/ib] IIB	
Cable parameter		Group	
		Capacity in μF	
Electrode cable		IIB	≤ 31
Coil cable		IIB	≤ 0.5
Ambient temperature		During operation: -20 to $+50^{\circ}\text{C}$	
		During storage: -20 to $+70^{\circ}\text{C}$	
19" insert		Enclosure material	
		Standard 19" insert in aluminium/steel (DIN 41494)	
		Width: 21 TE	
		Height: 3 HE	
Enclosure rating		IP 20 to IEC 529 and DIN 40050	
Mechanical load		1 G, 1-800 Hz sinusoidal in all directions, to IEC 68-2-6	
EMC performance		Emission	
		EN 50081-1 (Light industry)	
		Immunity	
		EN 50082-2 (Industry)	

2.4.4 Safety barrier (ia)

		DN ≥ 350		
Application		For use with MAG 5000/6000 19" insert and MAG 3100 Ex in the size range DN 350-2000		
Ex approval		[EEx ia] IIC		
Cable parameter		Group		
		Capacity in μF		
		Inductance in μH		
		IIC	≤ 4.1	≤ 1.5
		IIB	≤ 45	≤ 87
		IIA	≤ 45	≤ 87
Ambient temperature		During operation: -20 to $+50^{\circ}\text{C}$		
		During storage: -20 to $+70^{\circ}\text{C}$		
19" insert		Enclosure material		
		Standard 19" insert in aluminium/steel (DIN 41494)		
		Width: 21 TE		
		Height: 3 HE		
Enclosure rating		IP 20 to IEC 529 and DIN 40050		
Mechanical load		1 G, 1-800 Hz sinusoidal in all directions, to IEC 68-2-6		
EMC performance		Emission		
		EN 50081-1 (Light industry)		
		Immunity		
		EN 50082-2 (Industry)		

2.4.5 Cleaning unit

	
Application	For use together with MAG 5000 and 6000 19" insert to clean the electrodes on MAG 1100 or MAG 3100. NB Must not be used with intrinsically safe systems
Cleaning voltage (unloaded) a.c. cleaning d.c. cleaning	60 V a.c. 30 V d.c.
Cleaning period	60 sec. + 60 sec. pause period
Relay Load	Switch relay activated when cleaning is in progress 42 V/2 A
Operation Automatic Manual	Yes No
Indicator lamps	LEDs: "ON" and "CLEANING"
Supply voltage and power consumption	115-230 V a.c. +10% to -15%, 50-60 Hz, 7 VA cleaning, 5 VA stand by
Ambient temperature	During operation: -20 to +50°C During storage: -20 to +70°C
19" insert Enclosure material Enclosure rating Mechanical load	Standard 19" insert in aluminium/steel (DIN 41494) Width: 21 TE Height: 3 HE IP 20 to IEC 529 and DIN 40050 1 G, 1-800 Hz sinusoidal in all directions, to IEC 68-2-6

2.5 Meter uncertainty

MAG 5000

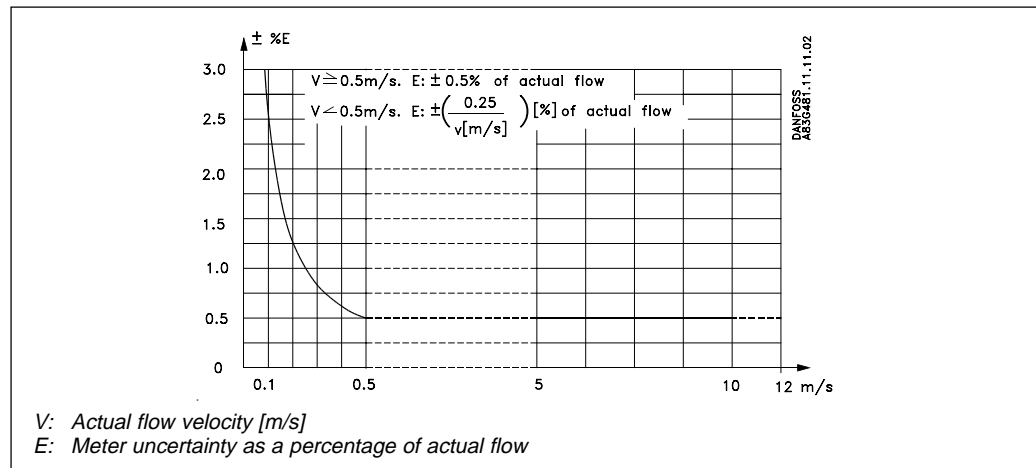

MAG 6000

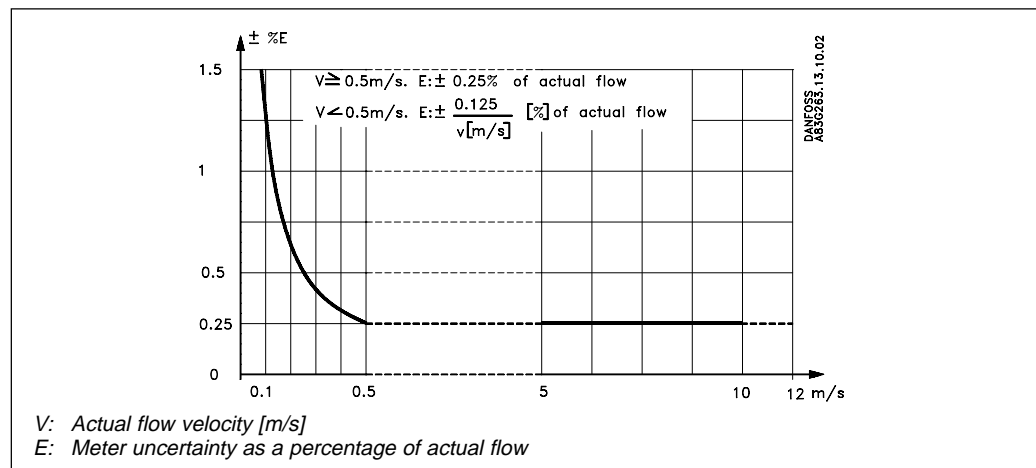

Reference conditions (ISO 9104 and DIN/EN 29104)

Temperature of medium	20°C ±2 K
Ambient temperature	20°C ±2 K
Supply voltage	Un ±1%
Warming-up time	30 min.
Incorporation in pipe section	Inlet section 10×DN (DN ≤ 1200), 5×DN (DN > 1200) Outlet section 5×DN (DN ≤ 1200), 3×DN (DN > 1200)
Flow conditions	Fully developed flow profile

Additions in the event of deviations from reference conditions

Current output	As pulse output ±(0.1% of actual flow +0.05% FSO)
Effect of ambient temperature	Display/frequency/pulse output: < ±0.003% / K act.
	Current output: < ±0.005% / K act.
Effect of supply voltage	< 0.005% of measuring value on 1% change
Repeatability	±0.1% of actual flow for V ≥ 0.5 m/s

For the sizes DN 1400 to DN 2000 the measuring accuracy is +/- 0.5% as standard and MAG 6000 only must be used. (+/- 0.25% as option).

For all MAG 3100 W sizes the measuring accuracy is +/- 0.5%.

2.6
Output characteristics
MAG 5000 and MAG 6000

Output characteristics 0-20 mA	Bidirectional mode		Unidirectional mode	
4-20 mA				
Frequency				
Totalizer forward				
Reverse				
Net flow				
Relay	Power down	Active	Power down	Active
Error relay	No error	Error	No error	Error
Limit switch	1 set point		2 set points	
	Low flow	Intermediate flow	High flow	High flow/ Low flow
	High flow			
Batch on digital output				

Technical data

2.7.1
Sensor cables and conductivity of medium

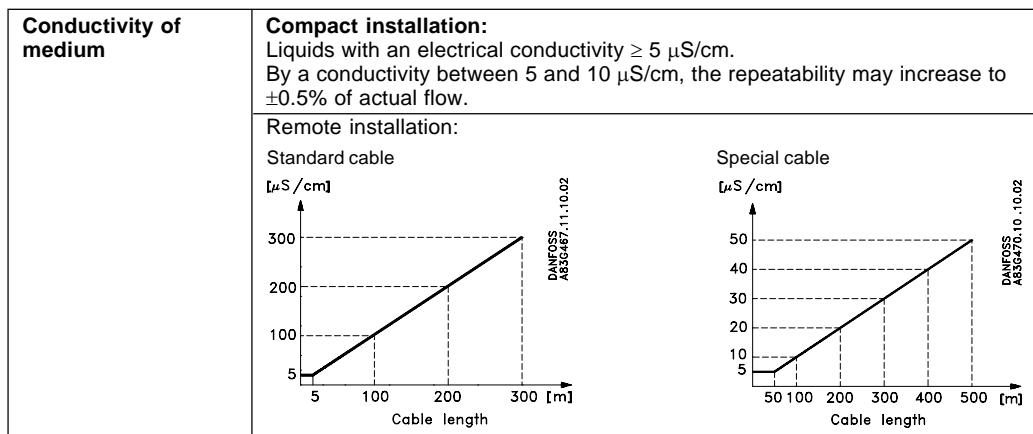

NB

By detection of empty sensor the min. conditivity must always be $\geq 20 \mu\text{S/cm}$ and the max. length of electrode cable when remote mounted is 50 metres. Special cable must be used.
By remote mounting in Ex applications special cable cannot be used, empty sensor cannot be detected and the electrical conductivity must be $\geq 30 \mu\text{S/cm}$.

2.7.2
Min. sensor cable data

		<i>Coil cable</i>	<i>Electrode cable</i>
Basic data	No. of conductors	2	3
	Min. sqr. area	0.5 mm^2	0.2 mm^2
	Max. capacitance	N.A.	350 pF/m
Max. cable loop resistance	Media temperature: $< 100^\circ\text{C}$	40Ω	N.A.
	$< 200^\circ\text{C}$	6Ω	N.A.

2.7.3
Input characteristics
MAG 5000 and MAG 6000

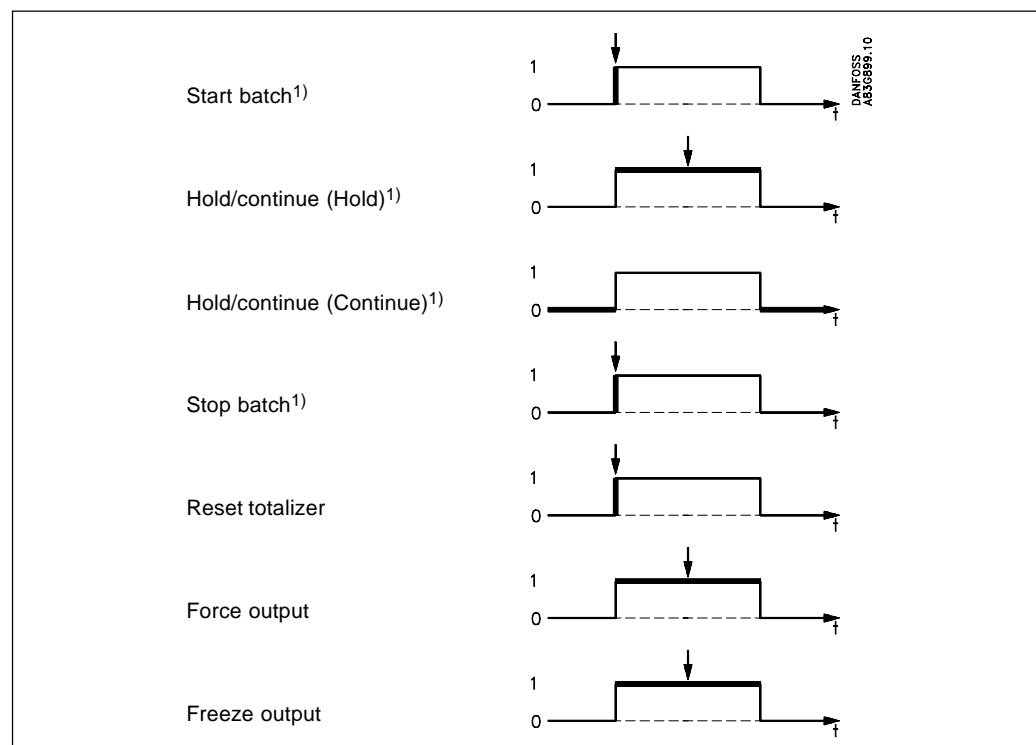

¹⁾ MAG 6000 only

2.8 HART® communication add-on module

Application	MAG 6000, MAG 6000 CT Optional available as factory mounted in MAG 5000
Communication standard	Bell 202 frequency shift keying (f.s.k.) standard
Communication modes	<ul style="list-style-type: none"> • Single loop mode • Multi-drop mode, 14 slave devices
Communicator	Rosemount Hand-held communicator type 275

Cable specification

		Communication mode
		Single loop
Q [mm ²] CU		≥ 0.2 mm ² /AWG 24
Screen		YES (Overall screen)
Loop resistance	<i>Min.</i>	230 Ω
	<i>Max.</i>	800 Ω
Cable capacity		≤ 400 pF/m
Cable length		1500 m
Twisted pair		YES

HART® is a registered trademark of the HART Communication Foundation.

2.9 Cable data (Supplied by Danfoss)

		Standard cable	Special electrode cable
Basic data	No. of conductors	3	3
	Sqr. area	1.5 mm ²	0.25 mm ²
	Screen	Yes	Double
	Color code	Brown, blue, black	Brown, blue, black
	Outside color	Grey	Grey
	Ext. diameter	7.8 mm	8.1 mm
	Conductor	Flexible CU	Flexible CU
	Isolation material	PVC	PVC
Amb. temperature	• Flexible installation	-5 to 70°C	-5 to 70°C
	• Non flexible installation	-30 to 70°C	-30 to 70°C
Cable parameter	Capacity	161.50 pF/m	N.A.
	Inductance	0.583 μH/m	N.A.
	L/R	43.83 μH/Ω	N.A.

3.1 Sizing table (DN 3-2000)

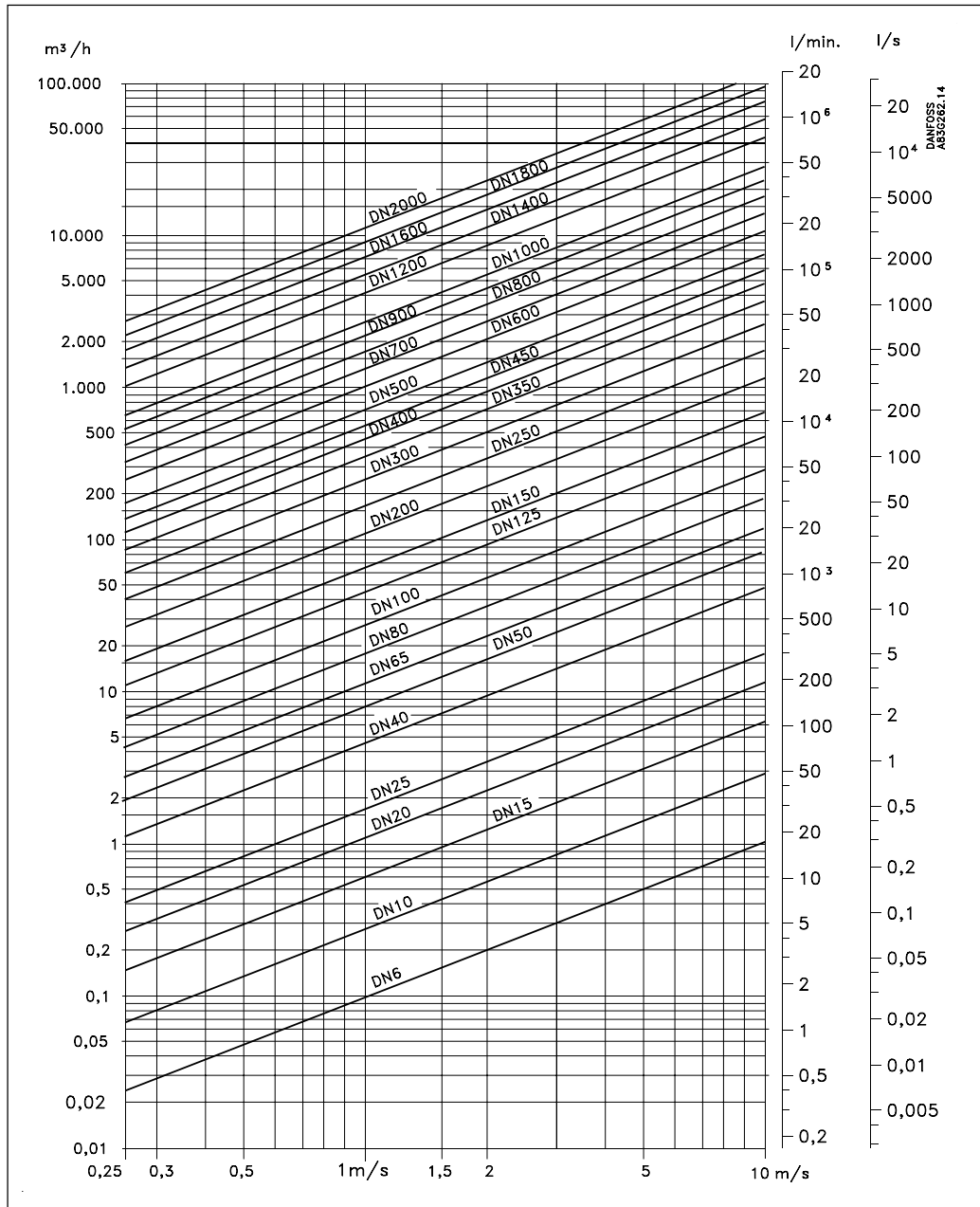

The table shows the relationship between flow velocity V , flow quantity Q and sensor dimension DN .

Guidelines for selection of sensor

Min. measuring range: 0-0.25 m/s

Max. measuring range: 0-10 m/s

Normally the sensor is selected so that V lies within the measuring range 1-2 m/s.

Flow velocity calculation formula:

$$V = \frac{1273.24 \times Q \text{ [l/s]}}{DN^2 \text{ [mm]}} \text{ [m/s]} \text{ or } V = \frac{353.68 \times Q \text{ [m}^3\text{/h]}}{DN^2 \text{ [mm]}} \text{ [m/s]}$$

**3.2.1
Minimum conductivity**

Applications	Min. conductivity
Compact mounted	5 µS/cm
Remote mounted	5 µS/cm
With empty pipe detection	20 µS/cm
Ex-installations (Remote mounted only)	30 µS/cm
District heating systems (Without DC cleaning unit)	250 µS/cm

**3.2.2
Liner selection guide**

Liner	Applications
Ceramics Al ₂ O ₃	General purpose, aggressive chemicals
PFA	General purpose, dairy, food and beverage
Neoprene	General purpose, sewage, drinking water and district heating
EPDM	Drinking water, sea water
PTFE	Aggressive chemicals, paper and pulp, high temperature applications
Polyurethane	Abrasive media, high pressure applications,
	Sewage with hydro carbons (Solvents, oils, etc.)
Linatex®	Abrasive media and mining slurries
Ebonite	Drinking water, high pressure applications and district heating

**3.2.3
Electrode selection guide**

Electrodes	Applications
AISI 316 Ti	General purpose, water, sewage and district heating
AISI 316 Ti Ceramic coated	High content of fibres, paper pulp
Hastelloy C-276	Good chemical properties, sea water
Monel	Salt, brine and alkaline solutions
Titanium	Chlorine, chlorite, nitric and chromic acids.
	Textile bleaching industry
Tantalum	Almost any acid solution
Platinum and platinum/irridium	The ultimate electrode material. Unaffected by most liquids

3.3 Installation conditions

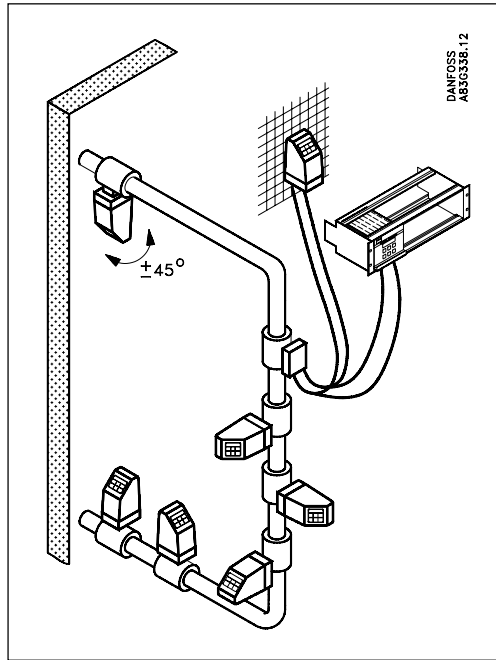

Reading and operating the flowmeter is possible under almost any installation conditions because the display can be oriented in relation to the sensor. To ensure optimum flow measurement, attention should be paid to the following:

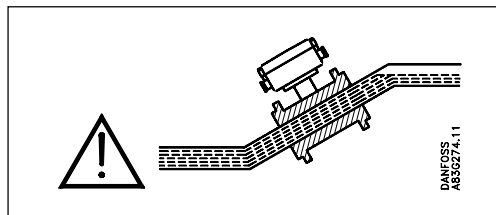

The sensor must always be completely full with liquid.

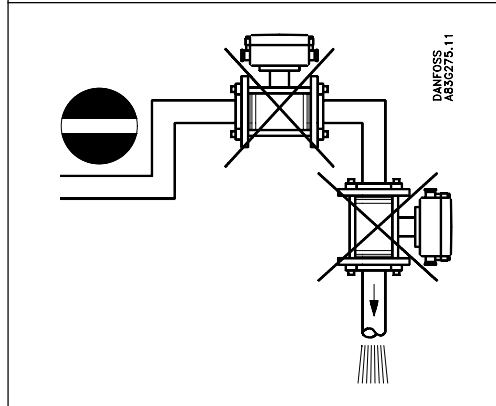

Therefore avoid:

- Installation at the highest point in the pipe system
- Installation in vertical pipes with free outlet

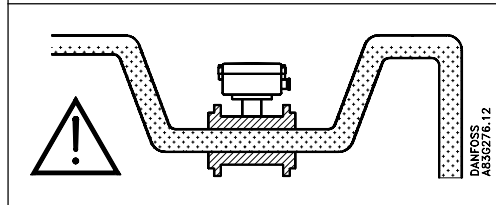

For partially filled pipes or pipes with downward flow and free outlet the flowmeter should be located in a U-tube.

Installation in vertical pipes

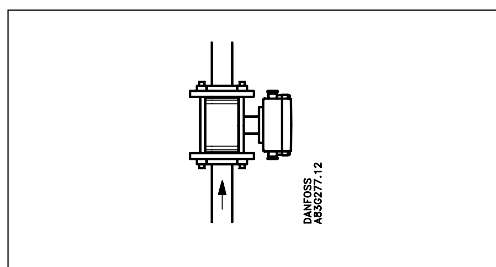

Recommended flow direction: upwards. This minimizes the effect on the measurement of any gas/air bubbles in the liquid.

Installation in horizontal pipes

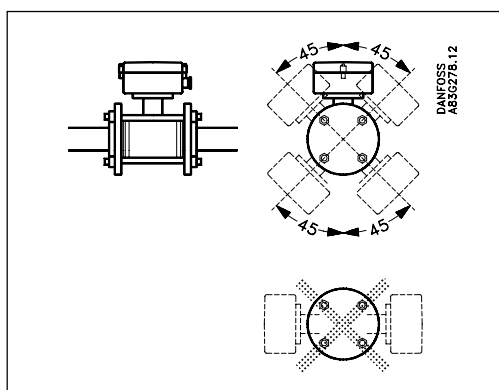

The sensor must be mounted as shown in the upper figure. Do not mount the sensor as shown in the lower figure. This will position the electrodes at the top where there is possibility for air bubbles and at the bottom where there is possibility for mud, sludge, sand etc. If using empty pipe detection, the sensor can be tilted 45°, as shown in the upper figure.

Measuring abrasive liquids and liquids containing particles

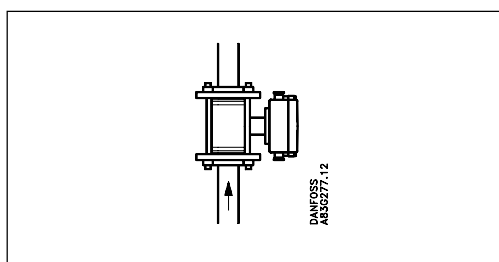

Recommended installation is in a vertical/ inclined pipe to minimize the wear and deposits in the sensor.

Inlet and outlet conditions

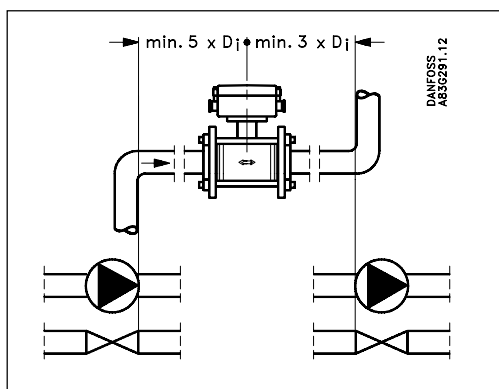

To achieve accurate flow measurement it is essential to have straight lengths of inlet and outlet pipes and a certain distance between pumps and valves. It is also important to centre the flowmeter in relation to pipe flanges and gaskets.

Potential equalization

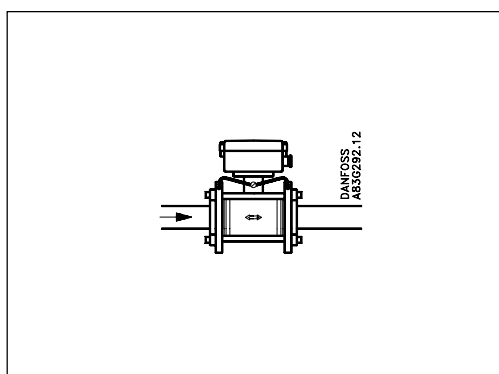

The electrical potential of the liquid **must always** be equal to the electrical potential of the sensor. This can be achieved in different ways depending on the application:

- Wire jumper between sensor and adjacent flanges. (MAG 1100 and MAG 3100).
- Direct metallic contact between sensor and fittings. (MAG 1100 FOOD).
- Built-in earthing electrodes. (MAG 3100 and MAG 3100 W).
- Optional earthing/protection flanges/rings. (MAG 1100 and MAG 3100).
- Optional graphite gaskets on MAG 1100. (Standard for MAG 1100 High temperature).

Vacuum

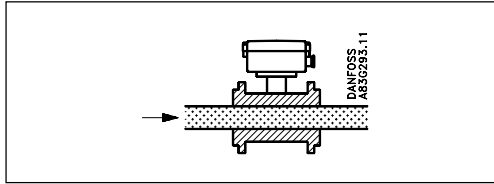

Avoid a vacuum in the measuring pipe, since this can damage certain liners. See "Technical data", section 2.

Installation in large pipes

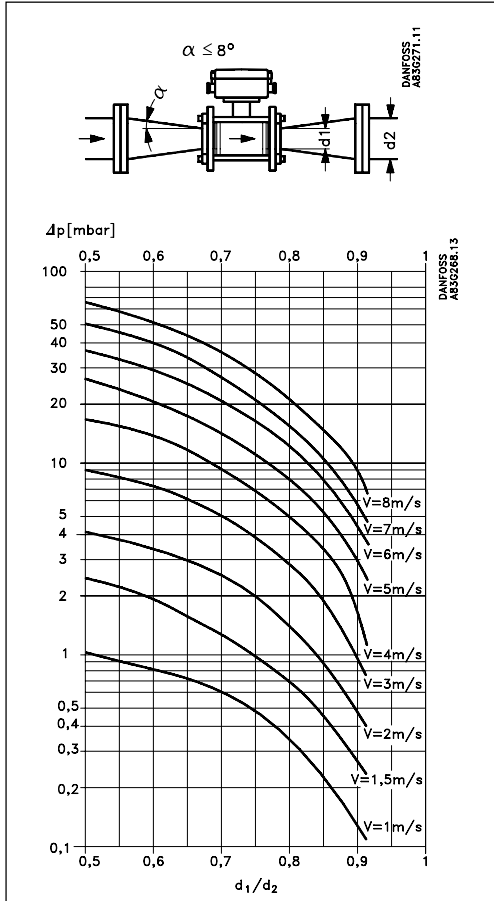

The flowmeter can be installed between two reducers (e.g. DIN 28545). Assuming that at 8° the following pressure drop curve applies. The curves are applicable to water.

Example:

A flow velocity of 3 m/s (V) in a sensor with a diameter reduction from DN 100 to DN 80 ($d_1/d_2 = 0.8$) gives a pressure drop of 2.9 mbar.

Compact/remote installation

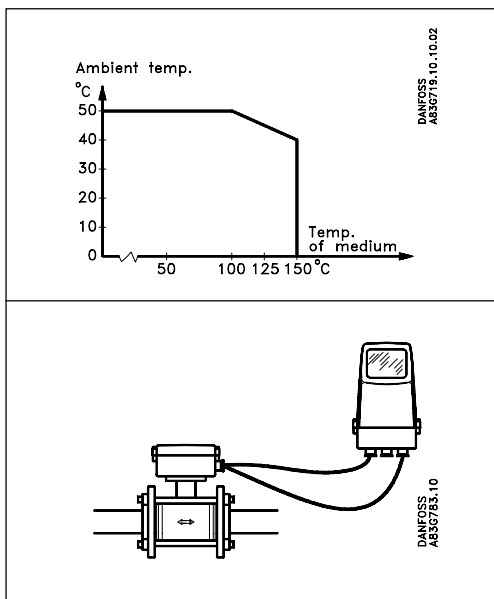

The sensor and signal converter can be installed either compact or remote.

With **compact** installation the temperature of medium must be according to the graph.

With **remote** installation, the cable length and type described under "Technical data", section 2 must be used.

3.4 Cleaning unit

The Danfoss cleaning unit can be used with MAG 5000 or 6000 in 19" insert version. The cleaning unit can be used in applications where the liner material and subsequently the electrodes may be coated by deposits. If the coating is electrically insulating, the electrode signal will be reduced. If the coating is electrically conductive, the electrode signal will be partly short circuited and in both cases the accuracy of the meter will decrease (dependent on the type and thickness of the coating).

Note!

The cleaning unit cannot be used for inflammable or explosive media!

Mode of operation

The cleaning unit cleans the electrodes electro-chemically by applying a voltage to the electrodes for approx. 60 sec. While cleaning, the signal converter stores and holds the last measured flow reading on the display and also the signal outputs. After an additional pausing period of 60 sec. the flowmeter resumes normal measurement and the cleaning is now completed.

The relay in the signal converter activates the cleaning cycle. In the relay output menu (under cleaning) the cleaning interval can be set between 1 hour and 24 hours.

Cleaning should only take place with liquid in the pipe. This can be detected via the empty pipe function. It is therefore recommended to select "empty pipe detection" ON when using the cleaning unit.

The cleaning sequence can also be controlled manually through the electrical input of the signal converter. Before this is done, ensure that the measuring pipe is full.

AC-cleaning

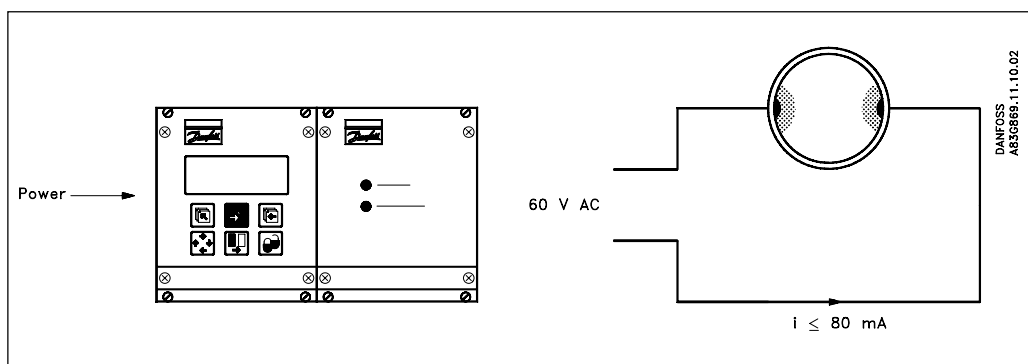

AC-cleaning is used to remove fatty deposits on the electrodes. These fatty deposits are seen in waste water applications, in abattoirs and water applications with oil residuals. During the cleaning process, the surface of the electrodes get warmer, which tends to soften grease particles and the gas bubbles generated mechanically lift deposits away from the surface of the electrodes.

DC-cleaning

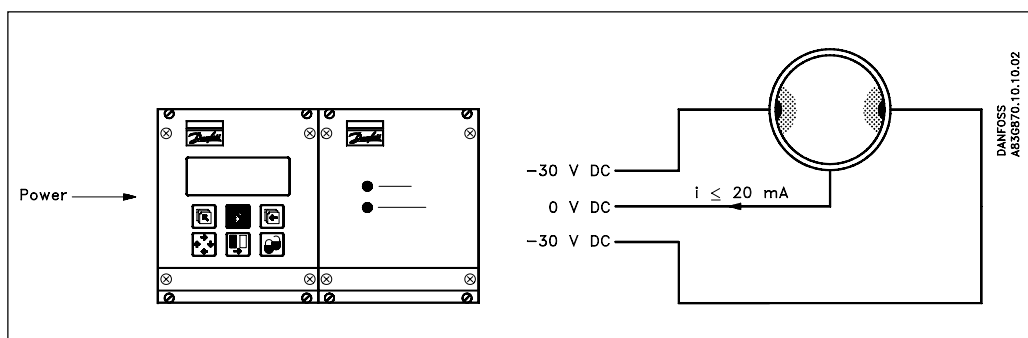

DC-cleaning is used to eliminate electrically conductive deposits in the measuring pipe influencing the measuring accuracy.

Particularly in district heating applications an electrically conductive deposit (magnetite) may occur and short circuit the electrode signal. In this case the accuracy of the meter decreases and the signal/noise conditions of the meter become inferior. The problem only arises if the conductivity of the water is less than approx. 250 μS/cm.

During DC-cleaning, electrolysis takes place where the flow of electrons removes the particle deposits from the electrode area.

Do not use DC-cleaning on sensors with tantalum electrodes.

3.5
Custody transfer approval

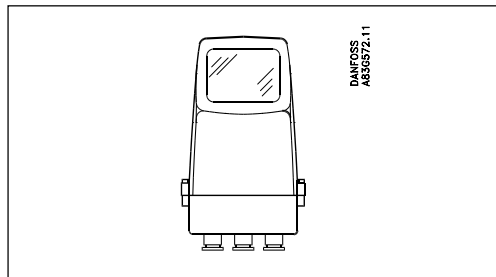

The MAG 6000 signal converter can be supplied in a version tested and approved for custody transfer. The internal counter can accordingly be used for charging.

This requires verification, sealing and setting of the signal converter together with the sensor for a specific flow range. After sealing the data on the signal converter must not be changed.

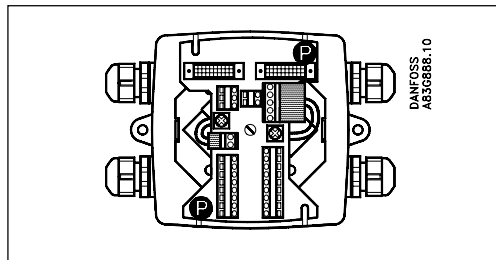

The sealing of the signal converter is done by placing sealing marks on the signal converter and on the connection plate in the terminal box.

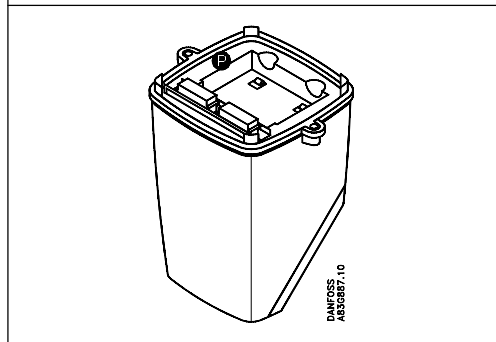

3.6
Ex installations

Signal converters

The signal converter can be one of the following types:

MAG 5000/6000 19" with safety barrier (ia/ib) for separate mounting in safe area

Approval [EEx ia/ib] IIB. The safety barrier is to be used with sensors MAG 1100 Ex and MAG 3100 Ex, DN 6 - 300. When this safety barrier is used, the coil circuit is intrinsic safety "ib" and the electrode circuit is intrinsic safety "ia".

MAG 5000/6000 19" with safety barrier (ia) for separate mounting in safe area

Approval [EEx ia] IIC. The safety barrier is to be used with sensors MAG 3100 Ex, DN 350 - 2000. When the safety barrier is used, the coil circuit is increased safety "e" and the electrode circuit is intrinsic safety "ia".

Sensors

The sensors can be one of the following type.

MAG 1100 Ex for mounting in Ex areas

Approval EEx [ia/ib] IIB T4...T6. DEMKO no. 97D.121909X. DN 6 - 100.

MAG 3100 Ex for mounting in Ex areas

The sensor carries the approval:

DN 15 - 100 EEx [ia/ib] m IIB T4...T6, DEMKO no. 94C116403X.

DN 125 - 300 EEx [ia/ib] e IIB T4...T6, DEMKO no. 94C115326X.

DN 350 - 2000 EEx e [ia] IIC T3...T6, SIRA no. Ex 92C3107X.

The electrode circuit in the sensors is manufactured to an intrinsically safe category "ia" and the coil circuit to an intrinsically safe category "ib", achieved by an integrated and patented protection circuit. For DN 350 - 2000 the coil circuit is increased safety "e".

Marking

The marking has the following meaning according to European Norm EN 50014.

- E: Certified to CENELEC standard.
- Ex: Designates explosion proof material and indicates that the apparatus has been approved in accordance with a certificate issued.
- i: "Intrinsic safety" is a protection ensuring that the energy in the electric circuit is too small to ignite the explosive atmosphere. There are two categories of intrinsic safety: "ia" and "ib".
 - ia: In intrinsic safety category "ia", the circuit must remain safe, even in the event of two simultaneous errors occurring that are independent of one another.
 - ib: In intrinsic safety category "ib" the circuit must remain safe if one error occurs.
- d: The enclosure of the of the signal converter is so strong that it can resist an explosion inside the enclosure. The enclosure is dimensioned in a way so that an explosion will not effect the surroundings.
- e: "Increased safety" is a constructional safeguard which ensures the apparatus does not contain normally arcing or sparking devices, or hot surfaces that will cause ignition.
- I: Designates that the apparatus may be used in all areas (Except mining).
- B: Indicates the gas group in which the unit may be used.

T4...T6 The temperature class describes the maximum temperature which any exposed surface of the equipment may reach. The sensor can have temperature class T3, T4, T5 or T6 depending on the temperature of the media. Please see technical data for the sensor.

T3: Max. surface temperature 200 °C. => (Max. media temperature 180 °C).

T4: Max. surface temperature 135 °C. => (Max. media temperature 120 °C).

T5: Max. surface temperature 100 °C. => (Max. media temperature 90 °C).

T6: Max. surface temperature 85 °C. => (Max. media temperature 75 °C).

4.1 Sensor MAG 1100



MAG 1100, compact/separate

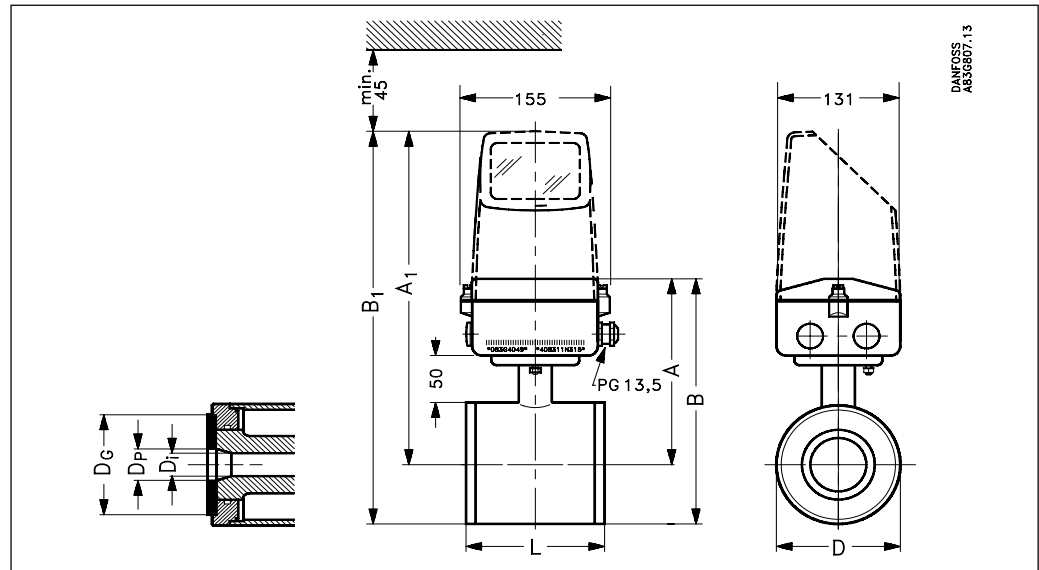

DN	A ¹⁾ [mm]	B ¹⁾ [mm]	A ₁ [mm]	B ₁ [mm]	D [mm]	D _i (Al ₂ O ₃) [mm]	D _p [mm]	D _G [mm]	Weight ²⁾ [kg]
6	156	181	309	334	48.3	6	17.3	34	2.2
10	156	181	309	334	48.3	10	17.3	34	2.2
15	156	181	309	334	48.3	15	17.3	40	2.2
25	164	196	317	349	63.4	25	28.5	56	2.7
40	176	218	329	371	84.0	40	43.4	75	3.4
50	184	235	337	388	101.6	50	54.5	90	4.2
65	194	254	347	407	120.0	65	68.0	112	5.5
80	200	266	353	419	133.0	80	82.5	124	7.0
100	213	292	366	445	159.0	100	107.1	150	10.0

1) 13 mm shorter when the AISI terminal box is used. (Ex and high temperature 200°C).

2) With signal converter MAG 5000 or MAG 6000 installed, weight is increased by approx. 0.8 kg.

The total built-in length "L" [mm] before assembling, depends on the gasket selected.

DN	EPDM	Graphite	PTFE(Teflon)	Without gasket	Earthing ring
6	64	66	70	64	77
10	64	66	70	64	77
15	65	66	70	64	77
25	80	81	85	79	92
40	95	96	100	94	107
50	105	106	110	104	117
65	130	131	135	129	142
80	155	156	160	154	167
100	185	186	190	184	197

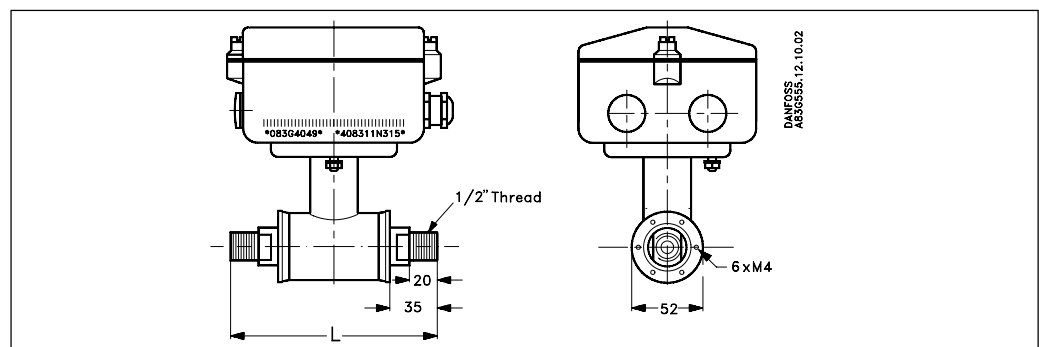

The MAG 1100 DN 6 and DN 10 are prepared for assembly with the 1/2" pipe connection (ISO). The length "L" varies dependent on the gasket choice:

	Without gasket	EPDM	Graphite	Teflon
L [mm]	150	150	152	156

4.2
Sensor MAG 1100 FOOD



MAG 1100 FOOD, compact and separate

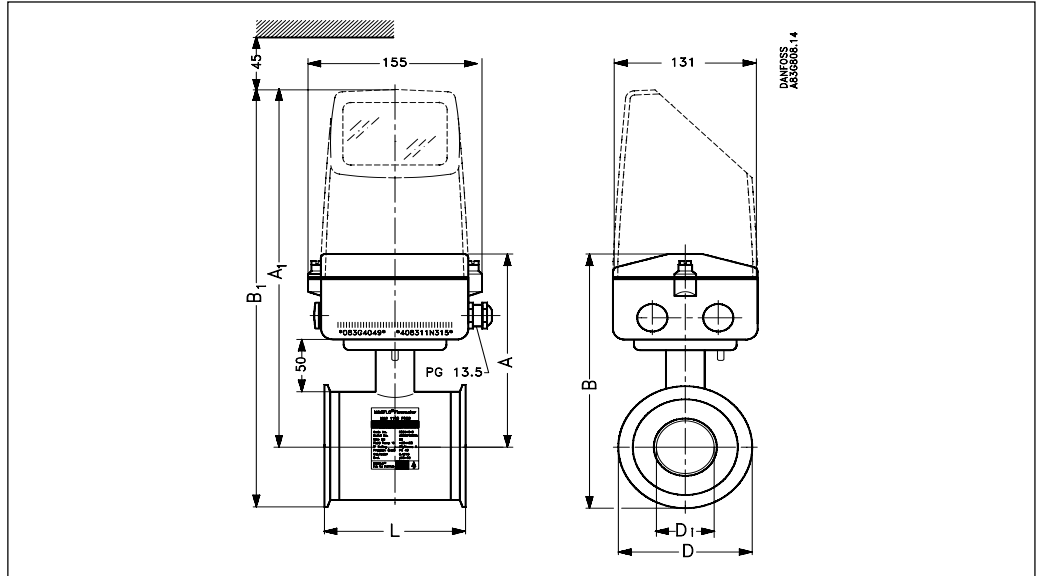

DN	L [mm]	A [mm]	A ₁ [mm]	B [mm]	B ₁ [mm]	D [mm]	D _i (Al ₂ O ₃) [mm]	D _i (PFA) [mm]	Weight ¹⁾ [kg]
10	64	156	309	181	334	64	10	10	2.2
15	64	156	309	181	334	64	15	16	2.2
25	79	164	317	196	349	77.5	25	26	2.7
40	94	176	329	218	371	91	40	38	3.4
50	104	184	337	235	388	119	50	50	4.2
65	131	194	347	254	407	130	65	66	5.5
80	156	200	353	266	419	155	80	81	7.0
100	186	213	366	292	445	183	100	100	10.0

¹⁾ With signal converter MAG 5000 or MAG 6000 installed weight is increased by approx. 0.8 kg.

Built-in length

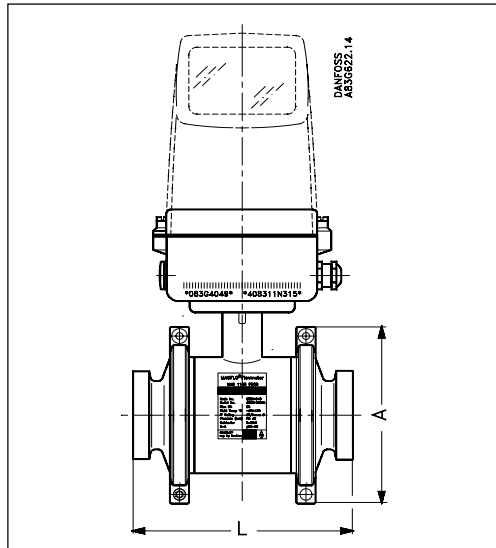

DN	A [mm]	L ¹⁾ [mm]
10	99	146
15	99	146
25	113	161
40	126	176
50	154	186
65	165	223
80	200	258
100	225	288

¹⁾ The total built-in length "L" is independent of the adapter type selected.

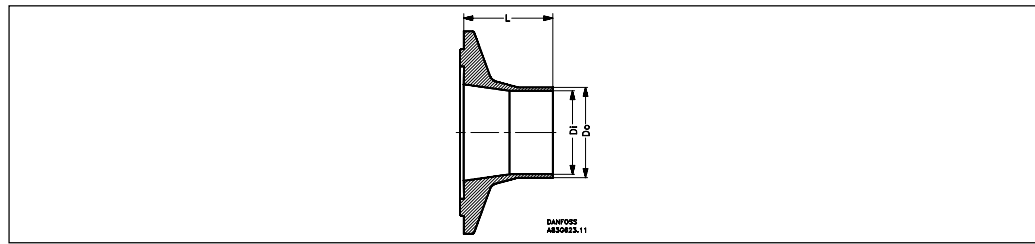
**Accessories
MAG 1100 FOOD**

Adapter DN [mm]	Sensor DN [mm]	L [mm]	Weld-in type									
			DIN 11850		DS/ISO 2037		SMS 3008		BS4825-1		Tri-Clover®	
			Di [mm]	Do [mm]	Di [mm]	Do [mm]	Di [mm]	Do [mm]	Di [mm]	Do [mm]	Di [mm]	Do [mm]
10	10	40	10.0	13.0	10.0	13.0	10.0	13.0	10.0	13.0	-	-
15	15	40	16.0	19.0	16.0	19.0	16.0	19.0	16.0	19.0	-	-
15.9	15	40	-	-	-	-	-	-	-	-	13.5	15.9
20	15	40	20.0	23.0	20.0	23.0	20.0	23.0	20.0	23.0	-	-
25	25	40	-	-	22.6	25.6	22.6	25.6	22.6	25.6	-	-
25	25	40	26.0	29.0	-	-	-	-	-	-	-	-
28	25	40	-	-	25.6	28.6	-	-	-	-	-	-
32	25	40	-	-	-	-	29.6	32.0	-	-	-	-
32	25	40	32.0	35.0	-	-	-	-	-	-	-	-
33.7	25	40	-	-	31.3	34.3	31.3	34.3	-	-	-	-
38	40	40	-	-	35.6	38.6	35.6	38.6	35.6	38.6	35.6	38.6
40	40	40	-	-	37.6	40.6	-	-	-	-	-	-
40	40	40	38.0	40.0	-	-	-	-	-	-	-	-
50	50	40	-	-	48.6	51.6	48.6	51.6	48.6	51.6	48.6	51.6
50	50	40	50.0	53.0	-	-	-	-	-	-	-	-
63.5	65	45	-	-	60.3	64.1	60.3	64.1	60.3	64.1	60.3	64.1
65	65	45	66.0	70.0	-	-	-	-	-	-	-	-
70	65	45	-	-	66.8	70.6	-	-	-	-	-	-
76	65	45	-	-	-	-	72.0	76.0	-	-	-	-
76.1	80	50	-	-	72.9	76.7	72.9	76.7	72.9	76.7	72.9	76.7
80	80	50	81.0	85.0	-	-	-	-	-	-	-	-
88.9	80	50	-	-	84.9	89.8	84.9	89.8	-	-	-	-
100	100	50	100	104	-	-	-	-	-	-	-	-
101.6	100	50	-	-	97.6	102.5	97.6	102.5	97.6	102.6	97.6	102.6
114.3	100	50	-	-	110.3	115.6	110.3	115.6	110.3	115.6	-	-

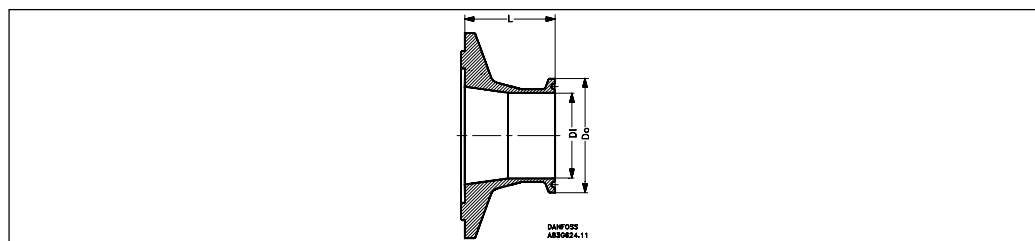

Adapter DN [mm]	Sensor DN [mm]	L [mm]	Clamp type									
			DIN 32676		ISO 2852		SMS 3016		BS4825-3		Tri-Clamp®	
			Di [mm]	Do [mm]	Di [mm]	Do [mm]	Di [mm]	Do [mm]	Di [mm]	Do [mm]	Di [mm]	Do [mm]
10	10	40	10.0	34.0	10.0	34.0	10.0	34.0	-	-	-	-
15	15	40	16.0	34.0	16.0	34.0	16.0	34.0	-	-	-	-
20	15	40	20.0	34.0	20.0	34.0	-	-	-	-	-	-
25	25	40	-	-	22.6	50.5	22.6	50.5	22.6	50.5	22.6	50.5
25	25	40	26.0	50.5	26.0	50.5	-	-	-	-	-	-
33.7	25	40	31.3	50.5	31.3	50.5	31.3	50.5	-	-	-	-
38	40	40	-	-	35.6	50.5	35.6	50.5	35.6	50.5	35.6	50.5
40	40	40	38.0	50.5	38.0	50.5	-	-	-	-	-	-
50	50	40	50.0	64.0	-	-	-	-	-	-	-	-
51	50	40	-	-	48.6	64.0	48.6	64.0	48.6	64.0	48.6	64.0
63.5	65	45	-	-	60.3	77.5	60.3	77.5	60.3	77.5	60.3	77.5
65	65	45	66.0	91.0	-	-	-	-	-	-	-	-
76.1	80	50	-	-	72.9	91.0	72.9	91.0	72.9	91.0	72.9	91.0
80	80	50	81.0	106.0	-	-	-	-	-	-	-	-
100	100	50	100	119.9	-	-	-	-	-	-	-	-
101.6	100	50	-	-	97.6	119.0	97.6	119.0	97.6	119.0	97.6	119.0

Tri-Clover® and Tri-Clamp® is a registered trademark for Ladish Co.

Accessories
MAG 1100 FOOD

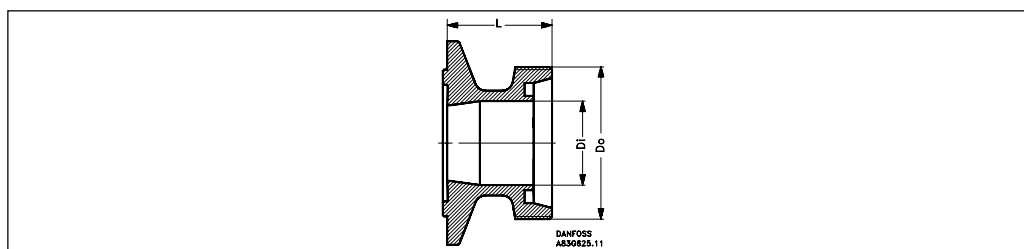

Adapter DN [mm]	Sensor DN [mm]	L [mm]	Threaded type	
			DIN 11851	
			Di [mm]	Do [mm]
10	10	40	10.0	28.0
15	15	40	16.0	34.0
20	15	40	20.0	44.0
25	25	40	26.0	52.0
32	25	40	32.0	58.0
40	40	40	38.0	65.0
50	50	40	50.0	78.0
65	65	45	66.0	95.0
80	80	50	81.0	110.0
100	100	50	100.0	130.0

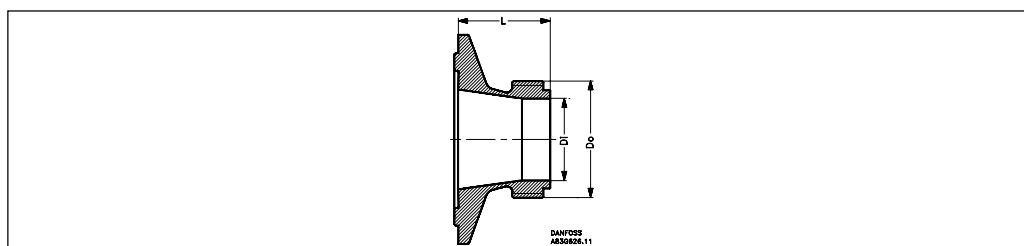

Adapter DN [mm]	Sensor DN [mm]	L [mm]	Threaded type					
			ISO 2853		SS 3351		BS 4825-4 (IDF)	
			Di [mm]	Do [mm]	Di [mm]	Do [mm]	Di [mm]	Do [mm]
25	25	40	22.6	37.0	22.6	37.0	22.6	37.0
38	40	40	35.6	51.0	35.6	51.0	35.6	51.0
51	50	40	48.6	64.0	48.6	64.0	48.6	64.0
63.5	65	45	60.3	78.0	60.3	78.0	60.3	78.0
76.1	80	50	72.9	91.0	72.9	91.0	72.9	91.0
101.6	100	50	-	-	-	-	97.6	126.0
101.6	100	50	97.6	118.0	97.6	118.0	-	-

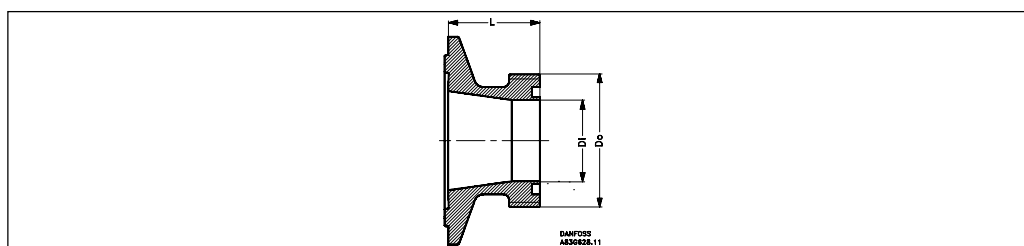

Adapter DN [mm]	Sensor DN [mm]	L [mm]	Threaded type	
			SMS 1145	
			Di [mm]	Do [mm]
25	25	40	22.6	40.0
32	25	40	29.6	48.0
38	40	40	35.6	60.0
51	50	40	48.6	70.0
63.5	65	45	60.3	85.0
76	65	45	72.0	98.0

4.3
Sensor MAG 3100 and
MAG 3100 W

MAG 3100 & MAG 3100 W, compact/separate

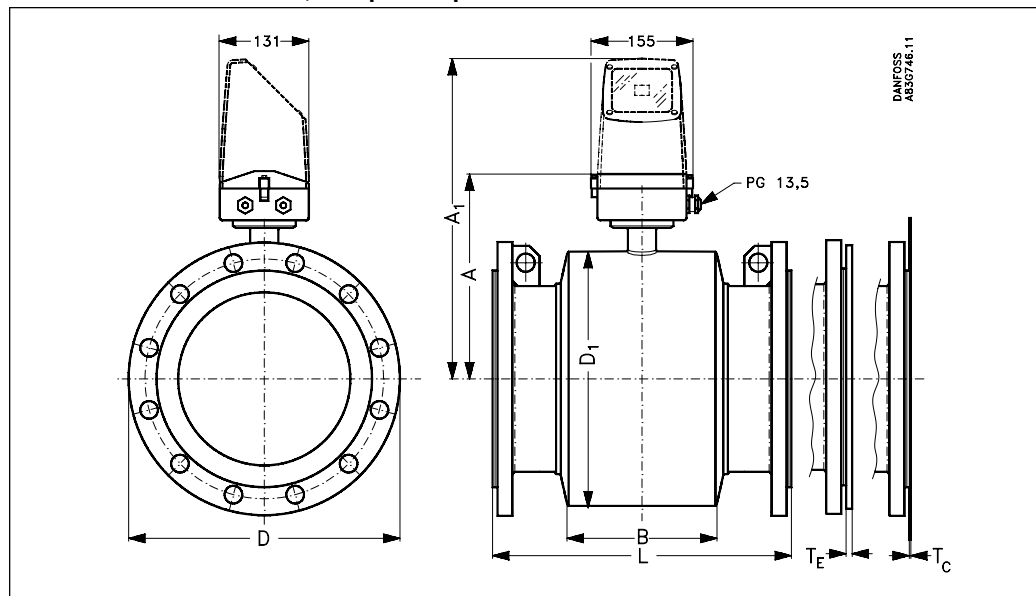

D & W

DN	A ¹⁾	A ₁	B	D ₁	L ²⁾												T _C ³⁾	T _E ³⁾	Weight ⁴⁾
					DIN 2501/BS 4504					BS 1560/ANSI 16.5		BS 10 AS 2129 D & E AS 4087 Class 14	JIS B 2220		AWWA C-207 Class D				
					PN 6, 10, 16	PN 25	PN 40	PN 64	PN 100	Class 150	Class 300		10K	16K					
[mm]	[mm]	[mm]	[mm]	[mm]	[mm]	[mm]	[mm]	[mm]	[mm]	[mm]	[mm]	[mm]	[mm]	[mm]	[mm]	[mm]	[mm]	[kg]	
15	187	338	59	104	200	200	200	-	-	200	200	200	-	-	-	-	6	4	
25	187	338	59	104	200	200	200	-	260	200	200	200	-	-	-	1.2	6	5	
40	197	348	82	124	200	200	200	-	280	200	200	200	-	-	200	1.2	6	8	
50	205	356	72	139	200	200	200	276	300	200	200	200	200	200	-	1.2	6	9	
65	212	363	72	154	200	200	200	320	350	200	272	200	200	200	-	1.2	6	11	
80	222	373	72	174	200	272	272	323	340	272	272	200	200	272	-	1.2	6	12	
100	242	393	85	214	250	250	250	380	400	250	310	250	250	280	-	1.2	6	16	
125	255	406	85	239	250	250	250	420	450	250	335	250	250	250	-	1.2	6	19	
150	276	427	85	282	300	300	300	415	450	300	300	300	300	300	-	1.2	6	27	
200	304	455	137	338	350	350	350	480	530	350	350	350	350	350	-	1.2	8	40	
250	332	483	137	393	450	450	450	550	620	450	450	450	450	450	-	1.2	8	60	
300	357	508	137	444	500	500	500	600	680	500	500	500	500	500	-	1.6	8	80	
350	362	513	270	451	550	550	550	700	800	550	550	550	550	550	-	1.6	8	110	
400	387	538	270	502	600	600	600	750	-	600	600	600	600	600	-	1.6	10	125	
450	418	569	310	563	600	600	600	-	-	600	640	600	600	600	-	1.6	10	175	
500	443	594	350	614	625	625	680	-	-	680	730	625	625	680	-	1.6	10	200	
600	494	645	430	715	750	750	750	-	-	820	860	750	750	820	-	1.6	10	300	
700	544	695	500	816	875	-	-	-	-	-	-	875	875	875	875	2.0	-	350	
750	571	722	556	869	-	-	-	-	-	-	-	937	937	937	937	2.0	-	-	
800	606	757	560	927	1000	-	-	-	-	-	-	1000	1000	1000	1000	2.0	-	475	
900	653	804	630	1032	1125	-	-	-	-	-	-	1125	1125	1125	1125	2.0	-	560	
1000	704	906	670	1136	1250	-	-	-	-	-	-	1250	1250	1250	1250	2.0	-	700	
1100	755	906	770	1238	1375	-	-	-	-	-	-	-	-	-	-	2.0	-	-	
1200	810	961	792	1348	1500	-	-	-	-	-	-	1500	-	1500	1500	2.0	-	1250	
1400	925	1076	1000	1675	1750	-	-	-	-	-	-	-	-	-	-	3.0	-	1753	
1500	972	1123	1020	1672	-	-	-	-	-	-	-	1875	-	-	1875	3.0	-	-	
1600	1025	1176	1130	1915	2000	-	-	-	-	-	-	-	-	-	-	3.0	-	2341	
1800	1123	1274	1250	1974	2250	-	-	-	-	-	-	-	-	-	-	3.0	-	3253	
2000	1223	1374	1375	2174	2500	-	-	-	-	-	-	-	-	-	-	3.0	-	4060	

1) 13 mm shorter with AISI terminal box (Ex and high temperature)

2) When earthing flanges are used the thickness of the earthing flange must be added to the built-in length

3) T_C = Type C grounding ring, T_E = Type E grounding ring

4) Weights are approx and for PN 16 without signal converter.

D = Outside diameter of flange, see flange tables

Eathing/protection flange

Type C

Type E

DN	t ₁ [mm]	t ₂ [mm]	Weight [kg]
25-250	1.2	15	0.03-0.4
300-600	1.6	20	0.6-2.6
700-1200	2.0	25	3-5
1400-2000	3	40	9-16

DN	t ₁ [mm]	Weight [kg]
15	6	0.07
25-150	6	0.3-1.4
200-350	8	1.7-4.1
400-600	10	6.5-13.0

Type C flanges for liners of neoprene, EPDM, polyurethane, linatex® and ebonite.

Type E flanges for liners of PTFE.

MAG 3100 high temperature (PTFE) is always equipped with 2 pcs. type E earthing flanges.

4.4
Signal converter
Compact polyamid

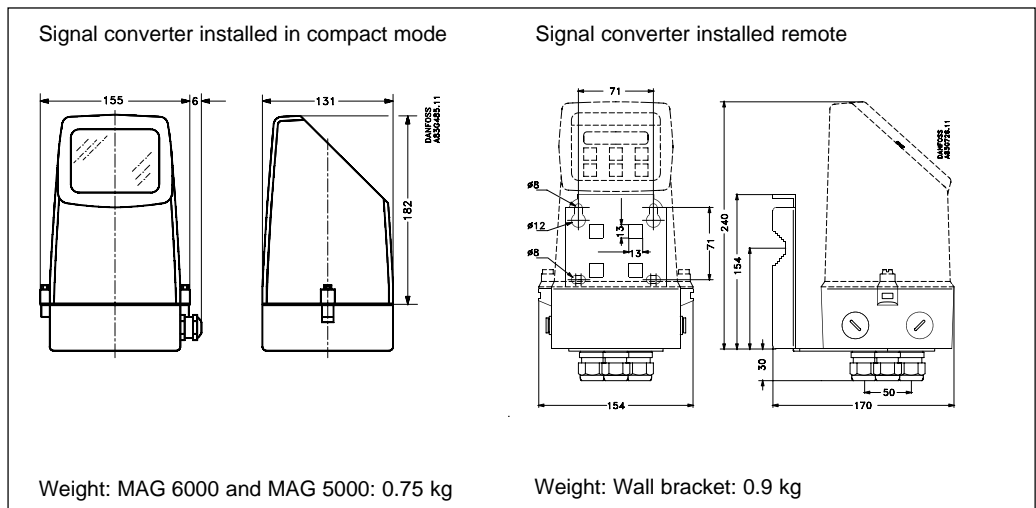

D & W

19" insert, standard unit

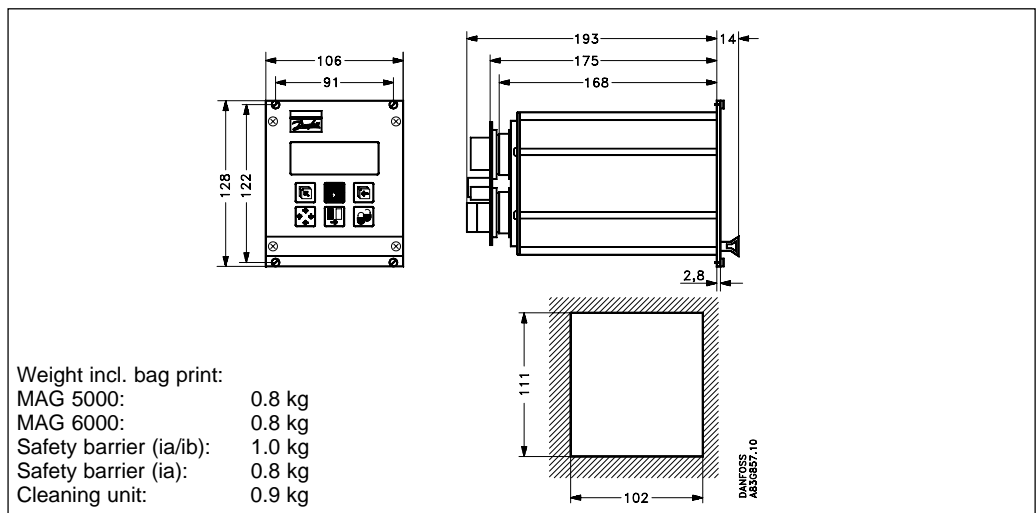

Wall mounting box 21 TE

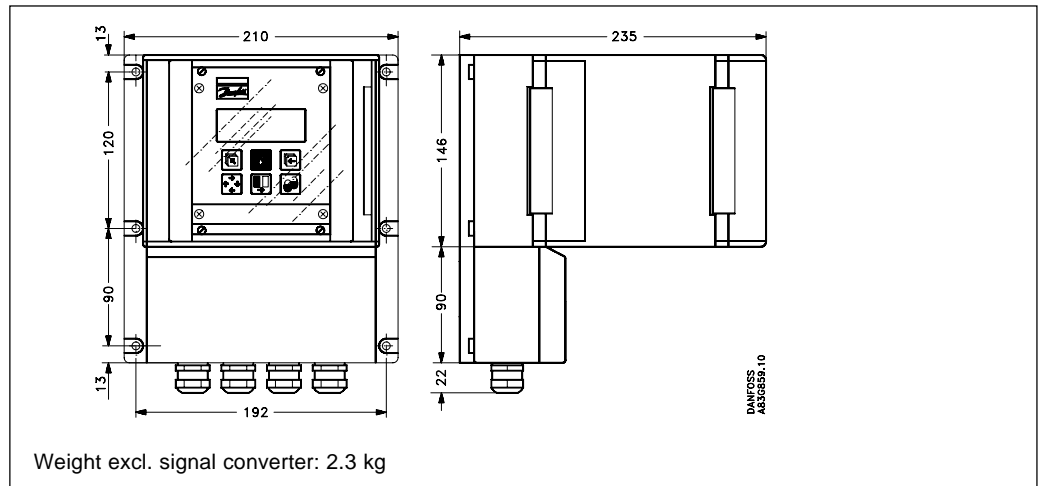

Wall mounting box 42 TE

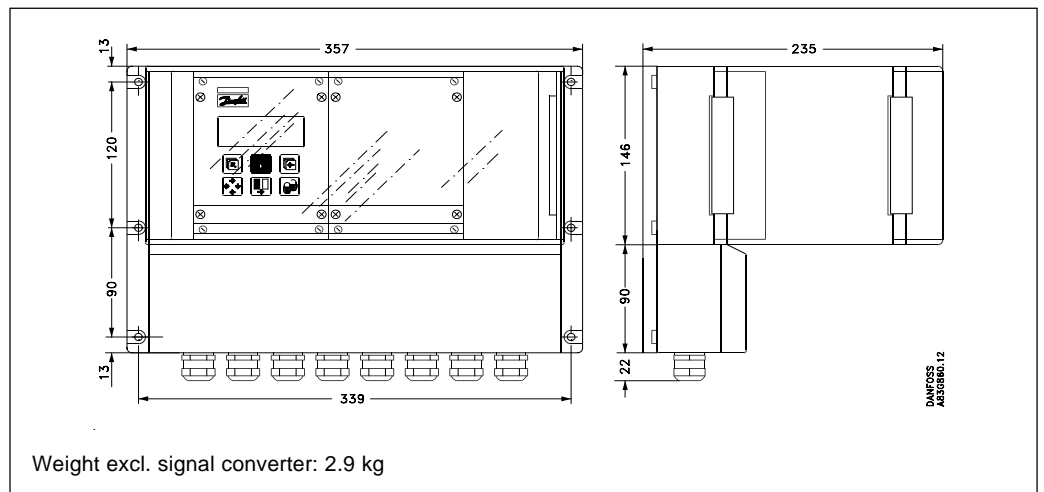

Panel front unit 21 TE

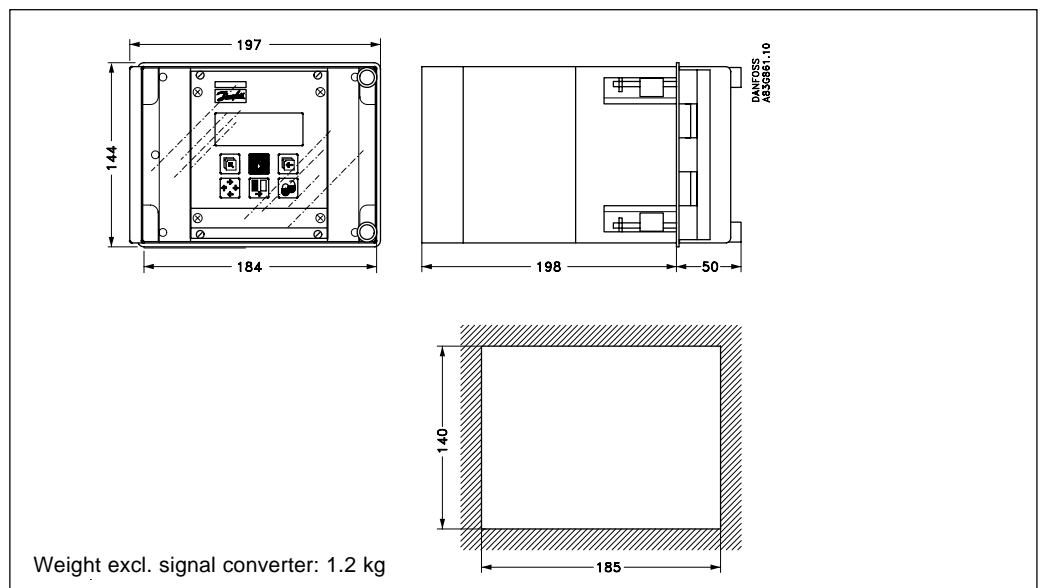

Panel front unit 42 TE

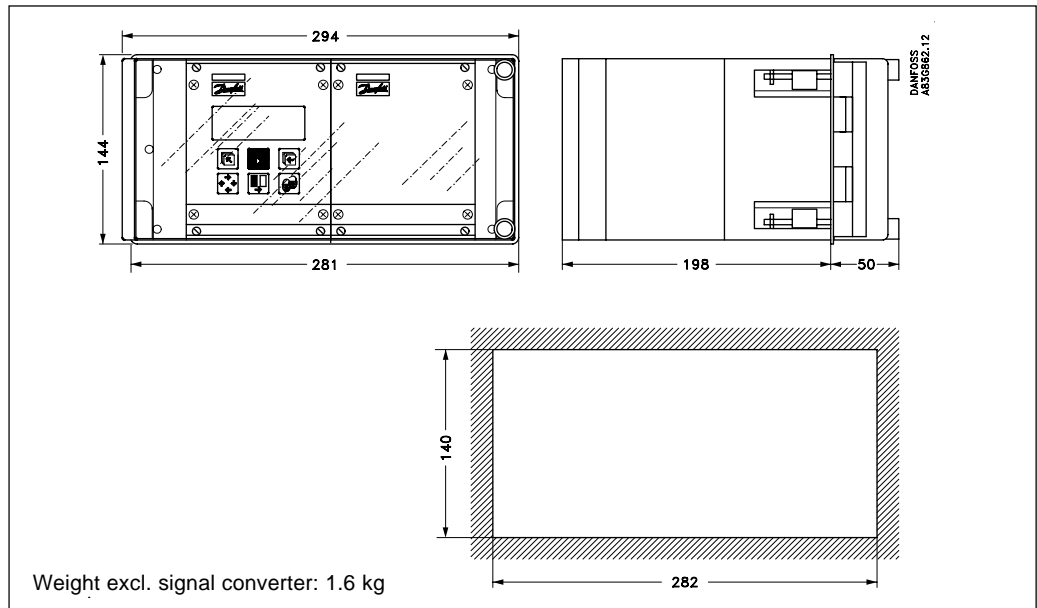

D & W

Back of panel unit 21 TE

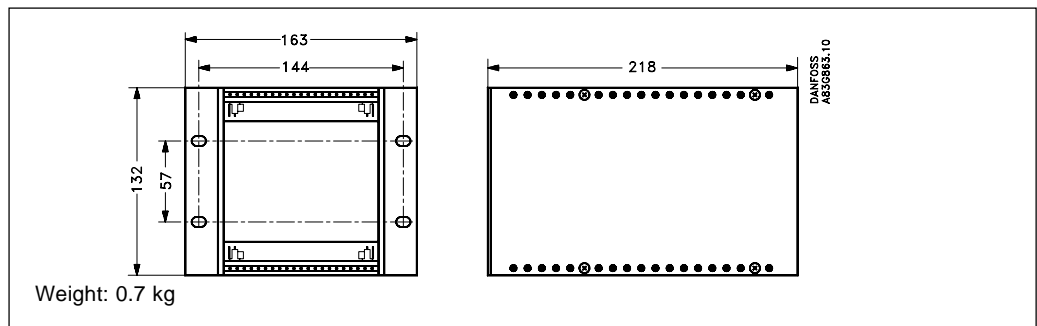

Back of panel unit 42 TE

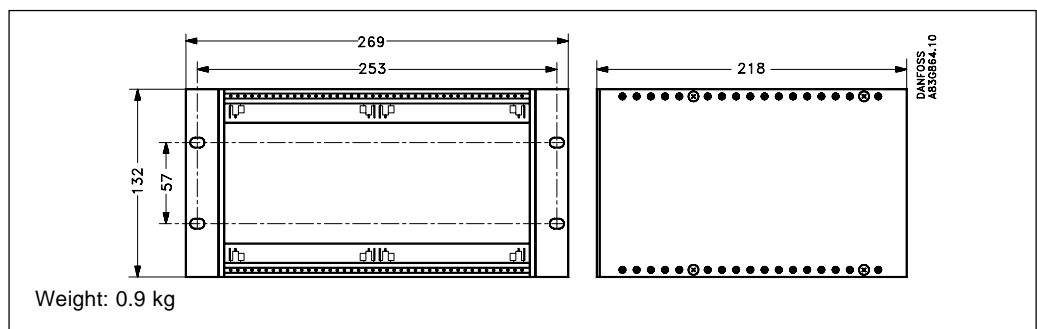

5.1 Potential equalization

To obtain optimum results from the measuring system the sensor's chassis point/housing must have the same electrical potential as the liquid being measured.

MAG 1100

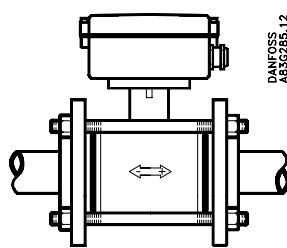
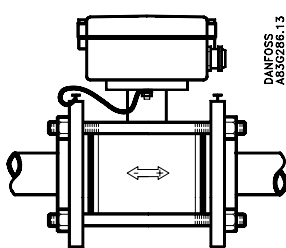
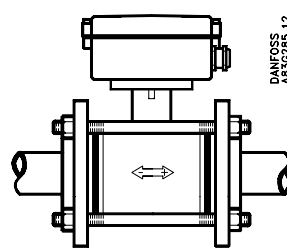
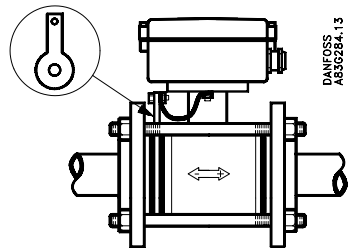
	Graphite gaskets	EPDM or PTFE gaskets
Electrically conductive piping	 <p>A: Potential equalization with electrically conductive graphite gaskets</p>	 <p>B: Potential equalization using earth strap supplied.</p>
Electrically non-conductive piping	 <p>C: Potential equalization with electrically conductive graphite gaskets</p>	 <p>D: Potential equalization using separate potential equalization ring</p>

MAG 1100 FOOD

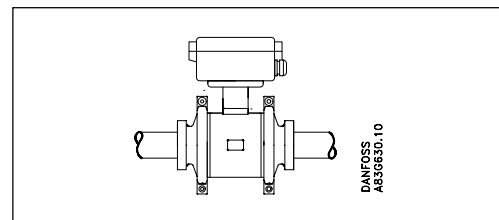

The sensor must be installed between two adapters. Potential equalization with the liquid occurs automatically via these adapters and through the adjacent pipe.

MAG 3100 (With earthing electrodes)

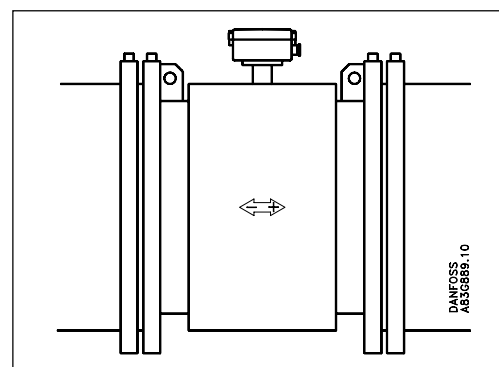

Potential equalisation is carried out with the built-in earthing electrodes. No further action need to be taken.

Sensor

MAG 3100
(Without earthing electrodes)

Electrically conductive piping

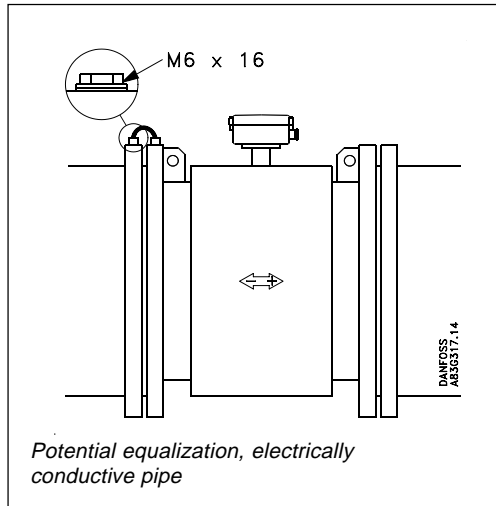

Use an earth straps on one side.

Non-conductive piping

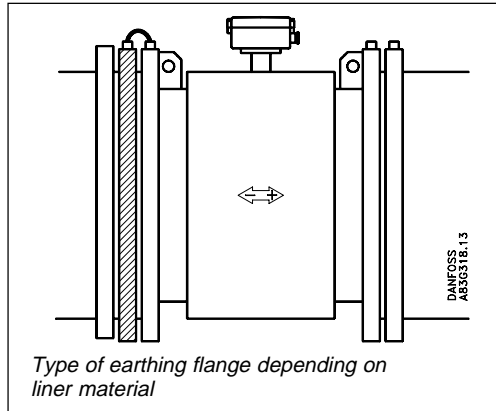

Here an earthing flange is used, placed between flowmeter and the adjacent pipe flange. Selection of earthing flange depends on the medium, liner material and application, see figure.

Liner material	Suitable earthing flange
All except PTFE	Type C
PTFE	Type E

5.2 Inlet protection MAG 3100

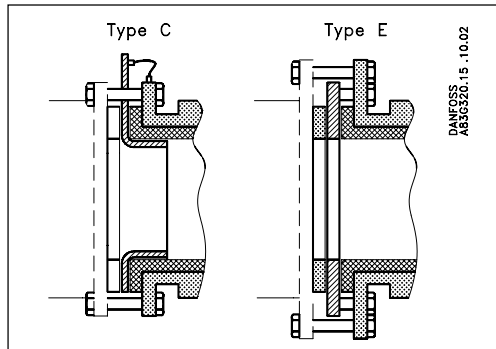

With abrasive liquids flowmeter inlet protection may be necessary. Here type C and E earthing flanges are used.
Type C (for all liners except PTFE) is clamped between the flanges.
Type E (for PTFE liner only) is fitted to the flange.
When using an earthing flange, gaskets must always be used between the adjacent pipe flange and the earthing flange.

5.3 Cathodic protected piping

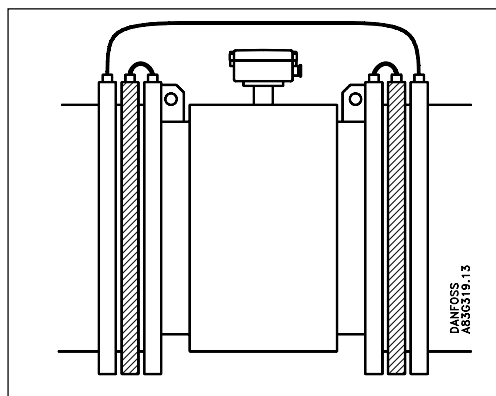

Special attention must be given to systems with cathodic protection.
By compact mounting:
The signal converter must be supplied through an isolation transformer. The terminal "PE" must never be connected.
By remote mounting:
The screen must only be connected at the sensor end via a 1.5 µF condensator. The screen must never be connected at both ends.
By isolated sensor:
If above mentioned connections are unacceptable the sensor must be isolated from the pipe work.

6.1.1
Compact installation
MAG 5000 and MAG 6000
Compact polyamid

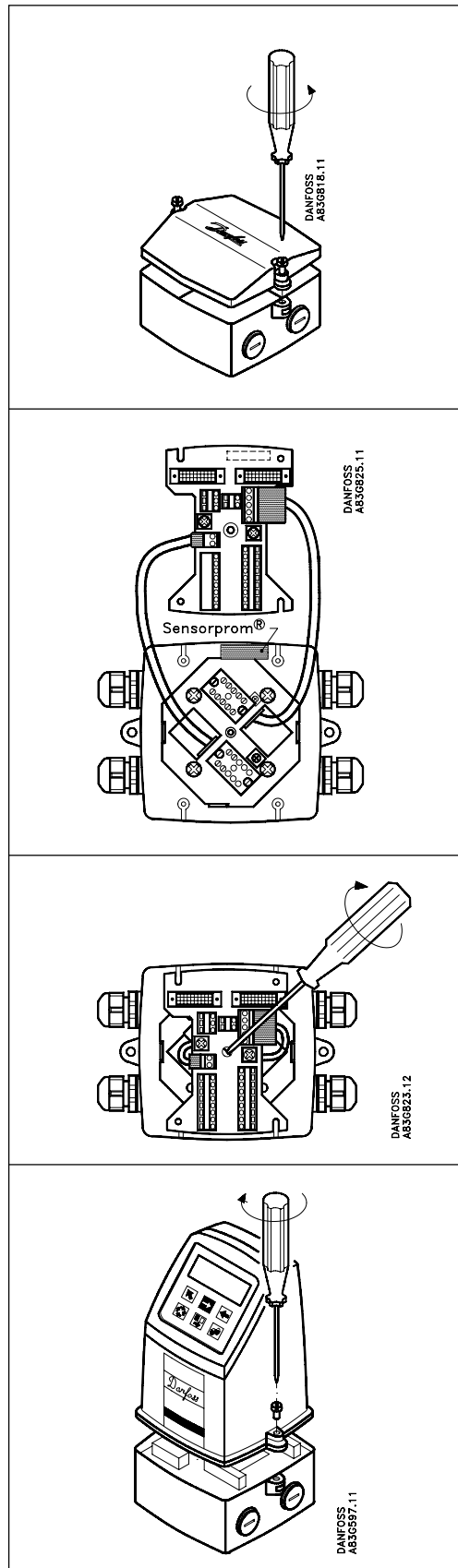

Remove and discard the terminal box lid of the sensor.

Fit the PG 13.5 cable glands for the supply and output cables.

Remove the two black plug assemblies for coil and electrode cables in the terminal box and connect them to their corresponding terminal numbers on the connection plate.

Mount the connection plate in the terminal box. The SENSORPROM® unit connections will then be established automatically when the connection plate is mounted in the terminal box. Tighten the earthing screw in the centre of the connection box properly.

If you have an old terminal box without centre thread, then fix the connection plate with the two diagonal opposite screws.

Fit the supply and output cables respectively and tighten the cable glands to obtain optimum sealing.

Please see the wiring diagram in section 7 for the electrical connections.

Mount the signal converter on the terminal box.

Turning the control pad

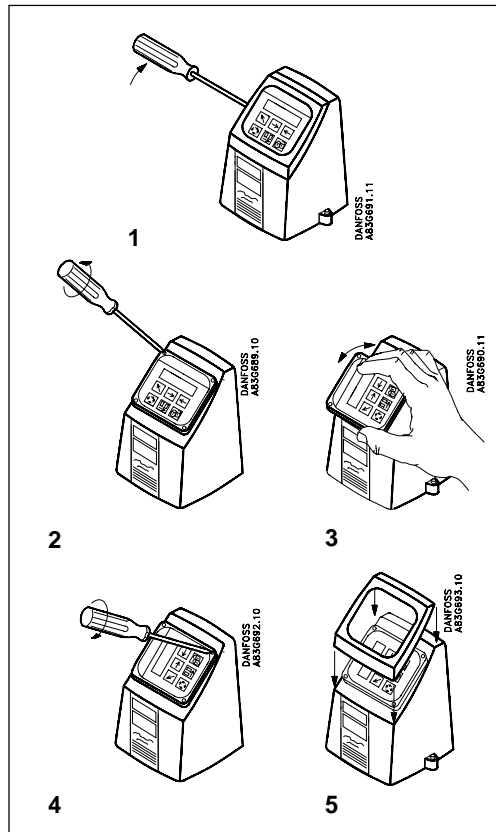

1. Remove the outer frame using a finger-nail or a screwdriver.
2. Loosen the 4 screws retaining the control pad.
3. Withdraw the control pad and turn it to the required orientation.
4. Tighten the 4 screws until a mechanical stop is felt in order to obtain IP 67 enclosure rating.
5. Snap-lock the outer frame onto the control pad (click).

Turning the signal converter

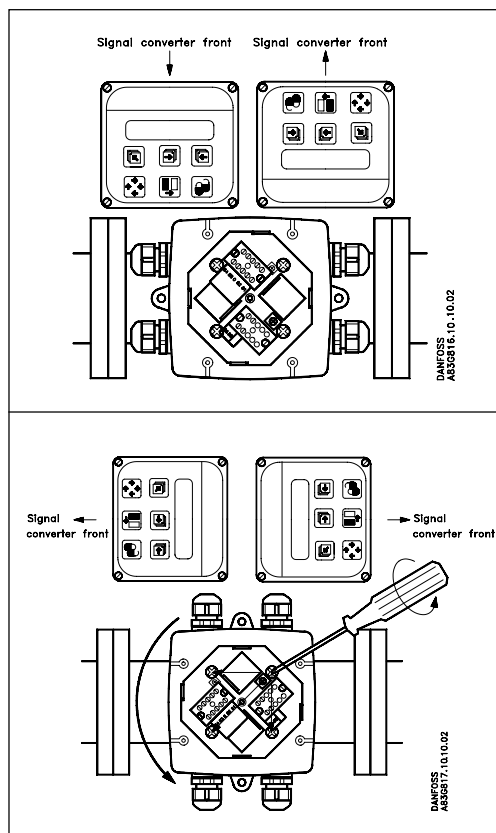

The signal converter can be mounted in either direction as the arrow indicates without turning the terminal box.

The terminal box can be rotated $\pm 90^\circ$ in order to optimize the viewing angle of the signal converter display/keypad:
 Unscrew the four screws in the bottom of the terminal box. Turn the terminal box to the required position and retighten the screws firmly.

6.2.1
Add-on modules
MAG 6000 only

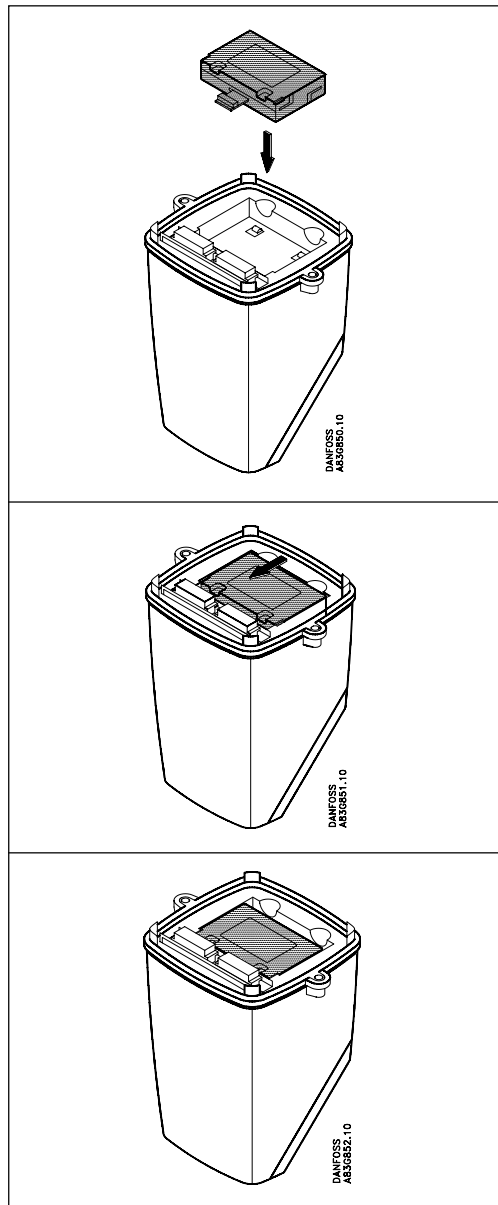

Unpack the add-on modules and locate it in the bottom of the signal converter as shown.

Press the add-on module forwards as far as possible.

The add-on module has now been installed and the signal converter is ready to be installed on the terminal box. Communication to the operator menu and electrically inputs and outputs are automatically established by power on.

6.2.1 Remote installation
At the sensor

Installation of signal conv.

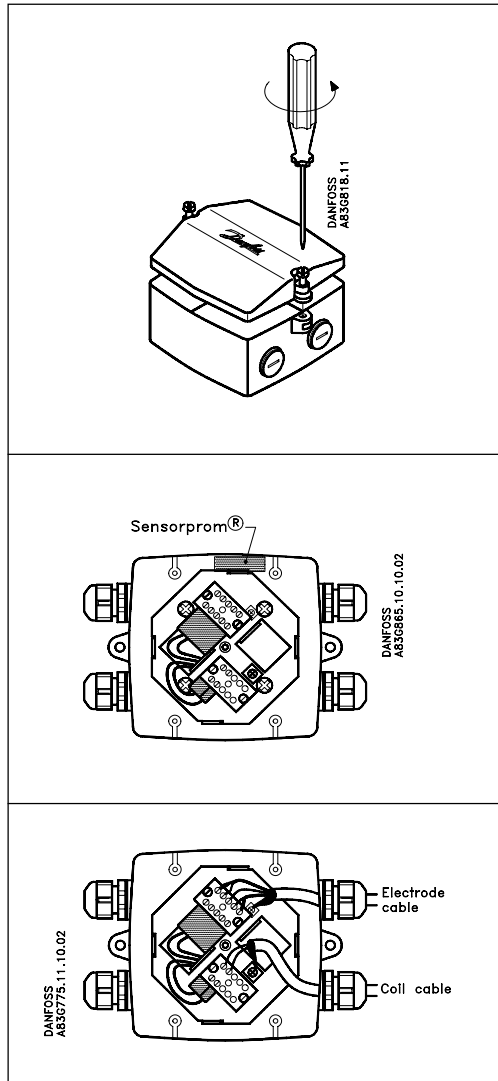

Remove and keep the sensor terminal box lid.

Remove the SENSORPROM® unit and keep it for later use. The SENSORPROM® unit will be mounted on the connection plate to the signal converter.

Fit and connect the electrode and coil cables as shown in section 7 "Electrical connections". The unscreened cable ends must be kept as short as possible. The electrode cable and the coil cable must be kept separate to prevent interference. Tighten the cable glands well to obtain optimum sealing.

IP 68 Applications only

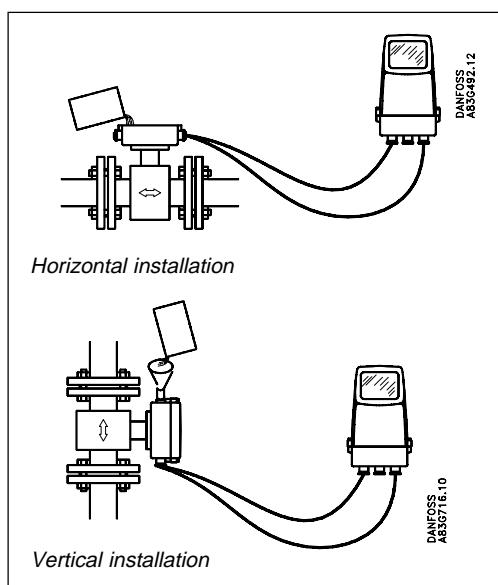

If the sensor is buried or permanently submerged, the terminal box must be encapsulated with silicon dielectric gel.

Mix the two components well and pour the contents into the terminal box. The material is a non-toxic, transparent selfhealing gel which cures in approx. 24 hours.

The gel can be penetrated with test instruments or be removed in case of cable replacement.

6.2.2
Remote installation
Wall mounting

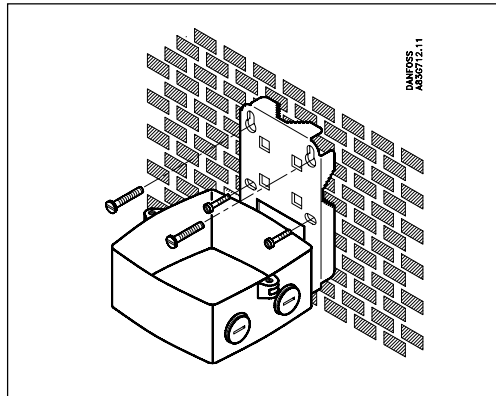

Mount wall bracket on a wall or in the back of a panel.

Vertical pipe mounting

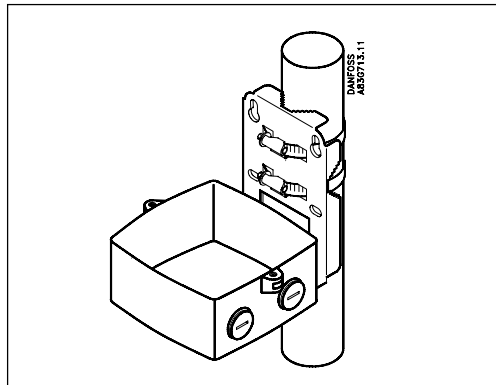

Mount wall bracket on a vertical or horizontal pipe using an ordinary hose clip or a duct strap.

Horizontal pipe mounting

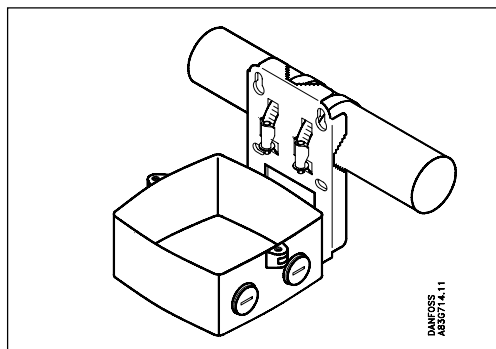

6.2.2 Remote installation
Wall mounting
(continued)

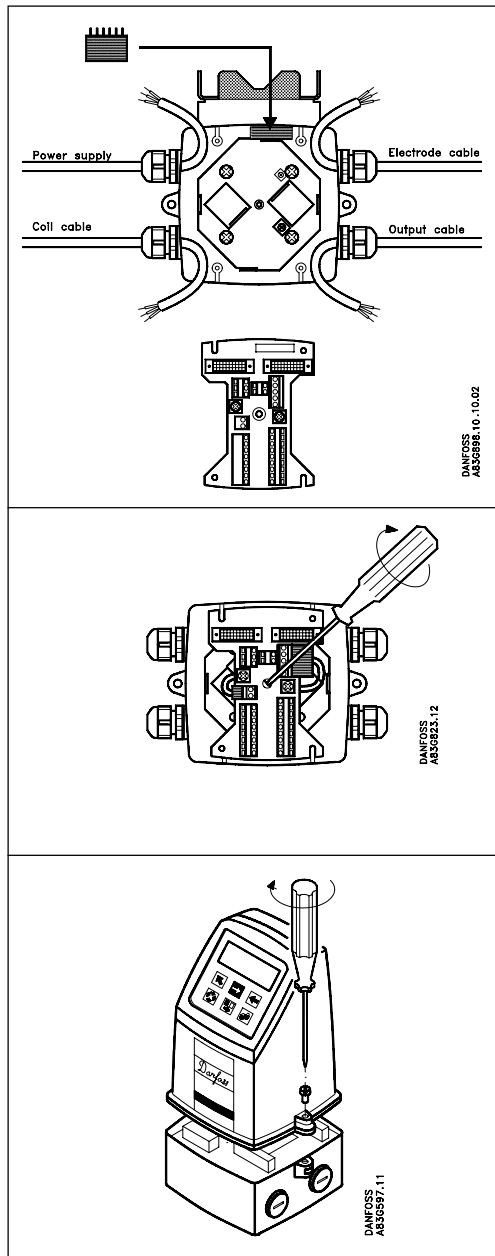

Take the SENSORPROM® memory unit from the sensor. Mount the SENSORPROM® unit in the wall mounting unit as shown. The text on the SENSORPROM® unit **must** turn towards the wall bracket.

Mount the connection plate in the terminal box. Tighten the earthing screw in the centre of the connection box properly. If you have an old wall mounting unit without centre thread, then fix the connection plate with the two diagonal opposite screws.

Fit the coil, electrode, supply and output cables respectively and tighten the cable glands to obtain optimum sealing. Please see the wiring diagram in section 7 for the electrical connections.

Mount the signal converter on the terminal box.

6.2.3
Remote installation
Signal converter in 19"
insert

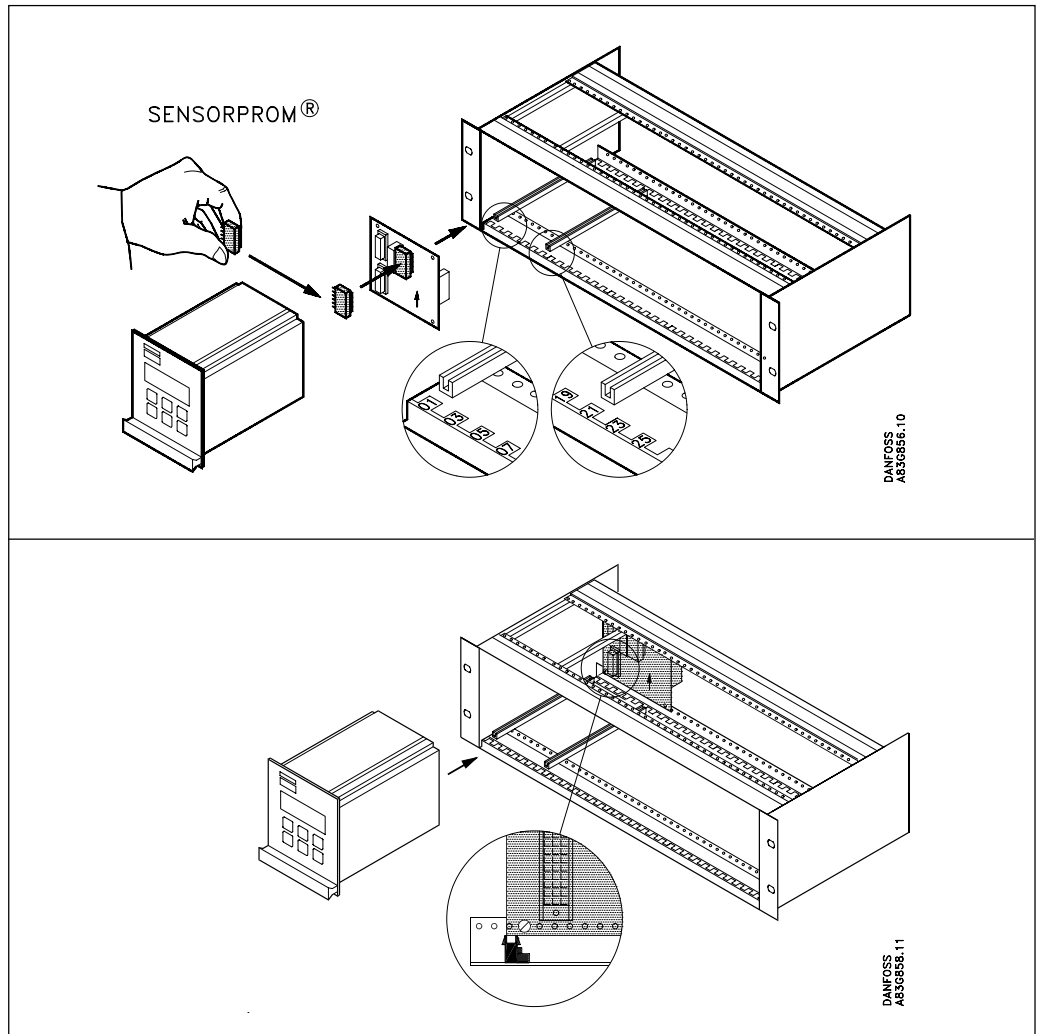

1. Fit the SENSORPROM® memory unit on the connection board supplied with the signal converter. The SENSORPROM® unit is supplied with the sensor in the terminal box.
2. Mount the guide rails in the rack system as shown. Distance between guide rails is 20 TE. Guide rails are supplied with the rack system and not with the signal converter.
3. Mount the connection board as shown. The mounting screw must be installed just in line with the guide rails.
4. Connect the cables as shown under "Electrical connection", section 7.
5. Plug the signal converter into the rack system.

6.2.4
Add-on modules
MAG 6000 only

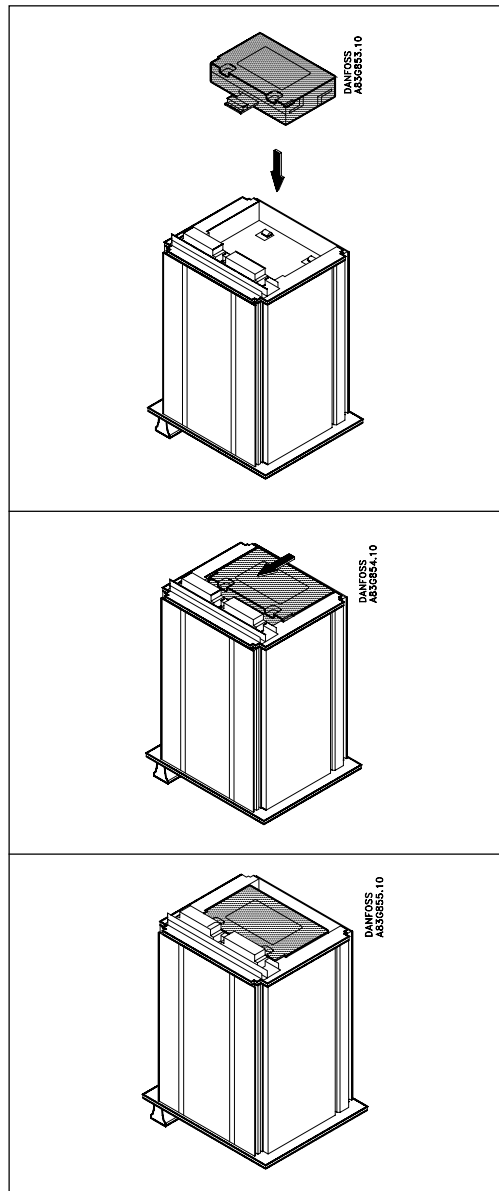

Unpack the add-on modules and locate it in the bottom of the signal converter as shown.

Press the add-on module forwards as far as possible.

The add-on module has now been installed and the signal converter is ready to be installed on the terminal box. Communication to the operator menu and electrically inputs and outputs are automatically established by power on.

6.2.5
Installation in IP 65 wall
mounting enclosure

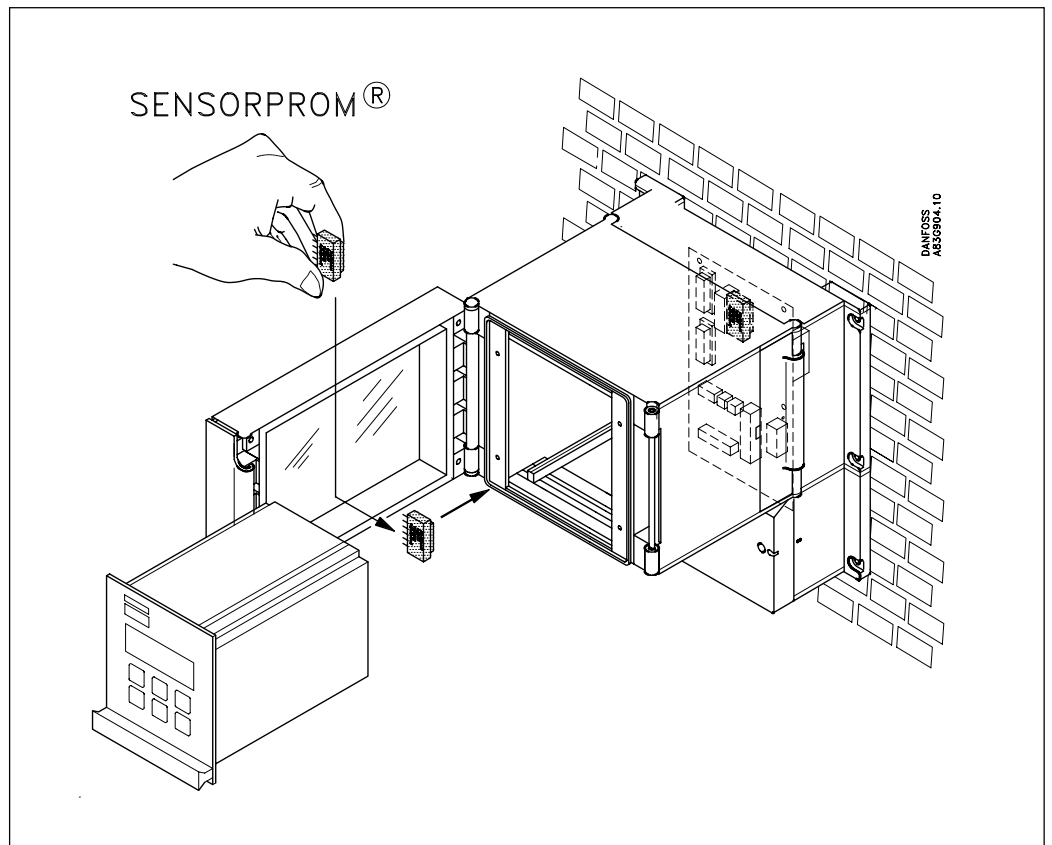

1. Mount the IP 65 enclosure to the wall with four screws.
2. Mount the SENSORPROM® memory unit on the connection board as shown. The SENSORPROM® unit is supplied with the sensor in the terminal box. The connection board for IP 65 wall mounting boxes must be used.
3. Connect the cables to the terminals, see "Electrical connection", section 7.
4. Plug in the signal converter and close the cover.

6.2.6
Installation in IP 65 panel
mounting enclosure
(front of panel)

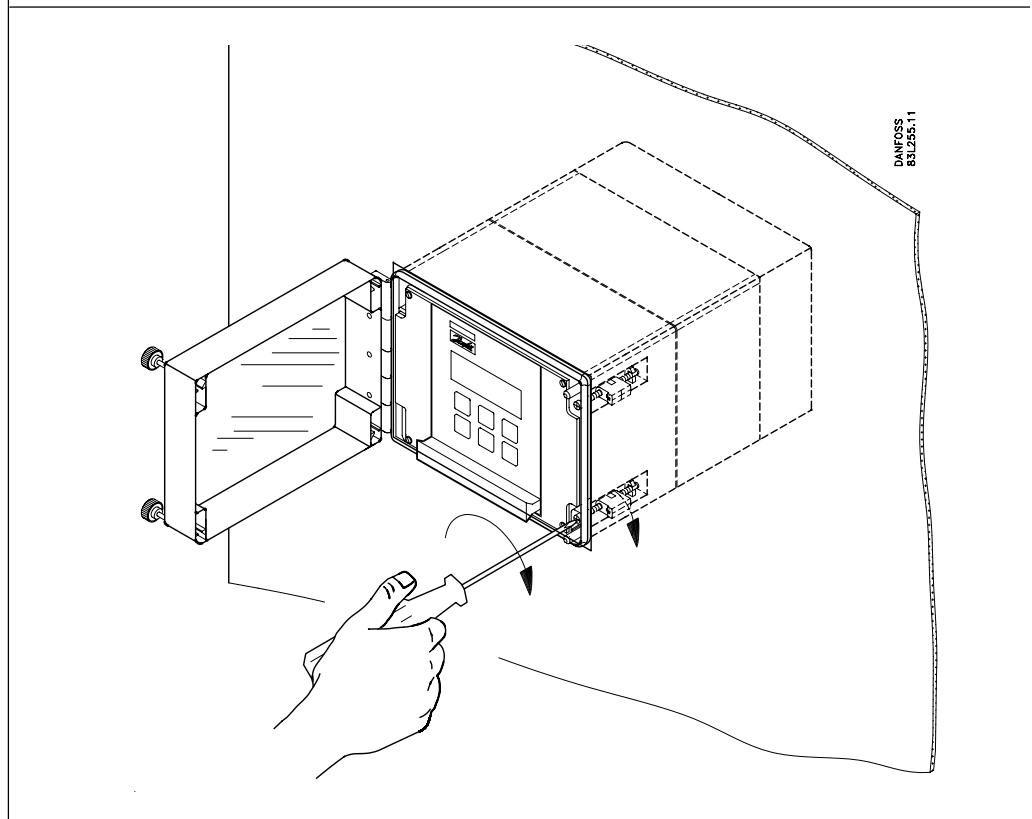
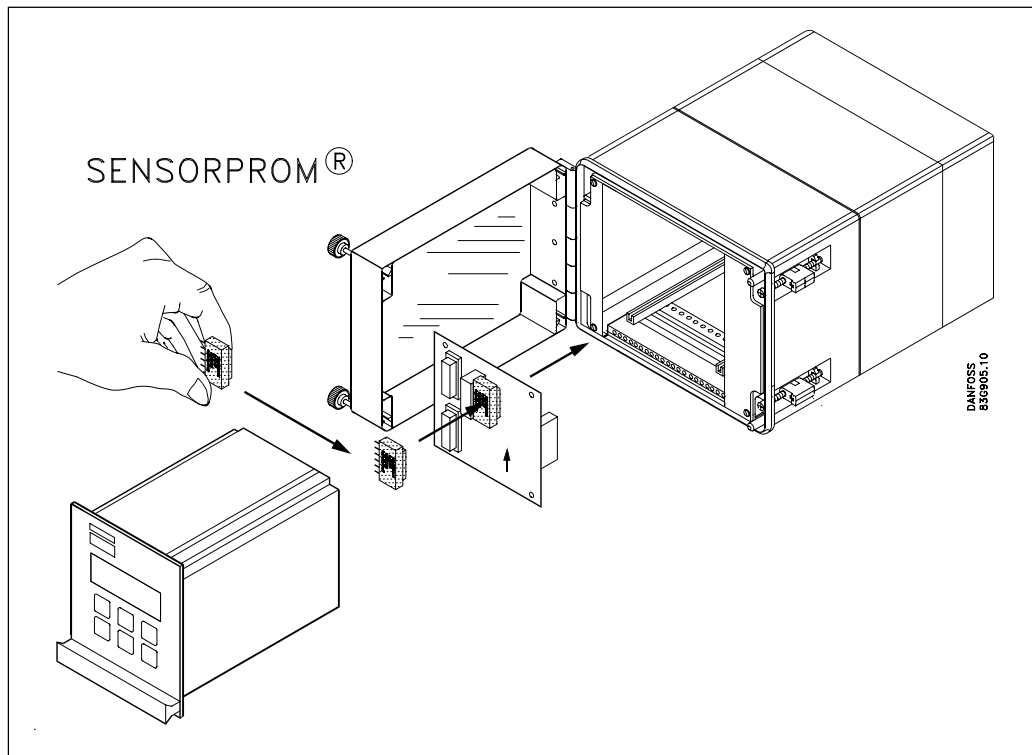

1. Mount the SENSORPROM® memory unit on the connection board as shown. The SENSORPROM® unit is supplied with the sensor in the terminal box.
2. Fit the enclosure in a cut out at the front of a panel. Fasten the four screws accessible at the front.
3. Connect the cables as shown under "Electrical connection", section 7.
4. Plug in the signal converter and close the cover.

6.2.7
Installation in the back of
a panel

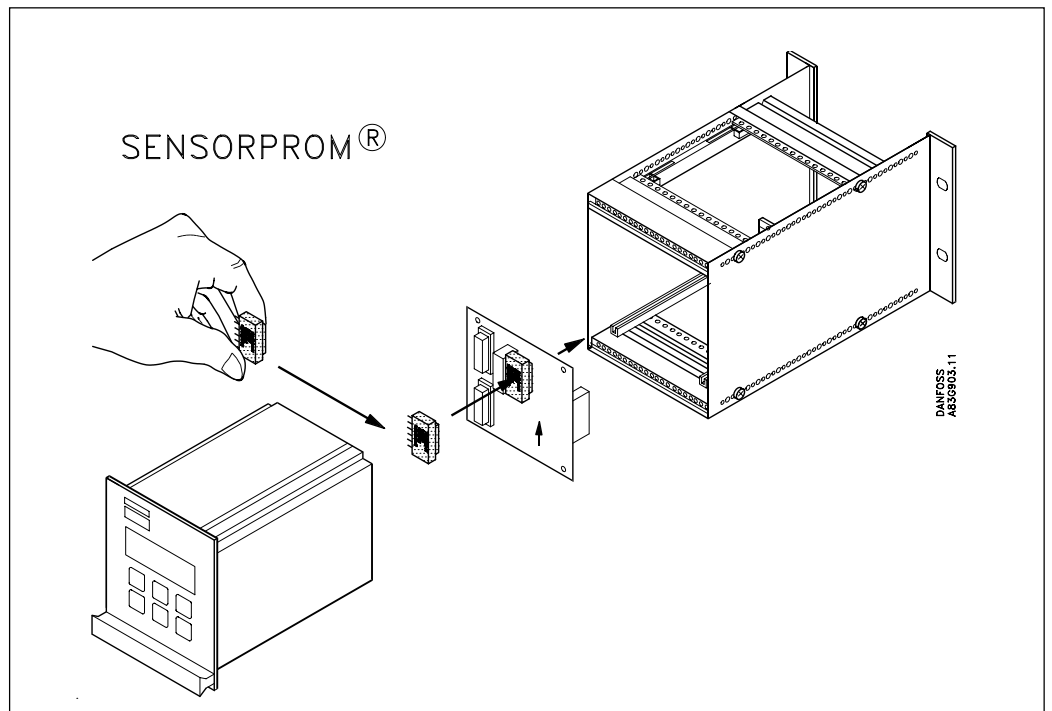

1. Mount the SENSORPROM® memory unit on the connection board as shown. The SENSORPROM® unit is supplied with the sensor in the terminal box.
2. Mount the connection board in the back of the enclosure.
3. Connect the cables as shown under "Electrical connection", section 7.
4. Mount the enclosure in the back of a panel with four screws.
5. Plug in the signal converter.

6.3
Signal converter
Safety barrier

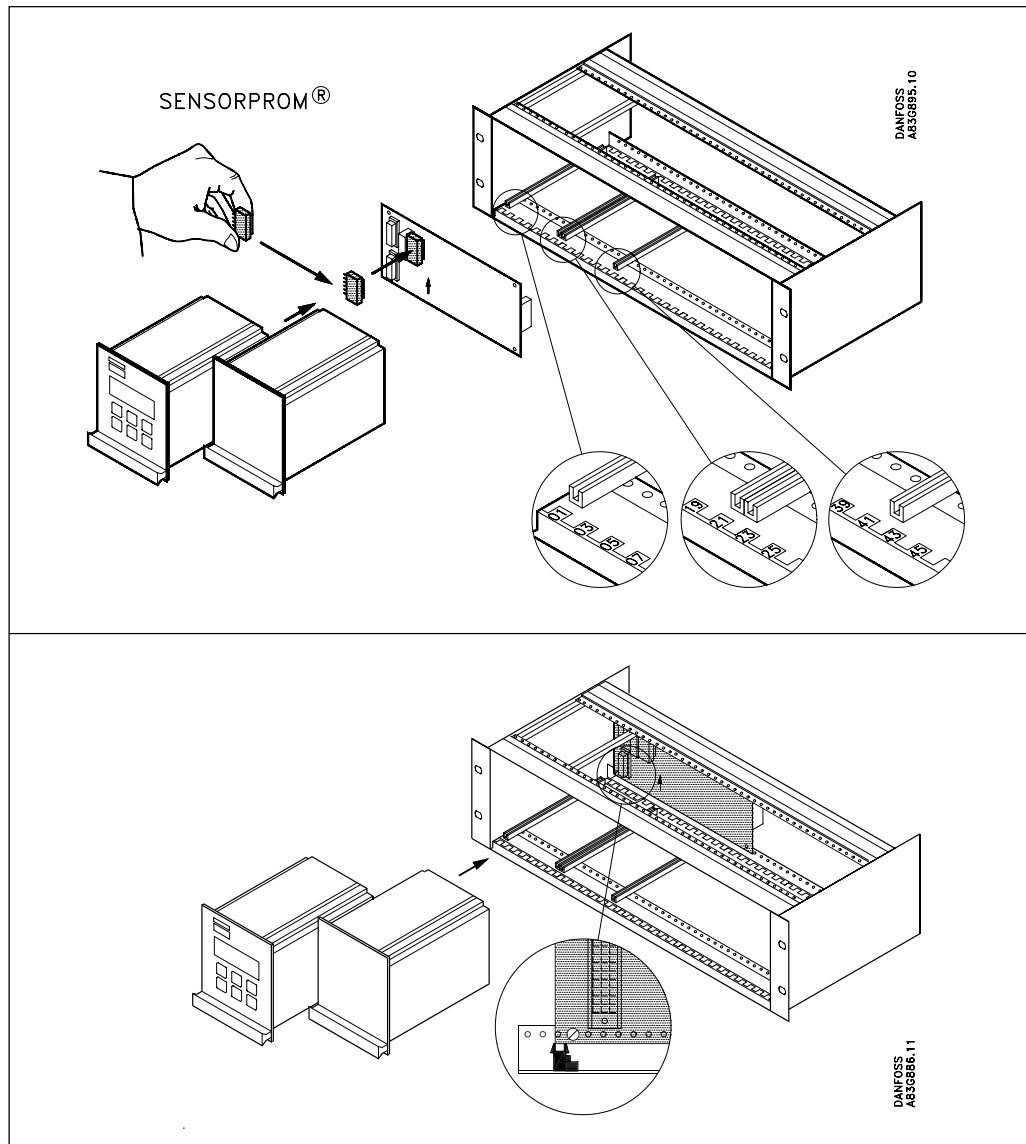

1. Fit the SENSORPROM® memory unit on the connection board supplied with the safety barrier. The SENSORPROM® unit is delivered mounted in the terminal box of the sensor. The connection board supplied with the signal converter is not used.
2. Mount the guide rails in the rack system as shown. Distance between guide rails is 20 TE. Guide rails are supplied with the rack system and not with the signal converter.
3. Mount the connection board as shown. The mounting screw must be installed just in line with the guide rails.
4. Connect the cables as shown under "Electrical connection", section 7.
5. Plug the signal converter and the safety barrier into the rack system.

6.4
Signal converter
Cleaning unit

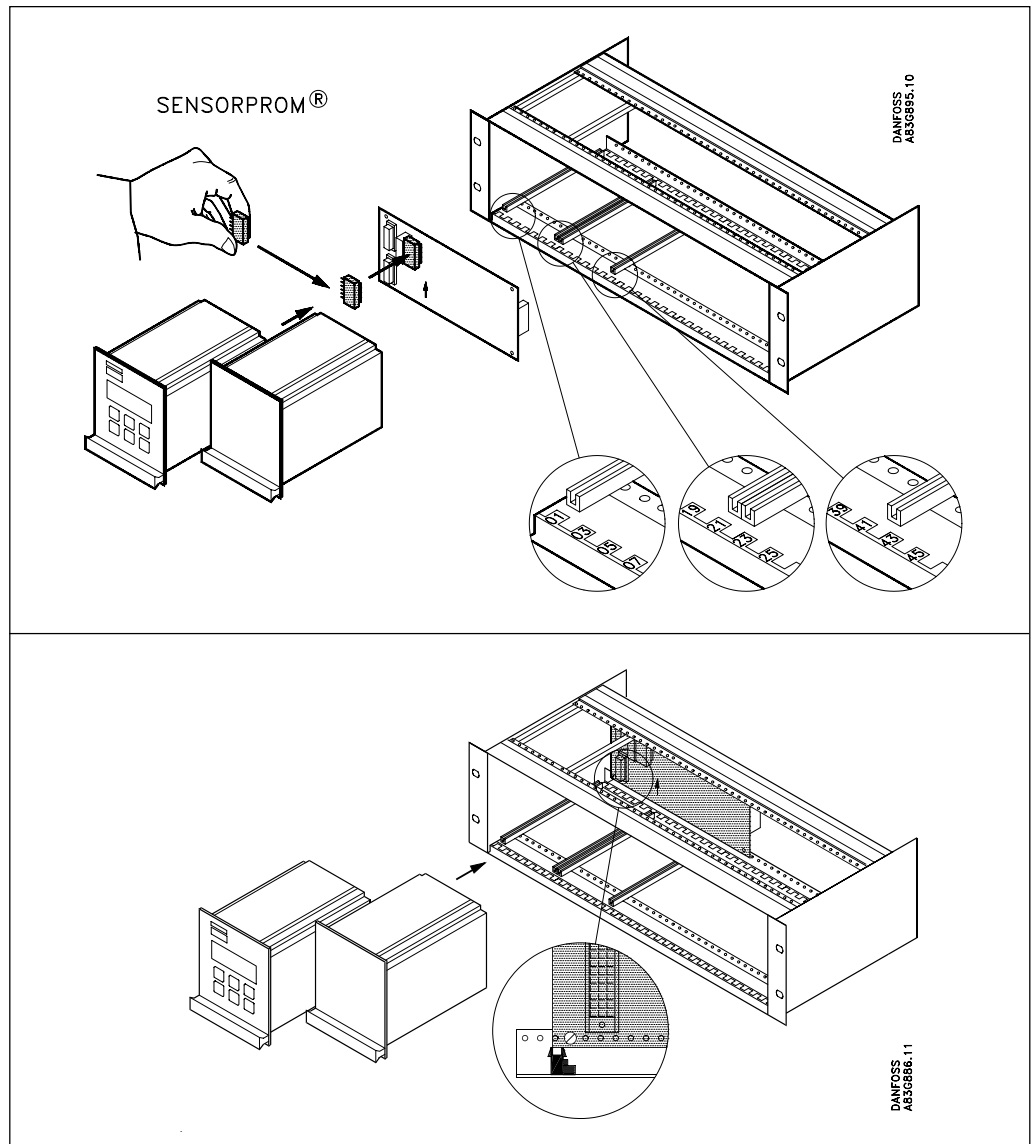

Installation of signal conv.

1. Fit the SENSORPROM® memory unit on the connection board supplied with the cleaning unit. The SENSORPROM® unit is delivered mounted in the terminal box of the sensor. The connection board supplied with the signal converter is not used.
2. Mount the guide rails in the rack system as shown. Distance between guide rails is 20 TE. Guide rails are supplied with the rack system and not with the signal converter.
3. Mount the connection board as shown. The mounting screw must be installed just in line with the guide rails.
4. Connect the cables as shown under "Electrical connection", section 7.
5. Select AC-cleaning or DC-cleaning mode at the switch located on the base of the cleaning unit.
6. Insert the cleaning unit and the signal converter in the rack system.

6.5
Signal converter
MAG 6000 CT
Sealing

The final sealing is carried out as shown:

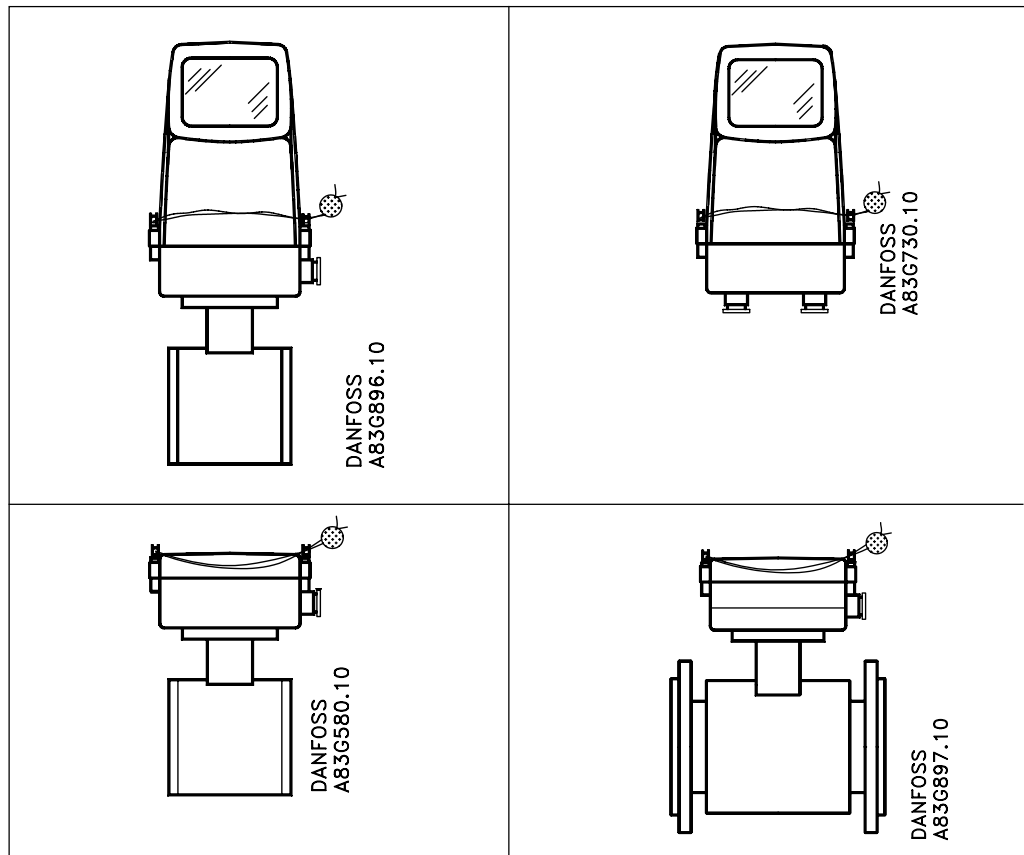

MAG 6000 CT is installed like a standard MAG 6000 except for the final sealing. Calibration sealing has been carried out at calibration.

7.1
Signal converter
MAG 5000 and MAG 6000

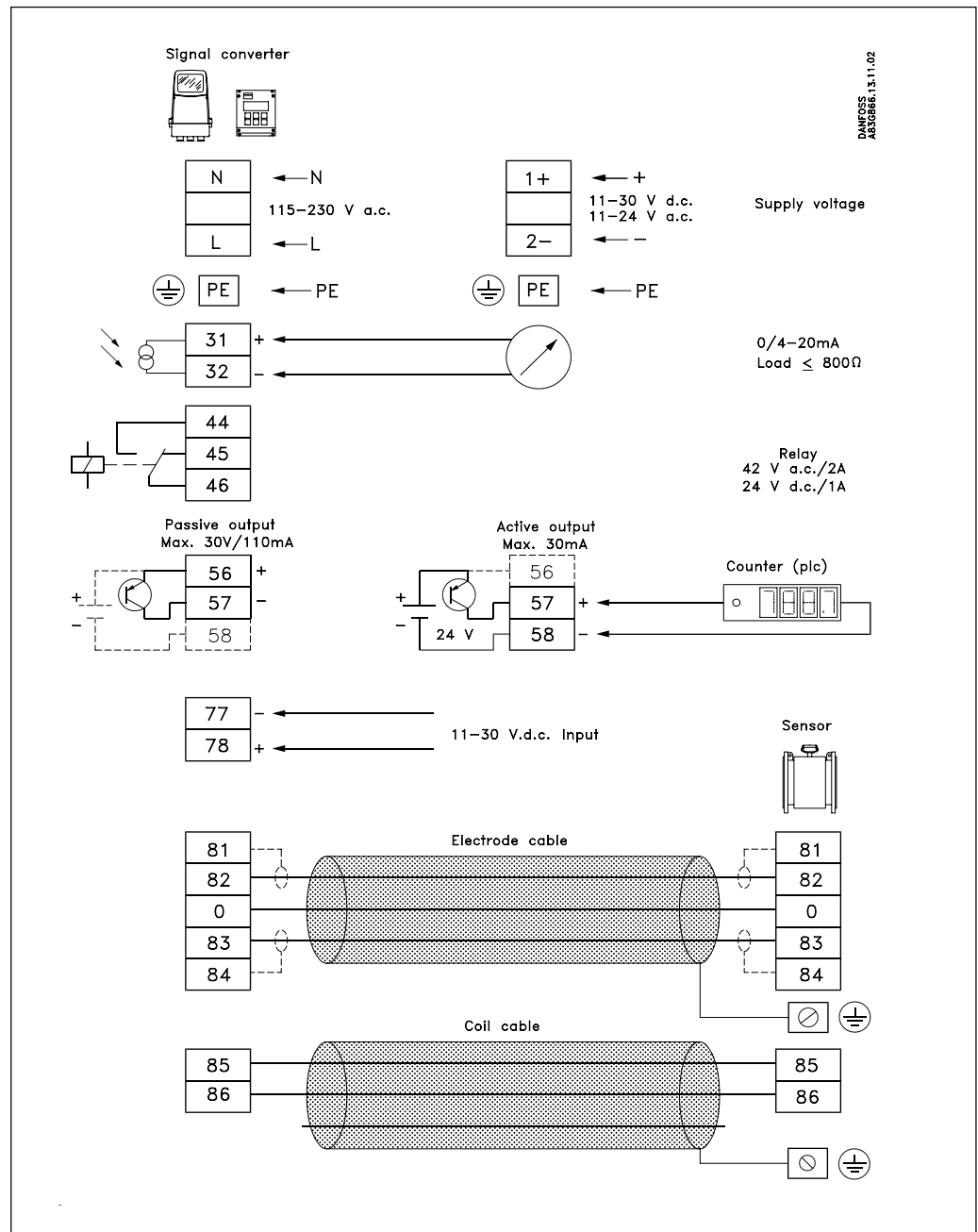

Sensor cables

- Unscreened cable ends must be as short as possible and the two cables must be kept separate. Cables must be in one length and must not be taken to a distribution box or similar terminal arrangement.
- Terminals 81 and 84 are only connected when special electrode cable with double screening is used.
- Normally the external shield is not connected to the signal converter. In environments with strong electrical noise the external screen must be earthed in both ends.

Cathodic protected piping

By compact mounting:

The signal converter must be supplied through an isolation transformer. The terminal "PE" must not be connected.

By remote mounting:

The screen must only be connected at the sensor end via a 1.5 µF capacitor. The screen must never be connected at both ends.

Digital output

- If the internal resistance of the load exceeds 10kΩ, it is recommended to connect an external 10kΩ load resistor in parallel to the load.

7.2
Signal converter with
safety barrier

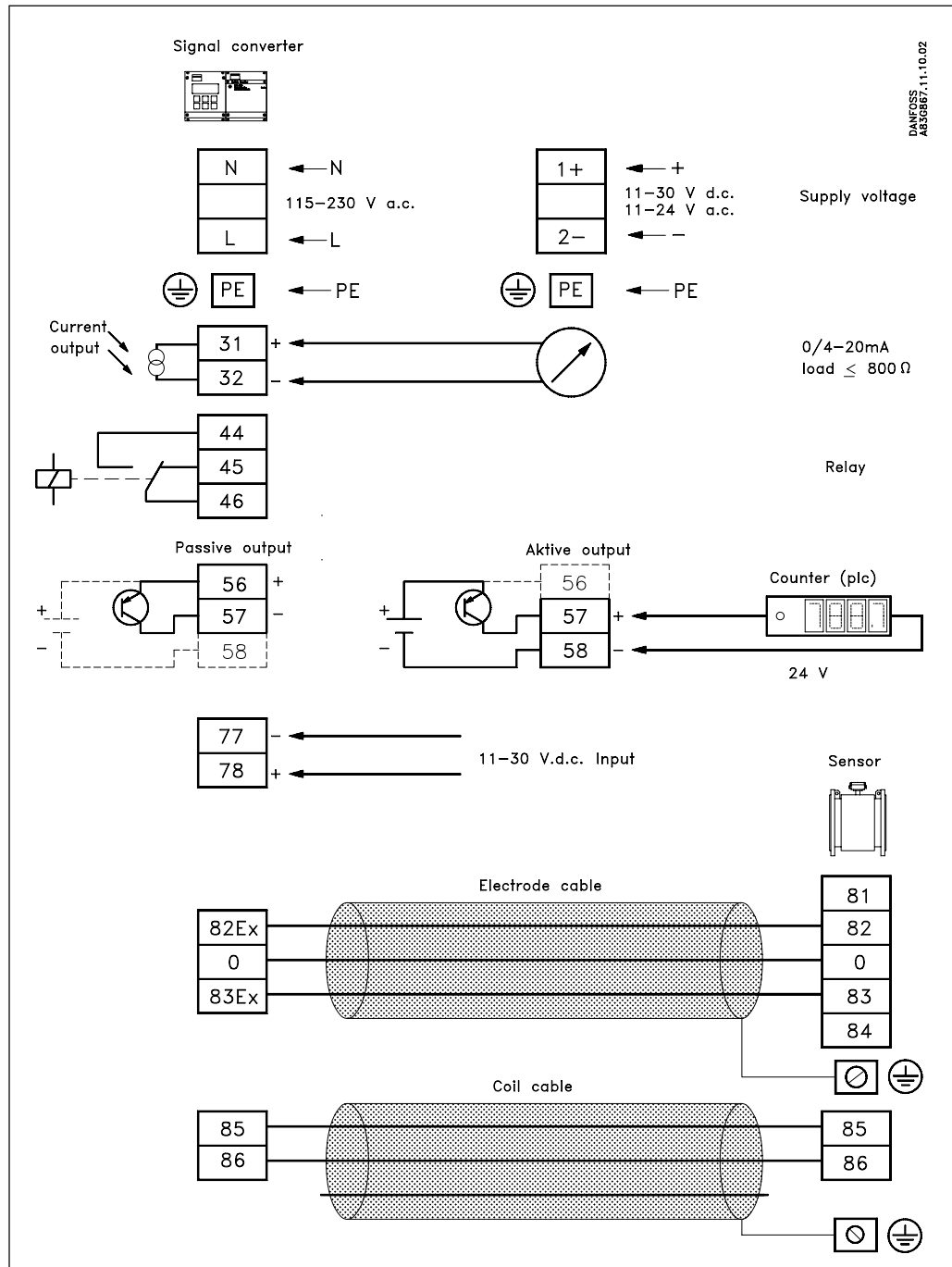

All cables and installations in hazardous areas must conform to the national code of practise.

The sensor and safety barrier must be connected to a potential equalising rail with an insulating copper wire according to national regulations. A cross section of 4 mm² (min.) must be used if not specified otherwise in national regulations.

The screen of the cables between sensor and signal converter/safety barrier must be connected at the sensor end. The screen must never be connected at both signal converter and sensor end.

Cables must be in one length and unscreened cable ends must be kept as short as possible.

7.3
Signal converter with
cleaning unit

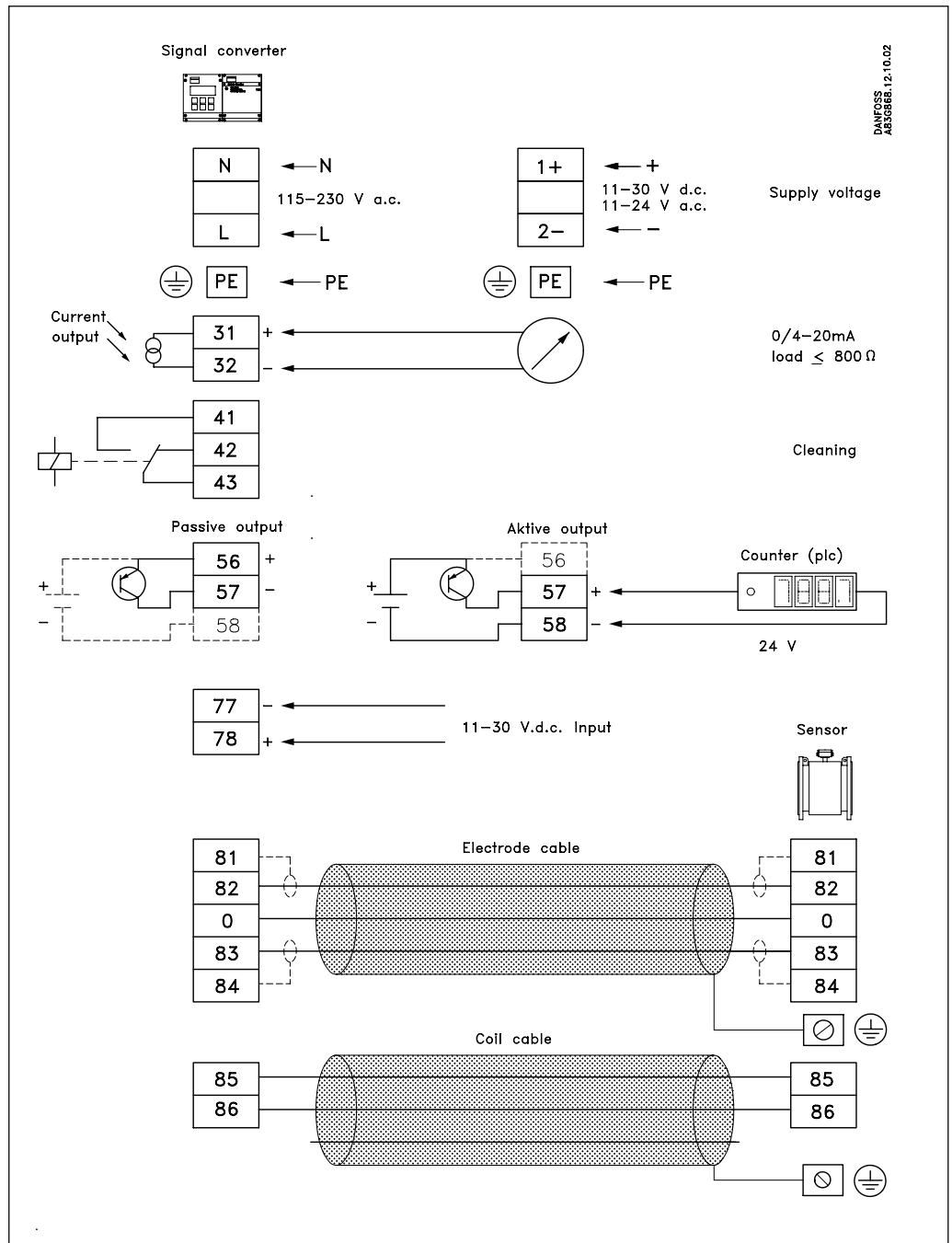

7.4
HART® communication

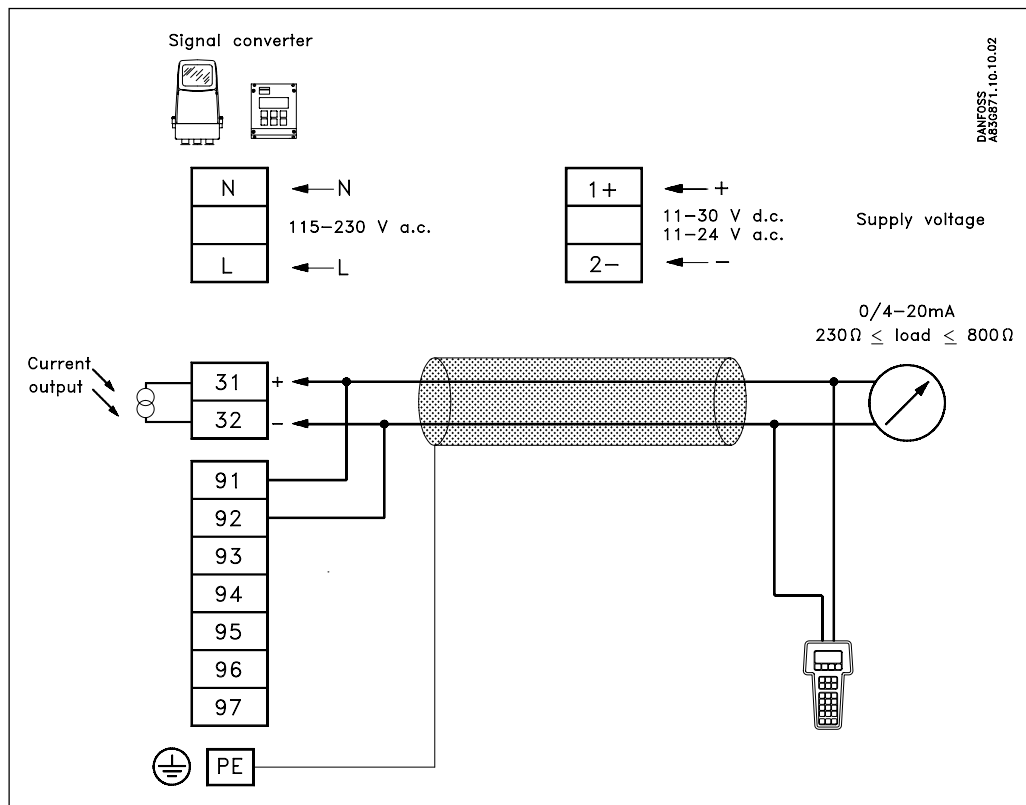



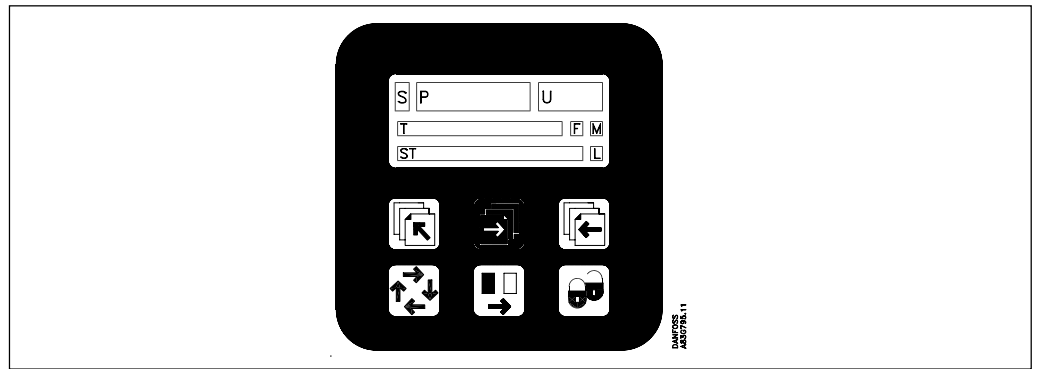



8.1 Keypad and display layout



Keypad

The keypad is used to set the flowmeter. The function of the keys are as follows:

- TOP UP KEY**  This key (hold 2 sec.) is used to switch between operator menu and setup menu. In the converter setup menu, a short press will cause a return to the previous menu.
- FORWARD KEY**  This key is used to step forward through the menus. It is the only key normally used by the operator.
- BACKWARD KEY**  This key is used to step backward through the menus.
- CHANGE KEY**  This key changes the settings or numerical values.
- SELECT KEY**  This key selects the figures to be changed.
- LOCK/UNLOCK KEY**  This key allows the operator to change settings and gives access to submenus.

Display

The display is alphanumeric and indicates flow values, flowmeter settings and error messages.

The upper line is for primary flow readings and will always show either flowrate, totalizer 1 or totalizer 2. The line is divided into 3 fields.











- S: Sign field
- P: Primary field for numerical value
- U: Unit field

The centre line is the title line (T) with individual information according to the selected operator or setup menu.





The lowest line is the subtitle line (ST) which either will add information to the title line or keep individual information independent of the title line.

F: The alarm field.  Two flashing triangles will appear by a fault condition.

M: The mode field. The symbols indicate the following.

 Communication mode	 Basic settings
 Service mode	 Output
 Operator menu	 External input
 Product identity	 Sensor characteristic
 Language mode	 Reset mode

L: The lock field. Indicates the function of the lock key.

 Ready for change	 Access to submenu
 Value locked totalizers and initialization of setting	 RESET MODE: Zero setting of

8.2 Menu build-up

The menu structure of a specific type of signal converter is shown in a menu overview map. Details of how a specific parameter is set is shown in a menu detail map for the specific parameter. A detail map is valid for each type of signal converter if not indicated otherwise. The menu structure is valid for the title and subtitle line only. The upper line is for primary readings only and will always be active with either flowrate, totalizer 1 or totalizer 2.

The menu is built up in two parts. An **operator menu** and a **setup menu**.

Operator menu

The operator menu is for daily operation. The operator menu is customised in the operator menu setup. The signal converter always starts in the operator menu no. 1. The page forward and page backward keys are used to step through the operator menus.

Setup menu

The setup menu is for commissioning and service only.

Access to the setup menu is gained by pressing the top up key for 2 seconds. The setup menu will operate in two modes:

- View mode
- Setup mode

View mode is a read only mode. The pre-selected settings can only be scanned.

Setup mode is a read and write mode. The pre-selected settings can be scanned and changed. Access to the setup mode is protected with a password. The factory set password is 1000.

Access to a submenu in the set up menu is gained by the lock key. A short press on a top up key will bring you back to the previous menu. A long press (2 sec.) on the top up key will exit the setup menu and bring you back to the operator menu no. 1.

8.2.1 Password

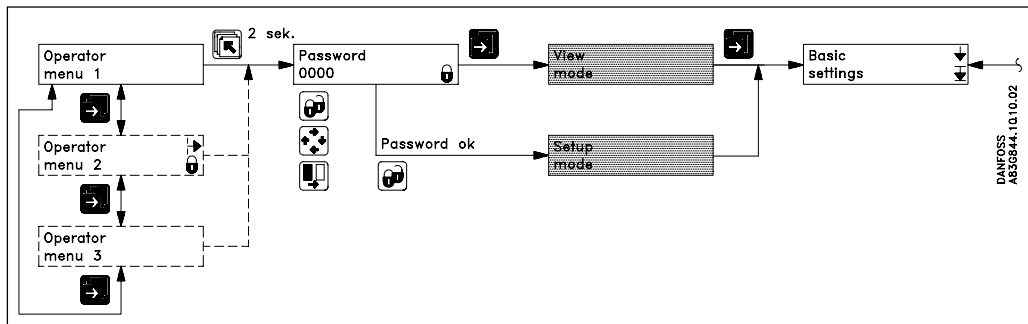

The SETUP MENU can be operated in two different modes:

- VIEW MODE** (Read only)
- CHANGE MODE** (Read and write mode)

Access to view mode is always gained by pressing the forward key when in the password menu.

Access to change mode is protected by a user code. The user code is factory set to 1000, but can be changed to any value between 1 and 9999 in the change password menu.

The factory setting of 1000 can be re-established as follows:

- Switch off power supply
- Press the TOP UP key and switch on the power supply
- Release the key after ROM and RAM test are completed

The user code is now reset to 1000.

8.3.1 MAG 5000 and MAG 6000

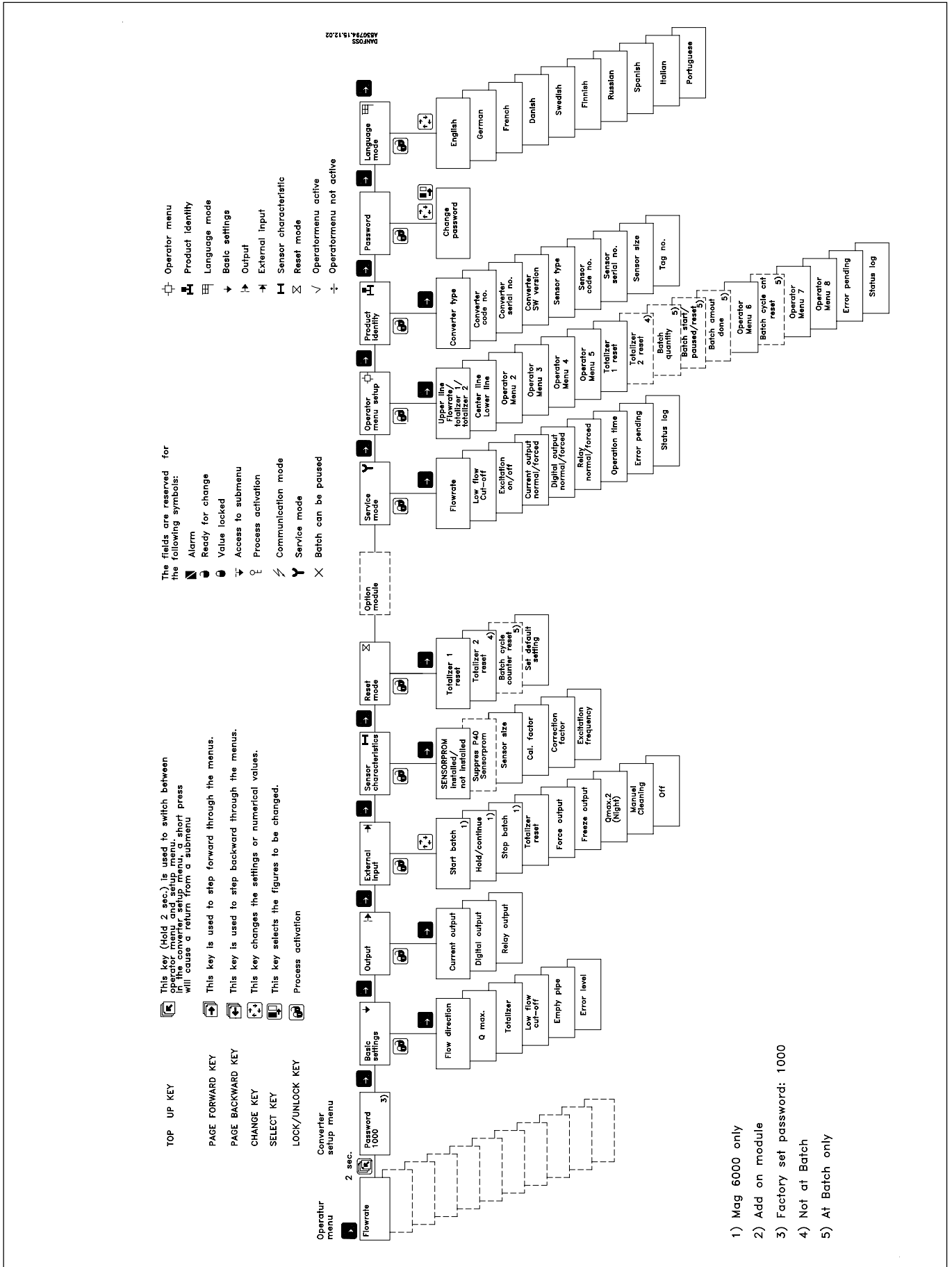

8.3.2 MAG 6000 CT

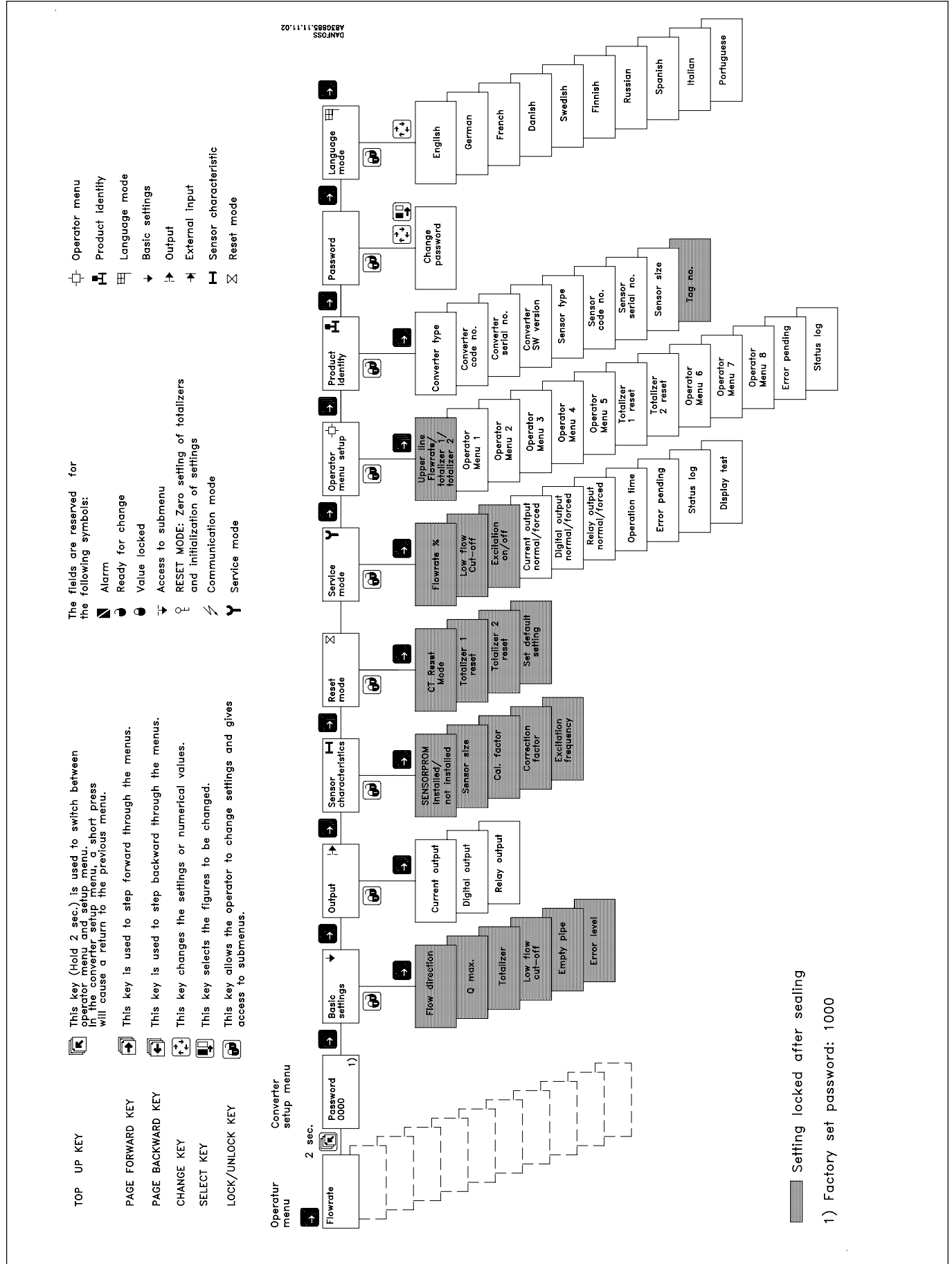

8.4.1
Basic settings

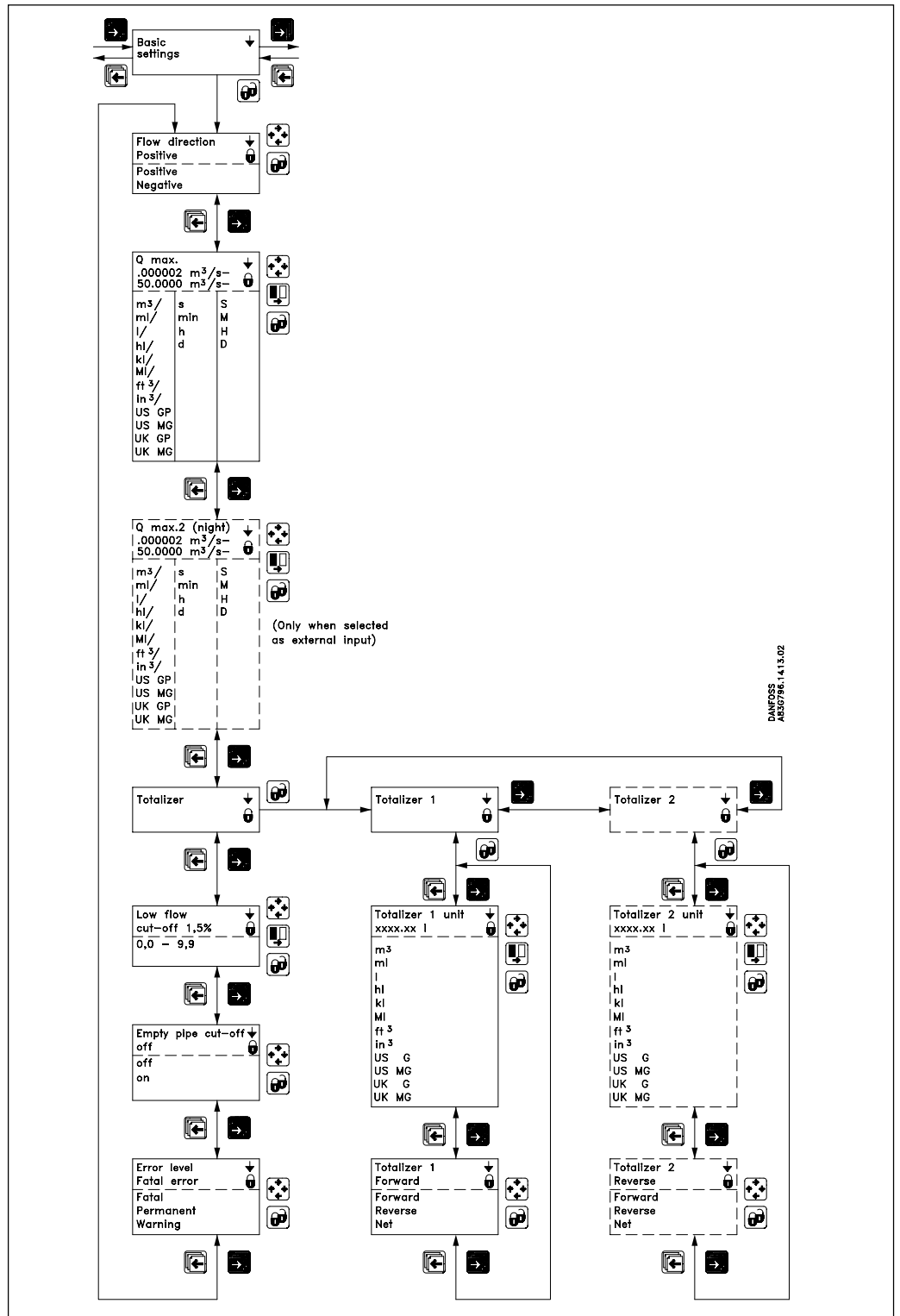

8.4.2
Outputs
Current output

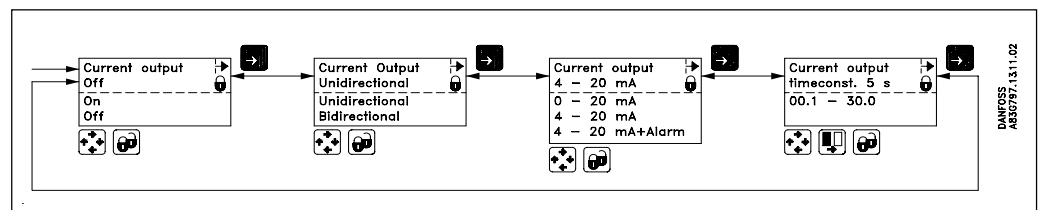

The current output must be set off when not used.

Digital and relay outputs

Error level

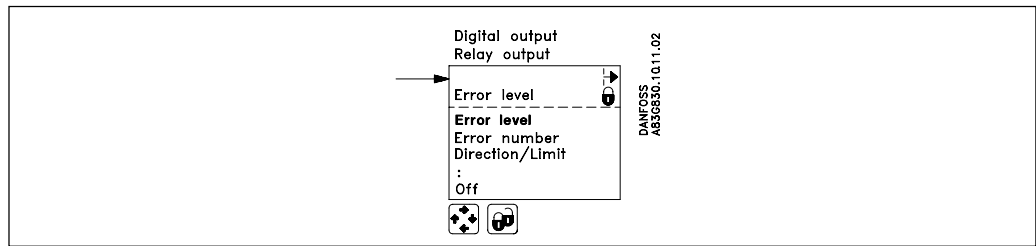

Error number

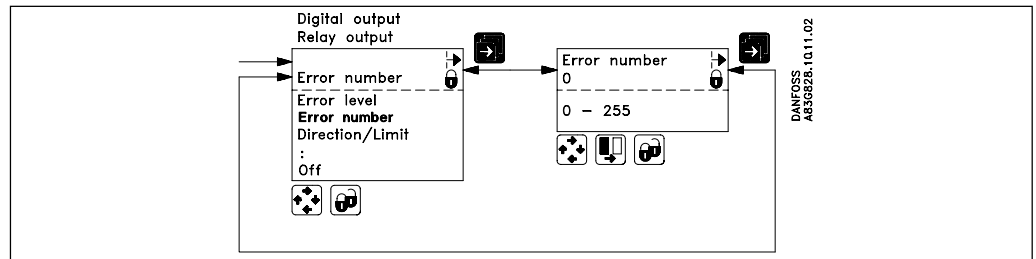

Error output is available in both digital as well as relay output.
Acceptance level is set in the basic settings.

Limit/direction

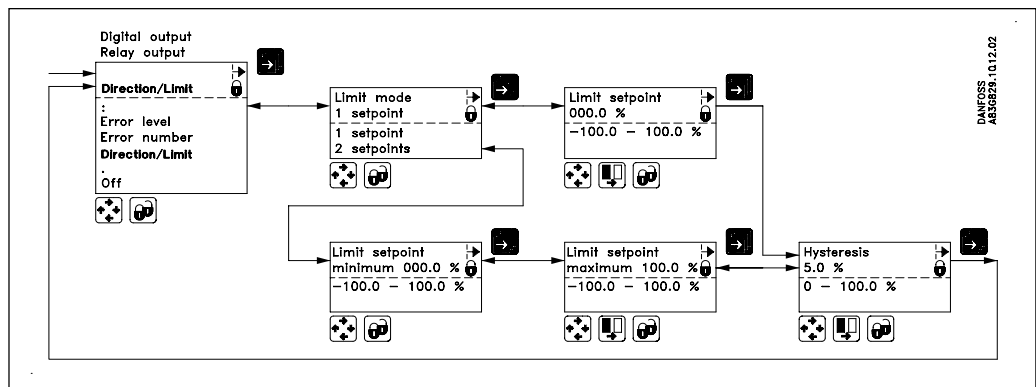

Limit switches are available for both digital as well as relay output.

Direction mode: 1 setpoint a 0% flow; hysteresis 5%.

If 2 setpoints have to activate 2 separate outputs, a single setpoint has to be selected individually for digital as well as relay outputs.

Frequency

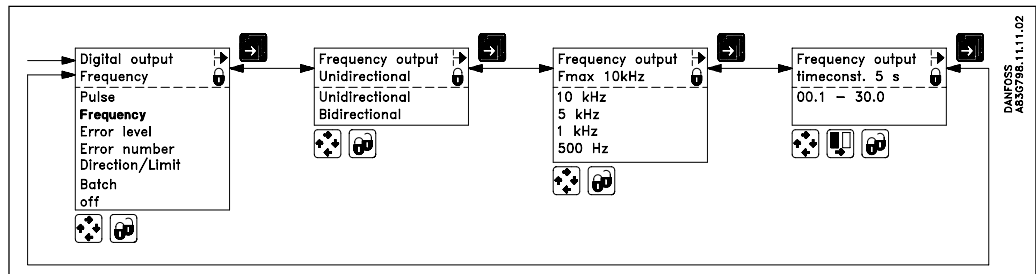

Frequency output can only be selected for the digital output.

Pulse

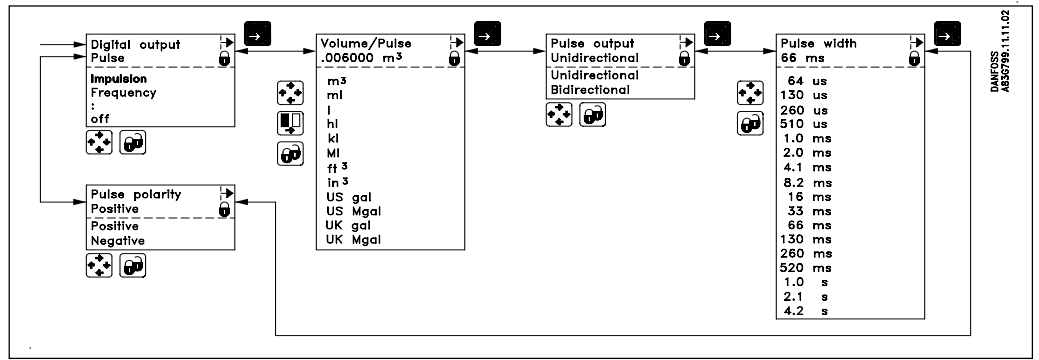

Pulse output can only be selected for the digital output.

Batch

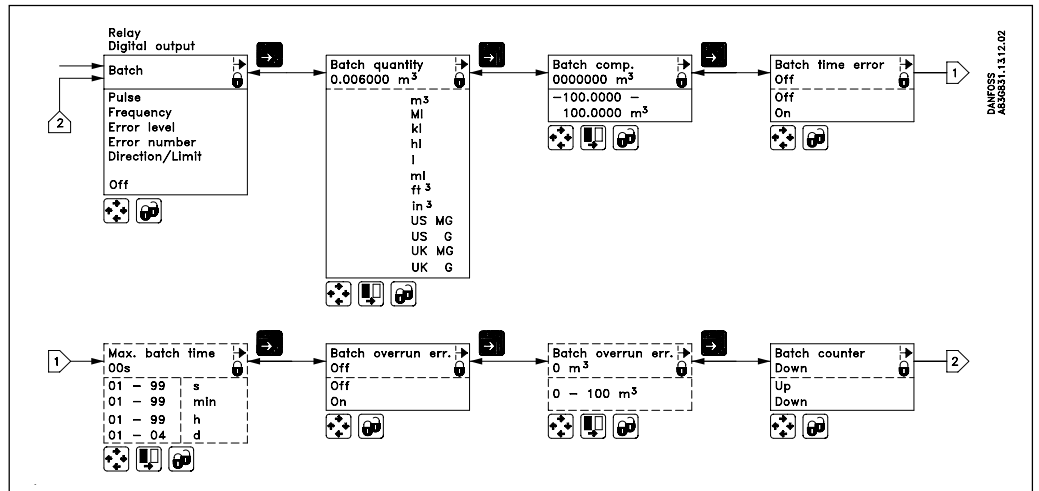

The batch function is available on MAG 6000 only.

Cleaning

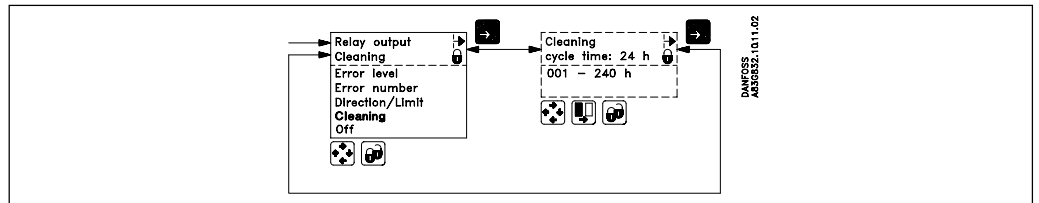

The relay output must always be used to operate the cleaning unit when a cleaning unit has been installed together with the signal converter. The relay output cannot be used for other purposes.

8.4.3

External input

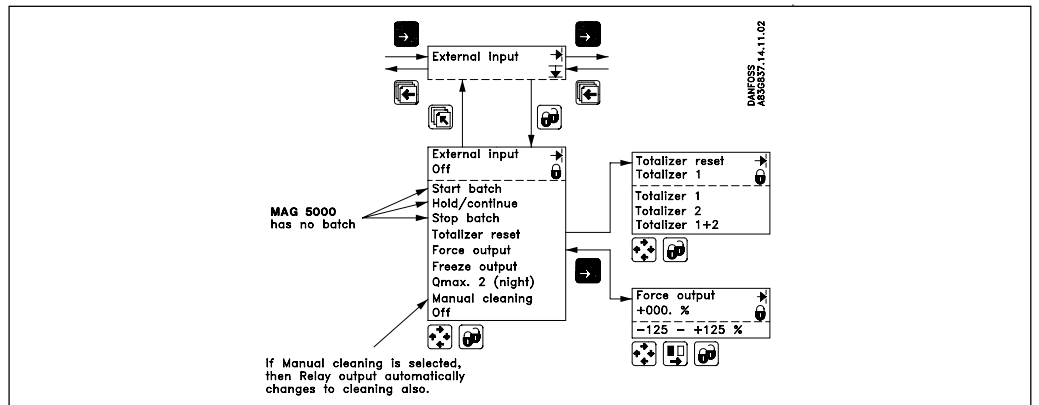

Batch control is available on MAG 6000 only.

8.4.4
Sensor characteristics

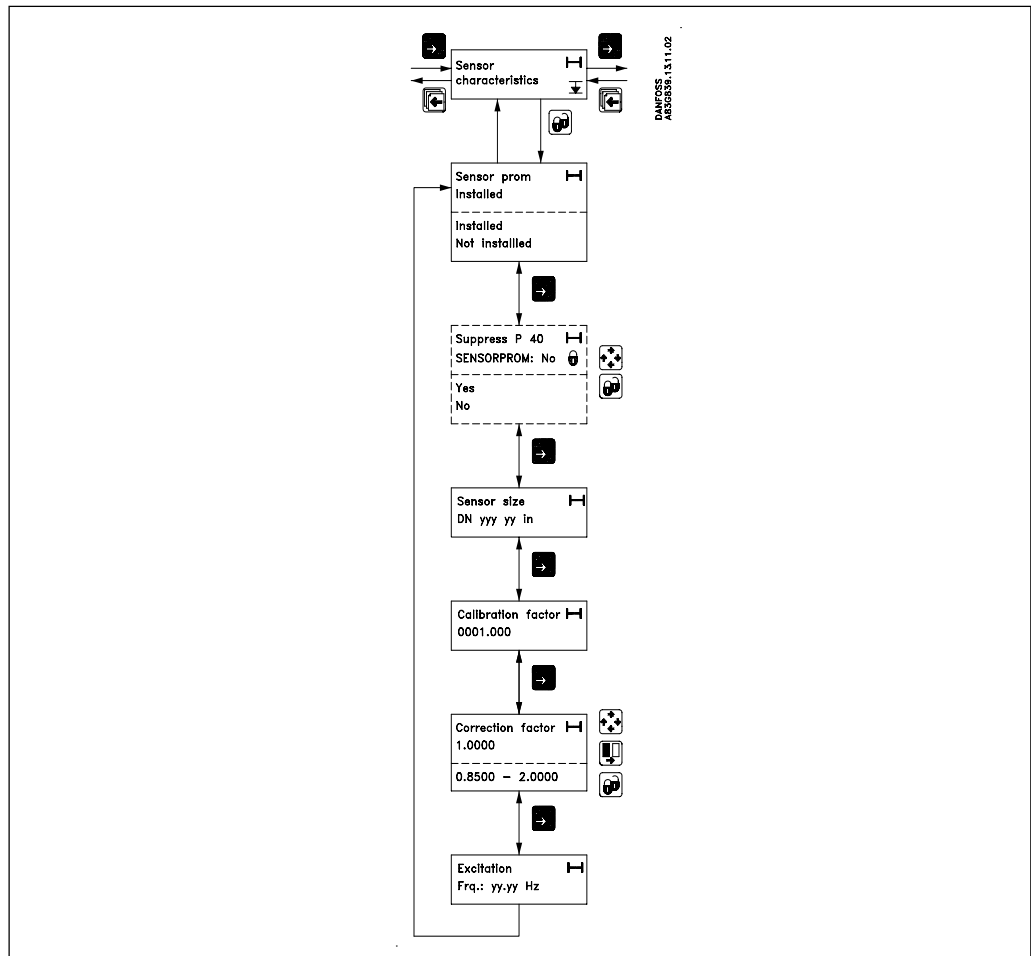

8.4.5
Reset mode

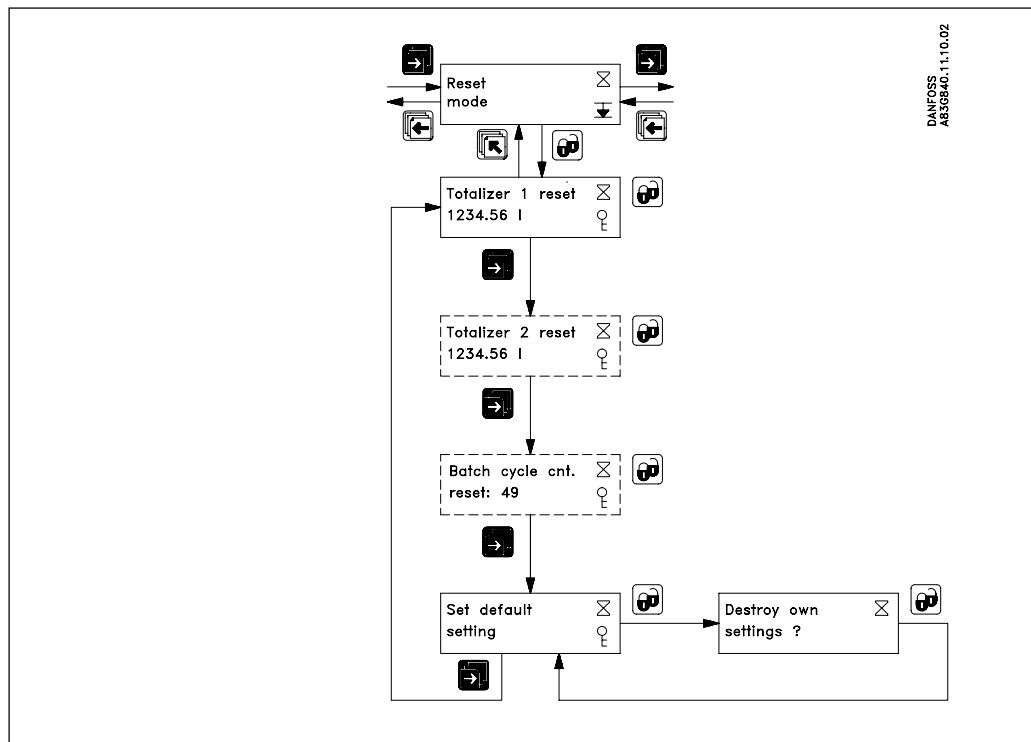

Commissioning

8.4.6 Service mode

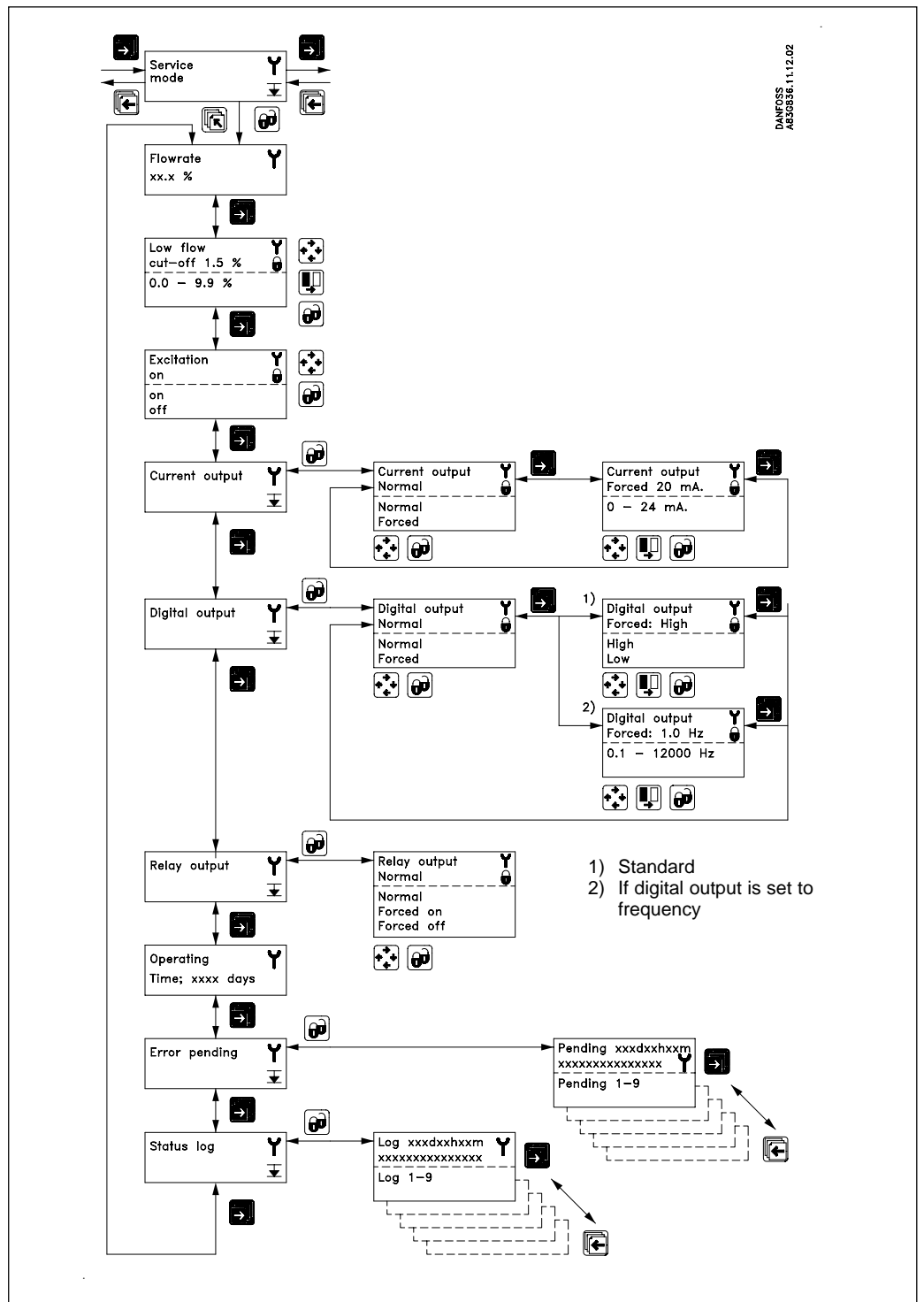

All previous settings are reinitialised when service mode is exited using the top up key.

The error system

The error system is divided into an error pending list and a status log list. Time is gained as days, min. and hours since the error has occurred.

The first 9 standing errors are stored in error pending. When an error is removed it is removed from error pending.

The last 9 errors are stored in the error log. When an error is removed it is still kept in error log. Errors in error log is kept in 180 days.

Error pending and error log are, accessible when enabled in the operator menu.

8.4.7 Operator menu setup

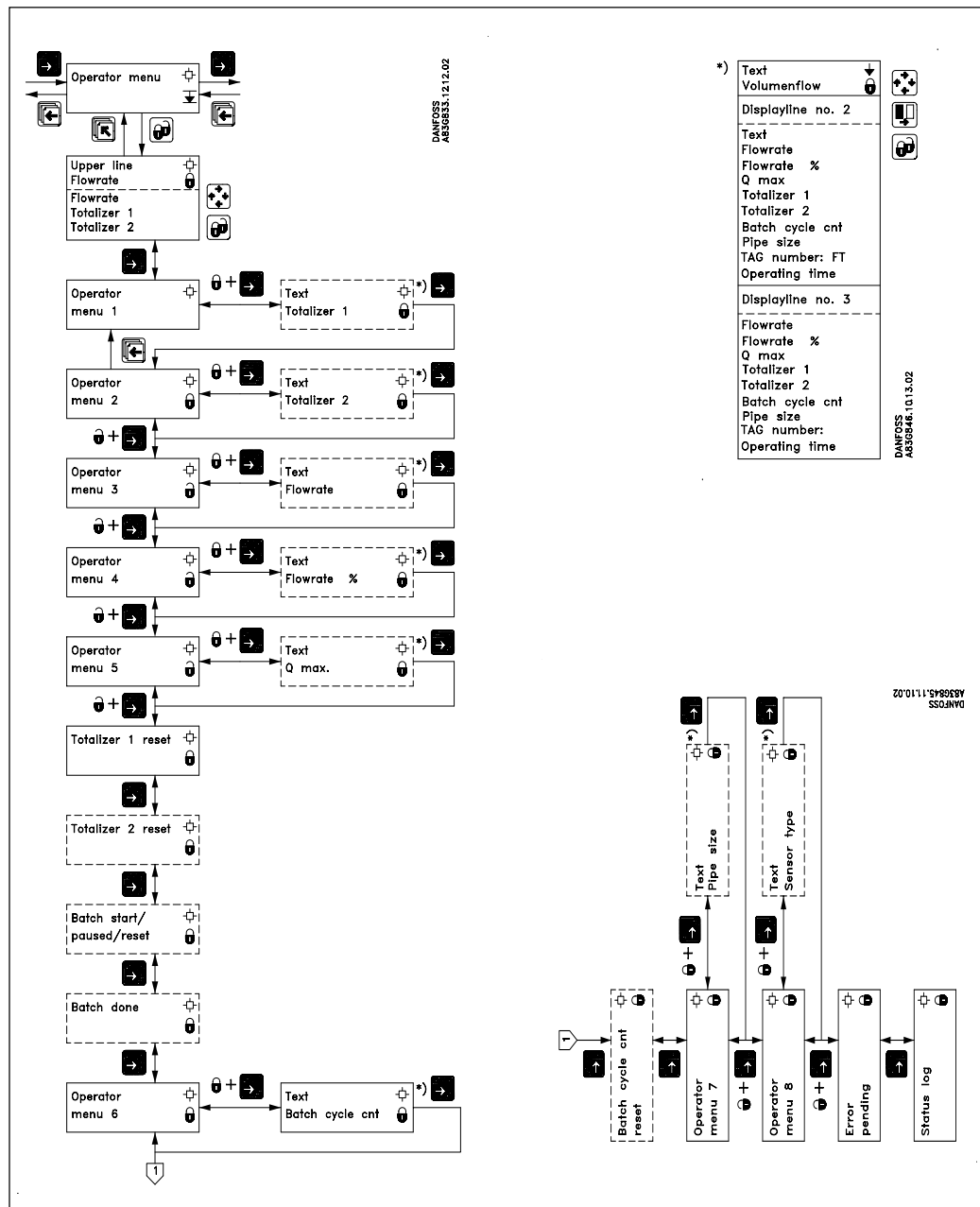

The upper line is always active and can never be deselected.

The two lower lines are for individual operator information. Information which the operator can scroll through with the forward key.

- A closed lock key in the operator menu setup, means that the menu is enabled when viewing the operator menu.
- A open lock key symbol, means that the menu is not available in the operator menu.

The middle line can either be used as a heading “Text line” for the lower line, or as a flow-reading. A flow reading can be individually selected for each menu.

The lower line may be used for an additional flow reading to the reading already available in the upper line.

8.4.8
Product identity

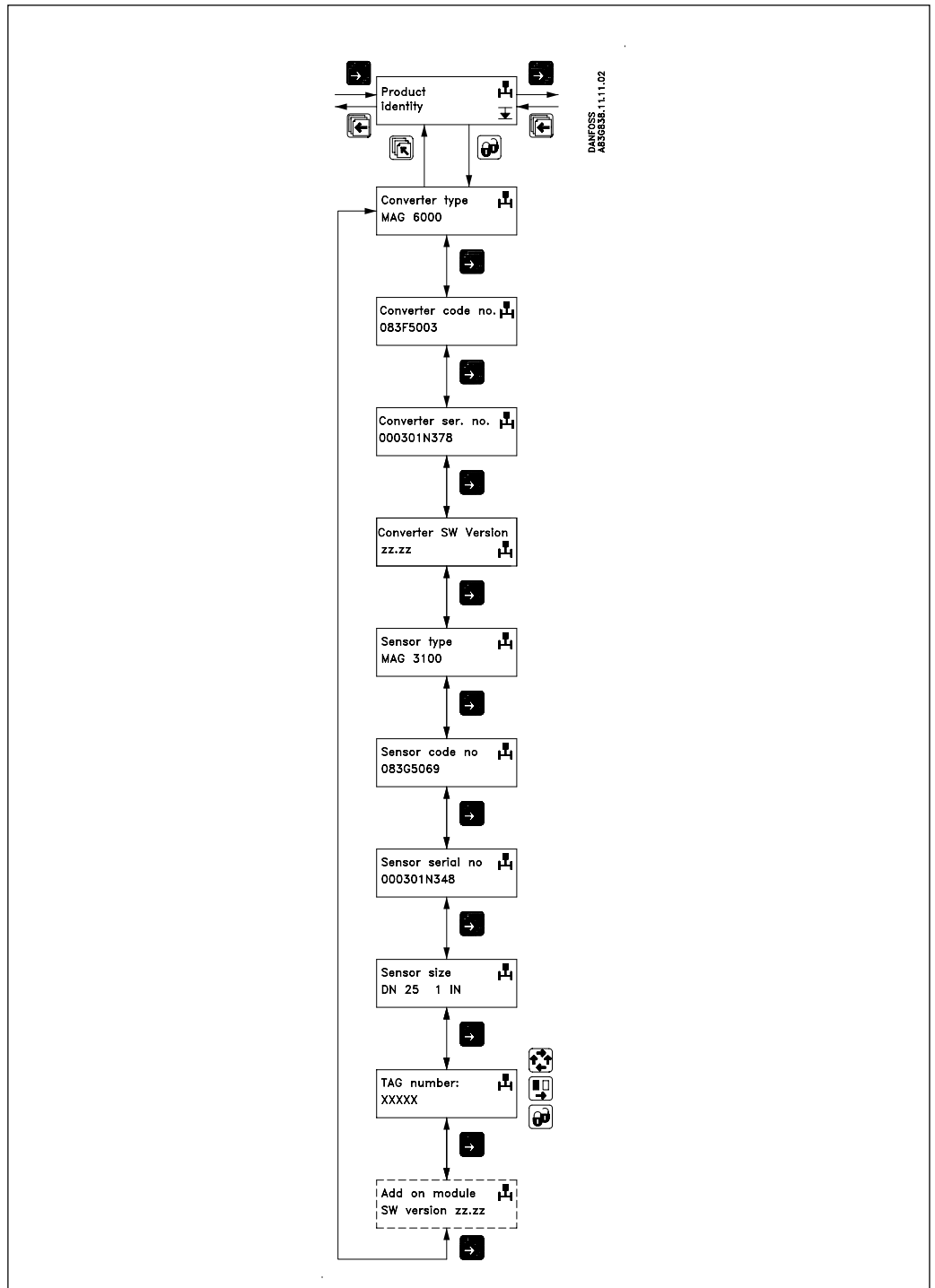

Software version of add-on module is only available if the add-on module has been installed.

8.4.9
Change password

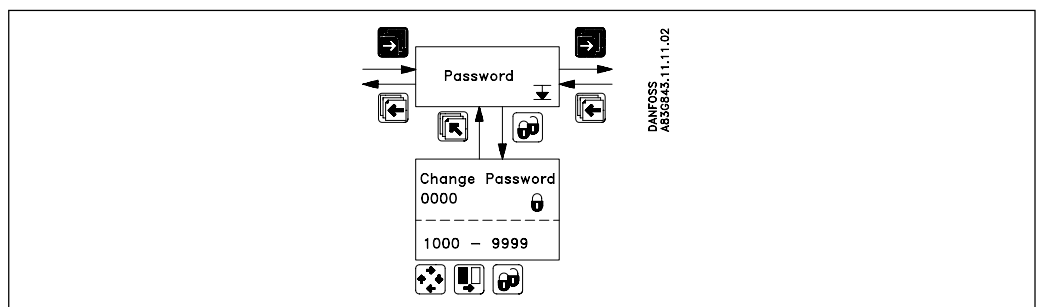

8.4.10
Language mode

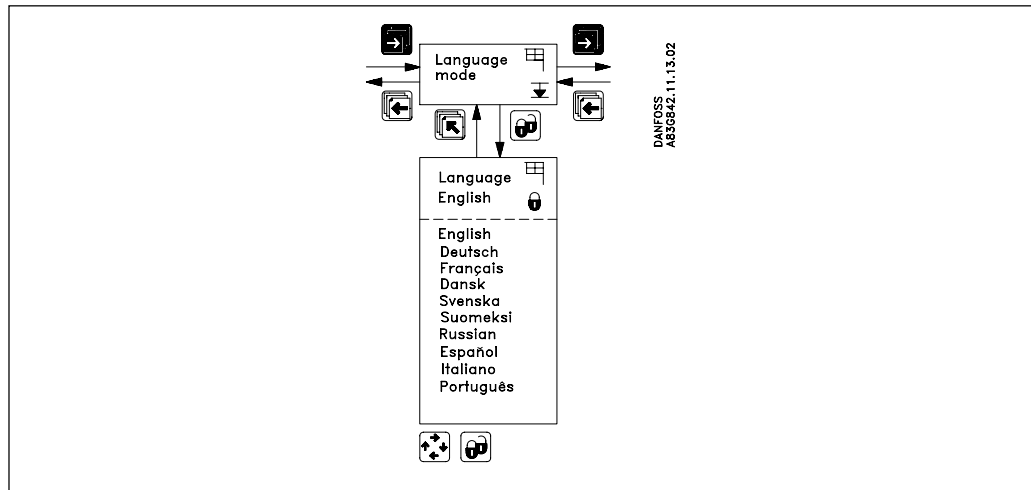

8.4.11
HART® communication
(Add-on module)

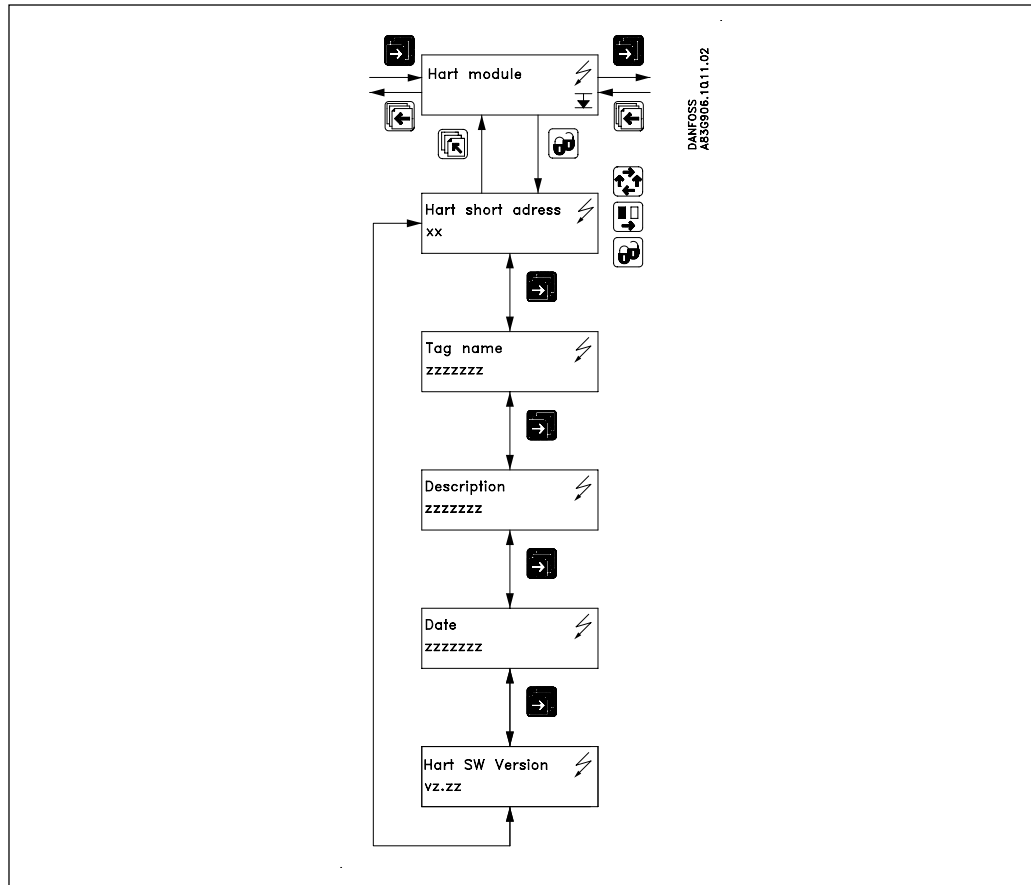

8.5.1
Flowrate

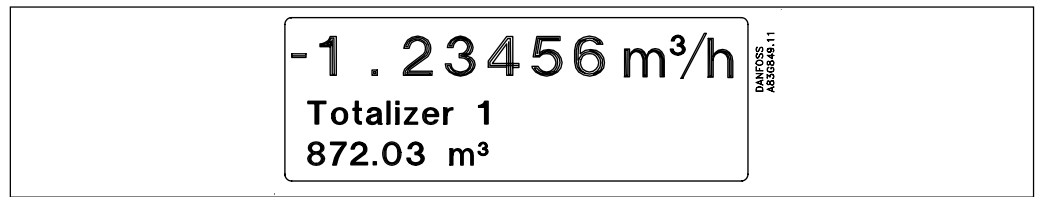

The 1st displayline will always be active and show the value enabled in the operator menu setup.

- Flowrate
- Totalizer 1
- Totalizer 2

The 2nd and 3th display lines are individually set in the operator menu. The page forward key steps through the enabled settings.

- Flowrate
- Totalizer
- Totalizer reset
- Batch control
- Batch cycle counter
- Batch cycle counter reset
- Pipe size
- Sensor type
- Pending errors
- Status log
- Tag no.

8.5.2
Totalizer

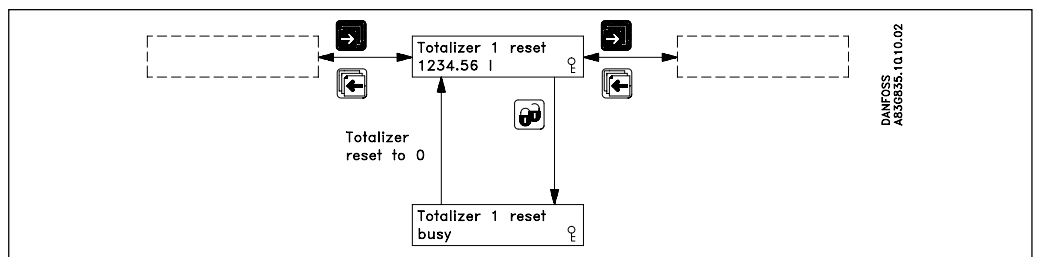

A totalizer is reset by pressing the lock key when the corresponding totalizer reset window is open.

8.5.3
Batch

Only available on
MAG 6000

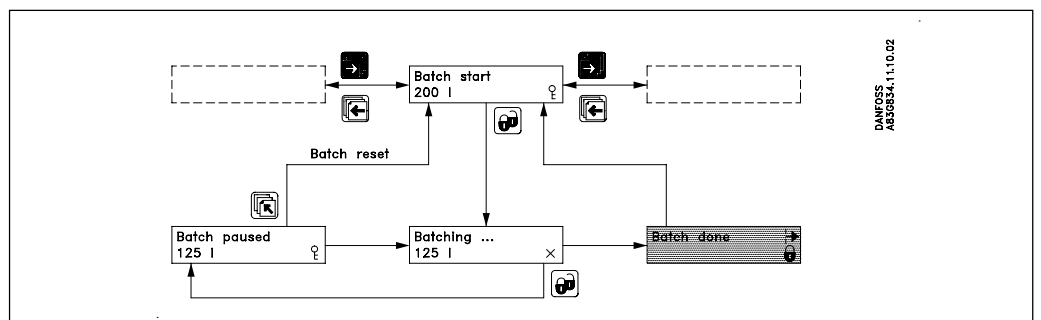

A batch can be started, paused or stopped from the operator menu, in addition to the externally operated batch control. The batch is controlled using the lock and the top up keys.

The lock key:

- Starts the batch
- Holds the batch (pause) when pressed during batching
- Restarts the batch to continue when pressed during a pause.

The top up key resets a batch completely during a pause.

Batch cycle counter

The accumulated number of performed batches can be viewed when enabled in the operator menu setup.

Batch cycle counter reset

The batch cycle counter is reset by pressing the lock key in the "batch cycle cnt reset" menu.

8.6.1
Settings available

The signal converter is delivered with factory settings ready to measure the actual flow.

Parameter	Factory setting	Settings available
Password		
Default value	0000	
Password	1000	1000 - 9999
Basic settings		
Flow direction	Positive	Positive, negative
Q _{max.}	Dim. dependent	Dim. dependent
- Volume units	Dim. dependent	m ³ , ml, l, kl, hl, Ml, ft ³ , in ³ , USG, USMG, UKG, UKMG
- Time units	Dim. dependent	Sec., min., hour, day
Totalizer 1	Forward	Forward, reverse, net
- Totalizer 1 units	Dim. dependent	m ³ , ml, l, kl, hl, Ml, ft ³ , in ³ , USG, USMG, UKG, UKMG
Totalizer 2	Reverse	Forward, reverse, net
- Totalizer 2 units	Dim. dependent	m ³ , ml, l, kl, hl, Ml, ft ³ , in ³ , USG, USMG, UKG, UKMG
Low flow cut off	1.5 %	0 - 9.9 %
Empty pipe	Off	Off, on
Error level	Warning	Fatal, permanent, warning
Output		
Current output	Off	On/off, uni-/bidirectional, 0/4 - 20 mA
- Time constant	5 s	0.1 - 30 s
Digital output	Pulse	Error, direction/limit, batch ¹⁾ , frequency, pulse, error no., off
Relay output	Error	Error, direction/limit, cleaning, error no., off
Direction/limit switch	Off	1 setpoint/2 setpoints, - 100 - 100%
- Hysteresis	5%	0.0 - 100%
Batch ¹⁾	Off	
- Batch quantity	0	1 ml - 100.000 m ³
- Batch compensation	0	-100 - 100 m ³
- Batch counter	Down	Up/down
Frequency	Off	500 Hz, 1 kHz, 5 kHz, 10 kHz
- Time constant	5 s	0.1 - 30 s
Pulse	On	
- Pulse polarity	Positive	Positive/negative
- Pulse width	66 ms	64 μs, 130 μs, 260 μs, 510 μs, 1.0 ms, 2.0 ms, 4.1 ms, 8.2 ms, 16 ms, 33 ms, 66 ms, 130 ms, 260 ms, 520 ms, 1.0 s, 2.1 s, 4.2 s.
- Volume/pulse	Dim. dependent	0 - 100.00 m ³
Electrode cleaning	Off	Off/cleaning
- Cleaning cycle time	24 h	1 - 240 h
External input		
External input	Off	Batch, reset totalizer, freeze output, forced output, off
- Batch		Start, hold/continue, stop
Sensor characteristics		
Correction factor	1	0.85 - 2.00
Language		
	English	English, German, French, Danish, Swedish, Finish, Spanish, Russian, Italian, Portugese
Operator menu		
Primary field	Flowrate	Flowrate, Totalizer 1, Totalizer 2
Title/subtitle line	Flowrate	Flowrate, Flowrate %, Q _{max.} , Totalizer 1, Totalizer 2, Totalizer 1 reset, Totalizer 2 reset, Batch start/paused/stop, Batch cycle counter, Batch cycle counter reset, Sensor size, Sensor type, Error pending, Status log, Tag no.

¹⁾ Batch is available on MAG 6000 only

**8.6.2
Dimension-dependent
factory settings
MAG 5000 and MAG 6000**

DN		Q _{max.}				Volume/ pulse	Pulse unit	Totalizer unit
mm	[inches]	fac.set.	min.	max.	unit			
6	5/16	300	25.5	1017	l/h	1		
10	3/8	900	70.7	2827	l/h	1		
15	1/2	2000	159.1	6361	l/h	1		
25	1	5000	442.0	17671	l/h	10		
40	1 1/2	12	1.2	45	m ³ /h	10		
50	2	20	1.8	70	m ³ /h	10		
65	2 1/2	30	3.0	119	m ³ /h	100		
80	3	50	4.6	180	m ³ /h	100		
100	4	120	7.1	282	m ³ /h	100		
125	5	180	11.1	441	m ³ /h	100		m ³
150	6	250	16.0	636	m ³ /h	100		m ³
200	8	400	28.3	1130	m ³ /h	1	m ³	m ³
250	10	700	44.2	1767	m ³ /h	1	m ³	m ³
300	12	1000	63.7	2544	m ³ /h	1	m ³	m ³
350	14	1200	86.6	3463	m ³ /h	1	m ³	m ³
400	16	1800	113.1	4523	m ³ /h	1	m ³	m ³
450	18	2000	143.2	5725	m ³ /h	1	m ³	m ³
500	20	3000	176.8	7068	m ³ /h	1	m ³	m ³
600	24	4000	254.5	10178	m ³ /h	10	m ³	m ³
700	28	5000	346.4	13854	m ³ /h	10	m ³	m ³
750	30	6000	397.7	15904	m ³ /h	10	m ³	m ³
800	32	7000	452.4	18095	m ³ /h	10	m ³	m ³
900	36	9000	573.0	22902	m ³ /h	10	m ³	m ³
1000	40	12000	707.0	28274	m ³ /h	10	m ³	m ³ × 10
1100	44	14000	855.3	34211	m ³ /h	10	m ³	m ³ × 10
1200	48	15000	1018.0	40715	m ³ /h	10	m ³	m ³ × 10
1400	56	25000	1385.5	55417	m ³ /h	10	m ³	m ³ × 10
1500	60	30000	1590.5	63617	m ³ /h	10	m ³	m ³ × 10
1600	64	35000	1809.6	72382	m ³ /h	10	m ³	m ³ × 10
1800	72	40000	2290.3	91608	m ³ /h	10	m ³	m ³ × 10
2000	80	45000	2827.5	113097	m ³ /h	10	m ³	m ³ × 10

8.7.1 Error handling

Error system

The converter system is equipped with an error and status log system with 4 groups of information.

- Information without a functional error involved
- Warnings which may cause malfunction in the application. The cause of the error may disappear on its own
- Permanent errors which may cause malfunction in the application. The error requires an operator
- Fatal error which is essential for the operation of the flowmeter

2 menus are available in service and operator menus for registration of information and errors

- Error pending
- Status log

Error pending

The first 9 standing errors are stored in “error pending”. When an error is removed it is removed from “error pending”.

The acceptance level for “error pending” can be individual configured to a particular application. The acceptance level is set in the “basic setting” in the converter setup menu.

Acceptance levels

- Fatal error: Fatal errors are registered as errors
- Permanent errors: Permanent and fatal errors are registered as errors
- Warning (Default value): Warnings, permanent and fatal errors are registered as errors

The error information is displayed in the title and subtitle line. The title line will show the time since occurrence of error. The subtitle line will flash between an error text and a remedy text. The error text will indicate type of error (I, W, P or F), error no. and error text. The remedy text will inform the operator of the action to take to remove the error.

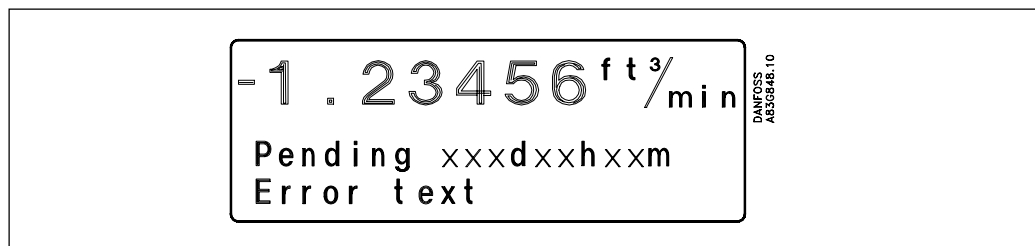

Status Log

Like “error pending” except that information, warnings, permanent and fatal errors are always stored in the “status log”. The “status log” stores the last 9 messages received/registered during the last 180 days.

Alarm field

The alarm field on the display will always flash with an error pending.

Error output

The digital and relay output can individually be activated error by an error (Error level). The relay output is default selected to error level. An output can also be selected to activate on a single error number.

The alarm field, error output and error pending will always operate together.

The analog output will turn to a 1 mA level when in the 4-20 mA mode.

Operator menu

Error pending and status log are as default enabled in the operator menu.

8.7.2
List of error numbers

Error No.	Error text Remedy text	#Comment	Outputs status	Input status
1	I1 - Power on OK	Power on has happened	Active	Active
2	I2 - Add-on Module Applied	A new module has been applied to the system	Active	Active
3	I3 - Add-on Module Install	An add-on module is defect or has been removed. This can be an internal add-on module	Active	Active
4	I4 - Param. corrected OK	A less vital parameter in the converter has been replaced by its default value	Active	Active
20	W20 - Totalizer 1 Reset manually	During initialisation the check of the saved totalizer value has failed. It is not possible to rely on the saved totalizer value any more. The totalizer value must be reset manually in order to rely on future readings	Active	Active
20	W20 - Totalizer 2 Reset manually	During initialisation the check of the saved totalizer value has failed. It is not possible to rely on the saved totalizer value any more. The totalizer value must be reset manually in order to rely on future readings	Active	Active
21	W21 - Pulse overflow Adj. pulse settings	Actual flow is too big compared with pulse width and volumen/pulse	Reduced pulse with	Active
22	W22 - Batch timeout Check installation	Duration of Batching has exceeded a predefined max. time	Batch output on zero	Active
23	W23 - Batch overrun Check installation	Batch volume has exceeded a predefined maximum overrun volume	Batch output on zero	Active
24	W24 - Batch neg. flow Check flow direction	Negative flow direction during batch	Active	Active
30	W30 - Overflow Adj. Q _{max.}	Flow is above Q _{max.} settings	Max. 120 %	Active
31	W31 - Empty pipe	Pipe is empty	Zero	Active
40	P40 - SENSORPROM® Insert/change	SENSORPROM® unit not installed	Active	Active
41	P41 - Parameter range Switch off and on	A parameter is out of range. The parameter could not be replaced by its default value. The error will disappear at the next power-on	Active	Active
42	P42 - Current output Check cables	Current loop is disconnected or the loop resistance is too big	Active	Active
43	P43 - Internal error Switch off and on	Too many errors occurred at the same time Some errors are not detected correctly	Active	Active
60	F60 - CAN comm. error Converter/AOM	CAN bus communication error. An add-on module, the display module or the converter is defect	Zero	Inactive
61	F61 - SENSORPROM® err. Replace	It is not possible to rely on the data in SENSORPROM® unit any more	Active	Active
62	F62 - SENSORPROM® ID Replace	The SENSORPROM® unit ID do not comply with the product ID. The SENSORPROM® unit is from another type of product MASSFLO, SONOFLO etc.	Zero	Inactive
63	F63 - SENSORPROM® Replace	It is not possible to read from the SENSORPROM® unit any more.	Active	Active
70	F70 - Coil current Check cables	Coil excitation has failed	Active	Active
71	F71 - Internal error Replace converter	Internal conversion error in ASIC	Active	Active

9.1
Trouble shooting
MAG 5000 and 6000

Symptom	Output signals	Error code	Cause	Remedy
Empty display	Minimum		1. Supply voltage 2. MAG 5000/6000 defective	Check supply voltage Replace MAG 5000/6000
No flow signal	Minimum		1. Current output deselected 2. Digital output deselected 3. Reverse flow direction	Activate current output Activate digital output Change direction
		F70	Incorrect or no coil current	Check cables/connections
		W31	Measuring pipe empty	Ensure that the measuring pipe is full
	Undefined	F60	Internal error	Replace MAG 5000/6000
		P42	1. No load on current output 2. MAG 5000/6000 defective	Check cables/connections Replace MAG 5000/6000
		P41	Initializing error wait 5 s and switch on again	Switch off MAG 5000/6000, wait 5 s and switch on again
Indicates flow with no flow in pipe	Undefined		Measuring pipe empty Empty pipe cut-off is OFF	Select empty pipe cut-off Ensure that the measuring pipe is full
			Electrode cable is insufficiently screened	Ensure that electrode cable is connected and sufficiently screened
Unstable flow signal	Unstable		1. Pulsating flow 2. Conductivity of medium too low 3. Electrical noise potential between medium and sensor 4. Air bubbles in medium 5. High concentration of particles or fibres	Increase time constant Use special electrode cable Ensure sufficient potential equalization. Ensure medium does not contain air bubbles Increase time constant
Measuring error	Undefined		Incorrect installation	Check installation
		P40	No SENSORPROM® unit	Install SENSORPROM® unit
		F61	Deficient SENSORPROM® unit	Replace SENSORPROM® unit
		F62	Wrong type of SENSORPROM® unit	Replace SENSORPROM® unit
		F63	Deficient SENSORPROM® unit	Replace SENSORPROM® unit
	F71	Loss of internal data	Replace MAG 5000/6000	
	Maximum	W30	Flow exceeds 100% of Q_{max} .	Check Q_{max} . (Basic Settings)
W21		Pulse overflow • Volume/pulse too small • Pulse width too large	Change volume/pulse Change pulse width	
Loss of totalizer data	OK	W20	Initializing error	Reset totalizer manually

**10.1
Sensor MAG 1100**

Description	Size	Code no.	Symbol
MAG 1100 Ceramic Al ₂ O ₃ Temperature of medium max. 150°C Included: 2 EPDM gaskets, studs and nuts	DN 6	083G4044	
	DN 10	083G4046	
	DN 15	083G4047	
	DN 25	083G4049	
	DN 40	083G4051	
	DN 50	083G4052	
	DN 65	083G4053	
	DN 80	083G4054	
	DN 100 ¹⁾	083G4055	
MAG 1100 (High temperature) Ceramic Al ₂ O ₃ Temperature of medium max. 200°C Included: 2 graphite gaskets, studs and nuts	DN 15	083G4057	
	DN 25	083G4059	
	DN 40	083G4061	
	DN 50	083G4062	
	DN 80	083G4064	
DN 100 ¹⁾	083G4065		
MAG 1100 Ex Ceramic Al ₂ O ₃ Temperature of medium max. 120°C Included: 2 EPDM gaskets, studs and nuts	DN 6	083G4024	
	DN 10	083G4026	
	DN 15	083G4027	
	DN 25	083G4029	
	DN 40	083G4031	
	DN 50	083G4032	
	DN 65	083G4033	
	DN 80	083G4034	
DN 100 ¹⁾	083G4035		
MAG 1100/3000 Ex-d Ceramic Al ₂ O ₃ Temperature of medium max. 120°C Included: 2 EPDM gaskets, studs and nuts	DN 6	083G3054	
	DN 10	083G3056	
	DN 15	083G3057	
	DN 25	083G3059	
	DN 40	083G3061	
	DN 50	083G3062	
	DN 65	083G3063	
	DN 80	083G3064	
	DN 100 ¹⁾	083G3065	
MAG 1100 FOOD Ceramic Al ₂ O ₃ Temperature of medium max. 150°C Enclosure IP 67	DN 10	083G2016	
	DN 15	083G2017	
	DN 25	083G2019	
	DN 40	083G2021	
	DN 50	083G2022	
	DN 65	083G2023	
	DN 80	083G2024	
DN 100	083G2025		
MAG 1100 FOOD PFA Temperature of medium max. 130°C Enclosure IP 67 2 EPDM gaskets	DN 10	083G5066	
	DN 15	083G5067	
	DN 25	083G5069	
	DN 40	083G5071	
	DN 50	083G5072	
	DN 65	083G5073	
	DN 80	083G5074	
DN 100	083G5075		

¹⁾ The studs supplied for DN 100 are for PN 10/16 only. For use with PN 25/40, see "Accessories".

Accessories

Description	Material	DN	Code no.	Symbol
Pipe connection 1/2" external thread 2 pipe connections 2 gaskets 12 M4 screws (12 mm)	AISI 316 (1.4436) EPDM	6, 10	083G0080	
Grounding ring 1 potential equalizing ring 3 teflon gaskets 1 earth strap 1 M6 screw	AISI 316 (1.4436)	6, 10 15 25 40 50 65 80 100	083G0686 083G0687 083G0689 083G0691 083G0692 083G0693 083G0694 083G0695	
Grounding ring 1 potential equalizing ring 3 teflon gaskets 1 earth strap 1 M6 screw	Hastelloy C4	6, 10 15 25 40 50 65 80 100	083G0696 083G0697 083G0699 083G0701 083G0702 083G0703 083G0704 083G0705	
Studs and Nuts for DN 100 PN 25/40 8 M20 studs 16 M20 nuts	AISI 304 (1.4305)	100	083G0226	

**Gaskets for
MAG 1100**

Description	Material	DN	Code no.	Symbol
EPDM gaskets 2 gaskets 2 earth straps 3 M6 screws	EPDM	6, 10 15 25 40 50 65 80 100	083G3116 083G3117 083G3119 083G3121 083G3122 083G3123 083G3124 083G3125	
PTFE gaskets 2 PTFE gaskets 2 earth straps 3 M6 screws	PTFE	6, 10 15 25 40 50 65 80 100	083G0156 083G0157 083G0159 083G0161 083G0162 083G0163 083G0164 083G0165	
Graphite gaskets 2 gaskets	Graphite	6, 10 15 25 40 50 65 80 100	083G0116 083G0117 083G0119 083G0121 083G0122 083G0123 083G0124 083G0125	

**Gaskets for
MAG 1100 FOOD**

Description	Material	DN	Code no.	Symbol
EPDM gaskets 2 gaskets	EPDM	10 15 25 40 50 65 80 100	083G2206 083G2207 083G2209 083G2211 083G2212 083G2213 083G2214 083G2215	
NBR gaskets 2 gaskets	NBR	10 15 25 40 50 65 80 100	083G2216 083G2217 083G2219 083G2221 083G2222 083G2223 083G2224 083G2225	

10.2 Adaptor, MAG 1100 FOOD (contains 2 adaptors, 2 clamp rings and 2 gaskets)

Adapter DN [mm]	D _o [mm]	D _i [mm]	Sensor DN [mm]	Weld-in type: Matching standard					Symbol
				DIN 11850	DS/ISO 2037	SMS 3008	BS 4825-1	Tri-Clover®	
				Code no.	Code no.	Code no.	Code no.	Code no.	
10	13.0	10.0	10	083G2116	083G2116	083G2116	083G2116	-	
15	19.0	16.0	15	083G2117	083G2117	083G2117	083G2117	-	
15.9	15.9	13.5	15	-	-	-	-	083G2107	
20	23.0	20.0	15	083G2118	083G2118	083G2118	083G2118	-	
25	25.6	22.6	25	-	083G2109	083G2109	083G2109	-	
25	29.0	26.0	25	083G2119	-	-	-	-	
28	28.6	25.6	25	-	083G2100	-	-	-	
32	32.0	29.6	25	-	-	083G2102	-	-	
32	35.0	32.0	25	083G2120	-	-	-	-	
33.7	34.3	31.3	25	-	083G2110	083G2110	-	-	
38	38.6	35.6	40	-	083G2111	083G2111	083G2111	083G2111	
40	40.6	37.6	40	-	083G2101	-	-	-	
40	41.0	38.0	40	083G2121	-	-	-	-	
50	53.0	50.0	50	083G2122	-	-	-	-	
51	51.6	48.6	50	-	083G2112	083G2112	083G2112	083G2112	
63.5	64.1	60.3	65	-	083G2113	083G2113	083G2113	083G2113	
65	70.0	66.0	65	083G2123	-	-	-	-	
70	70.6	66.8	65	-	083G2103	-	-	-	
76	76.0	72.0	65	-	-	083G2106	-	-	
76.1	76.7	72.9	80	-	083G2114	083G2114	083G2114	083G2114	
80	85.0	81.0	80	083G2124	-	-	-	-	
88.9	88.9	84.9	80	-	083G2104	083G2104	-	-	
100	104.0	100.0	100	083G2125	-	-	-	-	
101.6	102.5	97.6	100	-	083G2115	-	-	-	
114.3	115.6	110.3	100	-	083G2105	-	-	-	

Adapter DN [mm]	D _o [mm]	D _i [mm]	Sensor DN [mm]	Clamp type: Matching standard					Symbol
				DIN 32676	DS/ISO 2852	SMS 3016	BS 4825-2	Tri-Clamp®	
				Code no.	Code no.	Code no.	Code no.	Code no.	
10	34.0	10.0	10	083G2186	083G2186	083G2186	-	-	
15	34.0	16.0	15	083G2187	083G2187	083G2187	-	-	
20	34.0	20.0	15	083G2188	083G2188	-	-	-	
25	50.5	22.6	25	-	083G2189	083G2189	083G2189	083G2189	
25	50.5	26.0	25	083G2179	083G2179	-	-	-	
33.7	50.5	31.3	25	083G2190	083G2190	083G2190	-	-	
38	50.5	35.6	40	-	083G2191	083G2191	083G2191	083G2191	
40	50.5	38.0	40	083G2181	083G2181	-	-	-	
50	64.0	50.0	50	083G2182	-	-	-	-	
51	64.0	48.6	50	-	083G2192	083G2192	083G2192	083G2192	
63.5	77.5	60.3	65	-	083G2193	083G2193	083G2193	083G2193	
65	91.0	66.0	65	083G2183	-	-	-	-	
76.1	91.0	72.9	80	-	083G2194	083G2194	083G2194	083G2194	
80	106.0	81.0	80	083G2184	-	-	-	-	
100	119.0	100.0	100	083G2185	-	-	-	-	
101.6	119.0	97.6	100	-	083G2195	-	-	-	

10.2
Adaptor, MAG 1100 FOOD
(continued)

Threaded type: Matching standard					Symbol
Adapter DN [mm]	D _o [mm]	D _i [mm]	Sensor DN [mm]	DIN 11851 Code no.	
10	28.0	10.0	10	083G2156	
15	34.0	16.0	15	083G2157	
20	44.0	20.0	15	083G2158	
25	52.0	26.0	25	083G2159	
32	58.0	32.0	25	083G2160	
40	65.0	38.0	40	083G2161	
50	78.0	50.0	50	083G2162	
65	95.0	66.0	65	083G2163	
80	110.0	81.0	80	083G2164	
100	130.0	100.0	100	083G2165	

Adapter DN [mm]	D _o [mm]	D _i [mm]	Sensor DN [mm]	Threaded type: Matching standard			Symbol
				ISO 2853	SS 3351	BS 4825-4 (IDF)	
				Code no.	Code no.	Code no.	
25	25	37.0	22.6	083G2149	083G2149	083G2149	
38	40	51.0	35.6	083G2151	083G2151	083G2151	
51	50	64.0	48.6	083G2152	083G2152	083G2152	
63.5	65	78.0	60.3	083G2153	083G2153	083G2153	
76.1	80	91.0	72.9	083G2154	083G2154	083G2154	
101.6	100	118.0	97.6	083G2155	083G2155	-	
101.6	100	126.0	97.6	-	-	083G2145	

Threaded type: Matching standard					Symbol
Adapter DN [mm]	D _o [mm]	D _i DN [mm]	Sensor [mm]	SMS 1145 Code no.	
25	40.0	22.6	25	083G2139	
32	48.0	29.6	25	083G2140	
38	60.0	35.6	40	083G2141	
51	70.0	48.6	50	083G2142	
63.5	85.0	60.3	65	083G2143	
76	98.0	72.0	65	083G2144	

Tri-Clover® and Tri-Clamp® are registered trademarks for Ladish Co.

Earthing/protection flange type C (AISI 304) for all liners except PTFE

Flange Pressure stage	DIN 2501/BS 4504					ANSI B 16.5		BS 10	JIS B 2220	
	PN 6	PN 10	PN 16	PN 25	PN 40	150 lb	300 lb	Table D/E	K 10	K 16
DN	083N...	083N...	083N...	083N...	083N...	083N...	083N...	083N...	083N...	083N...
25					8361	8361	8361	8361		
40					8362	8362	8362	8362		
50					8344	8344	8344	8344	8344	8344
65	8345		8345		8345	8345	8345	8346	8345	8345
80	8347		8347		8347	8347	8347	8347	8347	8347
100	8070		8025		8025	8025	8025	8025	8070	8025
125	8071		8071		8071	8071	8071	8071	8071	8071
150	8072		8008		8008	8008	8073	8008	8008	8325
200	8074	8011	8011	8011	8075	8011	8076	8011	8322	8011
250	8078	8013	8013	8013	8079	8013	8079	8013	8013	8324
300	8080	8012	8012	8081	8082	8012	8082	8012	8323	8081
350	8083	8039	8039	8084	8085	8039	8085	8039	8326	8327
400	8099	8100	8100	8101	8102	8100	8102	8100	8330	8331
450	8103	8103	8104	8104	8105	8104	8106	8104	8103	8333
500	8107	8107	8108	8108	8109	8107	8110	8108	8107	8335
600	8111	8111	8112	8112		8113	8114	8113	8337	8112
700	8300	8294	8294						8294	8339
800	8303	8304	8304						8304	8341
900	8306	8307	8307						8307	8342
1000	8309	8310	8310						8310	8343
1200	8312	8313	8313							
1400	8349	8353	8357							
1600	8350	8354	8358							
1800	8351	8355	8359							
2000	8352	8356	8360							

Earthing/protection flange type E (AISI 316) for PTFE liner only

Flange Pressure stage	DIN 2501/BS 4504					ANSI B 16.5		BS 10/AS 2129		JIS B 2220	
	PN 6	PN 10	PN 16	PN 25	PN 40	150 lb	300 lb	Table D	Table E		
DN	083N...	083N...	083N...	083N...	083N...	083N...	083N...	083N...	083N...		
15					8365	8365	8365	8365	8365		
25					8271	8272	8272	8272	8272		
40					8278	8275	8275	8276	8276		
50					8282	8283	8283	8281	8281		
65	8284		8285		8286	8287	8287	8284	8284		
80	8288		8289		8290	8291	8292	8293	8293		
100	8116		8117		8118	8118	8119	8117	8117		
125	8120		8121		8122	8122	8123	8121	8121		
150	8124		8125		8126	8126	8127	8128	8128		
200	8129	8130	8130	8131	8132	8370	8133	8134	8134		
250	8135	8136	8137	8138	8139	8140	8141	8142	8143		
300	8144	8144	8145	8146	8147	8148	8149	8150	8151		
350	8152	8153	8154	8155	8156	8157	8158	8159	8153		
400	8160	8161	8162	8163	8164	8165	8166	8167	8161		
450	8168	8169	8170	8171	8172	8173	8174	8175	8176		
500	8177	8178	8179	8180	8181	8182	8183	8184	8185		
600	8186	8187	8188	8189		8190	8191	8192	8193		

Accessories

Description	Code no.	Symbol
Submersible kit (IP 68, 10 m w.g.) For use with standard MAG 3100, when sensor is buried or permanently submerged.	085U0220	

10.4
Sensor MAG 3100 W



DIN flanges	DN	PN	Code no.	
			Neoprene liner	EPDM liner
Liner: Neoprene or EPDM Flanges: Mild steel, DIN 2501 Electrodes: AISI 316 Ti Grounding Electrodes: AISI 316 Ti Enclosure: IP 67	25	40	083Z8000	083Z8100
	40	40	083Z8001	083Z8101
	50	40	083Z8002	083Z8102
	65	16	083Z8003	083Z8103
	80	16	083Z8004	083Z8104
	100	16	083Z8005	083Z8105
	125	16	083Z8006	083Z8106
	150	16	083Z8007	083Z8107
	200	10	083Z8008	083Z8108
	200	16	083Z8208	083Z8308
	250	10	083Z8009	083Z8109
	250	16	083Z8209	083Z8309
	300	10	083Z8010	083Z8110
	300	16	083Z8210	083Z8310
	350	10	083Z8011	083Z8111
	350	16	083Z8211	083Z8311
	400	10	083Z8012	083Z8112
	400	16	083Z8212	083Z8312
	450	10	083Z8013	083Z8113
	450	16	083Z8213	083Z8313
500	10	083Z8014	083Z8114	
500	16	083Z8214	083Z8314	
600	10	083Z8015	083Z8115	
600	16	083Z8215	083Z8315	
700	10	083Z8016	083Z8116	
800	10	083Z8017	083Z8117	
900	10	083Z8018	083Z8118	
1000	10	083Z8019	083Z8119	
1200	10	083Z8021	083Z8121	

ANSI/AWWA flanges	Nominal size DN	Nominal size inch	Flange type	PN bar	Code no.
Liner: Neoprene Flange: Carbon steel (A 105/St. 37.2), ANSI Class 150 or AWWA C-207, Class D Electrodes: AISI 316 Ti Grounding electrode: AISI 316 Ti Enclosure: IP 67/NEMA 6 (3 m/10 ft w.g. for 72 h)	25	1"	ANSI 150	20	083Z8600
	40	1½"	ANSI 150	20	083Z8601
	50	2"	ANSI 150	20	083Z8602
	65	2½"	ANSI 150	20	083Z8603
	80	3"	ANSI 150	20	083Z8604
	100	4"	ANSI 150	20	083Z8605
	125	5"	ANSI 150	20	083Z8606
	150	6"	ANSI 150	20	083Z8607
	200	8"	ANSI 150	20	083Z8608
	250	10"	ANSI 150	20	083Z8609
	300	12"	ANSI 150	20	083Z8610
	350	14"	ANSI 150	20	083Z8611
	400	16"	ANSI 150	20	083Z8612
	450	18"	ANSI 150	20	083Z8613
	500	20"	ANSI 150	20	083Z8614
	600	24"	ANSI 150	20	083Z8615
	700	28"	AWWA	10	083Z8616
	750	30"	AWWA	10	083Z8617
	800	32"	AWWA	10	083Z8618
	900	36"	AWWA	10	083Z8619
1000	40"	AWWA	10	083Z8620	
1100	44"	AWWA	10	083Z8621	
1200	48"	AWWA	10	083Z8622	

**10.5
Signal converter**
Compact polyamid

Description	Version	Enclosure	Code no.	Symbol
Signal converter MAG 5000 Blind for compact and wall mounting	11-30 V d.c./ 11-24 V a.c.	IP 67, fibre-glass reinforced polyamid	083F5006	
	115/230 V a.c. 50/60 Hz	IP 67, fibre-glass reinforced polyamid	083F5005	
Signal converter MAG 5000 for compact and wall mounting	11-30 V d.c./ 11-24 V a.c.	IP 67, fibre-glass reinforced polyamid	083F5002	
	115/230 V a.c. 50/60 Hz	IP 67, fibre-glass reinforced polyamid	083F5001	
	115/230 V a.c. 50/60 Hz HART®	IP 67, fibre-glass reinforced polyamid	083F5011	

Description	Version	Enclosure	Code no.	Symbol
Signal converter MAG 6000 Blind for compact and wall mounting	11-30 V d.c./ 11-24 V a.c.	IP 67, fibre-glass reinforced polyamid	083F5008	
	115/230 V a.c. 50/60 Hz	IP 67, fibre-glass reinforced polyamid	083F5007	
Signal converter MAG 6000 for compact and wall mounting	11-30 V d.c./ 11-24 V a.c.	IP 67, fibre-glass reinforced polyamid	083F5004	
	115/230 V a.c. 50/60 Hz	IP 67, fibre-glass reinforced polyamid	083F5003	

Description	Version	Enclosure	Code no.	Symbol
Signal converter MAG 6000 CT for compact and wall mounting	11-30 V d.c./ 11-24 V a.c.	IP 67, fibre-glass reinforced polyamid	083F5010	
	115/230 V a.c. 50/60 Hz	IP 67, fibre-glass reinforced polyamid	083F5009	

**Accessories
MAG 5000 and MAG 6000**

Description	Code no.	Symbol
Wall mounting unit for IP 67 version Wall bracket, 4 Pg 13.5 cable glands	085U1001	

**Add-on module
MAG 6000 only**

Description	Code no.	Symbol
HART®	085U0226	

Spare parts

Description	Version	Code no.	Symbol
Connection plate	12-24 V	083F4113	
	115-230 V	083F4112	

**10.6
Signal converter 19"**

Description	Version	Code no.	Symbol
Signal converter MAG 5000 for rack and panel mounting	11-30 V d.c./ 11-24 V a.c.	083F5021	
	115-230 V a.c. 50/60 Hz	083F5020	
Signal converter MAG 6000 for rack and panel mounting	11-30 V d.c./ 11-24 V a.c.	083F5023	
	115-230 V a.c. 50/60 Hz	083F5022	
Signal converter MAG 6000 insert with safety barrier [EEx ia/ib] IIB	11-30 V d.c./ 11-24 V a.c.	083F5041	
Signal converter MAG 6000 insert with safety barrier [EEx ia/ib] IIB	115-230 V a.c. 50/60 Hz	083F5040	

Accessories

Description	Version	Code no.	Symbol
Cleaning unit for electrode cleaning 19" insert (21 TE)	115-230 V a.c. 50/60 Hz	083F5036	
Safety barrier [EEx ia] IIC for MAG 3100 Ex DN 350-2000 19" insert (21 TE)		083F5034	
Panel mounting kit for 19" insert (21 TE) IP 65 enclosure in ABS plastic for panel-front mounting		083F5030	
Panel mounting kit for 19" insert (42 TE) IP 65 enclosure in ABS plastic for panel-front mounting		083F5031	
Back of panel mounting kit for 19" insert (21 TE) IP 20 enclosure in aluminium		083F5032	
Back of panel mounting kit for 19" insert (42 TE) IP 20 enclosure in aluminium		083F5033	
Front cover (7 TE)		083F4525	

**Wall mounting units
complete**

Description	Version	Code no.	Symbol
MAG 6000 with IP 66 enclosure	115/230 V a.c. 50/60 Hz	083F5026	
MAG 6000 19" insert and cleaning unit complete mounted with IP 66 wall mounting enclosure	115/230 V a.c. 50/60 Hz	083F5029	
MAG 6000 19" insert and safety barrier complete mounted with IP 66 wall mounting enclosure, [EEx ia/ib] IIB	115/230 V a.c. 50/60 Hz	083F5028	
MAG 6000 19" insert and safety barrier complete mounted with IP 66 wall mounting enclosure, [EEx ia/e] IIC	115/230 V a.c. 50/60 Hz	083F5027	

**Wall boxes
(Without backplates)**

Description	Code no.	Symbol
IP 66 wall mounting enclosure for IP 20 19" inserts (21 TE)	083F5037	
IP 66 wall mounting enclosure for IP 20 19" inserts (42 TE)	083F5038	

Backplates

Description	Enclosure	Version	Code no.	Symbol
Signal converter	19"	12-24 V 115-230 V	083F4117	
Signal converter & ia, safety barrier	19"	12-24 V 115-230 V	083F4118	
Signal converter & ia/ib, safety barrier	19"	12-24 V 115-230 V	083F4119	
Signal converter & cleaning unit	19"	115-230 V	083F4123	
Signal converter	Wall unit	12-24 V 115-230 V	083F4121	
Signal converter & ia, safety barrier	Wall unit	12-24 V 115-230 V	083F4122	
Signal converter & ia/ib, safety barrier	Wall unit	12-24 V 115-230 V	083F4120	
Signal converter & cleaning unit	Wall unit	115-230 V	083F4124	

10.7 Accessories

Description		Code no.	Symbol
Cable Standard electrode and coil cable, 3 x 1,5 mm ² PVC	Length		
	10 m	083F0121	
	20 m	083F0210	
	40 m	083F0211	
	60 m	083F0212	
	100 m	083F0213	
	150 m	083F3052	
	200 m	083F3053	
500 m	083F3054		
Cable Special electrode cable, double screened, PVC	20 m	083F3095	
	40 m	083F3094	
	60 m	083F3093	
	100 m	083F3092	
	150 m	083F3056	
	200 m	083F3057	
500 m	083F3058		
Standard Pg 13.5 screwed cable entries for above cables (nickel-plated brass)	2-off	083G0227	
Standard Pg 13.5 screwed cable entries for above cables in black polyamide (100°C)	2-off	083G0228	
Sealing screws for sensor/signal converter	2-off	085U0221	
Stainless steel (AISI 316) terminal box with lid		085U1000	
Polyamid terminal box Complete incl. terminals excl. lid		085U1002	
Polyamid lid for terminal box		085U1003	
2 kB SENSORPROM® unit (Sensor serial no. must be specified by ordering)		085U1005	

10.8 Calibration

Initial calibration

Description	Code no. DN 3-65	Code no. DN 80-150	Code no. DN 200-500	Code no. DN 600-1200
Standard calibration Each sensor calibrated twice at two calibration points Included in sensor scope of delivery				
Matched pair Sensor and signal converter calibrated together with standard calibration	085F7351	085F7351	085F7351	085F7351
Customer specified matched pair Sensor with signal converter are calibrated in max. 10 customer specified points	085F7372	085F7373	085F7374	085F7375
Accredited Danfoss matched pairs Calibrations acc. to EN 45001 Sealing and labeling instruction must follow the order - PTB cold water - PTB other media than water - OIML 75 hot water - OIML 117 other media than water - OIML 117 cold water	085F7382	085F7383	085F7384	085F7385
Accredited Delft matched pair Calibration acc. to EN 45001 Sealing and labeling instruction as above	N/A	085F7393	085F7394	085F7395
Matched pair Sensor and signal converter calibrated together with standard calibration	085F7302	085F7303	085F7304	085F7305
Customer specified matched pair Sensor with signal converter are calibrated in max. 10 customer specified points	085F7377	085F7378	085F7379	085F7380
Accredited Danfoss matched pairs Calibrations acc. to EN 45001 Sealing and labeling instruction must follow the order - PTB cold water - PTB other media than water - OIML 75 hot water - OIML 117 other media than water - OIML 117 cold water	085F7387	085F7388	085F7389	085F7390
Accredited Delft matched pair Calibration acc. to EN 45001 Sealing and labeling instruction as above	N/A	085F7393	085F7394	085F7395
Wittnes inspection Any of above mentioned calibrations	083F7361			

Re-calibration

Add-on

The Danfoss Flow range contains:



MAGFLO® electromagnetic flowmeters

MAGFLO® flowmeters are used for all electrically conductive liquids.

A wide range is offered for:

- The water treatment sector – enclosures are IP 67 as standard.
- The chemical industry – Ex-approved and other versions available.
- The food industry – stainless steel and other versions available.



SONOFLO® ultrasonic flowmeters

SONOFLO® flowmeters measure flow in full pipes.

SONOFLO® flowmeters measure media in liquid form, irrespective of electrical conductivity.

The range includes a one- to four-track flowmeter, SONO 3000. The meter is also available in a compact Ex-version.

SONOFLO® flowmeters can also be installed on existing pipes, providing low cost installations, especially where large pipes are concerned.



MASSFLO® mass flowmeters

MASSFLO® flowmeters measure flow direct in kg/h. In addition, MASSFLO® flowmeters measure:

- Density
- Temperature
- Sugar concentration i.e. °Brix

MASSFLO® flowmeters are available in stainless steel, Hastelloy and with integrated heating.

MASSFLO® flowmeters can be obtained in an intrinsically safe version for explosive areas.



SONOCAL® ultrasonic heat meter

SONOCAL® serie 3000 ultrasonic heat meter.

SONOCAL® serie 2000 ultrasonic heat meter.

MASSFLO®, MAGFLO®, SONOFLO®, SONOCAL® and SENSORPROM® are registered Danfoss trademarks.

Danfoss can accept no responsibility for possible errors in catalogues, brochures and other printed material. Danfoss reserves the right to alter its products without notice. This also applies to products already on order provided that such alterations can be made without subsequential changes being necessary in specifications already agreed. All trademarks in this material are property of the respective companies. Danfoss and the Danfoss logotype are trademarks of Danfoss A/S. All rights reserved.