

GENERAL

Badger's Magnetoflow line is the result of 35 years of research and field use in electromagnetic flow meters. Based on Faraday's law of induction, these meters can measure almost any liquid, slurry or paste that has a minimum level of electrical conductivity. Designed, developed and manufactured under the strictest quality standards, the Magnetoflow meter ranks among the best in the market. It's sophisticated, processor based signal conversion represents the state of the art in the industry with accuracies of 0.25% or better. The wide selection of liner and electrode materials insures maximum compatibility and minimum maintenance over a long operating period.

OPERATION

The flow meter is basically a stainless steel tube lined with a non-conductive material. Outside the tube two DC powered electromagnetic coils are positioned diametrically opposing each other. Perpendicular to these coils, two electrodes are inserted into the flow tube. When the coils are energized, a magnetic field is created across the whole diameter of the pipe. When a conductive fluid flows through this magnetic field, a voltage is induced across the electrodes. This voltage is directly proportional to the average flow velocity of the fluid and is picked up by the two electrodes. This induced voltage is then amplified and processed digitally by the converter to produce a very accurate analog or digital signal. The signal can then be used to indicate flow rate, totalization or to communicate to remote sensors and controllers. The main advantages of this technology are that with no parts in the flow stream, there is no pressure loss, the accuracy is not affected by temperature, pressure, viscosity, density or flow profile and with no moving parts, there is practically no maintenance required.

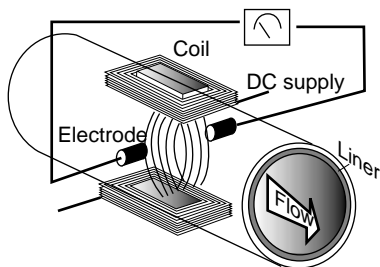

APPLICATION

Because of its inherent advantages over other more conventional technologies, this meter can be used in the majority of industrial flow applications. Whether the fluid is water or something highly corrosive, very viscous, contains a moderate amount of solids or requires special handling, this meter will be able to accurately measure it. Today Magnetoflow meters are successfully being used in most industries including food and beverage, pharmaceutical, water and waste water, and chemical.



Magnetoflow Wafer

FEATURES

- 0.25% accuracy independent of fluid viscosity, density and temperature
- Unaffected by most solids contained in fluids
- Pulsed DC magnetic field for zero point stability
- No pressure loss for low operational costs
- Long life corrosion resistant liner PTFE
- Calibrated in state of the art facilities
- Integral and remote signal converter availability
- Optional grounding electrode available
- Measurement largely independent of flow profile
- Measures fluids with as low as 0.5 micromhos/cm conductivity



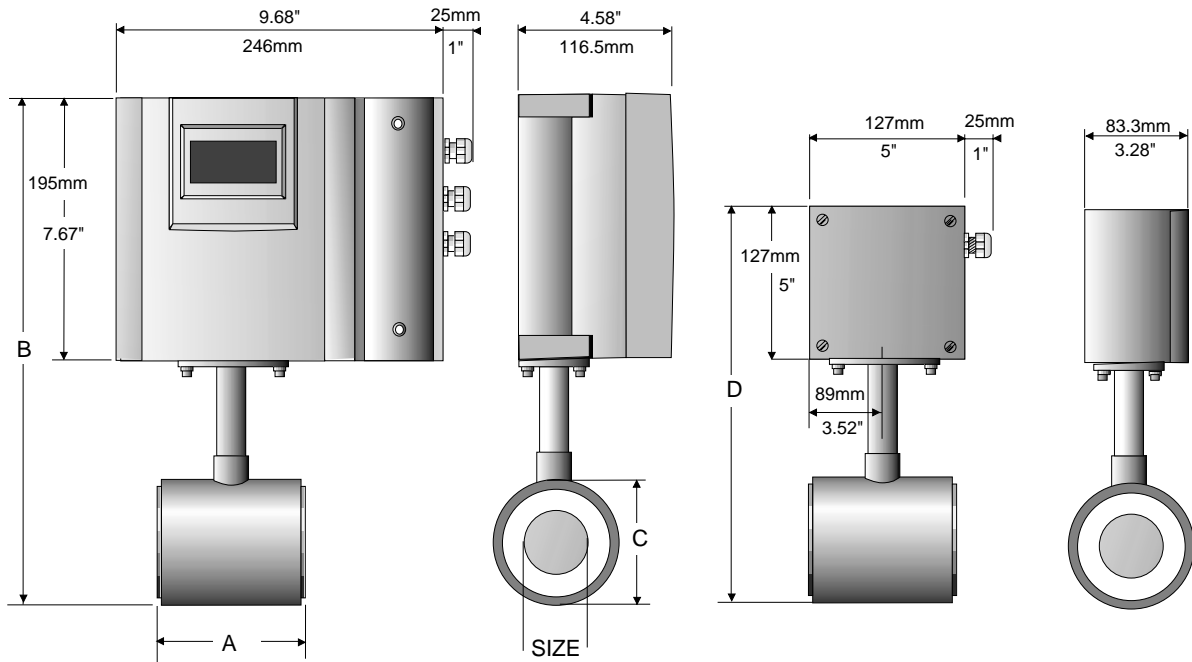

Meter with Primo® converter

Meter with junction box for remote Primo® converter

		A		B		C		D		Est. Weight with Primo		Flow Range			
												GPM		LPM	
inches	mm	inch	mm	inch	mm	inch	mm	inch	mm	Lbs	Kg	Min	Max	Min	Max
1"	25	4	100	14	349	3	74	11.2	286	20	9.0	0.24	80	0.92	305
1 1/4"	32	4	100	14.5	360	3.4	85	11.7	297	22	10.0	0.4	126	1.45	477
1 1/2"	40	4	100	14.8	370	3.8	95	12	307	23	10.5	0.6	181	2.1	687
2"	50	4	100	15.4	385	4.4	110	12.6	322	28	12.5	1.0	323	3.7	1223
2 1/2"	65	6	150	16.2	405	5.2	130	13.5	342	54	24.5	1.5	504	5.8	1910
3"	80	6	150	16.6	415	5.6	140	13.8	352	56	25.5	2.2	727	8.3	2751
4"	100	6	150	17.4	435	6.4	160	14.6	372	58	26.5	4.0	1292	14.8	4892

SPECIFICATIONS

Flow Range: 0.1 - 33 fps (0.03-10 m/s)

Sizes: 1" to 4" (25 to 100 mm)

Min. Conductivity: ≥ 0.5 micromhos/cm

Accuracy: ≥ 0.25% accuracy of rate from 1-33 fps.

≥ 0.5% accuracy of rate from .1-1 fps.

Electrode Materials: Standard: Alloy C

Optional: 316 Stainless Steel, Gold/Platinum Plated, Tantalum, Platinum/Rhodium

Liner Material: PTFE

Fluid Temperature: With Remote Converter:

PTFE 311°F, (155°C)

With Meter Mounted Converter: PTFE 212°F, (100°C)

Pressure Limits: 600psi, (40Bar)

Coil Power: Pulsed DC

Ambient Temperature: -4°F to 122°F, (-20°C to 50°C)

Pipe Spool Material: 316 Stainless Steel

Meter Enclosure Material: Carbon Steel welded

Meter Enclosure Classification: Nema 4

Junction Box Enclosure Protection: (For Remote Converter

Option) Powder coated die-cast aluminum, Nema 4

Cable Entries: 1/2" NPT Cord Grip



Please see our website at
www.badgermeter.com
 for specific regions and contacts.

Due to continuous research, product improvements and enhancements, Badger Meter reserves the right to change product or system specifications without notice, except to the extent an outstanding bid obligation exists.



BadgerMeter, Inc.

P.O. Box 245036, Milwaukee, WI 53224-9536

Telephone: (414) 355-0400 / (877) 243-1010

Fax: (414) 355-7499 / (866) 613-9305

www.badgermeter.com