



High Performance Coriolis Flowmeters

ULTRAmass MKII

Transmitter : CT9401, MT9411

GENERAL SPECIFICATION

GS.No.GBN053E-12

■ GENERAL

The know-how and experience gained in our specialized domain of manufacturing flowmeters have been used in the development of a new general-purpose Coriolis flowmeter, the ULTRAmass MKII, which is characterized by ease of operation, increased performance and safety for the plant operator.

■ FEATURES

1. Exceptional accuracy ($\pm 0.1\%$ \pm zero stability error of reading for liquid service) and high sensitivity (measuring range 1 to 200).
2. Accepts both liquid and gas. Measures accurately with small pressure loss over a broad flow range.
3. Measures density and temperature accurately in addition to mass flowrate.
4. Minimum pockets for the process fluid to stay (in vertical installation) offers ease of cleaning.
5. Applicable to a widely varying kinds of process fluid thanks to stainless steel or all Hastelloy components.
6. Lightweight and compactly built, yet exceptionally high mechanical strength. The result is ease of handling, installation space saving, and increased process safety.

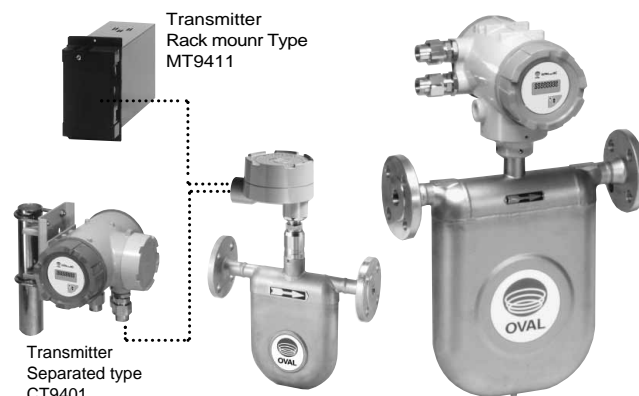

7. The transmitter comes in two types - integrally mounted to, or separately mounted from the sensor. Select one for your particular application.
8. Also available is a sophisticated transmitter with a local display to show variables, such as the flowrate, density, and temperature, at the touch of a display panel.
9. Explosionproof configuration permits meter installation in a hazardous location.

■ GENERAL SPECIFICATIONS

● Standard sensor unit

Item		Description						
Model		CN003(※1)	CN006	CN010	CN015	CN025	CN050	CN080
Nominal size		10mm or $3/8"$ (※2)		15mm or $1/2"$		25mm or $1"$ 40mm or $1\frac{1}{2}"$		50mm or $2"$ 80mm or $3"$
Materials	Wetted	SUS316L, SUS316L +Alloy C, Alloy C						
	Housing	SUS304						
Process connection		JIS 10, 20, 30, 40, 63K RF, ANSI/JPI 150, 300, 600RF, IDF ferrule (※3), Screw						
Applicable fluids		Liquids and gases						
Density range		0 to 2.0 g/mL						
Temperature range (※4)	Non-explosionproof type		-200 to +200°C					
	Configuration	Ex. temp. grade	-20 to +200°C					
	Hi temp. separate	T2	-20 to +130°C (CN003 only as separate type) : -20 to +165°C)					
	Integrate or separate	T3	-20 to +105°C (CN003 is separate type)					
	Integrate	T4						
Tube withstand (at 20°C)		9.4MPa (※5)						
Max. operating pressure		Max. 9.4 MPa (Depends on flange rating) (※5)						
Sensor housing withstand (MPa)(※7)		7.2	3.8	3.0	2.2	1.6	1.8	1.4
Flow direction		Forward and reverse, both available						
Applicable EU directive		ATEX Directive : 94/9/EC						
Applicable EN standard		ATEX Directive : EN50021 : 1999						
Explosionproof symbol	T I I S	Intrinsically safety explosionproof (Exib II BT3 or Exib II BT4) (※7)						Exib II AT3 or Exib II AT4 (※7)
	A T E X	Intrinsically safety explosionproof (Exib II BT2) (※8)						
Enclosure protection class		Type n explosionproof (EExnL II BT3) (※9)						
		IP66						

(※1) : Transmitter compatible with CN003 is remote mount type (CT9401-R) or rack mount type (MT9411).

(※2) : $1/2"$ for ANSI and JPI flanged sensors.

(※3) : For IDF ferrule connection, there are no CE Mark compliant products available.

(※4) : In high temperature applications exceeding 120°C, select either remote mount transmitter (CT9401-R) or rack mount transmitter (MT9411).

(※5) : High pressure service models (CN010: 36MPa and CN015: 43MPa) available only for CN010 and CN015. For details, see Product GS sheet for high pressure service models.

(※6) : This pressure does not represent the maximum working pressure in the pressure vessel ratings. It represents, based upon comparison between the results of breakdown test conducted at the OVAL (distorted enclosures are permissible) and the breakdown pressure in the FEM analysis, the one quarter (1/4) of the pressure obtained, whichever is lower (safer).

(※7) : This explosionproof configuration is system approved for explosionproof rating with the sensor unit and transmitter combined.

(※8) : This explosionproof enclosure obtained certification for explosionproof equipment on an individual basis for the sensor unit alone. (Applicable to high temperature service models except for CN003.)

(※9) : This explosionproof enclosure is valid only for use in combination with separately-located transmitter (CT6401-R).

※ : Miscellaneous: For products conforming to the high pressure gas safety regulations and CE marking, consult our representative.

OVAL Corporation

<http://www.oval.co.jp>

Head Office (Tokyo): Tel. 81-3-3360-5121. Fax. 81-3-3365-8605

Beijing Office: Tel. 86-10-5867-4711. Fax. 86-10-5867-4713

Overseas Branch Offices: Seoul, Singapore and Taipei

● **Standard sensor unit Local mount transmitter (CT9401)**

Item	Description
Power supply	85 to 264VAC 50/60Hz or 20 to 30VDC (※1)
Power consumption	Max. 25VA or Max. 10W
Ambient temperature	-20 to +50°C (without dew condensation)
Transmission length (separate type)	Max. 200m (Exclusive cable used) (※2)
Applicable EU directive	EMC Directive: 89/336/EEC, 92/31/EEC, 93/68/EEC ATEX Directive: 94/9/EC
Applicable EN standard	EMC: EN55011: 1998/A1: 1999 Group 1 Class B EN61000-6-2: 1999 ATEX: EN50021: 1999
Explosionproof enclosure	TIIS Combined explosionproof Exd[ib] IIBT3 or Exd[ib] IIBT4 (CN080: Exd[ib] IAT3 or Exd[ib] IAT4)(※3) Exd[ib] IIBT2 (※4)
	ATEX EExnC [nL] IIBT3 (※5)
Dust and waterproof configuration	IP66
Mounting	Integrate or separate mounted (CN003 and high temp. sensor of remotely located type only.)
Finish	Munsell 7.5G7/2.5
Display	8-digit (7-segment) LDC display
Weight	Integrate type: 4.6kg approx., separate type: 5.8kg approx.
Communication interface	Bell 202 (HART protocol) (※6)
Pulse output (※7)	Open collector output (10V min. to 30Vmax., 50mA DC) , FS:0.1 to 10000Hz, or Voltage pulse (option) "0": 1.5V max. "1": 15V min., Output impedance 2.2kΩ
Analog output (※7)	4 to 20mADC (max. load 600Ω) Two outputs from instantaneous flow rate (mass, volume) temperature or density. Additional damping: flow 1sec, density 4sec, temperature 2.5sec.
Status output	Open collector output Normal: ON; Abnormal: OFF (Max.30V, 50mADC) Select one from Error (std.), flow direction, Hi/Lo alarm
Status input	Contact-closure input (Form "a" contact) Close: 200Ω max., Open: 100kΩ min. Select one from Function OFF (default), remote zero, total reset, and 0% signal lock.

(※1) : CE-marking compliant models apply only to DC powered, non-explosionproof specification.

(※2) : 1/2" for ANSI and JPI flanged sensors.

(※3) : This construction meets the requirements for system certified explosionproof approved for sensor unit and transmitter combined.

(※4) : This explosionproof enclosure obtained certification for explosionproof equipment on an individual basis for the transmitter alone.
(applicable when used in combination with high temperature service sensor except for CN003.)

(※5) : This explosionproof enclosure is applicable to remotely located type only.

(※6) : Bell 202 is superimposed on analog output 1 (when combined with Smart Communication unit: Link Top).

(※7) : Flow signal is cutoff below 0.3% of the maximum permissible flowrate.

(※8) : When voltage pulse is your choice, analog output is not available.

(※9) : Of error outputs, "auto zero in progress" status output can be set up.

※ : Insulation resistance and dielectric strength tests are unacceptable.

● **Standard sensor unit Rack-mount transmitter (MT9411)**

Item	Description
Power supply	85 to 264VAC 50/60Hz or 20 to 30VDC
Power consumption	Max. 25VA or Max. 10W
Temperature	-200 to +200°C
Ambient temperature	-10 to +50°C (without dew condensation)
Transmission length (separate type)	Max. 200m (Exclusive cable used) (※1)
Explosionproof enclosure TIIS	Combined explosionproof Exd[ib] IIB (※2) or Exd[ib] IIC (※3)
Mounting	Rack-mount typy
Finish	Munsell N6.0 (grey)
Weight	1.8kg approx.
Communication interface	Bell 202 (HART protocol) (※4)
Pulse output (※5)	Open collector output (10V min. to 30Vmax., 50mA DC) , FS:0.1 to 10000Hz, or Voltage pulse (option) "0": 1.5V max. "1": 15V min., Output impedance 2.2kΩ
Analog output (※5)	4 to 20mADC (max. load 600Ω) Two outputs from instantaneous flow rate (mass, volume) temperature or density. Additional damping: flow 1sec, density 4sec, temperature 2.5sec.
Status output	Open collector output Normal: ON; Abnormal: OFF (Max.30V, 50mADC) Select one from Error (std.), flow direction, Hi/Lo alarm
Status input	Contact-closure input (Form "a" contact) Close: 200Ω max., Open: 100kΩ min. Select one from Function OFF (default), remote zero, total reset, and 0% signal lock.
Output to density computer	Natural frequency output : EL4001 series

(※1) : If it exceeds 200 meters, consult the factory.

(※2) : This explosionproof construction is a system approved for explosionproof rating with the sensor unit and transmitter combined.

(※3) : This explosionproof enclosure obtained certification for explosionproof equipment on an individual basis for the transmitter alone.
(applicable when used in combination with high temperature service sensor except for CN003.)

(※4) : Bell 202 is superimposed on analog output 1 (when combined with Smart Communication unit: Link Top).

(※5) : Flow signal is cutoff below 0.3% of the maximum permissible flowrate.

※ : CE-marking compliant products are not available.

■ GENERAL PERFORMANCE

Item		Description							
Model		CN003	CN006	CN010	CN015	CN025	CN050	CN080	
Flow rate	Normal flow range (kg/min)	0 to 1.2	0 to 6	0 to 20	0 to 60	0 to 180	0 to 650	0 to 2000	
	Allowable flow range (kg/min)	0 to 2.4	0 to 12	0 to 40	0 to 120	0 to 360	0 to 1300	0 to 4000	
	Min. range (kg/min)	0 to 0.06	0 to 0.3	0 to 1	0 to 3	0 to 9	0 to 32.5	0 to 100	
	Accuracy in factory calibration	Liquids	[±0.1% ± zero stability error] of RD						
		Gases	[±0.5% ± zero stability error] of RD						
	Repeatability	Liquids	[±0.05% ± 1/2 zero stability error] of RD						
Gases		[±0.25% ± 1/2 zero stability error] of RD							
Zero stability (kg/min)		0.00012	0.0006	0.002	0.006	0.018	0.065	0.2	
Density	Measuring range	0.3 to 2g/mL							
(Liquids)	Accuracy in factory calibration (option)	±0.001g/mL							
Analog accuracy		±0.1% of FS added to each accuracy							

$$\text{Zero stability error} = \frac{\text{Zero stability (kg/min)}}{\text{Flow rate at that time (kg/min)}} \times 100\%$$

(※1) : For volume flowrate measurement in custom or custody transfer application, contact us.

(※2) : In gas measurement, the max. permissible flow velocity varies with the type of gas and some may be beyond the bounds of measurement. If such is the case, seek our technical assistance.

■ DISPLAY

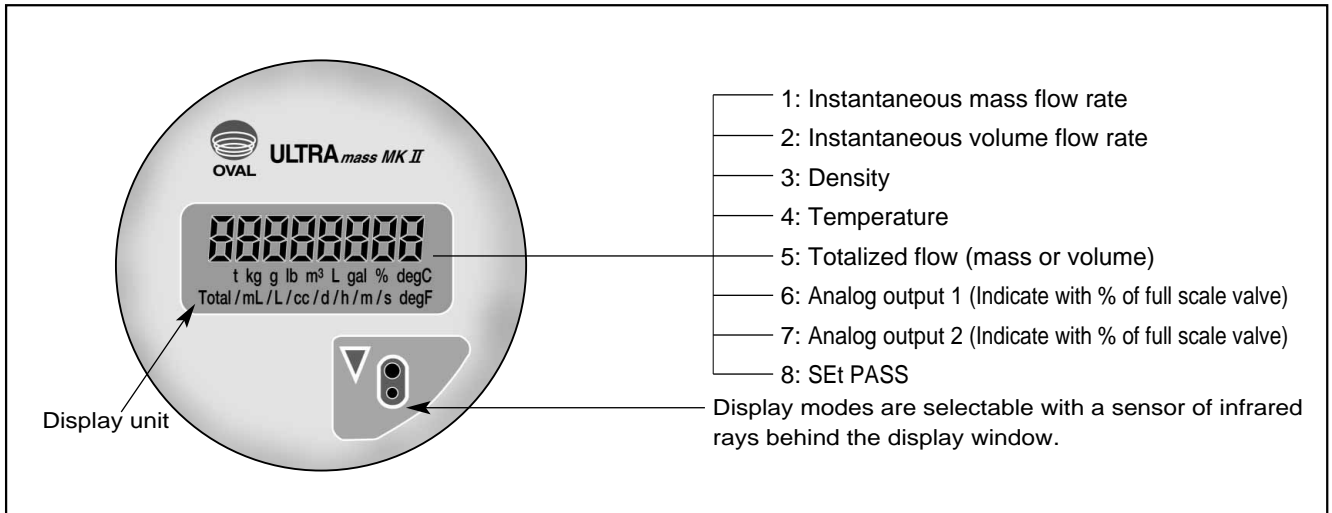

■ METER ERROR

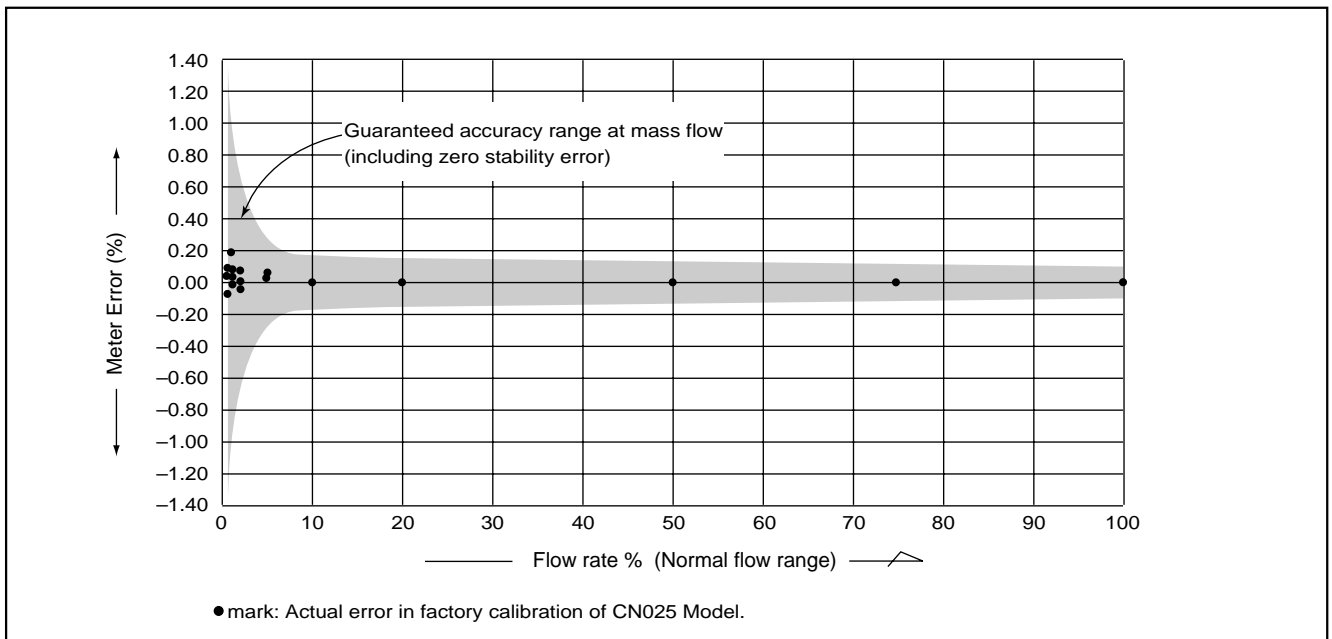

■ PRESSURE LOSS

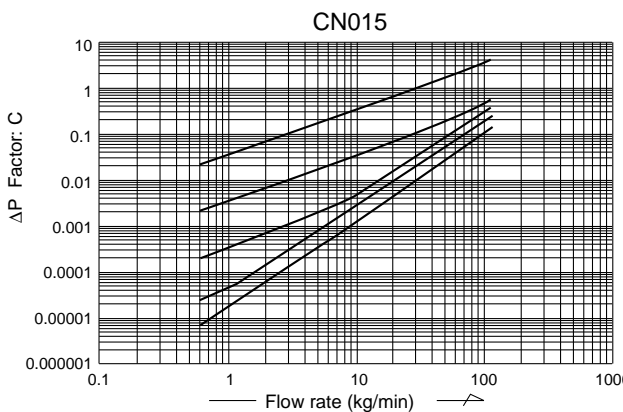
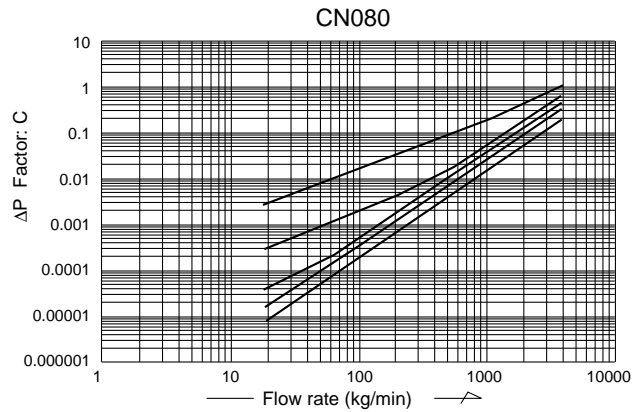
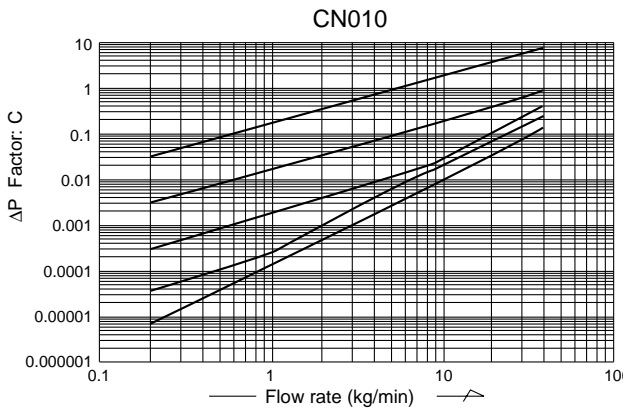
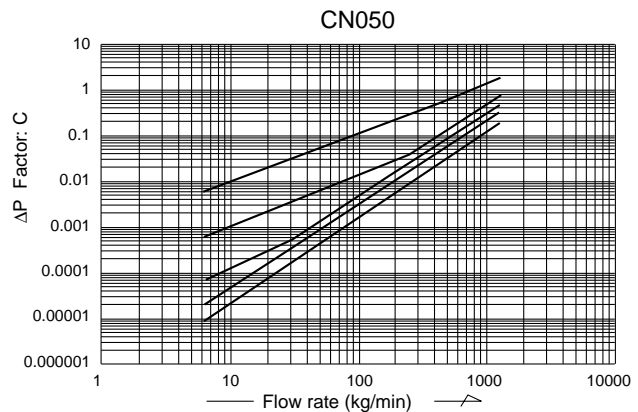
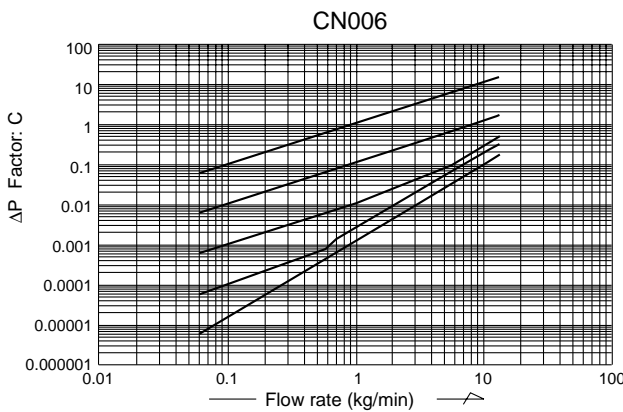
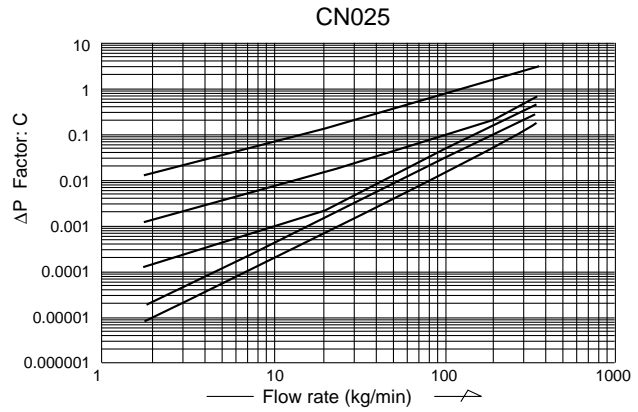
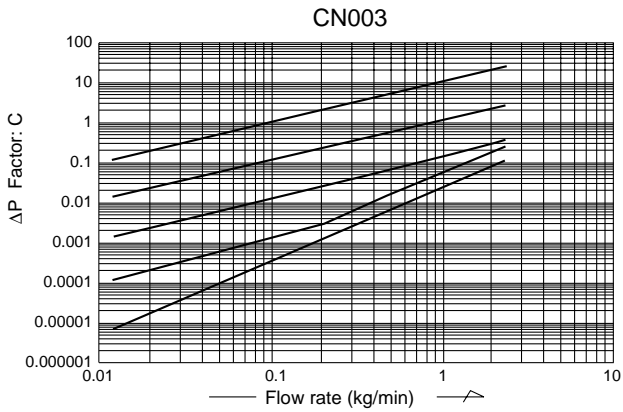

NOTE: Curves for Models CN003 through CN080 show pressure losses relative to viscosities (from top to bottom) 1000, 100, 10, 1, 0.01 (mPa·s).

How to determine pressure loss

1. Find the pressure loss factor C from flow rate (kg/min) and viscosity (mPa·s) of parameter. Dividing the obtained value C by specific gravity d (1 for water) gives the pressure loss. That is,

$$\Delta P = \frac{C}{d} \text{ (MPa)}$$

2. For high viscosity liquids not shown in these graphs, calculate the pressure loss by the following formula:

$$\Delta P_2 = C \times \frac{\mu_2}{\mu_1} \times \frac{1}{d}$$

where ΔP_2 : Pressure loss of high viscosity liquid (MPa)
 μ_2 : Viscosity of high-viscosity liquid (mPa·s)
 d : Specific gravity of high-viscosity liquid (1 for water)
 μ_1 : Max. viscosity shown in the graph (mPa·s)
 C : Pressure loss factor found from the max. viscosity curve at a given flow rate (kg/min).

■ DIMENSIONS [Unit in mm]

● Transmitter integrate type

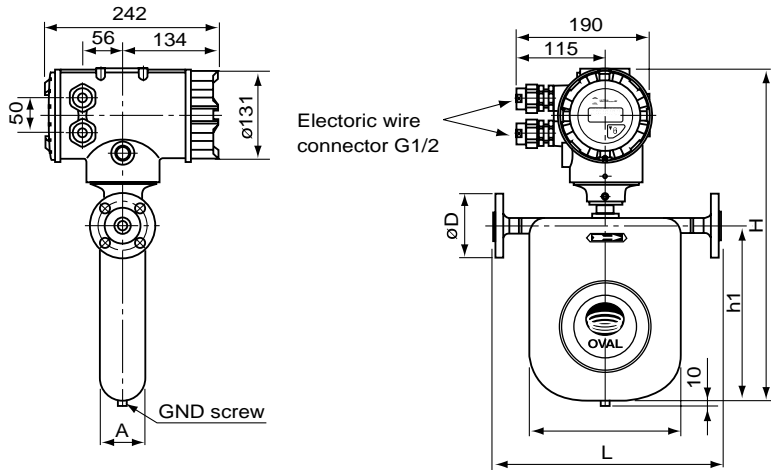

Model	Nominal size	JIS										ANSI, JPI						H	h1	A	W	Approx. Weight kg (JIS10K)
		10K		20K		30K		40K		63K		150		300		600						
		L	φD	L	φD	L	φD	L	φD	L	φD	L	φD	L	φD	L	φD					
CN006	10 (3/8")	242	90	242	90	260	110	260	110	280	115	268	89	277	95	289	95	413	180	53	148	8.8
CN010	15 (1/2")	256	95	256	95	276	115	276	115	294	120	282	89	291	95	303	95	451	218	53	163	8.8
CN015	15 (1/2")	299	95	299	95	319	115	319	115	343	120	325	89	334	95	347	95	501	268	65	205	9.8
CN025	25 (1")	380	125	380	125	400	130	400	130	422	140	411	108	424	124	437	124	569	329	83	262	14.3
CN050	40 (1 1/2")	513	140	513	140	541	160	541	160	585	175	547	127	560	155	575	155	699	452	121	385	26.8
	50 (2")	513	155	523	155	561	165	561	165	595	185	550	152	563	165	582	165					26.8
CN080	80 (3")	657	185	675	200	725	210	725	210	771	230	699	190	717	210	737	210	869	602	174	510	49.8

※ : Flange size for model CN006 is 1/2" in case of ANSI or JPI.

This table is applied to material code SS, SH. In case of code HY, please consult our representative.

CN003 Transmitter separate type.

※ : Irrespective of flange rating, a flange thickness having a higher rating is selected as long as the flange O.D. and bolt holes remain the same.

● Transmitter integrate type w/ferrule connection

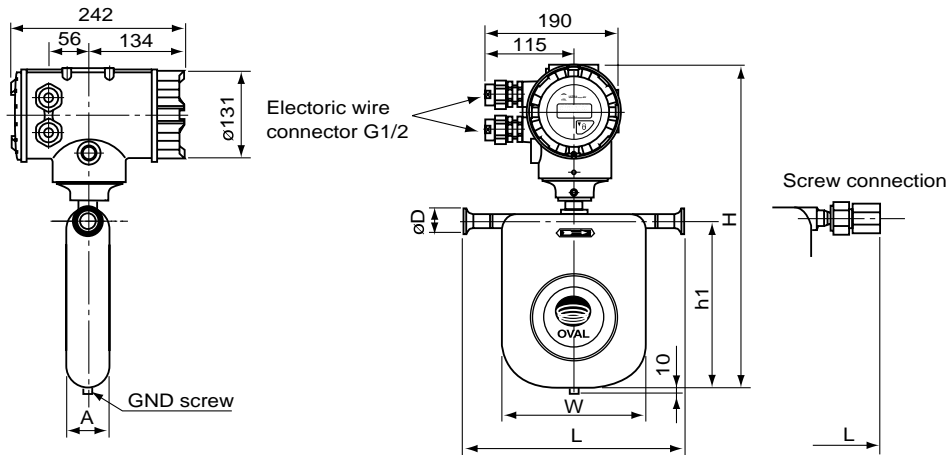

Model	Ferrule Connection		L	H	h1	A	W	φD	Approx. Weight (kg)
	Nom. size	Connection							
CN006	10	10A	232	413	180	53	148	34	6.7
CN010	15	15A	256	451	218	53	163	34	7.3
CN015	15	15A	289	501	268	65	205	34	8.1
CN025	25	25 (ISO), IDF 1S	370	569	329	83	262	50.5	11.7
CN050	40	38 (ISO), IDF 1.5S	493	699	452	121	385	50.5	20.2
	50	51 (ISO), IDF 2S						64	
CN080	80	76.1 (ISO), IDF 3S	659	869	602	174	510	91	51.8

Model	Screw	L	Weight kg
CN006	Rc 3/8	296	6.7
CN010	Rc 3/8	312	7.3
CN015	Rc 3/4	382	8.1

※ : CN003 Transmitter separate type.

• Transmitter separate type sensor unit flanged connection

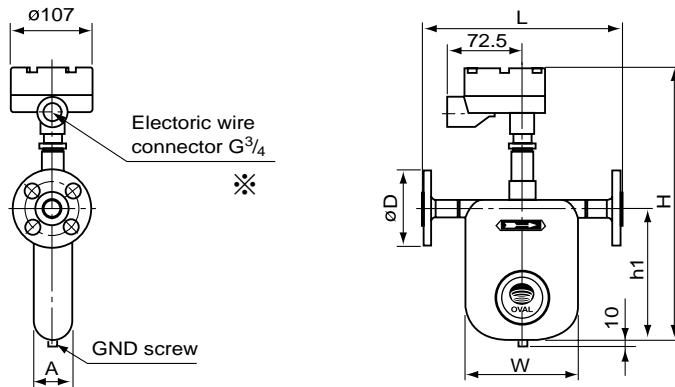

※:ATEX compliant products are provided with G1/2 adapter (fixed at cable entry).

Model	Nominal size	JIS										ANSI, JPI						H	h1	A	W	Approx. Weight kg (JIS10K)
		10K		20K		30K		40K		63K		150		300		600						
		L	ϕD	L	ϕD	L	ϕD	L	ϕD	L	ϕD	L	ϕD	L	ϕD	L	ϕD					
CN003	10($3/8$ "	275	90	275	90	293	110	293	110	313	115	301	89	310	95	322	95	388	186	49	179	5.3
CN006	10($3/8$ "	242	90	242	90	260	110	260	110	280	115	268	89	277	95	289	95	368	180	53	148	4.0
CN010	15($1/2$ "	256	95	256	95	276	115	276	115	294	120	282	89	291	95	303	95	406	218	53	163	4.7
CN015	15($1/2$ "	299	95	299	95	319	115	319	115	343	120	325	89	334	95	347	95	456	268	65	205	5.6
CN025	25(1"	380	125	380	125	400	130	400	130	422	140	411	108	424	124	437	124	524	329	83	262	10.4
CN050	40($1 1/2$ "	513	140	513	140	541	160	541	160	585	175	547	127	560	155	575	155	654	452	121	385	19.8
	50(2"	513	155	523	155	561	165	561	165	595	185	550	152	563	165	582	165					20.2
CN080	80(3"	657	185	675	200	725	210	725	210	771	230	699	190	717	210	737	210	824	602	174	510	53.6

※ : Flange size for model CN003 or CN006 is 1/2" in case of ANSI or JPI.

This table is applied to material code SS, SH. In case of code HY, please consult our representative.

※ : Irrespective of flange rating, a flange thickness having a higher rating is selected as long as the flange O.D. and bolt holes remain the same.

• Transmitter separate type sensor unit ferrule or screw connection

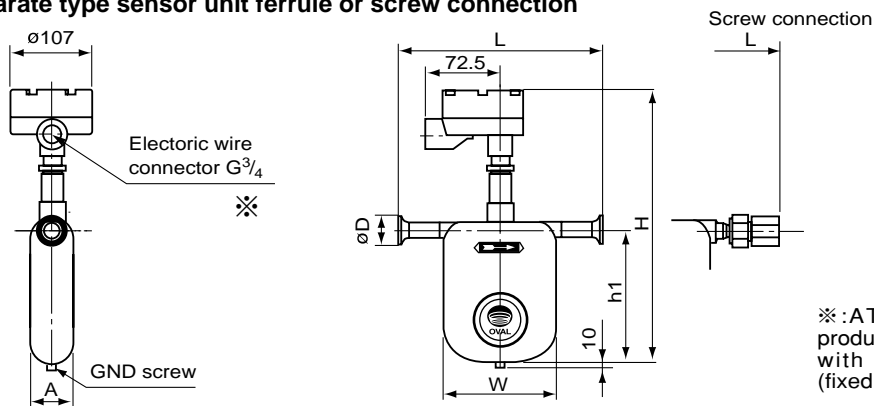

※:ATEX compliant products are provided with G1/2 adapter (fixed at cable entry).

Model	Ferrule Connection		L	H	h1	A	W	ϕD	Approx. Weight (kg)
	Nom. size	Connection							
CN003	10	10A	265	388	186	49	179	34	4.1
CN006	10	10A	232	368	180	53	148	34	2.8
CN010	15	15A	256	406	218	53	163	34	3.4
CN015	15	15A	289	456	268	65	205	34	4.2
CN025	25	25 (ISO), IDF 1S	370	524	329	83	262	50.5	7.8
CN050	40	38 (ISO), IDF 1.5S	493	654	452	121	385	50.5	16.3
	50	51 (ISO), IDF 2S						64	
CN080	80	76.1 (ISO), IDF 3S	659	824	602	174	510	91	47.9

Model	Screw	L	Weight kg
CN003	Rc 3/8	332	4.1
CN006	Rc 3/8	296	2.8
CN010	Rc 3/8	312	3.4
CN015	Rc 3/4	382	4.2

■ DIMENSIONS [Unit in mm]

Local mount type transmitter (CT9401)

- Stand on type (Pipe support)

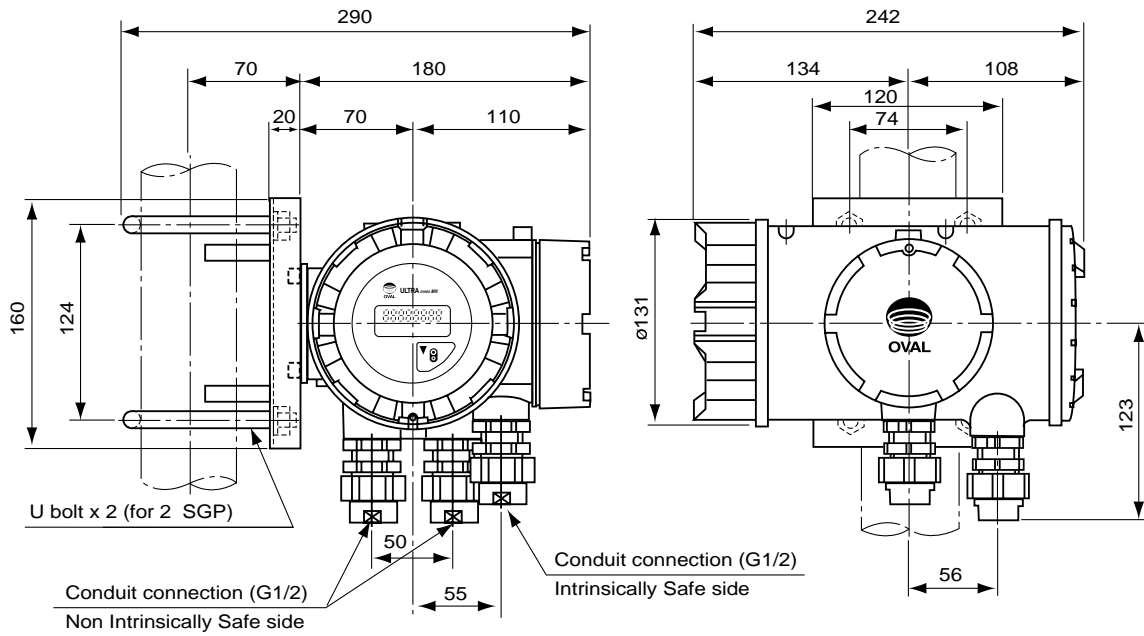

※ : ATEX compliant models are not provided with cable gland as standard accessory (option).

※ : The customer to furnish the stanchion.

Rack mount type transmitter (MT9411)

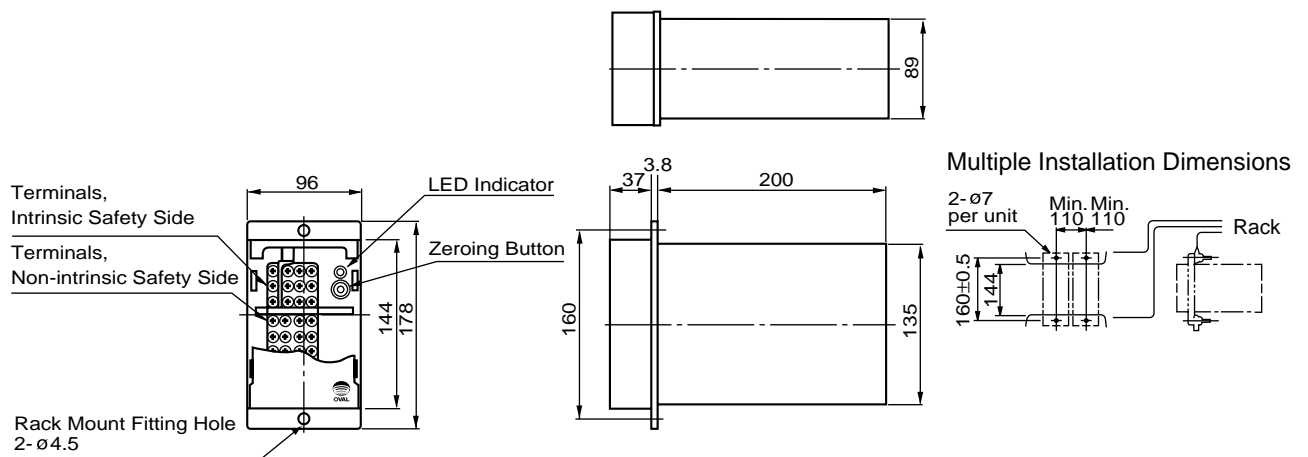

■ REMOTE MEASURING SYSTEM

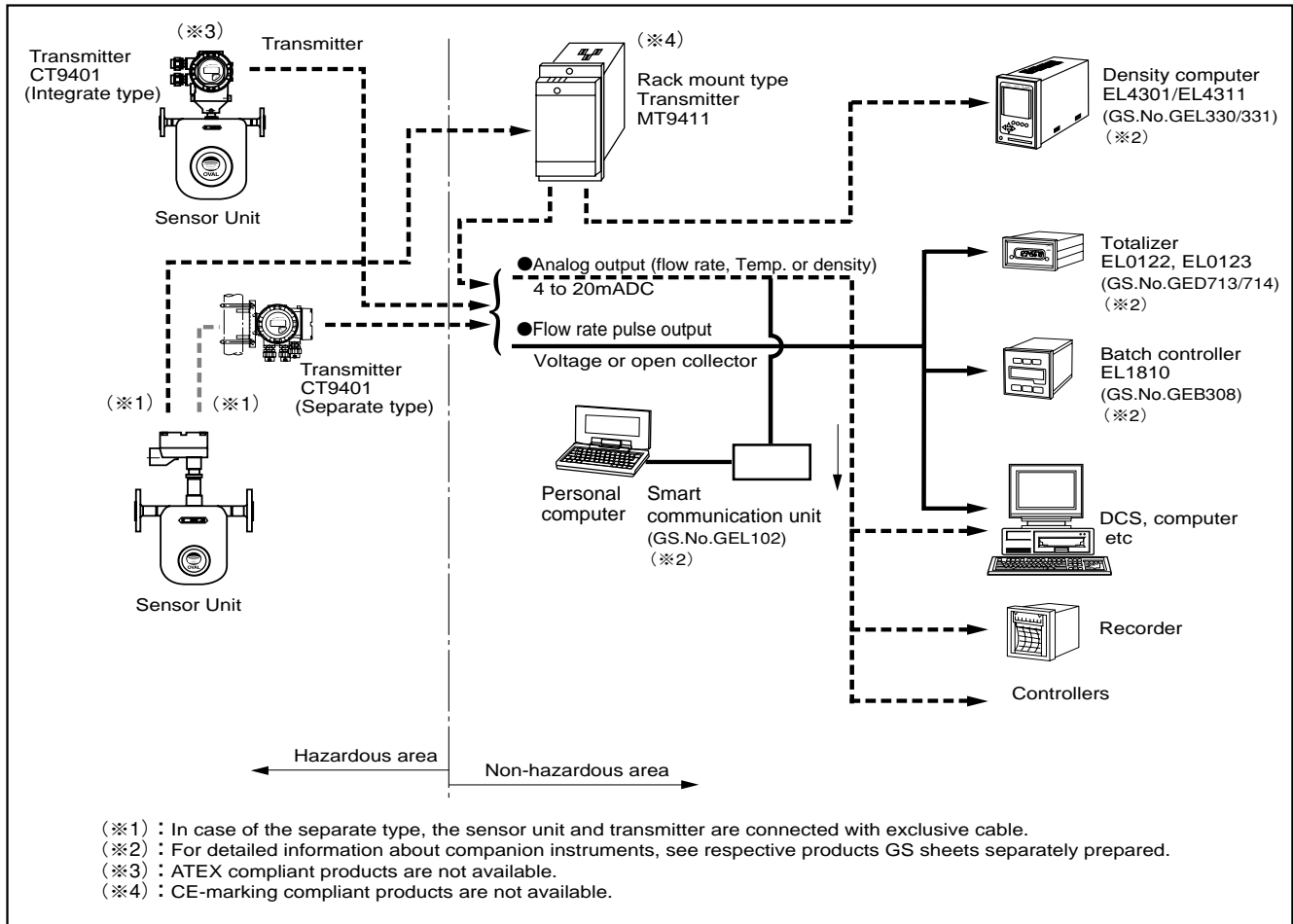

■ WIRING for CT9401

• Transmitter integrate type

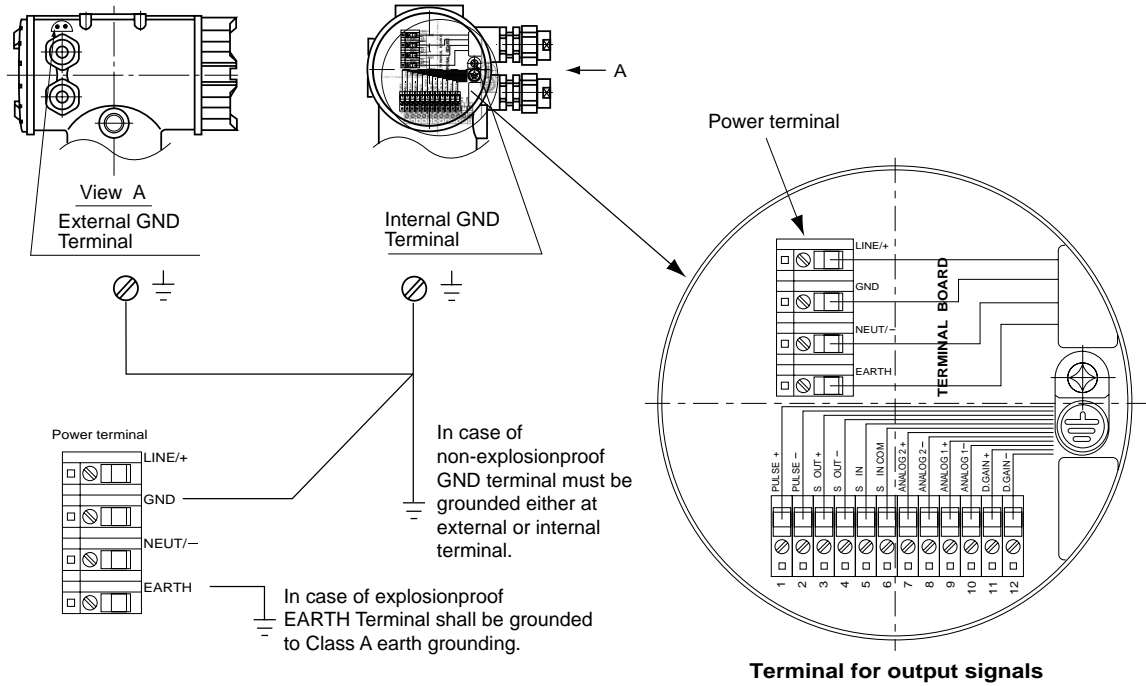

• Remote output signal connection terminals

Item	Terminal No.	Label	Description	Remarks		
Output signal	1	PULSE +	Pulse output	1. Use shielded twisted pairs AWG24-16 for output wiring. 2. Max. load resistance is 600Ω for analog output 1 and 2. 3. Pulse output (voltage pulse) transmission length is Max. 10m (at 10kHz) Max. 100m (at 1kHz) Max. 1km (at 100Hz)		
	2	PULSE -				
	3	S OUT +	Status output, Open collector output			
	4	S OUT -	Normal: ON; Abnormal: OFF			
	5	S IN	Status input (Form "a" contact input)			
	6	S IN COM				
	7	ANALOG2+	Analog output 2			
	8	ANALOG2-				
	9	ANALOG1+	Analog output 1			
	10	ANALOG1-				
	Power		LINE/+		Power (with DC power: +)	Be sure to earth ground at GND or EARTH terminal.
			GND		Earth ground	
		NEUT/-	Power (with DC power: -)			
		EARTH	Class "A" earth ground work			

• Terminal identification between separate type sensor unit and transmitter

Item	Terminal No. (Cable color)	Label	Description	Remarks
Sensor to transmitter	Black	SHIELD	Bundle BWN/RED, GRN/WHY, BLU/GRY, ORG/PUR/YEL shield wires.	Exclusive cable shall be used. Transmission length 200 meters max.
	Brown	(+) DRIVE	Flow tube drive output	
	Red	(-) DRIVE		
	Orange	TEMP B	Temperature input	
	Yellow	TEMP b	Temperature input	
	Green	(+) LPO	Left position pickoff input	
	Blue	(+) RPO	Right position pickoff input	
	Purple	TEMP A	Temperature input	
	Grey	(-) RPO	Left position pickoff input	
	White	(-) LPO	Right position pickoff input	

■ WIRING FOR CT9401

• Transmitter separate type

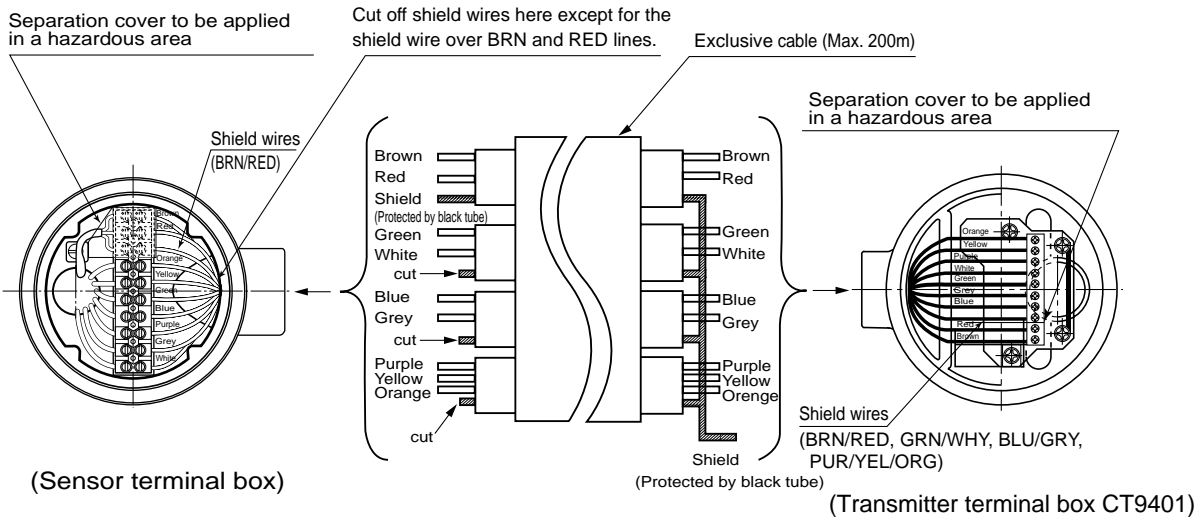
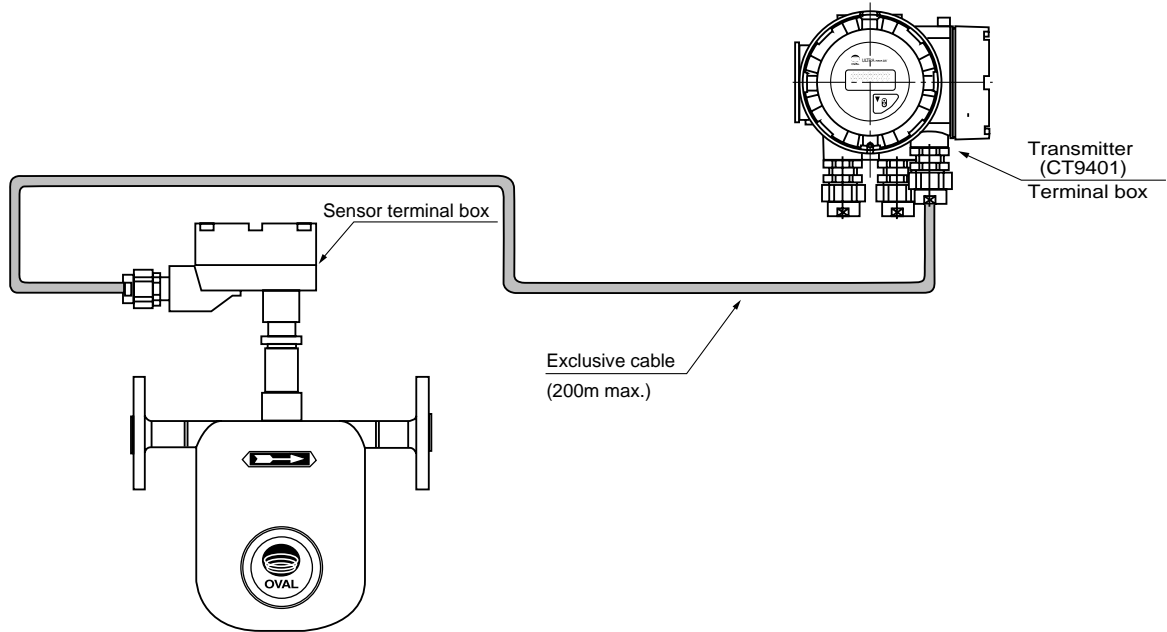

NOTE 1. Do not fail to use exclusive cable.

2. Shield wire preparation

(1) Transmitter end:

Bundle the shield wires corresponding with brown/red, green/white, blue/grey, purple/orange/yellow and slip a black sleeve over them as shown in the figure, exercising care to avoid potential contact with the housing and other conductive parts.

(2) Sensor end:

Slip a black sleeve over the shield wires corresponding with brown/red pair cable as shown in the figure, exercising care to avoid potential contact with the housing and other conductive parts. Clip all other shield wires.

How to install the cover. After wiring with the terminals, install the cover as shown below.

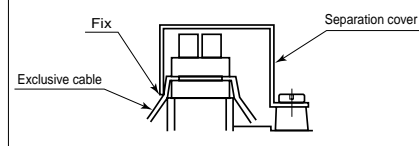

■ TERMINAL IDENTIFICATION

MT9411						
Intrinsically safe side						
1 BRN	DRIVE SIG.	3 ORN	TEMP. B	5 GRN	L.P.O (+)	8 GRA R.P.O (-)
2 RED	DRIVE 0V	4 YEL	SHIELD TEMP.b	6 BLU	R.P.O (+)	9 WHT L.P.O (-)
E	EARTH	0 BLK	SHIELD	7 VIO	TEMP. A	10
Non-intrinsically safe side						
1	PERIOD	5	+ ANALOG 1	9	+ ANALOG 2	13 + STIN
2	N.C.	6	-	10	-	14 -
3	COM.	7	+ PULSE	11	+VF	15
4	D.GAIN	8	-	12	CONTROL	16
Power Supply						
L1 (+)		GND			L2 (-)	

Item	Terminal No.	Label	Description	Cable color sensor body
Intrinsically safe side	1	DRIVE SIG.	Flow tube drive output	BRN
	2	DRIVE 0V		RED
	E	EARTH	Grade A or Grade D grounding *	
	3	TEMP B	Temperature input	ORG
	4	SHIELD TEMP.b	Common	YEL
	0	SHIELD	Shield	BLK
	5	L.P.O (+)	L.H. pos. pickoff sensor input (+)	GRN
	6	R.P.O (+)	R.H. pos. pickoff sensor input(+)	BLU
	7	TEMP A	Temperature input A	PUR
	8	R.P.O (-)	R.H. pos. pickoff sensor input (-)	GRY
9	L.P.O (-)	L.H. pos. pickoff sensor input (-)	WHT	
Non-intrinsically safe side	1	PERIOD	Tube frequency output	
	2	N.C.		
	3	COM.	Common	
	4	D.GAIN	Drive voltage	
	5	+ ANALOG OUT 1	Analogue output 1	
	6	-		
	7	+ PULSE	Pulse output: Voltage pulse or open collector output	
	8	-		
	9	+ ANALOG OUT 2	Analogue output 2	
	10	-		
11	+ STATUS OUT	Error output, flow direction, zeroing output, Hi/Low alarm output		
12	-			
13	+ STATUS IN	Remote zero input (Form "a" contact input) or (Optional feature) OFF in default setting		
14	-			
15				
16				
Power	L1	+ POWER	Power source	
	L2	- POWER		
	G	GND	Connected to the shield wire of output wiring	

*: Explosionproof model requires Grade "A" grounding; non-explosionproof model requires Grade "D" grounding.

■ STANDARD INSTALLATION

1. Typical Installation (See figure at right.)

- 1) Avoid pipeline stresses on the ULTRAss MKII.
- 2) The ULTRAss MKII should be supported near and between connections to the process pipelines.
- 3) Avoid supporting the ULTRAss MKII body directly.
- 4) Pipeline should be arranged such that the ULTRAss MKII is constantly filled with the process fluid. Avoid, however, to install it in a pocket where slurries may build up.
- 5) Provide a valve downstream of the meter to allow zeroing by obtaining a true zero flow. We recommend to provide another valve upstream of the meter for servicing or maintenance.

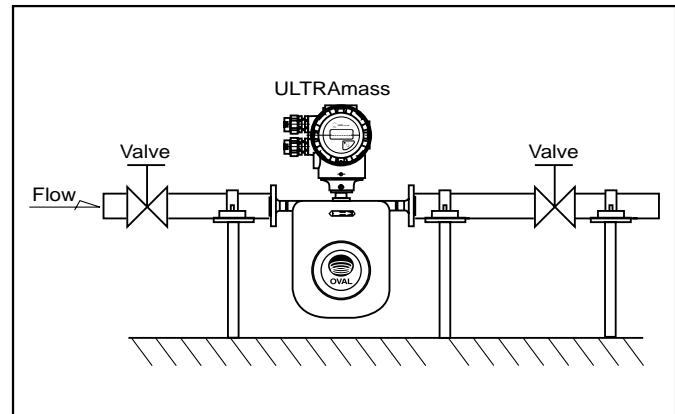

2. Precautions at Installation

- 1) Locate the ULTRAss MKII at least one meter from large transformers, motors, or other sources of electromagnetic induction. Also avoid installation near the sources of excessive vibration, such as motors and pumps.
- 2) If it is desired to make a measurement of a process fluid requiring heat retention, heat trace may be applied directly to the sensor body. Heat trace should be held below 200°C. Explosionproof models require the temperature to be held below their maximum allowable levels.
- 3) In density measurement, heat retention is suggested for stability of readings.
- 4) The sensor unit is of gastight construction. To prevent dew condensation inside in a low temperature application, it is filled with argon gas. For this reason, avoid dropping or giving it impact shocks.
- 5) In a horizontal run, install the sensor unit with the transmitter up as shown in the figure.
- 6) A control valve should be located downstream of the ULTRAss MK II. In an arrangement where cavitation may possibly take place, locate it at least 5 meters away.

- 7) To ensure consistent and accurate measurement, the Coriolis flowmeter should be placed in an environment where pipeline oscillation is held below 0.3G.

3. Prevention of Cavitation

Cavitation can cause a loss of meter accuracy in measurement. Maintain line pressure that will not cause cavitation upstream and downstream of the meter for this reason. Avoid making such an arrangement as to open the line to the atmosphere immediately downstream of the meter.

$$P_d = 3\Delta P + 1.3P_v \text{ (MPa[absolute])}$$

P_d : Downstream pressure (MPa[absolute])

ΔP : Pressure loss across the meter (MPa)

P_v : Steam pressure of the process fluid at measurement (MPa[absolute])

4. Physical orientation

Recommended physical orientation varies with the type of process fluid. No. 2 in the figure below shows the representative orientation for liquid service.

		Horizontal run		Vertical run
No.	1	2	3	
Orientation				
Fluids	<ul style="list-style-type: none"> ● Gases ● Slurries 	<ul style="list-style-type: none"> ● Liquids 	<ul style="list-style-type: none"> ● Slurries (requiring cleaning) ● Liquids ● Gases 	

※ : Do not forget to specify the physical orientation when you order.

■ PRODUCT CODE EXPLANATION

● Sensor unit

Item	Code No.												Description
	①	②	③	④	⑤	⑥	⑦	⑧	⑨	⑩	⑪	⑫	
Model	C	N											ULTRA mass MK II
Nominal size			0	0	3								10mm (3/8") 1/2" In case of ANSI or JPI (Transmitter separate type only)
			0	0	6								10mm (3/8") 1/2" In case of ANSI or JPI
			0	1	0								15mm (1/2")
			0	1	5								15mm (1/2")
			0	2	5								25mm (1")
			0	5	0								40mm (1 1/2"), 50mm (2")
			0	8	0								80mm (3")
Construction			C										CN003 to CN025, CN080
			A										CN050 (40mm)
			B										CN050 (50mm)
			D										CN003 to CN025, CN080 (high temp. service)
			E										CN050 (40mm) (high temp. service)
			F										CN050 (50mm) (high temp. service)
Material						S	S						SUS316L
						S	H						SUS316L+Alley C (Tube only)
						H	Y						Alley C (Applied to CN003 screw connection, CN006 to CN080 flange connection)
Connection type									2				Screw connection (CN003 thru CN015 only)
									3				Flange connection
									4				Ferrule connection (Material "SS" or "SH" only)
													Other than flanged connection
Connection standard									0				JIS
									1				ANSI
									2				JPI
									3				IDF ferrule
									4				Other than flanged connection
Pressure rating									0				10K
									1				20K, ANSI 150, JPI 150
									2				30K, ANSI 300, JPI 300
									3				40K
									4				63K, ANSI 600, JPI 600
									6				
Transmitter Mounting Construction												K	Integrate type CT9401 (Temperature range Max.120°C)
												R	CT9401(Separately-mounted type) or MT9411(rack-mount transmitter)

(※1) : Structural codes C, A, and B apply to fluid and atmospheric temperatures below 130°C.

(※2) : Structural codes D, E, and F (high temp. service) apply to fluid and atmospheric temperatures above 130°C.

● Local mount transmitter (CT9401)

Item	Code No.												Description
	①	②	③	④	⑤	⑥	⑦	⑧	⑨	⑩	⑪	⑫	
Model	C	T	9	4	0	1							Local mount transmitter (CT9401)
Construction												K	Integrate type
												R	Separate type
Power supply									6				20 to 30VDC
									7				85 to 264VAC 50/60Hz
Analog output (※1)								M	M				Mass flow rate Analog 2 output
								M	D				Mass flow + Density
								M	T				Mass flow + Temperature
								M	V				Mass flow + Volume flow
								D	T				Density + Temperature
								V	D				Volume flow + Density
								V	T				Volume flow + Temperature
								M	X				Mass flow rate 1 output (Voltage pulse output)
								D	X				Density 1 output (Voltage pulse output)
Pulse output								V	X				Volume flow 1 output (Voltage pulse output)
									1				Mass flow voltage pulse (option)
									2				Volume flow voltage pulse (option)
									3				Mass flow open collector pulse
Explosion-proof									4				Volume flow open collector pulse
									0				Non-explosionproof
									1				TIIS (domestic explosionproof) (Temp. grade T3)
									2				ATEX (EN50021:1999) (※2)
									3				TIIS (domestic explosionproof) (Temp. grade T4) (※3)
								8				TIIS (domestic explosionproof) (Temp. grade:Sensor T2, Transmitter T4) (※4)	

(※1) : If voltage pulse output is chosen for pulse output, the analog output 2 is not available; select "X" in model code place (10).

(※2) : ATEX compliant products are available only for separately mounted type.

(※3) : Explosionproof temperature class T4 applies only to CN003 separately mounted type and CN006 thru CN080 integrally mounted type.

(※4) : "8" in the ⑫ applies to high pressure service only (except for CN003). And this explosionproof structure is a system approved for explosionproof rating.

※ : "0" to "3" character of the product code ⑫ applies to CN003 for high pressure service. And this explosionproof structure is a system approved for explosionproof rating.

● Rack-mount transmitter (MT9411)

Item	Code No.						Supplemental Code						Description
	①	②	③	④	⑤	⑥	⑦	⑧	⑨	⑩	⑪	⑫	
Model	M	T	9	4	1	1	-						Rack-mount Transmitter
Power Source							6						20 to 30V DC
							7						85 to 250VAC 50Hz/60Hz
Analog Output							M	M					2 mass flow outputs (same for single output)
							M	D					Mass flow + density
							M	T					Mass flow + temperature
							M	V					Mass flow + volume flow
							D	T					Density + temperature
							V	D					Volume flow + density
							V	T					Volume flow + temperature
Pulse Output										1			Mass flow voltage pulse
										2			Volume flow voltage pulse
										3			Mass flow open collector pulse
										4			Volume flow open collector pulse
Status Output										1			Error output
										2			Flow direction
										3			Auto zero in progress
										4			Hi/Low alarm
Explosionproof										0			Non-explosionproof
										1			TIIS (domestic explosionproof) Temperature Class T3
										8			TIIS (domestic explosionproof) Temperature Class T2 (※1)

(※1): “8” in the ⑫ applies to high pressure service only (except for CN003). And this explosionproof structure is a system approved for explosionproof rating.

※: “0” or “1” character of the product code ⑫ applies to CN003 for high pressure service. And this explosionproof structure is a system approved for explosionproof rating.

※: Sensor units rated T4 in temperature class are not compatible with MT9411.

■ PLEASE SUPPLY THE FOLLOWING INFORMATION WHEN YOU INQUIRE

(Fill in the form below to the extent possible. Further details will be finalized in later consultation.)

• Fill in the blanks. Tick the boxes that apply.

1. Sensor unit	CN□□□□-□□-□□□□
2. Transmitter	CT9401-□□□□□□ or MT9411-□□□□□□
3. Process fluid (※1)	Name :_____ SP. gr :_____ Viscosity :_____ Slurry content in a slug flow :_____%
4. Flow range	Max. _____ Normal _____ Full scale _____ <input type="checkbox"/> kg/min <input type="checkbox"/> kg/h <input type="checkbox"/> Others _____
5. Fluid temperature	Max. _____ °C Normal _____ °C Min. _____ °C
6. Operating pressure	Max. _____ MPa Normal _____ MPa Min. _____ MPa
7. Ambient temperature	Max. _____ °C Min. _____ °C
8. Fluid flow direction	<input type="checkbox"/> Left→Right <input type="checkbox"/> Right→Left <input type="checkbox"/> Bottom→Top(<input type="checkbox"/> Top →Bottom) Orientation : See sketch on page 12.
9. Nominal size	_____ mm or _____ inch
10. Required accuracy	± _____ % of reading ± _____ % of full scale
11. Process connection	<input type="checkbox"/> Flanged connection (Flange rating) <input type="checkbox"/> Ferrule connection <input type="checkbox"/> Screw connection
12. CE marking	<input type="checkbox"/> Not required <input type="checkbox"/> Required (※3)
13. Explosionproof	<input type="checkbox"/> Not required <input type="checkbox"/> TIIS <input type="checkbox"/> ATEX
14. Power supply	<input type="checkbox"/> 20 to 30VAC <input type="checkbox"/> 85 to 264VAC (50/60Hz)
15. Output specifications	Pulse output <input type="checkbox"/> Volt. pulse: [0]: 1.5V [1]: 15VDC min. Out. impedance: 2.2kΩ
	<input type="checkbox"/> Open collector: Min. 10V to Max. 30VDC, 50mA
	<input type="checkbox"/> Output frequency: Any point from 0.1 to 10000Hz at full scale
	Analog output 4 to 20mA DC Max. load: 600Ω
	2 outputs from instant. flow rate (mass, volume), temp. or density (option)
Additional damping	0 to 200s. (variable)
Alarm output	Slug flow ^{※2} High _____ g/mL Low _____ g/mL
16. Companion receiver	<input type="checkbox"/> Totalizer <input type="checkbox"/> Indicator <input type="checkbox"/> Recorder <input type="checkbox"/> Flow controller <input type="checkbox"/> Batch controller
	<input type="checkbox"/> Density computer (※4) <input type="checkbox"/> Computer <input type="checkbox"/> Others
17. Transmission length	Sensor unit (<input type="text"/>) m Transmitter (<input type="text"/>) m Receiving instrument
18. Exclusive cable length	In case of separately- mounted type _____ m (Max. 200m)
19. In case of a separated type transmitter	<input type="checkbox"/> Stanchion type w/bracket and 2" U bolts
20. In case of ATEX Cable gland (※2)	<input type="checkbox"/> Not required <input type="checkbox"/> Required
PED certificate of conformity (※2,3)	<input type="checkbox"/> Not required <input type="checkbox"/> Third-party agency <input type="checkbox"/> Generated by OVAL
21. No. of units required	
22. Application	
23. Other considerations	

※1. Special fluids, such as slurries, should be stated precisely and in detail.

※2. Option

※3. In determining compliance with the PED, items 2, 3, 4, 5, 7, and 8 are essential. Describe them as precisely as possible. In certain cases, categorizing may possibly reveal failure to comply.

※4. Compatible only with rack-mount transmitter (MT9411).

The specification as of Sep., 2008 is stated in this GS Sheet. Specifications and design are subject to change without notice.

Sales Representative:

GS.No.GBN053E		
初版	改訂	印刷
00.10	08.9	