

CV3000 Alphaplus series

Top-Guided Single-Seated Control Valves

Model AGVB / AGVM

OVERVIEW

The CV 3000 Alphaplus range of Top-guided Single-seat Control Valves features a compact valve body with excellent flow control and minimal pressure loss. Alphaplus valves have large Cv values, high range ability, and accurate flow control performance.

When securely held in place by a top-guided stem with a long stroke, the valve plug is highly resistant against vibration and provides flow shutoff performance that fully satisfies IEC standards.

The valve also features a compact but powerful multi-spring actuator.

Model AGVB/AGVM control valves are especially suitable for process control applications where high reliability and tight flow shutoff are essential.

1. Selection of Alphaplus specifications

Selection of control valves has traditionally required knowledge and experience. However, CV3000 Alphaplus offers you more accurate product specifications, so that you can easily pinpoint the control valve that satisfies fluid specifications (such as flowrate, pressure, and temperature) at your plant and provides the functions that you need.

To start your process of selecting specifications, open the Model Selection on page 26 and 29, and follow the instructions on the selection map in Figure 1.

If you do not find a valve that completely satisfies your requirements, contact your Yamatake representative for assistance.

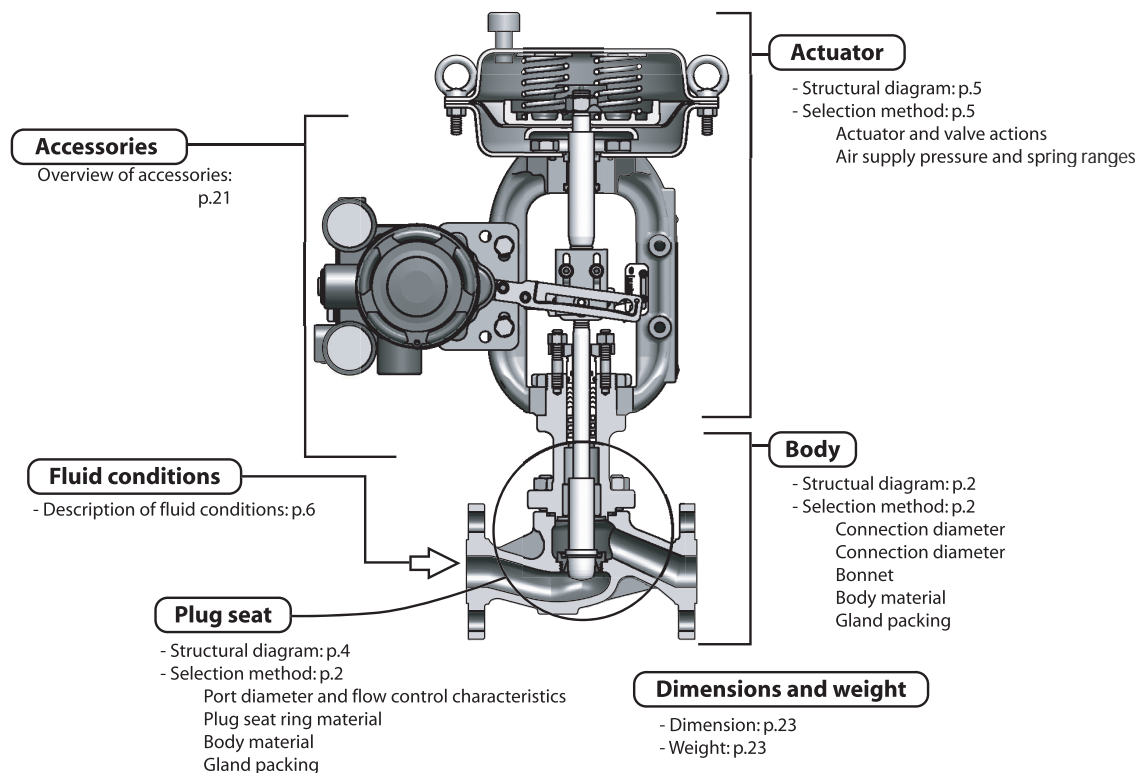

Figure 1 CV3000 Alphaplus selection map

2. Basic model numbers

Basic model: 1/2 to 4 inches

Model AGVB: JIS 10K, ANSI 150, JPI 150

Model AGVM: JIS 16K, JIS 20K, JIS 30K, ANSI 300, JPI 300

3. Optional specifications

3-1 Body

Figure 2 shows optional specifications of the body.

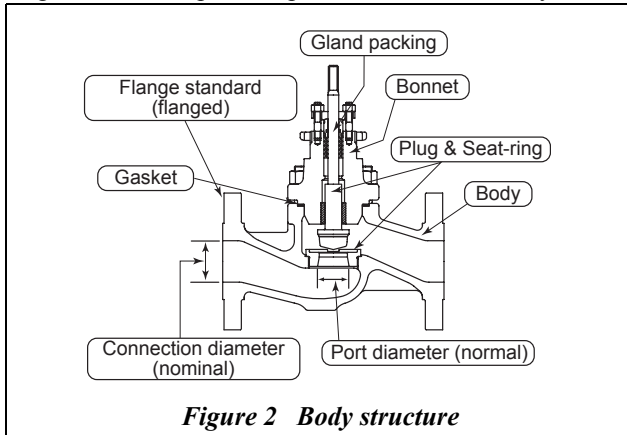

Figure 2 Body structure

3-1-1 Nominal size

Yamatake manufactures diameters from 1/2 inch (15 mm) to 4 inches (100 mm) as shown in Table 6.

For other diameters, we recommend a selection from the CV3000 series of control valves.

3-1-2 Port size and flow control characteristics

The selection of the port size and the rated Cv value falls within the scope of Table 1 according to the Nominal size. For nominal sizes 1 inch (25 mm) or less, port sizes are expressed in terms of Cv values. Flow control characteristics depend on the rated Cv value, be set to linear model or equal percentage model.

Based on the rated Cv value and the calculated necessary Cv value, check the controllability (valve position) using the flow control characteristics Tables in Figure 4, 5, and 6.

3-1-3 Pressure rating and end connection (flange type)

We manufacture

RF:

JIS 10K, 16K, 20K, 30K (JIS B2210-1984)

ANSI 150, 300 (ASME/ANSI B16.5-1988)

JPI 150, 300 (JPI-7S-15-1993)

Option: Socket weld, butt weld

For other rated pressures and connection types, you are recommended to consider the CV 3000 series of control valves.

3-1-4 Bonnet style

We manufacture bonnets that can be used at fluid temperatures ranging from -196°C to 400°C.

Table 1

[Unit: °C]

Bonnet \ Body material	SCPH 2	SCS13A/SCS14A
Plain	-5 to +230	-17 to +230
Extension type I (High•Low temperature)	+230 to +400	-45 to -17 +230 to +400
Extension type II (Liquid O2•N2)	-	-196 to -45

For fluid temperatures outside the above temperature range, we recommend a selection from the CV3000 series of control valves.

3-1-5 Body, plug and seat ring materials

For combinations of body, plug and seat ring materials and their applicable temperature ranges, see Table 7. In some ranges the plug seat ring material needs hardening treatment. See Figure 9. When you select a soft seat, refer to Figure 10.

For materials other than those shown in Table 7, we recommend a selection from the CV3000 series of control valves, or other Yamatake series of control valves.

3-1-6 Valve seat leakage

For the seat leak performance when the valve is fully closed, select from among the following four classifications, which conform to IEC 60534-4:1999 and JIS B 2005-4:2008 :

Class IV: $10^{-4} \times$ rated Cv value
(0.01% of rated Cv value)

Class IV-S1: $5 \times 10^{-6} \times$ rated Cv value
(0.0005% of rated Cv value)

Class V: $1.8 \times 10^{-4} \times$ Valve differential pressure (MPa)
 \times Port size (mm) l/h

Class VI: $3 \times$ valve differential pressure (MPa)
 \times leakage coefficient ml/min. shown below

Table 2 Leakage coefficient value

Nominal size inches (mm)	1 (25)	1¼ (32)	1½ (40)	2 (50)	2½ (65)	3 (80)	4 (100)
Leakage coefficient	0.15	0.17	0.23	0.36	0.51	0.62	1.20

For shutoff valves, choose either Class V or VI. To maintain over time the performance of Class V or Class IV-S1 valves, the plug seat material requires hardening treatment. Class IV valves, seat type is soft seat (PTFE). Additionally with the selection of the low-temperature service, oil-proof, water-proof service for the choice of material seat, the set leakage is Class IV-S1.

3-1-7 Inherent range ability:

Table 3 Inherent range ability Vs rated Cv value

Rated Cv	Inherent Range ability
0.1, 0.16, 0.25, 0.4	20:1
0.63	30:1
1.0 or more than 1.0	50:1(75:1*)

*:Optional, metal seat and equal percentage only.

3-1-8 Gland packing

According to your application, select appropriate type of gland packing from among the following:

Table 4 Selection of gland packing

Usage	Type	Material
General use (oils, solvent acids, alkalis, etc.)	PTFE yarn packing (NP4519)	Woven PTFE yarn with carbon fiber core
Waste oil washing	V type PTFE packing	PTFE molding
Vacuum service	V type PTFE packing (direct + reverse) mounted	PTFE molding
Low-temperature service	V type PTFE packing	PTFE molding
High-temperature service	Graphite yarn packing * (P6610CL+P6722)	Graphite

Note) PTFE: polytetrafluoroethylene resin

* Grease provided

For other gland packing materials, please provide closest model No. and Yamatake will take your request under advice.

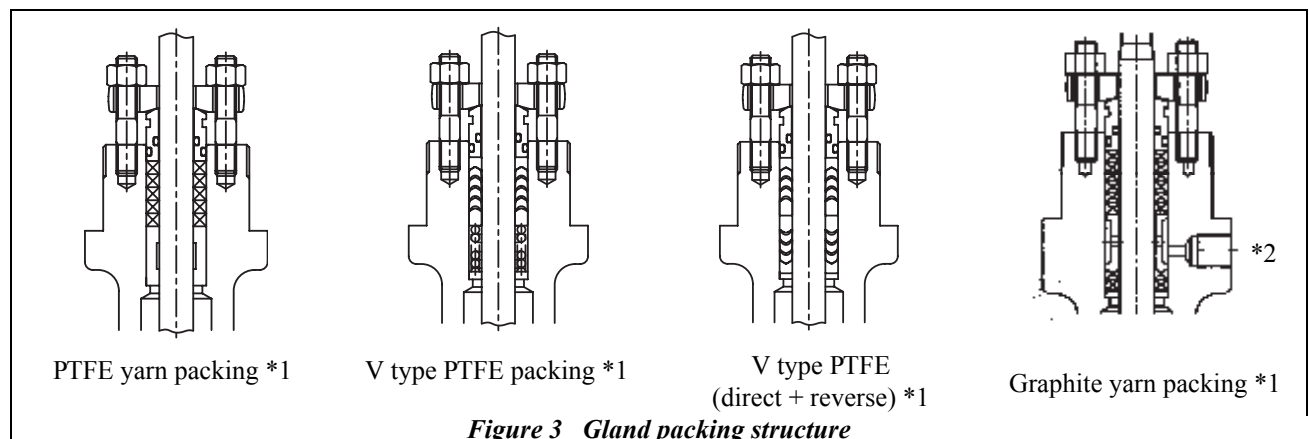

Note) *1: It is a standard practice to use packing glands with O-rings to render them dustproof.

*2 Grease provided by lubricator

3-1-9 Gasket

Table 5 Selection of gasket

	Super-low temperature / Oil-free (Liquid O ₂ •N ₂)	General / Low temp.	High temperature	Oil-free treatment
Between bonnet and body	Spiral-shaped gasket Hoop material: SUS316 Filler material: PTFE	Metal gasket (PTFE coating) V543(PTFE)	Metal gasketV543	Metal gasket (PTFE coating) V543 (PTFE)
Between seat ring and body	Metal gasket	Not necessary	Metal gasketV564 (Monel)	Metal gasket (PTFE coating) V563 (PTFE)

Table 6 Models of AGVB and AGVM

Nominal size inches (mm)	1 (25)						1½ (40)			2(50)			2½(65)			3(80)			4(100)		
	¾ (20)																				
	½ (15)																				
Port size (inches)	0.1	0.4	1.0	2.5	8.0	10	1	1¼	1½	1¼	1½	2	1½	2	2½	2	2½	3	2½	3	4
Rated Cv value	0.16	0.63	1.6	4.0	6.3	14	14	21	30	21	30	50	30	50	85	50	85	115	85	115	200
Rated travel (mm)	20						20			20			38			38			38		
Flow characteristics	Fig.4		Fig. 5										Fig. 6, 7								

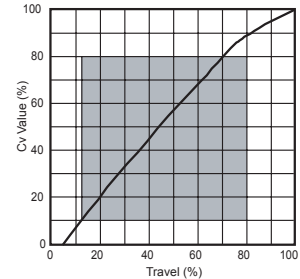
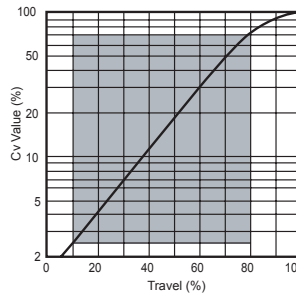
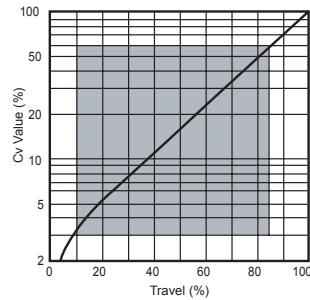
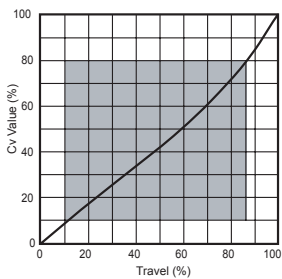

Figure 4 Cv values 0.1, 0.16, and 0.25 (linear model)

Figure 5 Cv values 0.4 to 14 (equal percentage model)

Figure 6 Port size 1½ to 4 inches (equal percentage model)

Figure 7 Cv values 0.4 to 14, Port size 1½ to 4 inches (linear model)

Scope of control generally considered feasible. (*Cv value in percentage and travel in percentage.)

*2 Grease provided by lubricator

Table 7 Body, plug and seat ring material

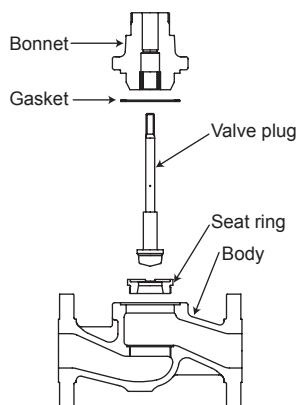

Material combination	Temperature ranges (°C)			
SUS 316	-5 to +300	-45 to +300	-45 to +300	
SUS 316 stellite	-5 to +400	-196 to +400	-196 to +400	
SUS440C	-5 to +400	-45 to +400	---	
SUS 316 soft seat	-5 to +230	-45 to +230	-45 to +230	
SUS 316 full-surface stellite	-5 to +400	-196 to +400	-196 to +400	
SUS 316L	---	-45 to +300	-45 to +300	
SUS 316L stellite	---	-196 to +400	-196 to +400	
Body material	JIS	SCPH2	SCS13A	SCS14A
	ASTM	A216WCB	A351CF8	A351CF8M

Note) *1: Parts that adjust flow (such as a plug and a seat ring) are referred to as the valve trim.

Figure 8 Explosion view of AGVB/AGVM

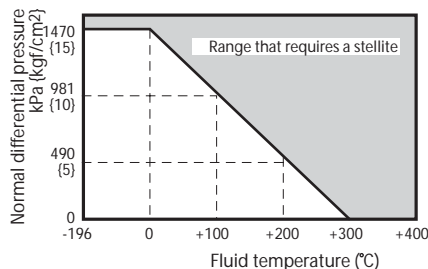

Figure 9 Temperature and normal differential pressure ranges requiring a stellite

Note) 1) Depending on the methods of hardening treatment, stellite welding or SUS440C is available.
 2) For valves for cavitation/flashing service, oil-proof service, or tight shutoff service, a stellite is recommended regardless of process fluid temperatures or differential pressures.
 3) For valves for cavitation/flashing service for water or for valves for superheated water above 100 °C, SUS 440C is recommended.

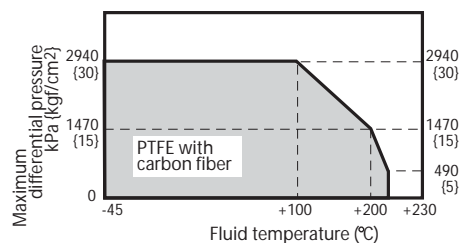

Figure 10 Temperature and maximum differential pressure ranges for soft seat

Note) 1) When there is a possibility of erosion by such fluids as saturated steam and heated water please use metal seats.
 2) With the fluid connecting parts (inside the body) the material of the seat which oil-proof washing treatment had been completed is PTFE entered with glass.

3-2 Actuator

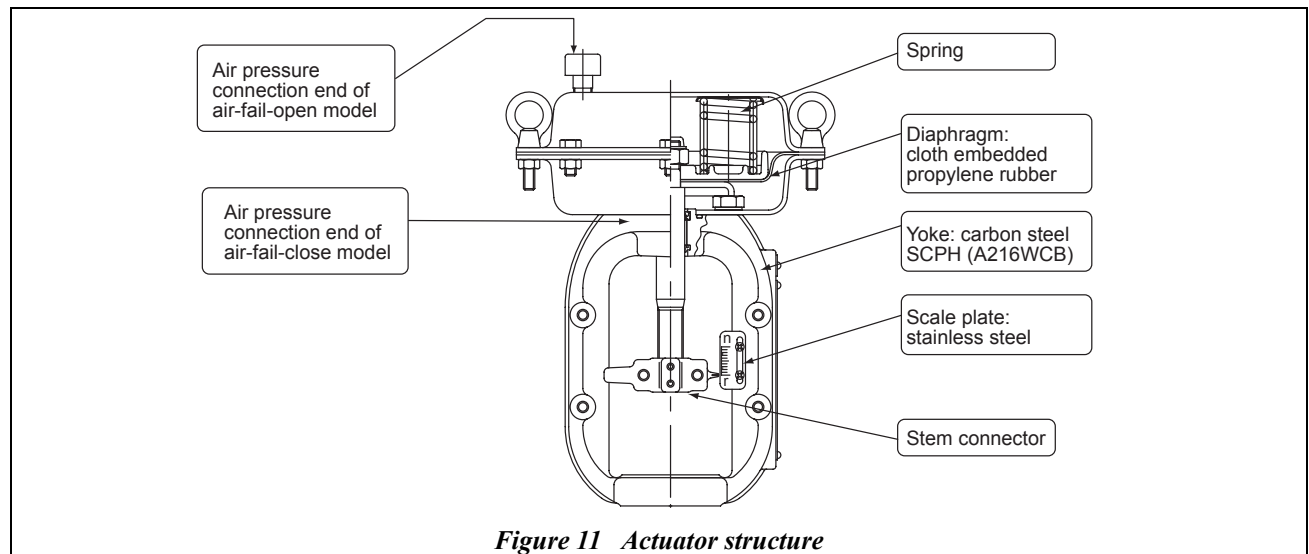

Figure 11 Actuator structure

3-2-1 Actuator and valve actions

Selection of actuator actions determines valve actions (in response to input signals).

Air-to-open: actuator action where the valve opens as the input signal increases

Air-to-close: actuator action where the valve closes as the input signal increases

With the Alphaplus, the valve closes as the plug lowers. The valve action depends, in turn, on whether an air-to-open or air-to-close actuator is chosen. The material of bolt and nut are SUS304.

3-2-2 Tables of allowable differential pressures

Ensure the required shutoff differential pressure specified in the equipment design is satisfied by selecting an actuator with an allowable differential pressure equal to or higher than the shutoff pressure, according to the seat leakage class.

Leakage, specification Class IV (0.01% of rated Cv value)

- Model AGVB

Air-to-open: Table 9 and 10

Air-to-close: Table 11 and 12

- Model AGVM

Air-to-open: Table 13 and 14

Air-to-close: Table 15 and 16

Leakage, specification Class V (high shutoff model: metal seat) or Class IV-S1 (0.0005% of rated Cv value)

- Model AGVB

Air-to-open: Table 17 and 18

Air-to-close: Table 19 and 20

- Model AGVM

Air-to-open: Table 21 and 22

Air-to-close: Table 23 and 24

Leakage, specification Class VI (high shutoff model: soft seat)

- Model AGVB

Air-to-open: Table 25 and 26

Air-to-close: Table 27 and 28

- Model AGVM

Air-to-open: Table 29 and 30

Air-to-close: Table 31 and 32

At your request, we can manufacture control valves with normal pressures exceeding 1.96 MPa.

3-2-3 Supply pressure and spring ranges

Select the actuator using the table of allowable differential pressures. The table also assists in determining the actuator's required supply pressure and required spring range.

If the applicable value in the table of allowable differential pressures is not large enough for the shutoff pressure you need, we will, at your request, consider a larger actuator size.

3-2-4 Performance (with positioner)

Actuator		PSA1	PSA2 to 4	PSA6
Linearity	VPE	±3	-	-
	AVP	±2	±1	±2
	HEP			
	HTP			
Hysteresis error		1	1	2

3-2-5 Finish

The normal standard coating color for Yamatake control valves is blue (Munsell color 10B 5/10). Silver is also available as standard.

You can specify any other color using the number code of the Japan Paint Industry Assignment or the Munsell color system.

Standard colors are also used for such optional accessories as positioners, pressure regulator with filter, and solenoid valves.

4. Fluid conditions

Please clear the fluid conditions as follows

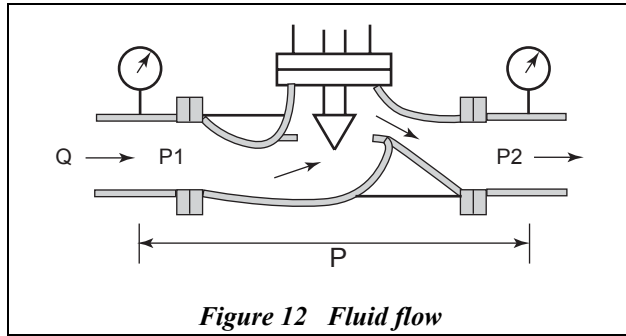

Figure 12 Fluid flow

Table 8 Fluid condition

Mark	Name	Description
-	Fluid name	Name or symbol of fluid to flow through control valve
Q	Flow rate	Maximum (MAX), normal (NOR), and minimum (MIN) flow rates to be controlled
P1	Upstream pressure	Pressure on upstream side of control valve (P1 in Figure 12)
P2	Downstream pressure	Pressure on downstream side of control valve (P2 in Figure 12)
ΔP	Differential pressure	Pressure loss at control valve (ΔP in Figure 12)
ΔP close	Differential pressure when fully closed	Differential pressure when the valve is fully closed (actuator selection condition)
Temp	Temperature	Temperature of fluid on upstream side
G	Specific gravity	Specific gravity of the fluid
V	Viscosity	Viscosity at the temperature of the fluid on upstream side
-	Flashing %	Weight percentage of flashing to occur on downstream side when pressure is reduced by the control valve

Calculation of the Cv values and expected noise

Selection of Cv values: No. IB1-8000-0100

Selection of expected noise: No. IB1-8000-1700

Yamatake has developed personal computer software to calculate Cv values and expected noise.

Please specify if you require such a PC-based tool.

Valve seat leakage, Class IV: 0.01% of the rated Cv value

Table 9 Model AGVB flange nominal size 1/2, 3/4, and 1 inch

Note that the allowable differential pressure varies with the rated Cv value you have selected.

Air-to-open

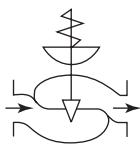

Nominal size inches	Actuator	Supply pressure kPa {kgf/cm ² }	Spring range kPa {kgf/cm ² }	Differential pressure (by Cv value) kPa {kgf/cm ² }					
				0.1 0.16 0.25	0.4 0.63	1.0 1.6	2.5 4.0	6.3 8.0	10 14
1/2	PSA1R	140 {1.4}	20 to 98 {0.2 to 1.0}			1650 {16.8}	1020 {10.4}	550 {5.6}	410 {4.2}
3/4		270 {2.8}	80 to 240 {0.8 to 2.4}			1960 {20.0}			
1	PSA2R	140 {1.4}	20 to 98 {0.2 to 1.0}	--	--			1070 {10.9}	800 {8.2}

- Note) 1. In the case of using positioners, please the setting of supply pressure with pressure regulator.
 2. The maximum allowable differential pressures must not exceed the maximum working pressures specified by JISB2201-1984, ANSIB16.34-1981, and JPI-7S-65-831.

Table 10 Model AGVB nominal size 1½, 2, 2½, 3 and 4 inches

Note that the allowable differential pressure varies with the port size (inches) you have selected.

Air-to-open

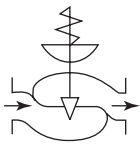

Nominal size inches	Actuator	Supply pressure kPa {kgf/cm ² }	Spring range kPa {kgf/cm ² }	Differential pressure (by port size (inches)) kPa {kgf/cm ² }						
				1	1¼	1½	2	2½	3	4
1½ 2	PSA1R	140 {1.4}	20 to 98 {0.2 to 1.0}	410 {4.2}	250 {2.6}	170 {1.8}	100 {1.1}	--	--	--
		270 {2.8}	80 to 240 {0.8 to 2.4}	1960 {20.0}	1780 {18.2}	1210 {12.3}	720 {7.4}	--	--	--
	PSA2R	140 {1.4}	20 to 98 {0.2 to 1.0}	800 {8.2}	490 {5.0}	330 {3.4}	200 {2.0}	--	--	--
		270 {2.8}	80 to 240 {0.8 to 2.4}	--	1960 {20.0}		1400 {14.3}	--	--	--
	PSA3R	140 {1.4}	20 to 98 {0.2 to 1.0}	1420 {14.5}	880 {8.9}	590 {6.0}	350 {3.6}	--	--	--
		270 {2.8}	80 to 240 {0.8 to 2.4}	--	--	--	1960 {20.0}	--	--	--
PSA4R	140 {2.8}	20 to 98 {0.2 to 1.0}	1960 {20.0}	1510 {15.4}	1030 {10.5}	610 {6.2}	--	--	--	
2½	PSA3R	140 {1.4}	20 to 98 {0.2 to 1.0}	--	--	590 {6.1}	350 {3.6}	220 {2.2}	160 {1.6}	--
		270 {2.8}	80 to 240 {0.8 to 2.4}	--	--	1960 {20.0}		1530 {15.6}	1100 {11.3}	620 {6.3}
3	PSA4R	140 {1.4}	20 to 98 {0.2 to 1.0}	--	--	1030 {10.5}	610 {6.2}	380 {3.9}	270 {2.8}	150 {1.16}
		270 {2.8}	80 to 240 {0.8 to 2.4}	--	--	--	--	1960 {20.0}	1910 {19.4}	1070 {10.9}
4	PSA6R	260 {2.6}	100 to 180 {1.0 to 1.8}	--	--	--	--	--	1960 {20.0}	1450 {14.8}
		400 {4.0}	200 to 340 {2.0 to 3.5}	--	--	--	--	--	--	1960 {20.0}

- Note) 1. In the case of using positioners, please the setting of supply pressure with pressure regulator.
 2. The maximum allowable differential pressures must not exceed the maximum working pressures specified by JISB2201-1984, ANSIB16.34-1981, and JPI-7S-65-831.

Valve seat leakage, Class IV: 0.01% of the rated Cv value

Table 11 Model AGVB nominal size 1/2, 3/4 and 1 inch

Note that the allowable differential pressure varies with the rated Cv value you have selected.

Air-to-close

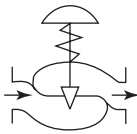

Nominal size inch	Actuator	Supply pressure kPa {kgf/cm ² }	Spring range kPa {kgf/cm ² }	Differential pressure (by Cv value) kPa {kgf/cm ² }					
				0.1 0.16 0.25	0.4 0.63	1.0 1.6	2.5 4.0	6.3 8.0	10 14
1/2	PSA1D	140 {1.4}	20 to 98 {0.2 to 1.0}					1380 {14.1}	1030 {10.5}
		160 {1.6}	20 to 98 {0.2 to 1.0}	1960 {20.0}				1860 {18.9}	
		390 {4.0}	80 to 240 {0.8 to 2.4}						
1	PSA2D	140 {1.4}	20 to 98 {0.2 to 1.0}	--	--	--	--		
		160 {1.6}	20 to 98 {0.2 to 1.0}	--	--	--	--	--	

- Note) 1. In the case of using positioners, please the setting of supply pressure with pressure regulator.
 2. The maximum allowable differential pressures must not exceed the maximum working pressures specified by JISB2201-1984, ANSIB16.34-1981, and JPI-7S-65-831.

Table 12 Model AGVB nominal size 1½, 2, 2½, 3 and 4 inches

Note that the allowable differential pressure varies with the port size (inches) you have selected.

Air-to-close

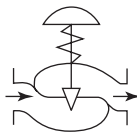

Nominal size inches	Actuator	Supply pressure kPa {kgf/cm ² }	Spring range kPa {kgf/cm ² }	Differential pressure (by port size (inches)) kPa {kgf/cm ² }						
				1	1¼	1½	2	2½	3	4
1½ 2	PSA1D	140 {1.4}	20 to 98 {0.2 to 1.0}	1030 {10.5}	640 {6.5}	430 {4.4}	260 {2.6}	--	--	--
		160 {1.6}	20 to 98 {0.2 to 1.0}	1860 {18.9}	1150 {11.7}	780 {7.9}	460 {4.7}	--	--	--
		390 {4.0}	80 to 240 {0.8 to 2.4}					1500 {15.3}	--	--
	PSA2D	140 {1.4}	20 to 98 {0.2 to 1.0}	1960 {20.0}	1230 {12.6}	840 {8.5}	500 {5.1}	--	--	--
		160 {1.6}	20 to 98 {0.2 to 1.0}					1510 {15.4}	900 {9.2}	--
		390 {4.0}	80 to 240 {0.2 to 1.0}	--	--	--	1960 {20.0}	--	--	--
	PSA3D	140 {1.4}	20 to 98 {0.2 to 1.0}	--	1960 {20.0}	1490 {15.1}	890 {9.0}	--	--	--
		160 {1.6}	20 to 98 {0.2 to 1.0}	--	--	1960 {20.0}	1600 {16.3}	--	--	--
		390 {4.0}	80 to 240 {0.2 to 1.0}	--	--		1530 {15.6}	--	--	--
	PSA4D	140 {1.4}	20 to 98 {0.2 to 1.0}	--	--	--	1960 {20.0}	--	--	--
		160 {1.6}	20 to 98 {0.2 to 1.0}	--	--	--	1960 {20.0}	--	--	--
		390 {4.0}	80 to 240 {0.8 to 2.4}	--	--	--	--	--	--	--
2½ 3 4	PSA3D	140 {1.4}	20 to 98 {0.2 to 1.0}	--	--	1490 {15.1}	890 {9.0}	550 {5.6}	390 {4.0}	220 {2.3}
		160 {1.6}	20 to 98 {0.2 to 1.0}	--	--	1960 {20.0}	1600 {16.3}	990 {10.0}	710 {7.2}	400 {4.1}
		390 {4.0}	80 to 240 {0.8 to 2.4}	--	--		1530 {15.6}	950 {9.6}	680 {6.9}	380 {3.9}
	PSA4D	140 {1.4}	20 to 98 {0.2 to 1.0}	--	--	--	1960 {20.0}	1700 {17.4}	1230 {12.5}	700 {7.0}
		160 {1.6}	20 to 98 {0.2 to 1.0}	--	--	--	1960 {20.0}	1700 {17.4}	1230 {12.5}	700 {7.0}
		390 {4.0}	80 to 240 {0.8 to 2.4}	--	--	--	--	--	--	1960 {20.0}

- Note) 1. In the case of using positioners, please the setting of supply pressure with pressure regulator.
 2. The maximum allowable differential pressures must not exceed the maximum working pressures specified by JISB2201-1984, ANSIB16.34-1981, and JPI-7S-65-831.

Valve seat leakage, Class IV: 0.01% of the rated Cv value

Table 13 Model AGVM nominal size 1/2, 3/4 and 1 inch

Note that the allowable differential pressure varies with the rated Cv value you have selected.

Air-to-open

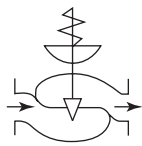

Nominal size (inch)	Actuator	Supply pressure kPa {kgf/cm ² }	Spring range kPa {kgf/cm ² }	Differential pressure (by Cv value) kPa {kgf/cm ² }					
				0.1 0.16 0.25	0.4 0.63	1.0 1.6	2.5 4.0	6.3 8.0	10 14
1/2	PSA1R	140 {1.4}	20 to 98 {0.2 to 1.0}	1960 {20.0}		1650 {16.8}	1020 {10.4}	550 {5.6}	410 {4.2}
				5100 {52.0}	3120 {31.8}				
3/4	PSA1R	270 {2.8}	80 to 240 {0.8 to 2.4}	1960 {20.0}					
				5100 {52.0}				3870 {39.5}	2890 {29.5}
1	PSA2R	140 {1.4}	20 to 98 {0.2 to 1.0}	--	1960 {20.0}			1070 {10.9}	800 {8.2}
					5100 {52.0}	3200 {32.6}	1970 {20.1}		
		270 {2.8}	80 to 240 {0.8 to 2.4}	--	--	--	--	1960 {20.0}	
								5100 {52.0}	

- Note) 1. In the case of using positioners, please the setting of supply pressure with pressure regulator.
 2. The maximum allowable differential pressures must not exceed the maximum working pressures specified by JISB2201-1984, ANSIB16.34-1981, and JPI-7S-65-831.
 3. In the differential pressure column, upper figures show normal differential pressures and lower figures differential pressures when the valve is fully closed.

Valve seat leakage, Class IV: 0.01% of the rated Cv value

Table 14 Model AGVM nominal size 1½, 2, 2½, 3 and 4 inches

Note that the allowable differential pressure varies with the port size (inches) you have selected.

Air-to-open

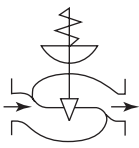

Nominal size (inches)	Actuator	Supply pressure kPa {kgf/cm ² }	Spring range kPa {kgf/cm ² }	Differential pressure (by port size (inches)) kPa {kgf/cm ² }							
				1	1¼	1½	2	2½	3	4	
1½ 2	PSA1R	140 {1.4}	20 to 98 {0.2 to 1.0}	410 {4.2}	250 {2.6}	170 {1.8}	100 {1.1}	--	--	--	
		270 {2.8}	80 to 240 {0.8 to 2.4}	1960 {20.0}	1780 {18.2}	1210 {12.3}	720 {7.4}	--	--	--	
	PSA2R	140 {1.4}	20 to 98 {0.2 to 1.0}	800 {8.2}	490 {5.0}	330 {3.4}	200 {2.0}	--	--	--	
		270 {2.8}	80 to 240 {0.8 to 2.4}	1960 {20.0}			1400 {14.3}	--	--	--	
	PSA3R	140 {1.4}	20 to 98 {0.2 to 1.0}	1420 {14.5}	880 {8.9}	590 {6.1}	350 {3.6}	--	--	--	
		270 {2.8}	80 to 240 {0.8 to 2.4}	--	1960 {20.0}			--	--	--	
	PSA4R	140 {1.4}	20 to 98 {0.2 to 1.0}	1960 {20.0}	1510 {15.4}	1030 {10.5}	610 {6.2}	--	--	--	
		270 {2.8}	80 to 240 {0.8 to 2.4}	--	--	1960 {20.0}		--	--	--	
	2½ 3 4	PSA3R	140 {1.4}	20 to 98 {0.2 to 1.0}	--	--	590 {6.1}	350 {3.6}	220 {2.2}	160 {1.6}	--
			270 {2.8}	80 to 240 {0.8 to 2.4}	--	--	1960 {20.0}		1530 {15.6}	1100 {11.3}	620 {6.3}
		PSA4R	140 {1.4}	20 to 98 {0.2 to 1.0}	--	--	1030 {10.5}	610 {6.2}	380 {3.9}	270 {2.8}	150 {1.6}
			270 {2.8}	80 to 240 {0.8 to 2.4}	--	--	1960 {20.0}			1910 {19.4}	1070 {10.9}
PSA6R		260 {2.6}	100 to 180 {1.0 to 1.8}	--	--	--	1960 {20.0}			1450 {14.8}	
		400 {4.0}	200 to 340 {2.0 to 3.5}	--	--	--	5100 {52.0}	3570 {36.4}	2570 {26.2}		
							1960 {20.0}			3050 {31.1}	

- Note) 1. In the case of using positioners, please the setting of supply pressure with pressure regulator.
 2. The maximum allowable differential pressures must not exceed the maximum working pressures specified by JISB2201-1984, ANSIB16.34-1981, and JPI-7S-65-831.
 3. In the differential pressure column, upper figures show normal differential pressures and lower figures differential pressures when the valve is fully closed.

Valve seat leakage, Class IV: 0.01% of the rated Cv value

Table 15 Model AGVM nominal size 1/2, 3/4 and 1 inch

Note that the allowable differential pressure varies with the rated Cv value you have selected.

Air-to-close

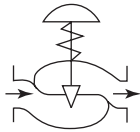

Nominal size (inches)	Actuator	Supply pressure kPa {kgf/cm ² }	Spring range kPa {kgf/cm ² }	Differential pressure (by Cv value) kPa {kgf/cm ² }					
				0.1 0.16 0.25	0.4 0.63	1.0 1.6	2.5 4.0	8.0 6.3	10 14
1/2 3/4 1	PSA1D	140 {1.4}	20 to 98 {0.2 to 1.0}	1960 {20.0}			1380	1030	
				5100 {52.0}	4130 {42.1}	2550 {26.0}	{14.1}	{10.5}	
		160 {1.6}	20 to 98 {0.2 to 1.0}	1960 {20.0}			1860	1860	
			5100 {52.0}	4590 {46.8}	2490 {25.4}	{18.9}			
	390 {4.0}	80 to 240 {0.8 to 2.4}	1960 {20.0}						
			5100 {52.0}						
PSA2D	140 {1.4}	20 to 100 20 to 98 {0.2 to 1.0}	--	--	1960 {20.0}			2000	
					5100 {52.0}	4940 {50.3}	2680 {27.3}	{20.4}	
160 {1.6}	20 to 98 {0.2 to 1.0}	--	--	--	1960 {20.0}			3600	
					5100 {52.0}	4830 {49.2}	3600 {36.7}		

- Note) 1. In the case of using positioners, please the setting of supply pressure with pressure regulator.
 2. The maximum allowable differential pressures must not exceed the maximum working pressures specified by JISB2201-1984, ANSIB16.34-1981, and JPI-7S-65-831.
 3. In the differential pressure column, upper figures show normal differential pressures and lower figures differential pressures when the valve is fully closed.

Valve seat leakage, Class IV: 0.01% of the rated Cv value

Table 16 Model AGVM nominal size 1½, 2, 2½, 3 and 4 inches

Note that the allowable differential pressure varies with the port size (inches) you have selected.

Air-to-close

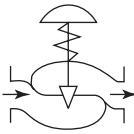

Nominal size (inches)	Actuator	Supply pressure kPa {kgf/cm ² }	Spring range kPa {kgf/cm ² }	Differential pressure (by port size (inches)) kPa {kgf/cm ² }							
				1	1¼	1½	2	2½	3	4	
1½ 2	PSA1D	140 {1.4}	20 to 98 {0.2 to 1.0}	1030 {10.5}	640 {6.5}	430 {4.4}	260 {2.6}	--	--	--	
		160 {1.6}	20 to 98 {0.2 to 1.0}	1860 {18.9}	1150 {11.7}	780 {7.9}	460 {4.7}	--	--	--	
		390 {4.0}	80 to 240 {0.8 to 2.4}	1960 {20.0}			1500 {15.3}	--	--	--	
	PSA2D	140 {1.4}	20 to 98 {0.2 to 1.0}	2000 {20.0}	1230 {12.6}	840 {8.5}	500 {5.1}	--	--	--	
		160 {1.6}	20 to 98 {0.2 to 1.0}	1960 {20.0}		1510 {15.4}	900 {9.2}	--	--	--	
		390 {4.0}	80 to 240 {0.8 to 2.4}	--	1960 {20.0}			2900 {29.6}	--	--	--
	PSA3D	140 {1.4}	20 to 98 {0.2 to 1.0}	1960 {20.0}		1490 {15.1}	890 {9.0}	--	--	--	
		160 {1.6}	20 to 98 {0.2 to 1.0}	5100 {52.0}	3940 {40.2}	2670 {27.3}	1600 {16.3}	--	--	--	
		390 {4.0}	80 to 240 {0.8 to 2.4}	--	--	1960 {20.0}		5100 {52.0}	--	--	--
		140 {1.4}	20 to 98 {0.2 to 1.0}	1960 {20.0}			1530 {15.6}	--	--	--	
		160 {1.6}	20 to 98 {0.2 to 1.0}	--	--	1960 {20.0}		2760 {28.1}	--	--	--
		390 {4.0}	80 to 240 {0.8 to 2.4}	--	--	1960 {20.0}			3180 {32.4}	2290 {23.3}	1290 {13.1}
PSA4D	140 {1.4}	20 to 98 {0.2 to 1.0}	--	--	1960 {20.0}	1530 {15.6}	950 {9.6}	680 {6.9}	380 {3.9}		
	160 {1.6}	20 to 98 {0.2 to 1.0}	--	--	1960 {20.0}		1700 {17.4}	1230 {12.5}	690 {7.0}		
	390 {4.0}	80 to 240 {0.8 to 2.4}	--	--	--	--	1960 {20.0}				
	140 {1.4}	20 to 98 {0.2 to 1.0}	--	--	1960 {20.0}	2570 {26.2}	1530 {15.6}	950 {9.6}	680 {6.9}	380 {3.9}	
	160 {1.6}	20 to 98 {0.2 to 1.0}	--	--	1960 {20.0}		1700 {17.4}	1230 {12.5}	690 {7.0}		
	390 {4.0}	80 to 240 {0.8 to 2.4}	--	--	--	--	1960 {20.0}				

- Note) 1. In the case of using positioners, please the setting of supply pressure with pressure regulator.
 2. The maximum allowable differential pressures must not exceed the maximum working pressures specified by JISB2201-1984, ANSIB16.34-1981, and JPI-7S-65-831.
 3. In the differential pressure column, upper figures show normal differential pressures and lower figures differential pressures when the valve is fully closed.

Valve seat leakage, Class V and Class IV-S1: high shutoff model: metal seat

Table 17 Model AGVB nominal size 1/2, 3/4 and 1 inch

Note that the allowable differential pressure varies with the rated Cv value you have selected.

Air-to-open

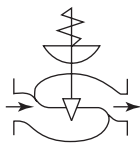

Nominal size (inch)	Actuator	Supply pressure kPa {kgf/cm ² }	Spring range kPa {kgf/cm ² }	Differential pressure (by Cv value) kPa {kgf/cm ² }					
				0.1	0.4	1.0	2.5	6.3	10
				0.16	0.63	1.6	4.0	8.0	14
1/2 3/4 1	PSA1R	270 {2.8}	80 to 240 {0.8 to 2.4}	1960 {20.0}					

- Note) 1. In the case of using positioners, please the setting of supply pressure with pressure regulator.
 2. The maximum allowable differential pressures must not exceed the maximum working pressures specified by JISB2201-1984, ANSIB16.34-1981, and JPI-7S-65-831.

Table 18 Model AGVB nominal size 1½, 2, 2½, 3 and 4 inches

Note that the allowable differential pressure varies with the port size (inches) you have selected

Air-to-open

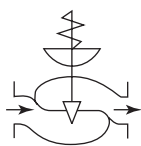

Nominal size (inches)	Actuator	Supply pressure kPa {kgf/cm ² }	Spring range kPa {kgf/cm ² }	Differential pressure (by port size (inches)) kPa {kgf/cm ² }						
				1	1¼	1½	2	2½	3	4
1½	PSA1R	270 {2.8}	80 to 240 {0.8 to 2.4}	1960 {20.0}	1110 {11.3}	660 {6.7}	270 {2.8}	--	--	--
	PSA2R	270 {2.8}	80 to 240 {0.8 to 2.4}	--	1960 {20.0}	1550 {15.8}	810 {8.2}	--	--	--
2	PSA3R	270 {2.8}	80 to 240 {0.8 to 2.4}	--	--	1960 {20.0}	1660 {16.9}	--	--	--
	PSA4R	270 {2.8}	80 to 240 {0.8 to 2.4}	--	--	--	1960 {20.0}	--	--	--
2½	PSA3R	270 {2.8}	80 to 240 {0.8 to 2.4}	--	--	1960 {20.0}	1660 {16.9}	910 {9.3}	570 {5.8}	190 {2.0}
	PSA4R	270 {2.8}	80 to 240 {0.8 to 2.4}	--	--	--	1960 {20.0}	1790 {18.2}	1200 {12.3}	550 {5.6}
3	PSA6R	260 {2.6}	100 to 180 {1.0 to 1.8}	--	--	--	--	1960 {20.0}	1850 {18.9}	910 {9.3}
		400 {4.0}	200 to 340 {2.0 to 3.5}	--	--	--	--	--	--	1960 {20.0}

- Note) 1. In the case of using positioners, please the setting of supply pressure with pressure regulator.
 2. The maximum allowable differential pressures must not exceed the maximum working pressures specified by JISB2201-1984, ANSIB16.34-1981, and JPI-7S-65-831.

Table 19 Model AGVB nominal size 1/2, 3/4 and 1 inch

Note that the allowable differential pressure varies with the rated Cv value you have selected.

Air-to-close

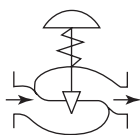

Nominal size (inch)	Actuator	Supply pressure kPa {kgf/cm ² }	Spring range kPa {kgf/cm ² }	Differential pressure (by Cv value) kPa {kgf/cm ² }					
				0.1	0.4	1.0	2.5	6.3	10
				0.16	0.63	1.6	4.0	8.0	14
1/2 3/4	PSA1D	160 {1.6}	20 to 98 {0.2 to 1.0}	1960 {20.0}				1640 {16.8}	1150 {11.7}
3/4		390 {4.0}	80 to 240 {0.8 to 2.4}						
1	PSA2D	160 {1.6}	20 to 98 {0.2 to 1.0}	--	--	--	--		

- Note) 1. In the case of using positioners, please the setting of supply pressure with pressure regulator.
 2. The maximum allowable differential pressures must not exceed the maximum working pressures specified by JISB2201-1984, ANSIB16.34-1981, and JPI-7S-65-831.

Valve seat leakage, Class V and Class IV-S1: high shutoff model: metal seat

Table 20 Model AGVB nominal size 1½, 2, 2½, 3, and 4 inches

Note that the allowable differential pressure varies with the port size (inches) you have selected.

Air-to-close

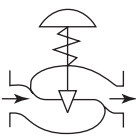

Nominal size (inches)	Actuator	Supply pressure kPa {kgf/cm ² }	Spring range kPa {kgf/cm ² }	Differential pressure (by port size (inches)) kPa {kgf/cm ² }						
				1	1¼	1½	2	2½	3	4
1½ 2	PSA1D	160 {1.6}	20 to 98 {0.2 to 1.0}	1150 {11.7}	600 {6.1}	310 {3.2}	--	--	--	--
		390 {4.0}	80 to 240 {0.8 to 2.4}	1960 {20.0}		1100 {11.2}	--	--	--	
	PSA2D	160 {1.6}	20 to 98 {0.2 to 1.0}	--	1430 {14.6}	880 {9.0}	410 {4.1}	--	--	--
		390 {4.0}	80 to 240 {0.8 to 2.4}	--	--	--	1960 {20.0}	--	--	--
	PSA3D	160 {1.6}	20 to 98 {0.2 to 1.0}	1960 {20.0}		1790 {18.3}	950 {9.7}	--	--	--
	PSA4D	160 {1.6}	20 to 98 {0.2 to 1.0}	1960 {20.0}		--	1850 {18.9}	--	--	--
2½ 3 4	PSA3D	160 {1.6}	20 to 98 {0.2 to 1.0}	--	--	1790 {18.2}	950 {9.7}	470 {4.8}	260 {2.6}	--
		390 {4.0}	80 to 240 {0.8 to 2.4}	--	--	1960 {20.0}		1830 {18.7}	900 {9.2}	
	PSA4D	160 {1.6}	20 to 98 {0.2 to 1.0}	--	--	--	1850 {18.9}	1030 {10.5}	660 {6.7}	240 {2.5}
		390 {4.0}	80 to 240 {0.8 to 2.4}	--	--	--	--	--	1960 {20.0}	1780 {18.1}

- Note) 1. In the case of using positioners, please the setting of supply pressure with pressure regulator.
 2. The maximum allowable differential pressures must not exceed the maximum working pressures specified by JISB2201-1984, ANSIB16.34-1981, and JPI-7S-65-831.

Table 21 Model AGVM nominal size 1/2, 3/4 and 1 inch

Note that the allowable differential pressure varies with the rated Cv value you have selected.

Air-to-open

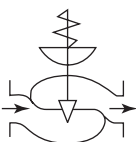

Nominal size (inch)	Actuator	Supply pressure kPa {kgf/cm ² }	Spring range kPa {kgf/cm ² }	Differential pressure (by Cv value) kPa {kgf/cm ² }					
				0.1	0.4	1.0	2.5	6.3	10
				0.16	0.63	1.6	4.0	8.0	14
1/2 3/4	PSA1R	270 {2.8}	80 to 240 {0.8 to 2.4}	1960 {20.0}					
				5100 {52.0}				2740 {28.0}	1970 {20.1}
1	PSA2R	270 {2.8}	80 to 240 {0.8 to 2.4}	--	--	--	--	1960 {20.0}	4110 {41.9}
				--	--	--	--	5100 {52.0}	

- Note) 1. In the case of using positioners, please the setting of supply pressure with pressure regulator.
 2. The maximum allowable differential pressures must not exceed the maximum working pressures specified by JISB2201-1984, ANSIB16.34-1981, and JPI-7S-65-831.
 3. In the differential pressure column, upper figures show normal differential pressures and lower figures differential pressures when the valve is fully closed.

Valve seat leakage, Class V and Class IV-S1: high shutoff model: metal seat

Table 22 Model AGVM nominal size 1½, 2, 2½, 3 and 4 inches

Note that the allowable differential pressure varies with the port size (inches) you have selected.

Air-to-open

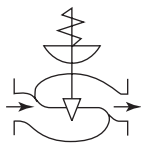

Nominal size (inches)	Actuator	Supply pressure kPa {kgf/cm ² }	Spring range kPa {kgf/cm ² }	Differential pressure (by port size (inches)) kPa {kgf/cm ² }						
				1	1¼	1½	2	2½	3	4
1½	PSA1R	270 {2.8}	80 to 240 {0.8 to 2.4}	1960 {20.0}	1110 {11.3}	660 {6.7}	270 {2.8}	--	--	--
				1980 {20.2}				--	--	--
	PSA2R	270 {2.8}	80 to 240 {0.8 to 2.4}	1960 {20.0}		1550 {15.8}	810 {8.2}	--	--	--
				4110 {41.9}	2420 {24.7}					
2	PSA3R	270 {2.8}	80 to 240 {0.8 to 2.4}	1960 {20.0}			1660 {16.9}	--	--	--
				5100 {52.0}	4520 {46.1}	2970 {30.3}				
	PSA4R	270 {2.8}	80 to 240 {0.8 to 2.4}	--	1960 {20.0}		3080 {31.4}	--	--	--
					5100 {52.0}					
2½	PSA3R	270 {2.8}	80 to 240 {0.8 to 2.4}	--	--	1960 {20.0}	1660 {16.9}	910 {9.3}	570 {5.8}	190 {2.0}
						2970 {30.3}				
	PSA4R	270 {2.8}	80 to 240 {0.8 to 2.4}	--	--	1960 {20.0}		1790 {18.2}	1200 {12.3}	550 {5.6}
						5100 {52.0}	3080 {31.4}			
3	PSA6R	260 {2.6}	100 to 180 {1.0 to 1.8}	--	--	--	--	1960 {20.0}	1850 {18.9}	910 {9.3}
								2680 {27.3}		
4		400 {4.0}	200 to 340 {2.0 to 3.5}	--	--	--	1960 {20.0}			
							5100 {52.0}	4710 {48.0}	2520 {25.7}	

- Note) 1. In the case of using positioners, please the setting of supply pressure with pressure regulator.
 2. The maximum allowable differential pressures must not exceed the maximum working pressures specified by JISB2201-1984, ANSIB16.34-1981, and JPI-7S-65-831.
 3. In the differential pressure column, upper figures show normal differential pressures and lower figures differential pressures when the valve is fully closed.

Table 23 Model AGVM nominal size 1/2, 3/4 and 1 inch

Note that the allowable differential pressure varies with the rated Cv value you have selected.

Air-to-close

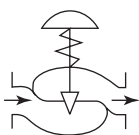

Nominal size (inch)	Actuator	Supply pressure kPa {kgf/cm ² }	Spring range kPa {kgf/cm ² }	Differential pressure (by Cv value) kPa {kgf/cm ² }						
				0.1 0.16 0.25	0.4 0.63	1.0 1.6	2.5 4.0	6.3 8.0	10 14	
1/2	PSA1D	160 {1.6}	20 to 98 {0.2 to 1.0}	1960 {20.0}				1640 {16.8}	1150 {11.7}	
				5100 {52.0}		3270 {33.3}				
3/4	PSA1D	390 {4.0}	80 to 240 {0.8 to 2.4}	1960 {20.0}				--	--	
				5100 {52.0}						
1	PSA2D	160 {1.6}	20 to 98 {0.2 to 1.0}	--	--	--	1960 {20.0}			
							5100 {52.0}	3460 {35.3}	2500 {25.5}	

- Note) 1. In the case of using positioners, please the setting of supply pressure with pressure regulator.
 2. The maximum allowable differential pressures must not exceed the maximum working pressures specified by JISB2201-1984, ANSIB16.34-1981, and JPI-7S-65-831.
 3. In the differential pressure column, upper figures show normal differential pressures and lower figures differential pressures when the valve is fully closed.

Valve seat leakage, Class V and Class IV-S1: high shutoff model: metal seat

Table 24 Model AGVM nominal size 1½, 2, 2½, 3 and 4 inches

Note that the allowable differential pressure varies with the port size (inches) you have selected.

Air-to-close

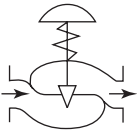

Nominal size (inches)	Actuator	Supply pressure kPa {kgf/cm ² }	Spring range kPa {kgf/cm ² }	Differential pressure (by port size (inches)) kPa {kgf/cm ² }							
				1	1¼	1½	2	2½	3	4	
1½	PSA1D	160 {1.6}	20 to 98 {0.2 to 1.0}	1150 {11.7}	600 {6.1}	310 {3.2}	--	--	--	--	
		390 {4.0}	80 to 240 {0.8 to 2.4}	1960 {20.0}			1100 {11.2}	--	--	--	
	PSA2D	160 {1.6}	20 to 98 {0.2 to 1.0}	1960 {20.0}	1430 {14.6}	880 {9.0}	410 {4.1}	--	--	--	
		390 {4.0}	80 to 240 {0.8 to 2.4}	--	1960 {20.0}			--	--	--	
	2	PSA3D	160 {1.6}	20 to 98 {0.2 to 1.0}	1960 {20.0}		1790 {18.3}	950 {9.7}	--	--	--
			390 {4.0}	80 to 240 {0.8 to 2.4}	--	--	1960 {20.0}		--	--	--
		PSA4D	160 {1.6}	20 to 98 {0.2 to 1.0}	5100 {52.0}	5000 {51.0}	3300 {33.6}	1850 {18.9}	--	--	--
			390 {4.0}	80 to 240 {0.8 to 2.4}	--	--	--	1960 {20.0}	--	--	--
	2½	PSA3D	160 {1.6}	20 to 98 {0.2 to 1.0}	--	--	1790 {18.2}	950 {9.7}	470 {4.8}	260 {2.6}	--
			390 {4.0}	80 to 240 {0.8 to 2.4}	--	--	1960 {20.0}			1830 {18.7}	900 {9.2}
		PSA4D	160 {1.6}	20 to 98 {0.2 to 1.0}	--	--	1960 {20.0}	1850 {18.9}	1030 {10.5}	660 {6.7}	240 {2.5}
			390 {4.0}	80 to 240 {0.8 to 2.4}	--	--	--	1960 {20.0}			1770 {18.0}
160 {1.6}			20 to 98 {0.2 to 1.0}	--	--	3290 {33.6}	1850 {18.9}	1030 {10.5}	660 {6.7}	240 {2.5}	
390 {4.0}			80 to 240 {0.8 to 2.4}	--	--	--	5100 {52.0}	4810 {49.1}	3370 {34.4}	1770 {18.0}	

- Note) 1. In the case of using positioners, please the setting of supply pressure with pressure regulator.
 2. The maximum allowable differential pressures must not exceed the maximum working pressures specified by JISB2201-1984, ANSIB16.34-1981, and JPI-7S-65-831.
 3. In the differential pressure column, upper figures show normal differential pressures and lower figures differential pressures when the valve is fully closed.

Valve seat leakage, Class VI: high shutoff model: soft seat

Table 25 Model AGVB nominal size 1/2, 3/4 and 1 inch

Note that the allowable differential pressure varies with the rated Cv value you have selected.

Air-to-open

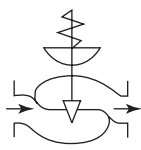

Nominal size (inch)	Actuator	Supply pressure kPa {kgf/cm ² }	Spring range kPa {kgf/cm ² }	Differential pressure (by Cv value) kPa {kgf/cm ² }					
				0.1 0.16 0.25	0.4 0.63	1.0 1.6	2.5 4.0	6.3 8.0	10 14
1/2	PSA1R	270 {2.8}	80 to 240 {0.8 to 2.4}	1960 {20.0}				1440 {14.7}	1030 {10.5}
3/4									
1	PSA2R	270 {2.8}	80 to 240 {0.8 to 2.4}	--	--	--	--	1960 {20.0}	

- Note) 1. In the case of using positioners, please the setting of supply pressure with pressure regulator.
 2. The maximum allowable differential pressures must not exceed the maximum working pressures specified by JISB2201-1984, ANSIB16.34-1981, and JPI-7S-65-831.

Table 26 Model AGVB nominal size 1½, 2, 2½, 3 and 4 inches

Note that the allowable differential pressure varies with the port size (inches) you have selected.

Air-to-open

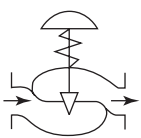

Nominal size (inches)	Actuator	Supply pressure kPa {kgf/cm ² }	Spring range kPa {kgf/cm ² }	Differential pressure (by port size (inches)) kPa {kgf/cm ² }						
				1	1¼	1½	2	2½	3	4
1½	PSA1R	270 {2.8}	80 to 240 {0.8 to 2.4}	1030 {10.5}	460 {4.7}	190 {1.9}	--	--	--	--
	PSA2R	270 {2.8}	80 to 240 {0.8 to 2.4}	1960 {20.0}	1740 {17.7}	1270 {13.0}	640 {6.5}	--	--	--
2	PSA3R	270 {2.8}	80 to 240 {0.8 to 2.4}	--	1960 {20.0}		1580 {16.1}	--	--	--
	PSA4R	270 {2.8}	80 to 240 {0.8 to 2.4}	--	--	--	1960 {20.0}	--	--	--
2½	PSA3R	270 {2.8}	80 to 240 {0.8 to 2.4}	--	--	1960 {20.0}	1580 {16.1}	960 {9.8}	640 {6.5}	280 {2.9}
3	PSA4R	270 {2.8}	80 to 240 {0.8 to 2.4}	--	--	--	1960 {20.0}	1920 {19.6}	1450 {14.8}	770 {7.9}
4										

- Note) 1. In the case of using positioners, please the setting of supply pressure with pressure regulator.
 2. The maximum allowable differential pressures must not exceed the maximum working pressures specified by JISB2201-1984, ANSIB16.34-1981, and JPI-7S-65-831.

Table 27 Model AGVB nominal size 1/2, 3/4 and 1 inch

Note that the allowable differential pressure varies with the rated Cv value you have selected.

Air-to-close

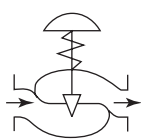

Nominal size (inch)	Actuator	Supply pressure kPa {kgf/cm ² }	Spring range kPa {kgf/cm ² }	Differential pressure (by Cv value) kPa {kgf/cm ² }					
				0.1 0.16 0.25	0.4 0.63	1.0 1.6	2.5 4.0	6.3 8.0	10 14
1/2	PSA1D	140 {1.4}	20 to 98 {0.2 to 1.0}	1240 {12.6}	1240 {12.6}	690 {7.0}	110 {1.1}	--	--
		160 {1.6}	20 to 98 {0.2 to 1.0}	1960 {20.0}		1480 {15.1}	640 {6.5}	330 {3.4}	
3/4		390 {1.4}	80 to 240 {0.8 to 2.4}	--	--	--	1960 {20.0}		
1	PSA2D	140 {1.4}	20 to 98 {0.2 to 1.0}	1960 {20.0}		1910 {19.5}	1230 {12.5}	790 {8.1}	
		160 {1.6}	20 to 98 {0.2 to 1.0}	--	--	--	1960 {20.0}	1750 {17.8}	

- Note) 1. In the case of using positioners, please the setting of supply pressure with pressure regulator.
 2. The maximum allowable differential pressures must not exceed the maximum working pressures specified by JISB2201-1984, ANSIB16.34-1981, and JPI-7S-65-831.

Valve seat leakage, Class VI: high shutoff model: soft seat

Table 28 Model AGVB nominal size 1½, 2, 2½, 3, and 4 inches

Note that the allowable differential pressure varies with the port size (inches) you have selected.

Air-to-close

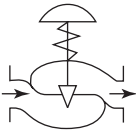

Nominal size (inches)	Actuator	Supply pressure kPa {kgf/cm ² }	Spring range kPa {kgf/cm ² }	Differential pressure (by port size (inches)) kPa {kgf/cm ² }							
				1	1¼	1½	2	2½	3	4	
1½ 2	PSA1D	390 {4.0}	80 to 240 {0.8 to 2.4}	1960 {20.0}	1860 {19.0}	1390 {14.2}	730 {7.4}	--	--	--	
	PSA2D	140 {1.4}	20 to 98 {0.2 to 1.0}	790 {8.1}	310 {3.2}	--	--	--	--	--	
		160 {1.6}	20 to 98 {0.2 to 1.0}	1750 {17.8}	1170 {11.9}	680 {6.9}	280 {2.9}	--	--	--	
		390 {4.0}	80 to 240 {0.8 to 2.4}	--	1960 {20.0}		1860 {18.0}	--	--	--	
	PSA3D	140 {1.4}	20 to 98 {0.2 to 1.0}	1960 {20.0}	1410 {1.41}	880 {9.0}	400 {4.1}	--	--	--	
		160 {1.6}	20 to 98 {0.2 to 1.0}		1710 {17.4}		1050 {10.7}	--	--	--	
		390 {4.0}	80 to 240 {0.8 to 2.4}	--	--	--	1960 {20.0}	--	--	--	
	PSA4D	140 {1.4}	20 to 98 {0.2 to 1.0}	1960 {20.0}			1320 {13.5}	--	--	--	
		160 {1.6}	20 to 98 {0.2 to 1.0}	--	--	--	--	--	--		
	2½ 3 4	PSA3D	140 {1.4}	20 to 98 {0.2 to 1.0}	--	--	880 {9.0}	400 {4.1}	150 {1.5}	--	--
			160 {1.6}	20 to 98 {0.2 to 1.0}	--	--	1710 {17.4}	1050 {10.7}	550 {5.6}	340 {3.5}	110 {1.1}
			390 {4.0}	80 to 240 {0.8 to 2.4}	--	--	1710 {17.4}			960 {9.8}	
PSA4D		140 {1.4}	20 to 98 {0.2 to 1.0}	--	--	1960 {20.0}	1320 {13.5}	730 {7.4}	470 {4.8}	190 {1.9}	
		160 {1.6}	20 to 98 {0.2 to 1.0}	--	--		1410 {14.4}		980 {10.0}	480 {4.9}	
		390 {4.0}	80 to 240 {0.8 to 2.4}	--	--	--	--	1960 {20.0}	1960 {20.0}	1820 {18.6}	

- Note) 1. In the case of using positioners, please the setting of supply pressure with pressure regulator.
 2. The maximum allowable differential pressures must not exceed the maximum working pressures specified by JISB2201-1984, ANSIB16.34-1981, and JPI-7S-65-831.

Table 29 Model AGVM nominal size 1/2, 3/4 and 1 inch

Note that the allowable differential pressure varies with the rated Cv value you have selected.

Air-to-open

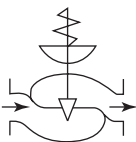

Nominal size (inch)	Actuator	Supply pressure kPa {kgf/cm ² }	Spring range kPa {kgf/cm ² }	Differential pressure (by Cv value) kPa {kgf/cm ² }					
				0.1 0.16 0.25	0.4 0.63	1.0 1.6	2.5 4.0	6.3 8.0	10 14
1/2 3/4	PSA1R	270 {2.8}	80 to 240 {0.8 to 2.4}	1960 {20.0}				1440 {14.7}	1030 {10.5}
				2940 {30.0}		2850 {29.1}	2140 {21.8}		
1	PSA2R	270 {2.8}	80 to 240 {0.8 to 2.4}	--	--	1960 {20.0}		2450 {25.0}	
						2940 {30.0}			

- Note) 1. In the case of using positioners, please the setting of supply pressure with pressure regulator.
 2. The maximum allowable differential pressures must not exceed the maximum working pressures specified by JISB2201-1984, ANSIB16.34-1981, and JPI-7S-65-831.
 3. In the differential pressure column, upper figures show normal differential pressures and lower figures differential pressures when the valve is fully closed.

Valve seat leakage, Class VI: high shutoff model: soft seat

Table 30 Model AGVM nominal size 1½, 2, 2½, 3 and 4 inches

Note that the allowable differential pressure varies with the port size (inches) you have selected.

Air-to-open

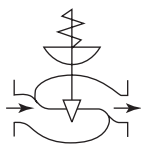

Nominal size inches	Actuator	Supply pressure kPa {kgf/cm ² }	Spring range kPa {kgf/cm ² }	Differential pressure (by port size (inches)) kPa {kgf/cm ² }						
				1	1¼	1½	2	2½	3	4
1½ 2	PSA1R	270{2.8}	80 to 240 {0.8 to 2.4}	1030 {10.5}	460 {4.7}	180 {0.17}	--	--	--	--
	PSA2R	270{2.8}	80 to 240 {0.8 to 2.4}	1960 {20.0}	1740 {17.7}	1270 {13.0}	640 {6.5}	--	--	--
				2450 {25.0}						
	PSA3R	270{2.8}	80 to 240 {0.8 to 2.4}	1960 {20.0}		1580 {16.1}		--	--	--
2940 {30.0}				2370 {24.2}						
PSA4R	270{2.8}	80 to 240 {0.8 to 2.4}	--	--	1960 {20.0}		--	--	--	
					2940 {30.0}	2840 {29.0}				
2½ 3	PSA3R	270{2.8}	80 to 240 {0.8 to 2.4}	--	--	1960 {20.0}	1580 {16.1}	960 {9.8}	640 {6.5}	280 {2.9}
						2370 {24.2}				
4	PSA4R	270{2.8}	80 to 240 {0.8 to 2.4}	--	--	1960 {20.0}		1920 {19.6}	1450 {14.8}	770 {7.9}
						2940 {30.0}	2.84 {29.0}			

- Note) 1. In the case of using positioners, please the setting of supply pressure with pressure regulator.
 2. The maximum allowable differential pressures must not exceed the maximum working pressures specified by JISB2201-1984, ANSIB16.34-1981, and JPI-7S-65-831.
 3. In the differential pressure column, upper figures show normal differential pressures and lower figures differential pressures when the valve is fully closed.

Table 31 Model AGVM nominal size 1/2, 3/4 and 1 inch

Note that the allowable differential pressure varies with the rated Cv value you have selected.

Air-to-close

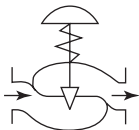

Nominal size (inch)	Actuator	Supply pressure kPa {kgf/cm ² }	Spring range kPa {kgf/cm ² }	Differential pressure (by Cv value) kPa {kgf/cm ² }						
				0.1 160 0.25	0.4 0.63	1.0 1.6	2.5 4.0	6.3 8.0	10 14	
1/2	PSA1D	140 {1.4}	20 to 98 {0.2 to 1.0}	1240 {12.6}	1240 {12.6}	690 {7.0}	110 {1.1}	--	--	
		160 {1.6}	20 to 98 {0.2 to 1.0}	1960 {20.0}		1480 {15.1}		640 {6.5}	330 {3.4}	
				2310 {23.6}	1980 {20.2}					
3/4	PSA1D	390 {4.0}	80 to 240 {0.8 to 2.4}	1960 {20.0}		2620 {26.7}				
				2940 {30.0}						
1	PSA2D	140 {1.4}	20 to 98 {0.2 to 1.0}	1960 {20.0}		1910 {19.5}	1230 {12.6}	790 {8.1}		
		160 {1.6}	20 to 98 {0.2 to 1.0}	1960 {20.0}		1750 {17.9}				
				2940 {30.0}	2140 {21.8}					
390 {4.0}	80 to 240 {0.8 to 2.4}	--	--	--	--	--	1960 {20.0}			
							2940 {30.0}			

- Note) 1. In the case of using positioners, please the setting of supply pressure with pressure regulator.
 2. The maximum allowable differential pressures must not exceed the maximum working pressures specified by JISB2201-1984, ANSIB16.34-1981, and JPI-7S-65-831.
 3. In the differential pressure column, upper figures show normal differential pressures and lower figures differential pressures when the valve is fully closed.

Valve seat leakage, Class VI: high shutoff model: soft seat

Table 32 Model AGVM nominal size 1½, 2, 2½, 3 and 4 inches

Note that the allowable differential pressure varies with the port size (inches) you have selected.

Air-to-close

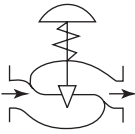

Nominal size inches	Actuator	Supply pressure kPa {kgf/cm ² }	Spring range kPa {kgf/cm ² }	Differential pressure (by port size (inches)) kPa {kgf/cm ² }							
				1	1¼	1½	2	2½	3	4	
1½ 2	PSA1D	160 {1.6}	20 to 98 {0.2 to 1.0}	330 {3.4}	--	--	--	--	--	--	--
		390 {4.0}	80 to 240 {0.8 to 2.4}	1960 {20.0} 2620 {26.7}	1860 {18.9}	1390 {14.2}	730 {7.4}	--	--	--	
	PSA2D	140 {1.4}	20 to 98 {0.2 to 1.0}	790 {8.1}	310 {3.2}	--	--	--	--	--	--
		160 {1.6}	20 to 98 {0.2 to 1.0}	1750 {17.8}	1170 {11.9}	680 {6.9}	280 {2.9}	--	--	--	
	PSA3D	390 {4.0}	80 to 240 {0.8 to 2.4}	1960 {20.0}		1860 {19.0}		--	--	--	--
		140 {1.4}	20 to 98 {0.2 to 1.0}	1990 {20.3}	1410 {14.4}	880 {9.0}	400 {4.1}	--	--	--	
	PSA4D	160 {1.6}	20 to 98 {0.2 to 1.0}	1960 {20.0}		1710 {17.4}		1050 {10.7}	--	--	--
		390 {4.0}	80 to 240 {0.8 to 2.4}	--	--	1960 {20.0}		2940 {30.0}	--	--	
	PSA3D	140 {1.4}	20 to 98 {0.2 to 1.0}	1960 {20.0}		1320 {13.5}		--	--	--	
		160 {1.6}	20 to 98 {0.2 to 1.0}	--	--	1960 {20.0}		2940 {30.0}	1990 {21.3}	--	--
	2½ 3 4	PSA3D	140 {1.4}	20 to 98 {0.2 to 1.0}	--	--	880 {9.0}	400 {4.1}	150 {1.5}	--	--
			160 {1.6}	20 to 98 {0.2 to 1.0}	--	--	1710 {17.4}	1050 {10.7}	550 {5.6}	340 {3.5}	110 {1.1}
390 {4.0}			80 to 240 {0.8 to 2.4}	--	--	1960 {20.0}		2250 {22.9}	1710 {17.4}	960 {9.8}	
PSA4D		140 {1.4}	20 to 98 {0.2 to 1.0}	--	--	1990 {20.3}	1320 {13.5}	730 {7.4}	470 {4.8}	190 {1.9}	
		160 {1.6}	20 to 98 {0.2 to 1.0}	--	--	1960 {20.0}		2090 {21.3}	1410 {14.4}	980 {10.0}	480 {4.9}
		390 {4.0}	80 to 240 {0.8 to 2.4}	--	--	--	--	1960 {20.0}		2940 {30.0}	1820 {18.6}

- Note) 1. In the case of using positioners, please the setting of supply pressure with pressure regulator.
 2. The maximum allowable differential pressures must not exceed the maximum working pressures specified by JISB2201-1984, ANSIB16.34-1981, and JPI-7S-65-831.
 3. In the differential pressure column, upper figures show normal differential pressures and lower figures differential pressures when the valve is fully closed.

5. Accessories

5-1 Hand wheel

Use: The manual hand wheel enables you to open and close the valve manually.
Orientation: Side hand wheel, which is mounted to the yoke of the actuator.

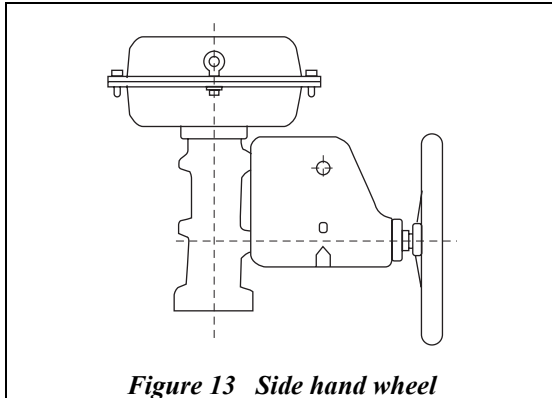
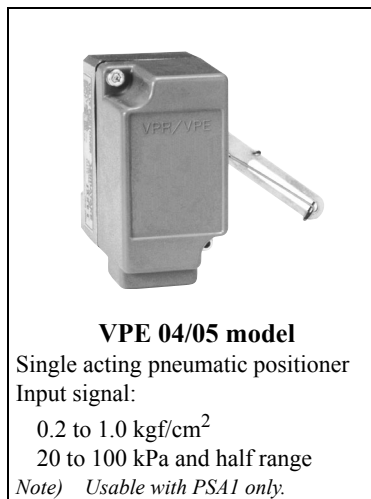

Figure 13 Side hand wheel

5-2 Positioner

Use: In response to input signals from the controller, the positioner controls the valve accurately and swiftly, switches between direct and reverse operation, and changes valve characteristics.

Models: According to input signals and applications, select one of the models shown below.



VPE 04/05 model

Single acting pneumatic positioner

Input signal:

0.2 to 1.0 kgf/cm²

20 to 100 kPa and half range

Note) Usable with PSA1 only.

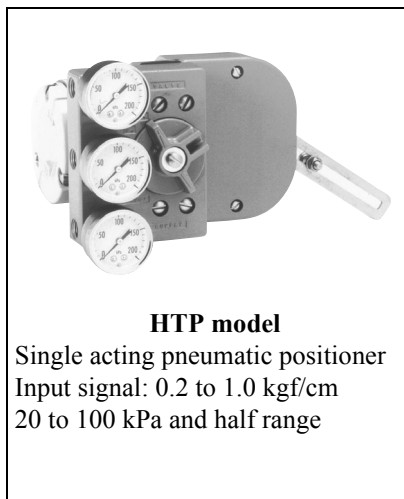

HTP model

Single acting pneumatic positioner

Input signal: 0.2 to 1.0 kgf/cm

20 to 100 kPa and half range

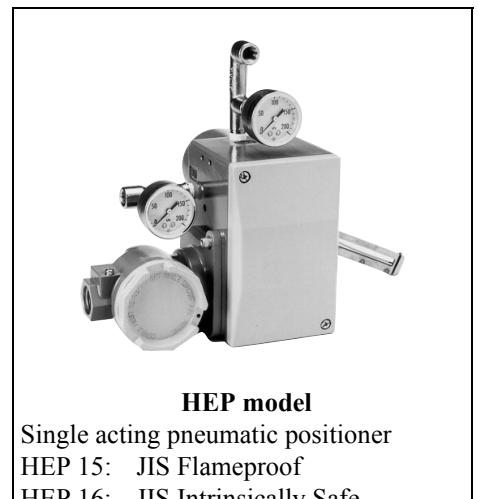

HEP model

Single acting pneumatic positioner

HEP 15: JIS Flameproof

HEP 16: JIS Intrinsically Safe

HEP 17: JIS Safe water-proof

HEP 18: FM intrinsically safe

HEP 19: FM intrinsically safe

Input signal: 4 to 20mA DC

Half range: (4 to 12 or 12 to 20mA DC)

Note) In the photograph, the pressure regulator is attached.

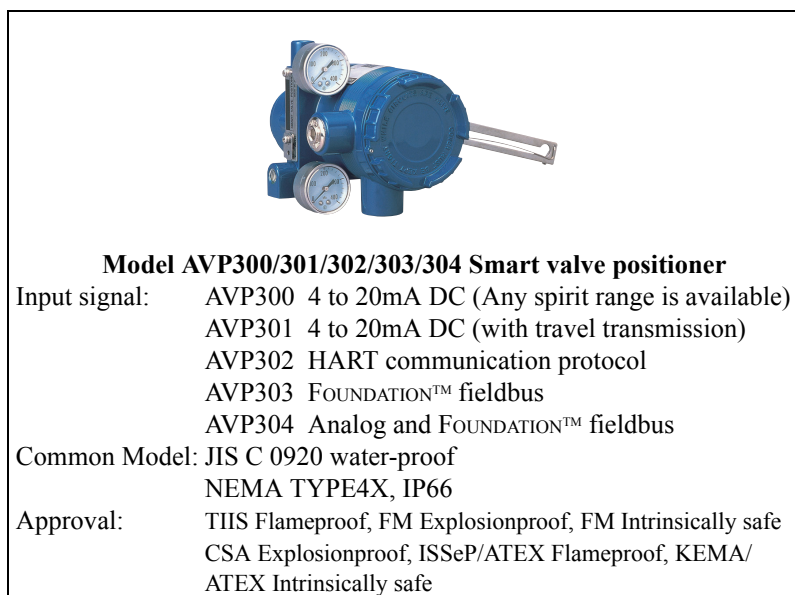

Model AVP300/301/302/303/304 Smart valve positioner

Input signal: AVP300 4 to 20mA DC (Any spirit range is available)

AVP301 4 to 20mA DC (with travel transmission)

AVP302 HART communication protocol

AVP303 FOUNDATION™ fieldbus

AVP304 Analog and FOUNDATION™ fieldbus

Common Model: JIS C 0920 water-proof

NEMA TYPE4X, IP66

Approval: TIIS Flameproof, FM Explosionproof, FM Intrinsically safe

CSA Explosionproof, ISSeP/ATEX Flameproof, KEMA/

ATEX Intrinsically safe

5-3 Pressure regulator with filter

Function: The Pressure regulator with filter reduce the pressure of application air, drains application air, and removes foreign substances.

Model: The model KZ03 is the standard.



KZ03 Pressure regulator with filter

5-4 Solenoid valve

Function: Electric signals make the solenoid valve to open and close the control valve.

Model: According to applications, select one of those shown below.

Waterproof model:

J320b175type (Maker: Nippon Asco)

Explosionproof model: JE3J320G174 (Maker: Nippon Asco)

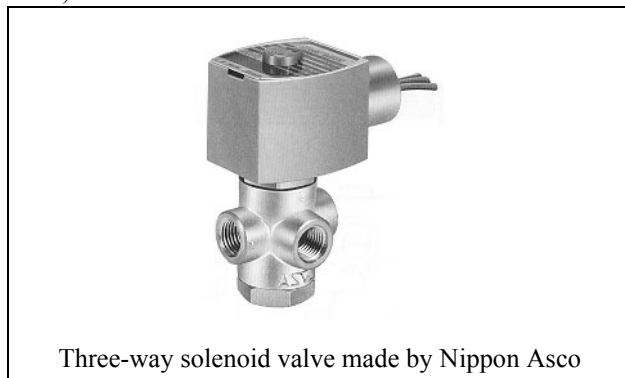

Three-way solenoid valve made by Nippon Asco

5-5 Limit switch

Function: The limit switch converts the open and closed positions of the control valve into electric signals.

Model: The roller lever actuator is standard. According to applications, select one of the models shown below.

Waterproof model: VCL5001

Explosionproof model: VCX5001



Roller lever type limit switch

5-6 Booster relay

Use: The booster relay improves the working speed of the control valve.

Model: Use a booster relay that amplifies the output signals of the positioner.



Booster relay (IL 100-02) made by SMC

5-7 Lock-up valve

Function: In response to air pressure signals or in anticipations of fluctuations in the supply pressure, the lock-up valve maintains the position of the control valve.

Model: single acting selector switch, which reverts on pressure recovery. You can freely set the change-over pressure within the range from 140 to 690 kPa.



Lock-up valve (IL 201-02 type) made by SMC

Please check specification (explosion proof, power supply or additional voltage, connection method of electric wiring) about electric equipment, such as positioner, solenoid valve and limit switch.

6. Dimensions and weight

Table 33 and 34 show the dimensions and weight of the control valves. Note that the addition of any optional specifications will change their installed dimensions and weights.

Table 33 Main dimensions

Connection diameter (inches)	Actuator	Dimensions (mm)											
		A			H			B	Classified by positioner C				
		JIS10K ANSI150 JPI150 *1	JIS16K	JIS20K, 30K ANSI300 JPI300 *1	General use bonnet	Extension type I bonnet	Extension type II bonnet		VPE	HTP	HEP	AVP	
										with pressure regulator with filter	without pressure regulator with filter		
1/2, 3/4	PSA1D, R	184	190	194	420	545	945	218	145	225	290	312	221
	PSA2D, R				450	575	975	267	--				
1	PSA1D, R	184	193	197	420	545	945	218	145	225	290	312	221
	PSA2D, R				450	575	975	267	--				
1½	PSA1D, R	222	231	235	420	605	945	218	145	225	290	312	221
	PSA2D, R				450	635	975	267	--				
	PSA3D, R				630	760	1160	350	--	270	330	318	227
	PSA4D, R				680	815	1215	470	--				
2	PSA1D, R	254	263	267	420	605	945	218	145	225	290	312	221
	PSA2D, R				450	635	975	267	--				
	PSA3D, R				630	760	1160	350	--	270	330	318	227
	PSA4D, R				680	815	1215	470	--				
2½	PSA3D, R	276	288	292	675	800	1155	350	--	270	330	318	227
	PSA4D, R				725	855	1210	470	--				
	PSA6R				1145	1275	--	470	--	348	257		
3	PSA3D, R	298	313	317	675	800	1155	350	--	270	330	318	227
	PSA4D, R				725	855	1210	470	--				
	PSA6R				1145	1275	1710	470	--	348	257		
4	PSA3D, R	352	364	368	680	800	1155	350	--	270	330	318	227
	PSA4D, R				730	860	1210	470	--				
	PSA6R				1150	1275	1710	470	--	348	257		

Note) *1 : Face-to-face dimensions conform to following standards.

- IEC 60534-3-1:2001

- JIS B 2005-3-1:2005

*2 : H +135 mm for PSA6 with hand wheel.

Table 34 Product weight (kg)

Actuator	Body size (inches)	1/2		3/4		1		1½	
	Pressure rating	JIS 10K ANSI 150 JPI 150	JIS 20K ANSI 300 JPI 300	JIS 10K ANSI 150 JPI 150	JIS 20K ANSI 300 JPI 300	JIS 10K ANSI 150 JPI 150	JIS 20K ANSI 300 JPI 300	JIS 10K ANSI 150 JPI 150	JIS 20K ANSI 300 JPI 300
PSA 1		15	16	16	19	17	19	27	32
PSA 2		18	19	19	22	20	22	30	35
PSA 3		--	--	--	--	--	--	50	55
PSA 4		--	--	--	--	--	--	68	73
PSA 6		--	--	--	--	--	--	--	--

Actuator	Body size (inches)	2		2½		3		4	
	Pressure rating	JIS 10K ANSI 150 JPI 150	JIS 20K ANSI 300 JPI 300	JIS 10K ANSI 150 JPI 150	JIS 20K ANSI 300 JPI 300	JIS 10K ANSI 150 JPI 150	JIS 20K ANSI 300 JPI 300	JIS 10K ANSI 150 JPI 150	JIS 20K ANSI 300 JPI 300
PSA 1		30	33	--	--	--	--	--	--
PSA 2		33	36	--	--	--	--	--	--
PSA 3		53	56	71	77	73	81	89	106
PSA 4		71	74	89	95	91	99	107	124
PSA 6		--	--	190	197	192	201	208	225

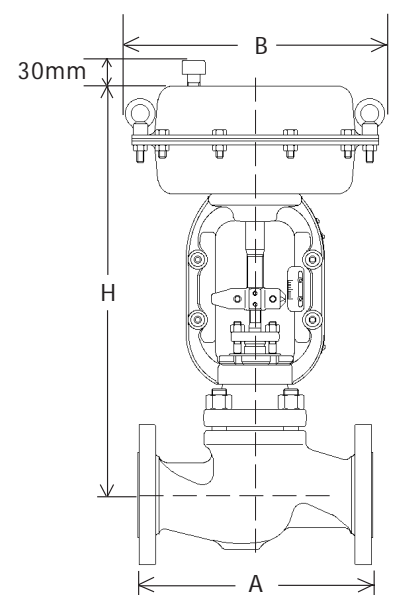

Figure 14 Face-to-face dimensions and overall dimensions

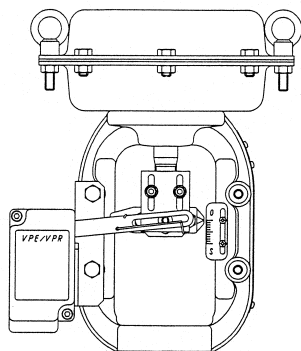

Figure 15 VPE positioner mounted

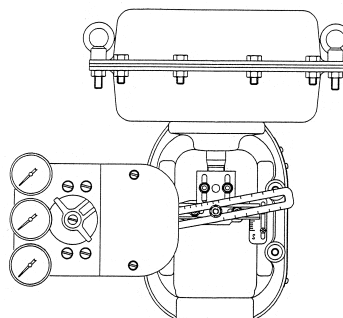

Figure 16 HTP positioner mounted

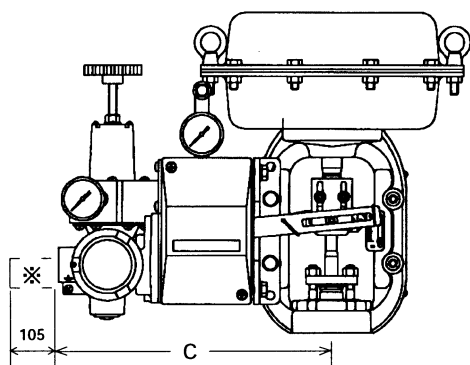

Figure 17 HEP positioner mounted

Note) * When applying a pressure proof packing, add 105 mm.

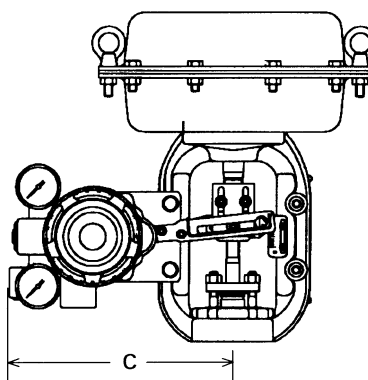

Figure 18 AVP positioner mounted

The overall dimensions and the valve weight will change when a manual hand wheel is mounted. In standard mounting, the position of operation of the side hand wheel is at the back of the actuator (on the side opposite that the valve positioner is mounted).

Table 35 Hand wheel dimensions

Type of hand wheel	Actuator	Dimension (mm)			Maximum driving force of hand wheel N (kgf)	Weight (kg)
		I max.	F	K		
Side hand wheel	PSA1D, R	---	200	215	80 (8)	7
	PSA2D, R	---	200		150 (15)	
	PSA3D, R	---	355	345	260 (27)	27
	PSA4D, R	---	355		450 (46)	
	PSA6R	---	380	310	127 (13)	35

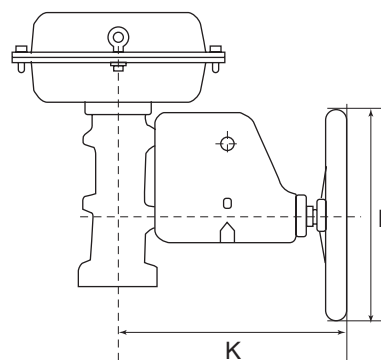

Figure 19 Side hand wheel

7. Actuator Orientation

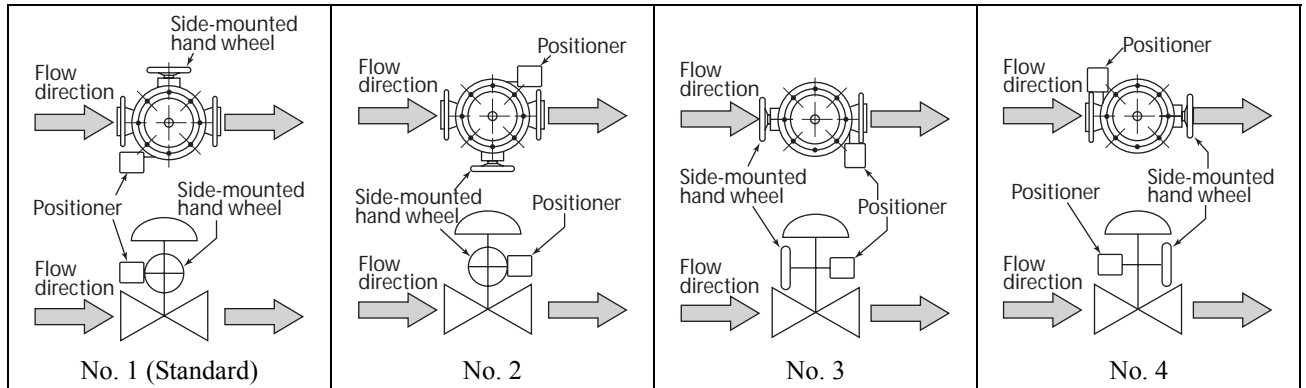

Figure 20 Actuator orientation

Note) Indicate by position number when installation other than the standard type is required.

MODEL SELECTION

CV3000 Alphaplus model number construction table (model AGVB)

Please specify one of the following codes in the top row. Select a code from each of the columns and write it in the blank box directly above it.
 Model AGVB - I II III IV V VI VII VIII IX X XI - XII XIII XIV XV XVI - Option

Basic model no.

Selection

AGVB												
I	Nominal size	1/2 inch	1									
		3/4 inch	2									
		1 inch	3									
		1 1/2 inch	4									
		2 inches	5									
		2 1/2 inches	6									
		3 inches	7									
		4 inches	8									
II	Port size & Plug flow characteristics *5	Cv=0.1 Linear *5	A									
		Cv=0.16 Linear *5	B									
		Cv=0.25 Linear *5	C									
		Cv=0.4 EQ%	D									
		Cv=0.63 EQ%	E									
		Cv=1.0 EQ%	F									
		Cv=1.6 EQ%	G									
		Cv=2.5 EQ%	H									
		Cv=4.0 EQ%	J									
		Cv=6.3 EQ%	4									
		Cv=8.0 EQ%	K									
		Cv=10 EQ%	L									
		1 inch, Cv=14 EQ%	M									
		1 1/4 inch EQ%	N									
		1 1/2 inch EQ%	P									
		2 inches EQ%	R									
2 1/2 inches EQ%	S											
3 inches EQ%	T											
4 inches EQ%	U											
III	Conn. rating	JIS 10K RF	J									
		ANSI 150 RF	A									
		JPI 150 RF	P									
IV	Bonnet	Standard type (17 to +230°C)	1									
		Extension (-45 to -17°C or +230 to 400°C) type I	2									
		Extension type II (-196 to 45 deg.C)	3									
V	Body material	SCPH2	1									
		SCS13A	2									
		SCS14A	3									
		A216WCB	A									
		A351CF8	B									
		A351CF8M	C									
		Others	Enter client's requirement	9								
VI	Plug & Seat material	SUS316	2									
		SUS316 Stellite	4									
		SUS440C	5									
		SUS316 Soft seat	6									
		SUS316 Stellite face *5	7									
		SUS316L	8									
		SUS316L Stellite	A									
		SUS316L Soft seat	B									
		Others	Enter client's requirement	9								
		VII	Seat leakage	Class IV: 0.01% of the rated Cv value	1							
Class V: high shutoff model: Metal seat Seat: Stellite or 440C	2											
Class VI: shut-off performance (Soft seat)	3											
Class IV-SI: (Ultra low leakage) Seat: Stellite or 440C	4											
VIII	Gland packing	PTFE yarn (General use)	1									
		V shaped PTFE (for general)	2									
		V shaped PTFE (for oil-free) (Delete)	A									
		V shaped PTFE (D)+(R) (for vacuum service)	3									
		V shaped PTFE (for low temp. service)	5									
		Graphite yarn (for hi temp./ Water resistant)	4									
		Graphite yarn (for hi&lo temp./ Oil-free)	6									
		Graphite yarn (Anti-Alkaline or Acid service)	7									
		Graphite yarn (for solvent service)	8									
Others	Enter client's requirement	9										
IX	Actuator and valve action	PSA1R Reverse action (Air-to-open)	A									
		PSA1D Direct action (Air-to-close)	B									
		PSA2R Reverse action (Air-to-open)	C									
		PSA2D Direct action (Air-to-close)	D									
		PSA3R Reverse action (Air-to-open)	E									
		PSA3D Direct action (Air-to-close)	F									
		PSA4R Reverse action (Air-to-open)	G									
PSA4D Direct action (Air-to-close)	H											
X	Supply pressure and spring range	140 kPa {1.4 kgf/cm ² }, 20 to 98 kPa {0.2 to 1.0 kgf/cm ² }	1									
		160 kPa {1.6 kgf/cm ² }, 20 to 98 kPa {0.2 to 1.0 kgf/cm ² }	2									
		270 kPa {2.8 kgf/cm ² }, 80 to 240 kPa {0.8 to 2.4 kgf/cm ² }	3									
		390 kPa {4.0 kgf/cm ² }, 80 to 240 kPa {0.8 to 2.4 kgf/cm ² }	4									
		400 kPa {4.0 kgf/cm ² }, 200 to 340 kPa {2.0 to 3.5 kgf/cm ² }	5									
		260 kPa {2.6 kgf/cm ² }, 100 to 180 kPa {1.0 to 1.8 kgf/cm ² }	6									
XI	Painting	Standard: Blue (M10B5/10)	1									
		Silver	2									
		Heat resistant Silver	3									
		Corrosion resistant Silver	4									
		Saline-resistant Silver	5									
		Recommended: Bolt & nut material: SUS304	5									
Others	Body / Diaphragm case / yokes Enter client's requirement	9										

(Continued)

(Continued from previous page)

Optional selection

Option

XII	Manual hand wheel	No selection	X						
		Side hand wheel	S						
XIII	Positioner	No selection	X						
		Smart I/P	[AVP300]	C					
		Smart I/P (with motion transmitter)	[AVP301]	D					
		Smart I/P TIIS Flameproof type	[AVP300]	G					
		Smart I/P TIIS Flameproof type (with motion transmitter)	[AVP301]	H					
		Smart I/P remote type	[AVP200]	J					
		Smart I/P remote type (With motion transmitter)	[AVP201]	K					
		Smart I/P TIIS Flameproof type Remote type	[AVP200]	L					
		Smart I/P TIIS Flameproof type, Remote type (with motion transmitter)	[AVP201]	M					
		I/P JIS water-proof	[HEP17]	1					
		I/P TIIS flameproof	[HEP15]	2					
		Compact pneumatic type (PSA1 only)	[VPE]	5					
		Pneumatic type only	[HTP]	6					
Others	Enter client's request	9							
XIV	Combination filter and regulator	No selection	X						
		Yes (without pressure gauge) [KZ03] (for AVP, HEP, HTP)	1						
		Yes (with pressure gauge) [KZ03] (for VPE)	2						
		Others	Enter client's request	9					
XV	Solenoid valves	No selection	X						
		General purpose J320G174 (ASCO)	1						
		TIIS flameproof type JE3J320G174 (ASCO)	3						
		Others	Enter client's request	9					
XVI	Limit switch	No selection	X						
		Water-proof single mount	[VCL5001]	1					
		Water-proof dual mount	[VCL5001]	2					
		TIIS flameproof single mount	[VCX5001]	3					
		TIIS flameproof dual mount	[VCX5001]	4					
Others	Enter client's request	9							

No selection	X
Vinyl-sheathed copper tube + cap	A
Exposed bolts & nuts: SUS304 *2	B
Copper-free treatment (wetted part)	E
Others	9

* For [Others] in the additional specification check the following items

- Material certificates of body & bonnet.
- Strength calculation
- Air piping connection 1/4 inch NPT
- Flow characteristics inspection
- Radiographic test (RT)
- Liquid penetrant test (PT)

High-pressure gas regulation approval	Applicable fluid
	Gas type <input type="checkbox"/> Toxic gas <input type="checkbox"/> Flammable gas <input type="checkbox"/> Special HP. gas <input type="checkbox"/> Others
	Grade <input type="checkbox"/> Grade 1 <input type="checkbox"/> Grade 2 <input type="checkbox"/> Grade 3
	Design temperature deg.C
	Design pressure MPa kPa
Applicable plant name	

Note) *1 Applicable to stud bolts for body, bolts and nuts for hand wheel, accessories, and actuators

*2 Positioner action
Direct action: Increase pneumatic output when input signal increased.
Reverse action: Decreased pneumatic output when input signal increased.

*3 Output characteristics conversion
In case of "None", A to C shall be linear characteristics, and D to U shall be EQ% characteristics.
In case of "Yes", A to C shall be EQ% characteristics, and D to U shall be linear characteristics.
Those above conversion shall be made by POSITIONER.

*4 AVP position transmitting feature (model AVP301 only)
Four-wire connection is required when use position transmitting feature.

*5 DE: Digital signal common to YC group.
Plug and seat materials shall be SUS316 stellite face or SUS316L stellite seat when Cv values are 0.1 to 0.16 and 0.25.

Positioner	Input signal:	mA, kPa, kgf/cm ²	
	Change of action: <input type="checkbox"/> No (direct), <input type="checkbox"/> Yes (reverse) *2		
	Change of output characteristics: <input type="checkbox"/> No, <input type="checkbox"/> Yes *3		
	Position transmitting feature: (for model AVP301 only): <input type="checkbox"/> 4-20mA, <input type="checkbox"/> DE *4		
	Compression packings	HEP	<input type="checkbox"/> None, <input type="checkbox"/> 1 piece
TIIS flameproof	AVP	<input type="checkbox"/> No, <input type="checkbox"/> Yes	

Solenoid valves	Energize: <input type="checkbox"/> CV CONTROL, <input type="checkbox"/> CV CLOSE, <input type="checkbox"/> CV OPEN, <input type="checkbox"/> OTHERS	V	Hz
	De-energize: <input type="checkbox"/> CV CONTROL, <input type="checkbox"/> CV CLOSE, <input type="checkbox"/> CV OPEN, <input type="checkbox"/> OTHERS		
	Power supply <input type="checkbox"/> AC, <input type="checkbox"/> DC		

Limit switch	Operating position: <input type="checkbox"/> CLOSE, <input type="checkbox"/> OPEN, <input type="checkbox"/> OPEN&CLOSE, <input type="checkbox"/> OTHERS
	<input type="checkbox"/> Pressure-tight packing adaptor

Please fill in the blanks with the necessary information.

Process data	Fluid name				Slurry <input type="checkbox"/>
		MAX	NOR	MIN	Unit
	Flow rate				
	Upstream pressure				MPa. kPa
	Downstream pressure				MPa. kPa
	Differential pressure				MPa. kPa
	Differential pressure when fully closed				MPa. kPa
	Temperature				°C, °F
	Specific gravity				
	Viscosity				cP, cSt
Flashing %				%	
Calculated CV value					

Note

(Continued from previous page)

Optional selection

XII	Manual hand wheel	No selection	X
		Side mount	S
XIII	Positioner	No selection	X
		Smart I/P [AVP300]	C
		Smart I/P (with position Tx) [AVP301]	D
		Smart I/P TIIIS Flameproof type [AVP300]	G
		Smart I/P TIIIS Flameproof type (with motion transmitter) [AVP301]	H
		Smart I/P remote type [AVP200]	J
		Smart I/P remote type (With motion transmitter) [AVP201]	K
		Smart I/P TIIIS Flameproof type [AVP200]	L
		Remote type	
		Smart I/P TIIIS Flameproof type, Remote type (with motion transmitter) [AVP201]	M
		I/P JIS water-proof [HEP17]	1
		I/P TIIIS flameproof [HEP15]	2
		Compact pneumatic type (PSAI only) [VPE]	5
		Pneumatic Std type [HTP]	6
		Others	Enter client's requirement
XIV	Combination filter and regulator	No selection	X
		Yes (without pressure gauge) [KZ03] (for AVP, HEP, HTP)	1
		Yes (with pressure gauge) [KZ03] (for VPE)	2
		Others	Enter client's request
XV	Solenoid valves	No selection	X
		General purpose J320G174 (ASCO)	1
		TIIIS flameproof type JE3J320G174 (ASCO)	3
		Others	Enter client's requirement
XVI	Limit switch	No selection	X
		Water-proof single mount [VCL5001]	1
		Water-proof dual mount [VCL5001]	2
		TIIIS flameproof single mount [VCX5001]	3
		TIIIS flameproof dual mount [VCX5001]	4
		Others	Enter client's requirement

Option

No selection	X
Vinyl-sheathed copper tube + cap	A
Exposed bolts & nuts: SUS304 *1	B
Copper-free treatment (to process media)	E
Others	9

* For [Others] in the additional specification check the following items

- Material certificates of body & bonnet.
- Strength calculation
- Air piping connection 1/4 inch NPT
- Flow characteristics inspection
- Radiographic test (RT)
- Liquid penetrant test (PT)

High-pressure gas regulation approval	Applicable fluid
	Gas type <input type="checkbox"/> Toxic gas <input type="checkbox"/> Flammable gas <input type="checkbox"/> Special HP. gas <input type="checkbox"/> Others
	Grade <input type="checkbox"/> Grade 1 <input type="checkbox"/> Grade 2 <input type="checkbox"/> Grade 3
	Design temperature deg.C
	Design pressure MPa
	Applicable plant name

Note)

- *1 Applicable to stud bolts for body, bolts and nuts for hand wheel, accessories, and actuators
- *2 Positioner action
Direct action: Increase pneumatic output when input signal increased.
Reverse action: Decreased pneumatic output when input signal increased.
- *3 Output characteristics conversion
In case of "None", A to C shall be linear characteristics, and D to U shall be EQ% characteristics.
In case of "Yes", A to C shall be EQ% characteristics, and D to U shall be linear characteristics.
Those above conversion shall be made by POSITIONER.
- *4 AVP position transmitting feature (model AVP301 only)
Four-wire connection is required when use position transmitting feature.
DE: Digital signal common to YC group.
- *5 Plug and seat materials shall be SUS316 stellite face or SUS316L stellite seat when Cv values are 0.1 to 0.16 and 0.25.

Positioner	Input signal:	_____ mA, kPa, kgf/cm ²
	Change of action:	<input type="checkbox"/> No (direct), <input type="checkbox"/> Yes (reverse) *2
	Change of output characteristics:	<input type="checkbox"/> No, <input type="checkbox"/> Yes *3
	Position transmitting feature: (for model AVP301 only):	<input type="checkbox"/> 4-20mA, <input type="checkbox"/> DE *4
	Compression packings	HEP <input type="checkbox"/> None, <input type="checkbox"/> 1 piece
	TIIIS flameproof	AVP <input type="checkbox"/> No, <input type="checkbox"/> Yes

Solenoid valves	Energize: <input type="checkbox"/> CV CONTROL, <input type="checkbox"/> CV CLOSE, <input type="checkbox"/> CV OPEN, <input type="checkbox"/> OTHERS
	De-energize: <input type="checkbox"/> CV CONTROL, <input type="checkbox"/> CV CLOSE, <input type="checkbox"/> CV OPEN, <input type="checkbox"/> OTHERS
	Power supply <input type="checkbox"/> AC, <input type="checkbox"/> DC _____ V _____ Hz

Limit switch	Operating position: <input type="checkbox"/> CLOSE, <input type="checkbox"/> OPEN, <input type="checkbox"/> OPEN&CLOSE, <input type="checkbox"/> OTHERS
	<input type="checkbox"/> Pressure-tight packing adaptor

Please fill in the blanks with the necessary information.

Process data	Fluid name				Slurry <input type="checkbox"/>
		MAX	NOR	MIN	Unit
	Flow rate				
	Upstream pressure				MPa, kPa
	Downstream pressure				MPa, kPa
	Differential pressure				MPa, kPa
	Differential pressure when fully closed				MPa, kPa
	Temperature				°C, °F
	Specific gravity				
	Viscosity				cP, cSt
	Flashing %				%
Calculated CV value					

Note

Note

Note

Specifications are subject to change without notice.

azbil

Yamatake Corporation
Advanced Automation Company

1-12-2 Kawana, Fujisawa-shi
Kanagawa-ken 251-8522 Japan

URL:<http://www.azbil.com>

No part of this publication may be reproduced or duplicated without the prior written permission of Yamatake Corporation.

Jun. 1995-Y/Y
Jun. 2009 (rev.11)-Y/Y