

# CV3000 Series

## Pressure-Balanced Cage type Control Valve

### Model ACP

#### OVERVIEW

The model ACP pressure-balanced cage type control valve are designed for heavy duty service. The compact valve body, which features an S-shape flow passage that provides a minimal amount of pressure loss, allows a large flow capacity, rangeability, and high accuracy flow characteristics.

The valve plug employs a pressure balance function to control high differential pressure with small actuator force. The model ACP includes a seal ring and a scraper ring between the valve plug and the cage. The former reduces seat leakage and the latter keeps the sliding section clean and free of foreign substances.

Its simple design utilizes a compact yet powerful diaphragm actuator loaded with multiple springs.

The model ACP control valves are widely applicable for reliable control of small flows in high or low temperature, high pressure process lines.

#### SPECIFICATIONS

##### Body

###### Type

Straight-through, cast globe valve

###### Nominal size

1½, 2, 2½, 3, 4, 5, 6, 8 inches

###### Pressure rating

- JIS 10K, 16K, 20K, 30K, 40K
- ANSI Class 125, 150, 300, 600
- JPI Class 125, 150, 300, 600

###### End connection

- Flanged end; FF, RF, RJ, LG  
Tongue and groove type (groove)  
Male and female (female)
- Welded end; SW (1½, 2 inches), BW (2½ to 8 inches)

###### Material

For combining the valve body, trim materials and the operating temperature ranges, refer to Table 2.

###### Bonnet

- Plain bonnet (-17 to 230°C)
- Extension bonnet Type 1  
(230 to 360°C and -45 to -17°C)
- Extension bonnet Type 2  
Integral cast type (-100 to -45°C)  
Welded type (-196 to -100°C)

*Note) Take care not to exceed the operating temperature ranges specified for respective materials.*

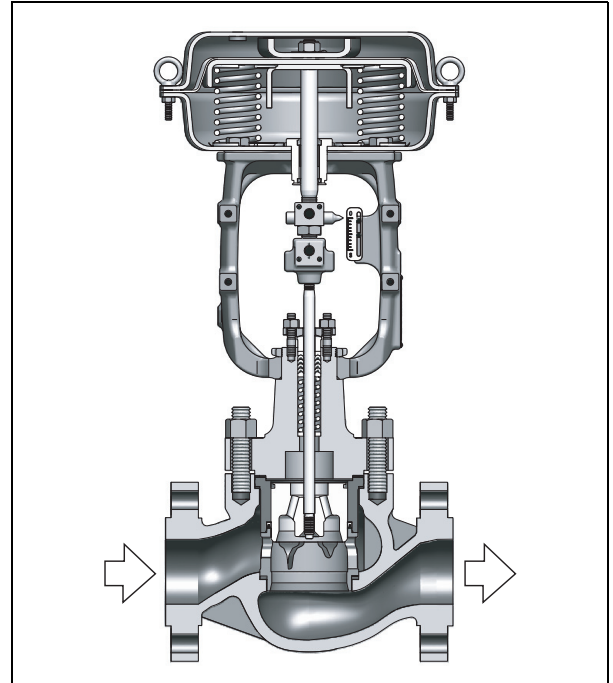

##### Gland type

Bolted gland

##### Packing/grease

- Grease not provided when V shaped PTFE\* packing or PTFE\* yarn packing is used.
- Grease provided when asbestos yarn, PTFE-impregnated asbestos yarn, asbestos yarn with graphite, or graphite packing is used.

*Note) PTFE: Polytetrafluoroethylene*

##### Gasket

	General / Low temp.	High temperature	Oil free treatment
Between body and bonnet	Metal gasket (PTFE coating) V543 (PTFE)	Metal gasket V543	Metal gasket (PTFE coating) V543 (PTFE)
For upper cage	Metal gasket (PTFE coating) V543 (PTFE)	Metal gasket V543	Metal gasket (PTFE coating) V543 (PTFE)
For bottom cage	Spiral-shaped gasket V8590	Not necessary	Spiral-shaped gasket V7590

**Trim**

**Valve plug**

Single seated pressure balanced type

**Cage**

- High-flow characteristics type
- Metal seat

(For flow characteristics, refer to Figure 2.)

Equal percentage cage (%V)

Linear cage (LV)

*Note) Integral cage and split cage vary depending on their valve sizes, materials, and operating temperature. Refer to Table 2.*

**Material**

For combining the valve body, trim materials and the operating temperature ranges, refer to Table 2.

*Note) For fluid conditions that require Stellite, refer to Figure 3.*

**Actuator**

**Type:** Single acting diaphragm actuator (Type HA)

**Action:** Direct or reverse action

**Diaphragm**

Type HA; Cloth embedded ethylene propylene rubber

**Spring range**

- 20 to 98 kPa {0.2 to 1.0 kgf/cm<sup>2</sup>}, or 80 to 240 kPa {0.8 to 2.4 kgf/cm<sup>2</sup>}

**Supply pressure**

Diaphragm actuator

Type HA; 140 to 390 kPa {1.4 to 4.0 kgf/cm<sup>2</sup>}

*Note) Allowable differential pressure varies depending on spring range and air supply pressure.*

**Air connection**

Rc1/4 or 1/4NPT internal thread

**Ambient temperature**

-30 to 70 °C

**Valve action**

Air-to-close (Direct action actuator is combined.)

Air-to-open (Reverse action actuator is combined.)

**Optional accessories (provided upon request)**

Positioner\*, pressure regulator with filter, handwheel\*, limit switch, solenoid valve, motion transmitter, booster relay, air lock-up valve, and others.

*Note 1) For optional items, refer to the specification sheets and installation drawings of the respective accessories.*

*2) Accessories with the asterisk mark (\*) are selected from among the following types depending on the actuators to be combined.*

**Table 1 Combination for accessories**

Actuator	Positioner		Manual handwheel	
	P/P	I/P	Top	Side
HA2 to 4	HTP	HEP/AVP	THM	SHM

**Additional specifications (by special order)**

- Special inspection
- Flow characteristics inspection, material inspection (Material certificate), non-destructive inspection, steam inspection, low-temperature inspection
- Seat chamfered flange
- Double gland
- Copper free treatment
- Stainless steel (SUS304) atmospheric-exposed nuts and bolts
- Yoke material SCPH2
- Sand-/dust preventive measure
- Saline damage countermeasure
- Cold-area use specification
- Tropical-area use specification
- With drain plug
- Oil/water free treatment
- Special air piping and joint
- Vacuum service

**Performance**

**Rated Cv value**

Refer to Table 3 and 4.

**Flow characteristics**

Refer to Figure 2.

**Inherent range ability**

50 : 1 (Optional 75 : 1)

**Allowable differential pressure**

Refer to Table 5 and 6. (temperature range: -196 to 230°C)

Refer to Table 7 and 8. (temperature range: 230 to 360°C)

**Leakage rate specification**

IEC 534-4-1986 and JIS B2007-1993.

Class IV: Leakage less than 0.01%

**Hysteresis error**

Without positioner: Within 3% F.S.

With positioner: Within 1% F.S.

**Linearity**

Without positioner: Within ±5% F.S.

With positioner: Within ±1% F.S.

*Note) When positioner is not provided, operating performance may vary depending on type of packing used.*

**Dimensions**

Refer to Figure 4, Table 9 and Table 10.

**Weight**

Refer to Table 11.

**Actuator orientation**

Refer to Figure 5.

**Finish**

Blue (Munsell 10B5/10) or silver, or their specified colors.

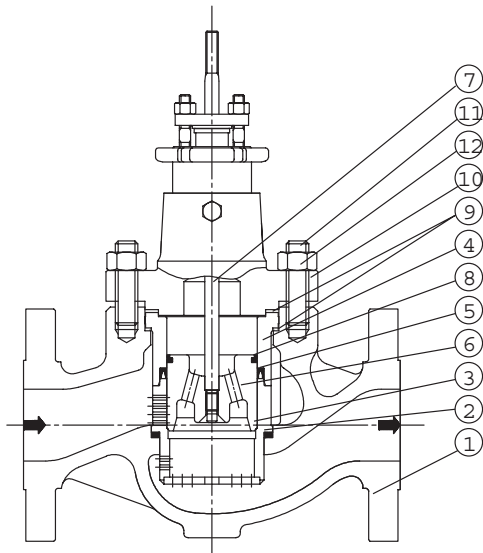

No.	Parts name
1	Valve body
2	Spiral gasket
3	Bottom cage
4	Upper cage
5	Seal ring
6	Valve plug
7	Valve stem
8	Scraper ring
9	Serrated gasket
10	Bonnet
11	Stud bolt
12	Hex nut

Figure 1-1 Model ACP structure drawing (temperature range: -196 to 230°C)

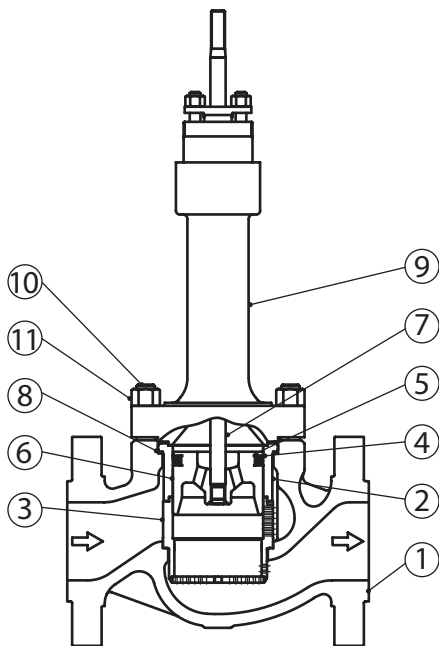

No.	Parts name
1	Valve body
2	Upper cage
3	Bottom cage
4	Seal ring (carbon)
5	Expander spring (Inconel X-750)
6	Plug
7	Valve stem
8	Serrated gasket
9	Bonnet
10	Stud bolt
11	Hex nut

Figure 1-2 Model ACP structure drawing (temperature range: +230 to +360°C)

Table 2 Combining the valve body, trim materials and operating temperature range (°C)

Body material		JIS	FC200	SCPH2	SCPH21	SCS61	SCPL1	SCS13A	SCS14A
		ASTM	A126Gr.B	A216WCB	A217WC6	A217C5	A352LCB	A351CF8	A351CF8M
ASTM	A351CF8M*		0 to 200	-5 to 230	-5 to 230	-5 to 230	-45 to 230	-196 to 230	-196 to 230
ASTM	A351CF8M* Stellite		-	-5 to 360	-5 to 360	-5 to 360	-45 to 350	-196 to 360	-196 to 360

Note) A351CF8M: JIS SCS14A equivalent

**Cv value and travel**

**Table 3 CV value and travel (temperature range: -196 to 230°C)**

Nominal size (inches)	1 ½			2			2 ½			3			4			5			6			8		
Port size (inches)	1	1¼	1½	1¼	1½	2	1½	2	2½	2	2½	3	2½	3	4	3	4	5	4	5	6	5	6	8
Rated Cv (%V)	10	26	29	18	31	56	23	40	78	59	78	110	63	103	158	99	175	250	179	261	322	275	360	610
Rated Cv (LV)	-	-	34	-	-	60	-	-	81	-	-	115	-	-	203	-	-	250	-	-	371	-	-	795
Rated travel (mm)	25						38						50						75					

**Table 4 Cv value and travel (temperature range: +230 to +360°C)**

Nominal size (inches)	1 ½			2			2 ½			3			4			5			6			8		
Port size (inches)	1	1¼	1½	1¼	1½	2	1½	2	2½	2	2½	3	2½	3	4	3	4	5	4	5	6	5	6	8
Rated Cv (LV)	-	-	24	-	-	52	-	-	78	-	-	110	63	103	150	99	175	250	179	261	350	275	360	600
Rated travel (mm)	25						38						50						75					

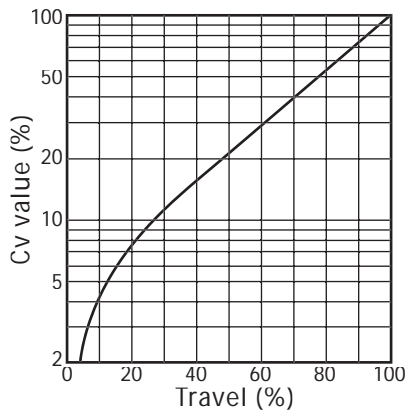

Equal percentage characteristics (%V)

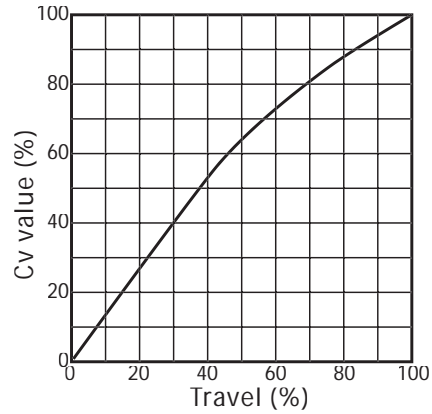

Linear characteristics (LV)

**Figure 2 Flow characteristics**

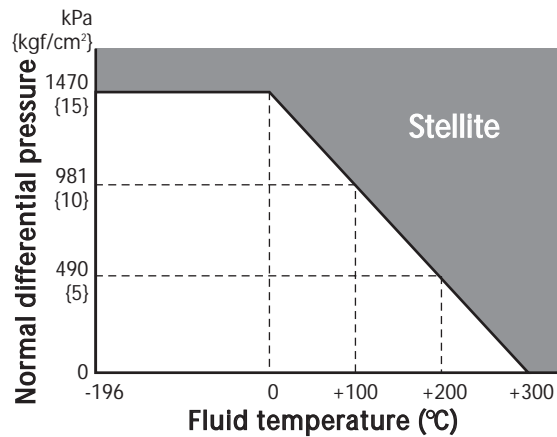
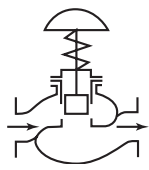

**Figure 3 Temperature / normal differential pressure ranges requiring Stellite**

Note) For cavitation / flashing service or oil free service, Stellite is recommended regardless of temperature and differential pressure.

**Allowable differential pressure (Temperature range: -196 to 230°C)**

**Table 5 Air-to-close**



Actuator Model No.	Supply pressure kPa {kgf/cm <sup>2</sup> }	Spring range kPa {kgf/cm <sup>2</sup> }	Positioner	Differential pressure (by nominal size (inches)) kPa {kgf/cm <sup>2</sup> }							
				1½	2	2½	3	4	5	6	8
HA2D	140 {1.4}	20 to 98 {0.2 to 1.0}	△	3920 {40.0}	2300 {23.5}	1310 {13.4}	540 {5.5}	—	—	—	—
				3950 {40.3}	2300 {23.5}	1310 {13.4}	540 {5.5}	—	—	—	—
	160 {1.6}	20 to 98 {0.2 to 1.0}	○	3920 {40.0}	3920 {40.0}	3760 {38.3}	2720 {27.8}	1240 {12.6}	—	—	—
				7900 {80.6}	5380 {54.9}	3920 {40.0}	2720 {27.8}	1240 {12.6}	—	—	—
	390 {4.0}	80 to 240 {0.8 to 2.4}	○	—	3920 {40.0}	3920 {40.0}	3920 {40.0}	3920 {40.0}	—	—	—
				—	9810 {100.0}	9810 {100.0}	9810 {100.0}	9810 {100.0}	—	—	—
HA3D	140 {1.4}	20 to 98 {0.2 to 1.0}	△	3920 {40.0}	3920 {40.0}	3920 {40.0}	2890 {29.5}	1470 {15.0}	—	—	—
				8760 {89.3}	6810 {69.4}	4640 {47.3}	2890 {29.5}	1470 {15.0}	—	—	—
	160 {1.6}	20 to 98 {0.2 to 1.0}	○	3920 {40.0}	3920 {40.0}	3920 {40.0}	3920 {40.0}	3920 {40.0}	2050 {20.9}	1560 {15.9}	—
				9810 {100.0}	9810 {100.0}	9280 {94.6}	6750 {68.8}	4400 {44.9}	2050 {20.9}	2070 {21.1}	—
	390 {4.0}	80 to 240 {0.8 to 2.4}	○	—	—	—	—	3920 {40.0}	3920 {40.0}	3920 {40.0}	—
				—	—	—	—	9810 {100.0}	9810 {100.0}	9810 {100.0}	—
HA4D	140 {1.4}	20 to 98 {0.2 to 1.0}	△	—	—	—	—	3920 {40.0}	2660 {27.1}	1900 {19.4}	1020 {10.4}
				—	—	—	—	5070 {51.7}	2660 {27.1}	2680 {27.3}	1450 {14.8}
	160 {1.6}	20 to 98 {0.2 to 1.0}	○	—	—	—	—	3920 {40.0}	3920 {40.0}	3450 {35.2}	2280 {23.2}
				—	—	—	—	9810 {100.0}	6210 {63.3}	6250 {63.7}	4360 {44.5}
	390 {4.0}	80 to 240 {0.8 to 2.4}	○	—	—	—	—	—	—	—	3920 {40.0}
				—	—	—	—	—	—	—	9810 {100.0}

**Table 6 Air-to-open**

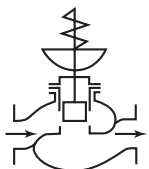

Actuator Model No.	Supply pressure kPa {kgf/cm <sup>2</sup> }	Spring range kPa {kgf/cm <sup>2</sup> }	Positioner	Differential pressure (by nominal size (inches)) kPa {kgf/cm <sup>2</sup> }							
				1½	2	2½	3	4	5	6	8
HA2R	140 {1.4}	20 to 98 {0.2 to 1.0}	△	—	—	—	—	—	—	—	—
				3920 {40.0}	3920 {40.0}	3920 {40.0}	3920 {40.0}	2840 {29.0}	—	—	—
	270 {2.8}	80 to 240 {0.8 to 2.4}	○	9810 {100.0}	8450 {86.2}	6540 {66.7}	4890 {49.9}	2890 {29.5}	—	—	
HA3R	140 {1.4}	20 to 98 {0.2 to 1.0}	△	1750 {17.8}	1360 {13.9}	—	—	—	—	—	—
				1750 {17.8}	1360 {13.9}	—	—	—	—	—	—
	270 {2.8}	80 to 240 {0.8 to 2.4}	○	—	3920 {40.0}	3920 {40.0}	3920 {40.0}	3920 {40.0}	3920 {40.0}	2460 {25.1}	—
				—	9810 {100.0}	9810 {100.0}	9810 {100.0}	7340 {74.8}	4110 {41.9}	4140 {42.2}	—
HA4R	140 {1.4}	20 to 98 {0.2 to 1.0}	△	—	—	—	—	—	—	—	—
				—	—	—	—	3920 {40.0}	3920 {40.0}	3920 {40.0}	3540 {36.1}
270 {2.8}	80 to 240 {0.8 to 2.4}	○	—	—	—	—	—	9810 {100.0}	9750 {99.4}	9810 {100.0}	7270 {74.1}
			—	—	—	—	—	—	—	—	

Note 1) "□" shows standard combination of valve body and trim materials

2) ○: Positioner is necessary. △: Can be operated either with or without positioner.

3) Take care not to cause the maximum allowable differential pressure to exceed the maximum operating pressure designated by ANSI B16.34-1981 or JIS B2201-1984.

4) The upper figures denote the allowable differential pressure for operation; the lower denote allowable differential pressure at full closure.

**Allowable differential pressure (temperature range: 230 to 360°C)**

Table 7 Air-to-close

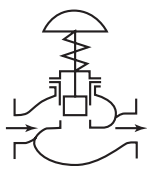

Actuator model No.	Supply pressure kPa{kgf/cm <sup>2</sup> }	Spring range kPa{kgf/cm <sup>2</sup> }	Positioner	Differential pressure (by nominal size (inches)) kPa {kgf/cm <sup>2</sup> }								
				1½	2	2½	3	4	5	6	8	
HA3D	390 {4.0}	80 to 240 {0.8 to 2.4}	○	3920 {40.0}	3920 {40.0}	3920 {40.0}	3920 {40.0}	3920 {40.0}	3920 {40.0}	3920 {40.0}	3920 {40.0}	—
				9810 {100.0}	9810 {100.0}	9810 {100.0}	9710 {99.0}	9490 {96.8}	9780 {99.7}	5280 {53.8}	—	
HA4D	390 {4.0}	80 to 240 {0.8 to 2.4}	○	—	—	—	—	3920 {40.0}	3920 {40.0}	3920 {40.0}	3920 {40.0}	—
				—	—	—	—	9810 {100.0}	9810 {100.0}	9180 {93.6}	7140 {72.8}	

Table 8 Air-to-open

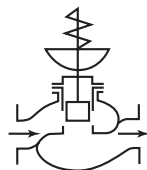

Actuator model No.	Supply pressure kPa{kgf/cm <sup>2</sup> }	Spring range kPa{kgf/cm <sup>2</sup> }	Positioner	Differential pressure (by nominal size (inches)) kPa {kgf/cm <sup>2</sup> }							
				1½	2	2½	3	4	5	6	8
HA3R	390 {4.0}	80 to 240 {0.8 to 2.4}	○	3920 {40.0}	3920 {40.0}	3880 {39.6}	3500 {35.7}	3920 {40.0}	3920 {40.0}	2220 {22.6}	—
				6470 {66.0}	5020 {51.2}			4200 {42.8}	4110 {41.9}		—
HA4R	390 {4.0}	80 to 240 {0.8 to 2.4}	○	—	—	—	—	3920 {40.0}	3920 {40.0}	3900 {39.8}	3030 {30.9}
				—	—	—	—	6910 {70.4}	6910 {70.4}		

- Note) 1. "□" shows standard combination of valve body and trim materials  
 2. ○: Positioner is necessary. △: Can be operated either with or without positioner.  
 3. Take care not to cause the maximum allowable differential pressure to exceed the maximum operating pressure designated by ANSI B16. 34-1981 or JIS B2201-1984.  
 4. The upper figures denote the allowable differential pressure for operation; the lower denote allowable differential pressure at full closure.

**DIMENSIONS**

Table 9 Face-to-face dimensions

[Unit: mm]

Nominal size (inches)	A							
	JIS 10KRF, RF ANSI 125FF ANSI 150RF JPI 150RF	JIS 16KRF	JIS 20KRF JIS 30KRF ANSI 300RF JPI 300RF	JIS 40KRF ANSI 600RF JPI 600RF	JIS 16K Tongue and groove Male & female	JIS 20K Tongue and groove Male & female	JIS 30K Tongue and groove Male & female	JIS 40K Tongue and groove Male & female
1½	222	231	235	251	235	236	248	251
2	254	263	267	286	265	267	276	286
2½	276	288	292	311	290	292	303	311
3	298	313	317	337	310	317	326	337
4	352	364	368	394	360	368	379	394
5	403	425	425	457	—	—	—	—
6	451	465	473	508	475	473	486	508
8	543	560	568	610	570	568	580	610

Nominal size (inches)	A							
	ANSI 150RJ JPI 150RJ	ANSI 300RJ JPI 300RJ	ANSI 600RJ JPI 600RJ	ANSI 300LG JPI 300LG	ANSI 600LG JPI 600LG	ANSI 150 JPI 150 SW, BW	ANSI 300 JPI 300 SW, BW	ANSI 600 JPI 600 SW, BW
1½	235	248	251	244	248	251	251	251
2	267	283	289	276	283	286	286	286
2½	289	308	314	302	308	311	311	311
3	311	333	340	327	333	337	337	337
4	365	384	397	378	391	394	394	396
5	416	441	460	441	460	425	425	457
6	464	489	511	483	505	473	508	508
8	556	584	613	578	606	568	610	610

Note) Face-to-face dimensions conform to IEC534-3-1976 Specifications.

**DIMENSIONS**

**Table 10 External dimensions**

[Unit: mm]

Nominal size (inches)	Actuator Model No.	H				B	φB	E
		Plain bonnet	Extension bonnet type 1	Extension bonnet Type 2				
				Integral cast type	Welded type			
1 ½	HA2D, R	500	665	780	1020	281	267	70
	HA3D, R	590	765	875	1140	363	350	
2	HA2D, R	500	670	785	1025	281	267	80
	HA3D, R	595	765	875	1140	363	350	
2 ½	HA2D, R	575	745/755	880	1130	281	267	90
	HA3D, R	630	800/810	930	1180	363	350	
3	HA2D, R	580	755/765	900	1135	281	267	100
	HA3D, R	635	810/820	955	1190	363	350	
4	HA2D, R	610	810/820	915	1150	281	267	115
	HA3D, R	660	860/870	1020	1205	363	350	
	HA4D, R	890	1100/1110	1255	1520	520	470	
5	HA3D, R	775	925	1265	1365	363	350	141
	HA4D, R	945	1095	1435	1535	520	470	
6	HA3D, R	785	1020/1045	1250	1385	363	350	170
	HA4D, R	955	1190/1215	1425	1570	520	470	
8	HA4D, R	1090	1350	1580	1710	—	470	220

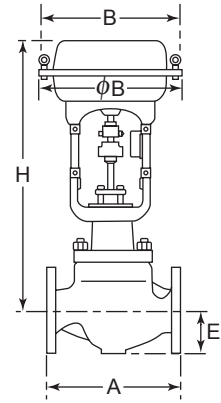
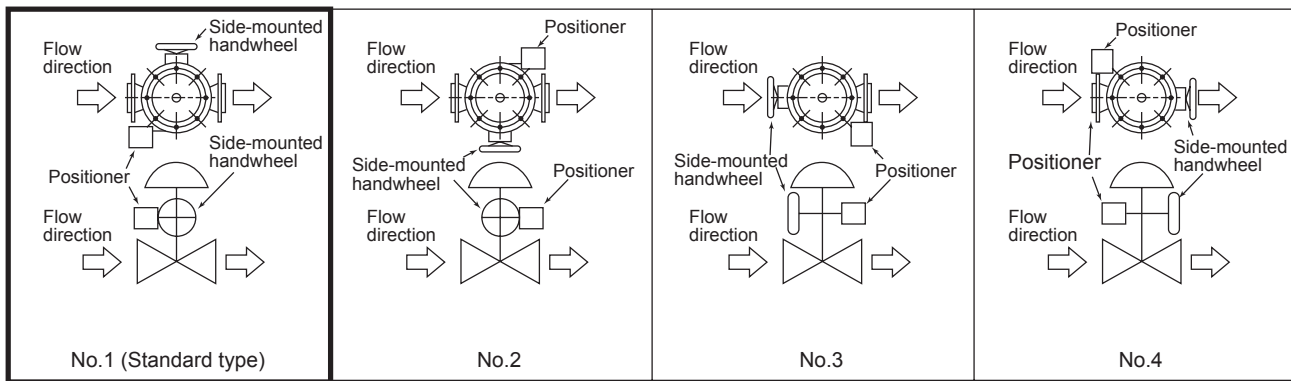

**Figure 4 Face-to-face and other dimensions**

**Table 11 Weight**

[Unit: kg]

Nominal size (inches)	Actuator model no.	Weight															
		Flange type JIS 10K, ANSI/JPI150				Flange type JIS 16K, 20K, 30K, ANSI/JPI 300				Flange type JIS 40K, ANSI/JPI 600				Welded type JIS 10K, 16K, 20K, 30K, ANSI/JPI 150, 300, 600			
		Plain bonnet	Extension Type 1 Bellows type		Extension Type 2		Plain bonnet	Extension Type 1 Bellows type		Extension Type 2		Plain bonnet	Extension Type 1 Bellows type		Extension Type 2		
			Integral cast type	Welded type	Integral cast type	Welded type		Integral cast type	Welded type	Integral cast type	Welded type						
1 ½	HA2R,R	31	34	37	39	36	39	42	44	44	47	50	52	36	39	42	44
	HA3D,R	43	46	49	51	48	51	54	56	56	59	62	64	64	51	54	56
2	HA2D,R	37	40	43	45	42	45	48	50	47	50	53	55	42	45	48	50
	HA3D,R	49	52	55	57	54	57	60	62	59	62	65	67	54	57	60	62
2 ½	HA2D,R	43	47	51	53	48	52	56	58	65	69	73	75	48	52	56	58
	HA3D,R	55	59	63	65	60	64	68	70	77	81	85	87	60	64	68	70
3	HA2D,R	53	59	65	68	63	69	75	78	85	91	97	100	63	69	75	78
	HA3D,R	65	71	77	80	75	81	87	90	97	103	109	112	75	81	87	90
4	HA2D,R	63	73	78	81	78	88	93	96	113	123	128	131	75	85	90	93
	HA3D,R	75	85	90	93	90	100	105	108	125	135	140	143	87	97	102	105
	HA4D,R	106	116	121	124	121	131	136	139	156	166	171	174	118	128	133	136
5	HA3D,R	132	140	154	157	142	150	164	167	187	195	209	212	135	143	157	160
	HA4D,R	168	176	190	193	178	186	200	203	223	231	245	258	168	179	190	193
6	HA3D,R	157	172	179	182	187	202	209	212	237	252	259	262	177	192	199	202
	HA4D,R	188	203	210	213	218	233	240	243	268	283	290	293	208	223	230	233
8	HA4D,R	268	288	298	303	318	338	348	353	438	458	468	473	308	328	338	343



**Figure 5 Actuator orientation**

Note) Indicated by position number when installation other than by the standard type is required.

### Ordering Information

When ordering, please specify;

- |   |  |
|---|--|
| 1) Model Number: ACP  | 10) Special requirement of degreasing, free from copper and etc.                                   |
| 2) Nominal size X Port size                                     | 11) Name of flow medium  |
| 3) Type and rating of end connections                           | 12) Normal flow and maximum required flow  |
| 4) Body and trim material, necessity of hardening               | 13) Pressure of flow medium upstream and downstream pressure at maximum and minimum, required flow |
| 5) Type of bonnet   | 14) Temperature and specific gravity of flow medium  |
| 6) Valve and plug characteristics                               | 15) Viscosity of flow medium, inclusive or exclusive of slurry                                     |
| 7) Type of actuator, air to diaphragm                           |  |
| 8) Valve action (direct or reverse)                             |  |
| 9) Accessories (positioner, handwheel, pressure regulator etc.) |  |

**azbil**

**Yamatake Corporation**  
Advanced Automation Company

1-12-2 Kawana, Fujisawa  
Kanagawa 251-8522 Japan

URL: <http://www.azbil.com>