

CV3000 Series

Low-Noise Cage type Control Valve

Model ACN

OVERVIEW

The model ACN low-noise cage type control valves are designed to reduce acoustic noise in services of compressible fluids such as steam, air and natural gas.

The cage employs multi-hole structure and reduce noise by ideal pressure reduction with a combination in two steps of "restriction" and "diffusion and expansion"

The valve plug employs a pressure balance function to control high differential pressure fluid with small actuator force.

The ACN realizes seat leakage performance as single seat valve by seal-ring structure.

In addition, the ACN is equipped the cage plug with a scraper ring to prevent a malfunction caused by foreign object enter between the cage plug and the cage.

The ACN is widely applicable for reliable control of high or low temperature, high differential pressure process lines where dynamic stability, low noise are required.

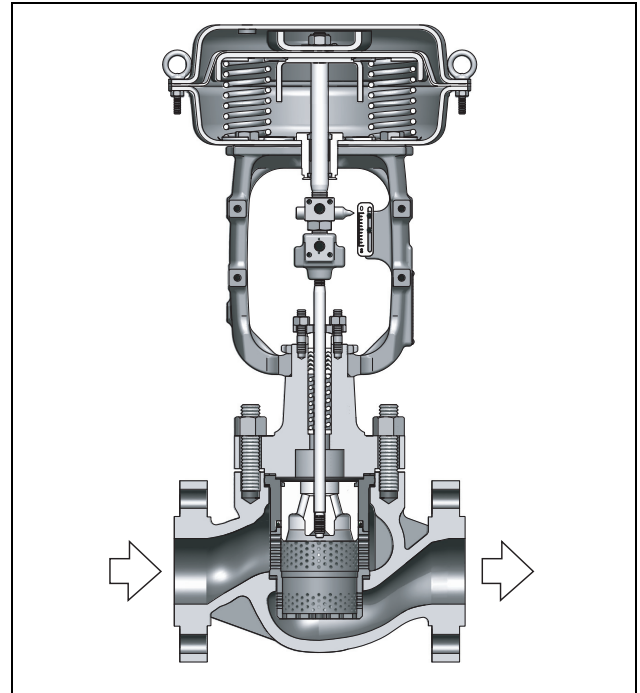

SPECIFICATIONS

Body

Type

Straight-through, cast globe valve

Nominal size

1½, 2, 2½, 3, 4, 5, 6, 8 inches

Pressure rating

- JIS 10K, 16K, 20K, 30K, 40K
- ANSI Class 125, 150, 300, 600
- JPI Class 125, 150, 300, 600

End connection

- Flanged end;

Connection type	Pressure rating	Applicable standard
FF	JIS10K	JIS B2210-1984
	ANSI Class 125	ANSI B16.5-1981
	JPI Class 125	JPI-7S-15-1993
RF	JIS10K, 16K, 20K, 30K, 40K	JIS B2210-1984
	ANSI Class 150, 300, 600	ANSI B16.5-1981
	JPI Class150, 300, 600	JPI-7S-15-1993
RJ, LG	ANSI Class 150, 300, 600	ANSI B16.5-1981
	JPI Class 150, 300, 600	JPI-7S-15-1993
Tongue and groove(groove) Male and female(female)	JIS16K, 20K, 30K, 40K	JIS B2202-1984

- Welded end; SW (1½, 2 inches), BW (2½ to 8 inches)

Material

For body/trim material combinations and operating temperature ranges, refer to Table 1.

Bonnet

- Plain bonnet (-17 to 230°C)
- Extension bonnet Type 1 (-45 to -17°C and 230 to 360°C)
- Extension bonnet Type 2
Integral cast type (-100 to -45°C),
Welded type (-196 to -100°C)

Note) Take care not to exceed the operating temperature ranges specified for respective materials.

Gland type

Bolted gland

Packing / Grease

- Grease not provided
When V shaped PTFE packing or PTFE yarn packing is used.
- Grease provided
When graphite packing is used.

Gasket

	General / Low temp.	High temperature	Oil free treatment
Between body and bonnet	Serrated gasket V543	Serrated gasket V543	Serrated gasket (PTFE coating) V543 (PTFE)
For upper cage	Serrated gasket V543	Serrated gasket V543	Serrated gasket (PTFE coating) V543 (PTFE)
For bottom cage	Spiral wound gasket V8590	Not necessary	Spiral wound gasket V7590

Trim

Valve plug

Single seated pressure balanced type

Cage

Multiple-orifice design

-Linear cage (LV)

(For flow characteristics, refer to Figure 2.)

Material

For body/trim material combinations and operating temperature ranges, refer to Table 1.

Note) For fluid conditions that require Stellite, refer to Figure 3.

Actuator

Type

Single acting diaphragm actuator (Type HA)

Action

Direct or reverse action

Diaphragm

Type HA: Cloth embedded ethylene propylene rubber

Spring range

20 to 98 kPa {0.2 to 1.0 kgf/cm²}

80 to 240 kPa {0.8 to 2.4 kgf/cm²}

Supply pressure

Diaphragm actuator

Type HA: 140 to 390 kPa {1.4 to 4.0 kgf/cm²}

Note) Allowable differential pressure varies depending on spring range and air supply pressure.

Air connection

Rc1/4 or 1/4NPT internal thread

Ambient temperature

-30 to 70°C

Valve action

Air-to-close (Direct action actuator is combined.)

Air-to-open (Reverse action actuator is combined.)

Optional accessories

Positioner*, pressure regulator with filter, hand wheel*, limit switch, solenoid valve, motion transmitter, booster relay, lock-up valve, and others.

Note) 1. For optional items, refer to the specification sheets and installation drawings of the respective accessories.

2. Accessories with the asterisk mark (*) are selected from among the following types depending on the actuators to be combined.

Actuator	Positioner		Hand wheel	
	P/P	I/P	Top	Side
HA2 to 4	HTP	AVP/HEP	THM	SHM

Additional specifications (by special order)

- Special inspection
Flow characteristics inspection, material inspection (Material certificate), non-destructive inspection, steam inspection, low-temperature inspection
- With drain plug
- Double gland
- Copper free treatment
- Stainless steel (SUS304) atmospheric-exposed nuts and bolts
- Special air piping and joint
- Sand-/dust preventive measure
- Saline damage countermeasure
- Cold-area use specification
- Tropical-area use specification
- Oil/water free treatment
- Vacuum service

Performance

Rated Cv value

Refer to Table 2 and 3.

Flow characteristics

Refer to Figure 2.

Inherent rangeability

- 50 : 1
- Optional 75 : 1 for full port size

Allowable differential pressure

Refer to Table 4 and 5. (temperature range: -196 to 230°C)

Refer to Table 6 and 7. (temperature range: 230 to 360°C)

Leakage specification

IEC 60534-4:2006 or JIS B 2005-4:2008

Class IV: Leakage less than 0.01% of maximum valve capacity.

Refer to following table about combination of port size and seat leakage specification.

Operating temperature	Nominal size (inches)	Port size	Seat leakage
-196 to 230 °C	1½ to 8	Full	Class IV : 0.01% of Cv value
		Reduced	
230 to 360 °C	1½, 2	Full	0.05% of Cv value
		Reduced	-
	2½, 3	Full	Class IV : 0.01% of Cv value
		Reduced	-
	4 to 8	Full	Class IV : 0.01% of Cv value
		Reduced	

Hysteresis error

Without positioner: Within 3% F.S.

With positioner Within 1% F.S.

Linearity

Without positioner: Within ± 5% F.S.

With positioner: Within ± 1% F.S.

Note) When positioner is not provided, operating performance may vary depending on type of packing used.

Dimensions

Refer to Figure 4, Table 8 and Table 9.

Weight

Refer to Table 10.

Actuator orientation

Refer to Figure 5.

Finish

Blue (Munsell 10B5/10) or silver, or their specified colors.

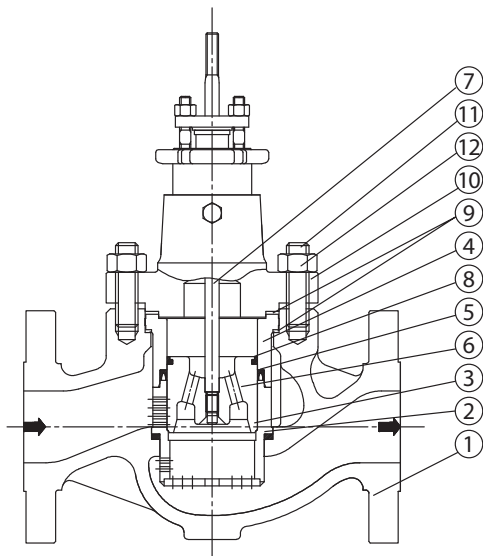

No.	Parts name
1	Valve body
2	Spiral wound gasket
3	Bottom cage
4	Upper cage
5	Seal ring
6	Valve plug
7	Valve stem
8	Scraper ring
9	Serrated gasket
10	Bonnet
11	Stud bolt
12	Hex nut

Figure 1-1 Model ACN structure drawing (temperature range: -196 to 230°C)

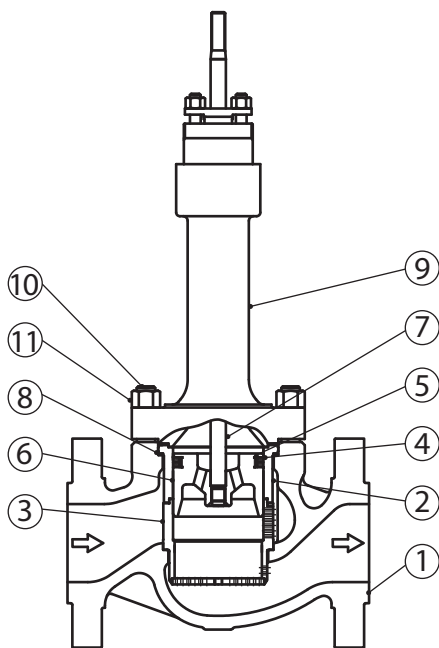

No.	Parts name
1	Valve body
2	Upper cage
3	Bottom cage
4	Seal ring (carbon)
5	Expander spring (Inconel X-750)
6	Plug
7	Valve stem
8	Serrated gasket
9	Bonnet
10	Stud bolt
11	Hex nut

Figure 1-2 Model ACN structure drawing (temperature range: +230 to +360°C)

Table 1 Body / trim material combinations and operating temperature ranges (°C)

Body material \ Trim material	JIS	FC200	SCPH2	SCPH21	SCS61	SCPL1	SCS 13A	SCS14A
	ASTM	A126Gr.B	A216WCB	A217WC6	A217C5	A352LCB	A351CF8	A351CF8M
ASTM A351CF8M		0 to 200	-5 to 230	-5 to 230	-5 to 230	-45 to 230	-196 to 230	-196 to 230
ASTM A351CF8M /SUS316 Stellite		-	-5 to 360	-5 to 360	-5 to 360	-45 to 350	-196 to 360	-196 to 360

Cv value and travel

Table 2 Cv value and travel (temperature range: -196 to 230°C)

Nominal size (inches)	1 ½			2			2 ½			3			4			5			6			8		
Port size (inches)	1	1¼	1½	1¼	1½	2	1½	2	2½	2	2½	3	2½	3	4	3	4	5	4	5	6	5	6	8
Rated Cv value (LV)	11	17	24	17	24	44	24	44	68	44	68	99	68	99	120	54	96	150	120	175	330	175	330	580
Rated travel (mm)	25						38						50						75					

Table 3 Cv value and travel (temperature range: +230 to +360°C)

Nominal size (inches)	1 ½			2			2 ½			3			4			5			6			8		
Port size (inches)	1	1¼	1½	1	1½	2	1½	2	2½	2	2½	3	2½	3	4	3	4	5	4	5	6	5	6	8
Rated Cv value (LV)	-	-	24	-	-	44	-	-	68	-	-	99	68	99	120	54	96	150	120	175	330	175	330	580
Rated travel (mm)	25						38						50						75					

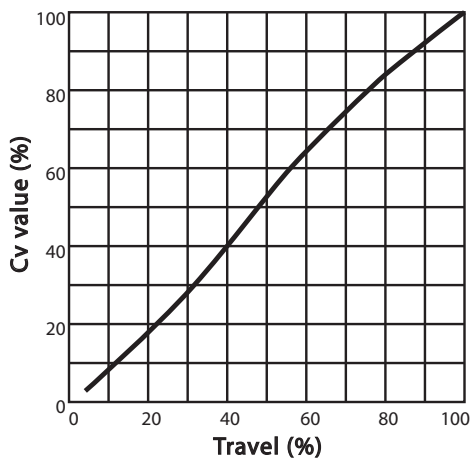

Figure 2 Flow characteristics

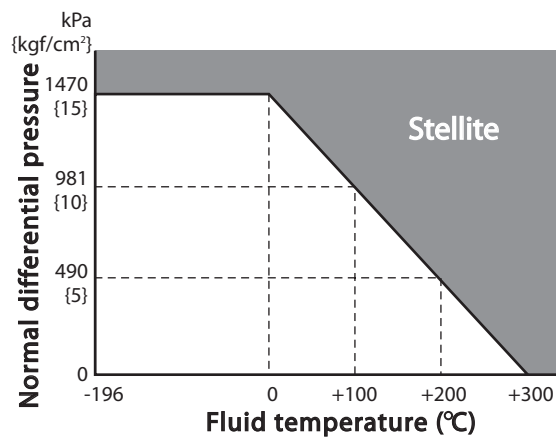

Figure 3 Temperature / normal differential pressure ranges requiring Stellite

Note) For cavitation / flashing service or oil prohibitive service, Stellite is recommended regardless of temperature and differential pressure.

Allowable differential pressure (temperature range: -196 to 230°C)

Metal seat (LV) : PTFE packing

Table 4 Air-to-close

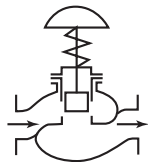

Actuator model No.	Supply pressure kPa{kgf/cm ² }	Spring range kPa{kgf/cm ² }	Positioner	Differential pressure (by nominal size (inches)) kPa {kgf/cm ² }							
				1½	2	2½	3	4	5	6	8
HA2D	140 {1.4}	20 to 98 {0.2 to 1.0}	△	3920	2300	1310	540	—	—	—	—
				{40.0}	{23.5}	{13.4}	{5.5}	—	—	—	—
				3950	2300	1310	540	—	—	—	—
	160 {1.6}	20 to 98 {0.2 to 1.0}	✓	7900	5380	3920	2820	1240	—	—	—
				{80.6}	{54.9}	{40.0}	{28.8}	{12.6}	—	—	—
				3920	3920	3760	2820	1240	—	—	—
	390 {4.0}	80 to 240 {0.8 to 2.4}	✓	—	3920	3920	3920	3920	—	—	—
				—	{40.0}	{40.0}	{40.0}	{40.0}	—	—	—
				—	9810	9810	9810	9810	—	—	—
HA3D	140 {1.4}	20 to 98 {0.2 to 1.0}	△	3920	3920	3920	2890	1470	—	—	—
				{40.0}	{40.0}	{40.0}	{29.5}	{15.0}	—	—	—
				8760	6810	4640	2890	1470	—	—	—
	160 {1.6}	20 to 98 {0.2 to 1.0}	✓	3920	3920	3920	3920	3920	2050	1560	—
				{40.0}	{40.0}	{40.0}	{40.0}	{40.0}	{20.9}	{15.9}	—
				9810	9810	9280	6750	4400	2050	2070	—
	390 {4.0}	80 to 240 {0.8 to 2.4}	✓	—	—	—	—	3920	3920	3920	—
				—	—	—	—	{40.0}	{40.0}	{40.0}	—
				—	—	—	—	9810	9810	9810	—
HA4D	140 {1.4}	20 to 98 {0.2 to 1.0}	△	—	—	—	—	3920	2660	1900	1020
				—	—	—	—	{40.0}	{27.1}	{19.4}	{10.4}
				—	—	—	—	5070	2660	2680	1450
	160 {1.6}	20 to 98 {0.2 to 1.0}	✓	—	—	—	—	3920	3920	3450	2280
				—	—	—	—	{40.0}	{40.0}	{35.2}	{23.2}
				—	—	—	—	9810	6210	6250	4360
	390 {4.0}	80 to 240 {0.8 to 2.4}	✓	—	—	—	—	—	—	—	3920
				—	—	—	—	—	—	—	{40.0}
				—	—	—	—	—	—	—	9810

Table 5 Air-to-open

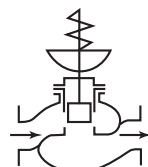

Actuator model No.	Supply pressure kPa{kgf/cm ² }	Spring range kPa{kgf/cm ² }	Positioner	Differential pressure (by nominal size (inches)) kPa {kgf/cm ² }							
				1½	2	2½	3	4	5	6	8
HA2R	140 {1.4}	20 to 98 {0.2 to 1.0}	△	—	—	—	—	—	—	—	—
				3920	3920	3920	3920	2840	—	—	—
				{40.0}	{40.0}	{40.0}	{40.0}	{29.0}	—	—	—
HA3R	140 {1.4}	20 to 98 {0.2 to 1.0}	△	1750	1360	—	—	—	—	—	—
				{17.8}	{13.9}	—	—	—	—	—	—
				1750	1360	—	—	—	—	—	—
HA4R	140 {1.4}	20 to 98 {0.2 to 1.0}	△	—	—	—	—	—	—	—	—
				—	—	—	—	—	—	—	—
				—	—	—	—	—	—	—	—
HA2R	270 {2.8}	80 to 240 {0.8 to 2.4}	✓	9810	8450	6540	4890	2890	—	—	—
				{100.0}	{86.2}	{66.7}	{49.9}	{29.5}	—	—	—
				—	—	—	—	—	—	—	—
HA3R	270 {2.8}	80 to 240 {0.8 to 2.4}	✓	—	3920	3920	3920	3920	3920	2460	—
				—	{40.0}	{40.0}	{40.0}	{40.0}	{40.0}	{25.1}	—
				—	9810	9810	9810	7340	4110	4140	—
HA4R	270 {2.8}	80 to 240 {0.8 to 2.4}	✓	—	—	—	—	3920	3920	3920	3540
				—	—	—	—	{40.0}	{40.0}	{40.0}	{36.1}
				—	—	—	—	9810	9750	9810	7270

Note)1) "□" shows a model with standard actuator.

- 2) ✓ : Positioner is necessary. △ : Can be operated either with or without positioner.
- 3) Take care not to cause the maximum allowable differential pressure to exceed the maximum operating pressure designated by ANSI B16.34-1981 or JIS B2201-1984.
- 4) The upper figures denote the allowable differential pressure. The lower denote allowable differential pressure at full closure.
- 5) Combination of supply pressure 140 kPa and without positioner is able to be selected only for ON-OFF application.

Allowable differential pressure (temperature range: 230 to 360°C)

Table 6 Air-to-close

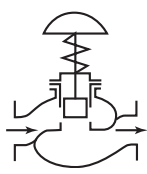

Actuator model No.	Supply pressure kPa{kgf/cm ² }	Spring range kPa{kgf/cm ² }	Positioner	Differential pressure (by nominal size (inches)) kPa {kgf/cm ² }								
				1½	2	2½	3	4	5	6	8	
HA3D	390 {4.0}	80 to 240 {0.8 to 2.4}	✓	3920	3920	3920	3920	3920	3920	3920	3920	—
				{40.0}	{40.0}	{40.0}	{40.0}	{40.0}	{40.0}	{40.0}	—	
HA4D	390 {4.0}	80 to 240 {0.8 to 2.4}	✓	—	—	—	—	3920	3920	3920	3920	—
				{100.0}	{100.0}	{98.1}	{94.5}	{77.4}	{77.4}	{43.7}	—	
HA4D	390 {4.0}	80 to 240 {0.8 to 2.4}	✓	—	—	—	—	810	810	9050	7040	—
				{100.0}	{100.0}	{92.2}	{71.7}	—	—	—	—	

Table 7 Air-to-open

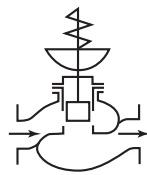

Actuator model No.	Supply pressure kPa{kgf/cm ² }	Spring range kPa{kgf/cm ² }	Positioner	Differential pressure (by nominal size (inches)) kPa {kgf/cm ² }								
				1½	2	2½	3	4	5	6	8	
HA3R	390 {4.0}	80 to 240 {0.8 to 2.4}	✓	3920	3920	3420	3030	3030	3030	1730	—	—
				{40.0}	{40.0}							
HA4R	390 {4.0}	80 to 240 {0.8 to 2.4}	✓	—	—	—	—	3920	3920	3760	2930	—
				{58.7}	{45.5}	{68.0}	{68.0}	{38.3}	{29.8}			

- Note) 1) "□" shows standard combination of valve body and trim materials
 2) ✓ : Positioner is necessary.
 3) Take care not to cause the maximum allowable differential pressure to exceed the maximum operating pressure designated by ANSI B16. 34-1981 or JIS B2201-1984.
 4) The upper figures denote the allowable differential pressure. The lower denote allowable differential pressure at full closure.

DIMENSIONS

Table 8 Face-to-face dimensions

[Unit: mm]

Nominal size (inches)	A							
	JIS 10K FF, RF ANSI 150RF JPI 150RF *	JIS 16KRF	JIS 20K RF JIS 30K RF ANSI 300 RF JPI 300 RF *	JIS 40K RF ANSI 600 RF JPI 600 RF *	JIS 16K Tongue and groove Male and female	JIS 20K Tongue and groove Male and female	JIS 30K Tongue and groove Male and female	JIS 40K Tongue and groove Male and female
1½	222	231	235	251	235	236	248	251
2	254	263	267	286	265	267	276	286
2½	276	288	292	311	290	292	303	311
3	298	313	317	337	310	317	326	337
4	352	364	368	394	360	368	379	394
5	403	425	425	457	—	—	—	—
6	451	465	473	508	475	473	486	508
8	543	560	568	610	570	568	580	610

Nominal size (inches)	A							
	ANSI 150RJ JPI 150RJ	ANSI 300RJ JPI 300RJ	ANSI 600RJ JPI 600RJ	ANSI 300LG JPI 300LG	ANSI 600LG JPI 600LG	ANSI 150 JPI 150SW, BW *	ANSI 300 JPI 300SW, BW *	ANSI 600 JPI 600SW, BW *
1½	235	248	251	244	248	251	251	251
2	267	283	289	276	283	286	286	286
2½	289	308	314	302	308	311	311	311
3	311	333	340	327	333	337	337	337
4	365	384	397	378	391	394	394	396
5	416	441	460	441	460	425	425	457
6	464	489	511	483	505	473	508	508
8	556	584	613	578	606	568	610	610

- Note) *: Face-to-face dimensions conform to following standards.
 - IEC 60534-3-1 : 2001 - IEC 60534-3-3 : 1998 (2½ inches or over)
 - JIS B 2005-3-1 : 2005 - JIS B 2005-3-3 : 2005 (2½ inches or over)

DIMENSIONS**Table 9 External dimensions**

[Unit: mm]

Nominal size (inches)	Actuator model No.	H				B	φB	E
		Plain bonnet	Extension bonnet type 1	Extension bonnet type 2				
				Integral cast type	Welded type			
1 ½	HA2D, R	500	665	780	1020	281	267	70
	HA3D, R	590	765	875	1140	363	350	
2	HA2D, R	500	670	785	1025	281	267	80
	HA3D, R	595	765	875	1140	363	350	
2 ½	HA2D, R	575	745/755	880	1130	281	267	90
	HA3D, R	630	800/810	930	1180	363	350	
3	HA2D, R	580	755/765	900	1135	281	267	100
	HA3D, R	635	810/820	955	1190	363	350	
4	HA2D, R	610	810/820	915	1150	281	267	115
	HA3D, R	660	860/870	1020	1205	363	350	
	HA4D, R	890	1100/1110	1255	1520	520	470	
5	HA3D, R	775	925	1265	1365	363	350	141
	HA4D, R	945	1095	1435	1535	520	470	
6	HA3D, R	785	1020/1045	1250	1385	363	350	170
	HA4D, R	955	1190/1215	1425	1570	520	470	
8	HA4D, R	1090	1350	1580	1710	—	470	220

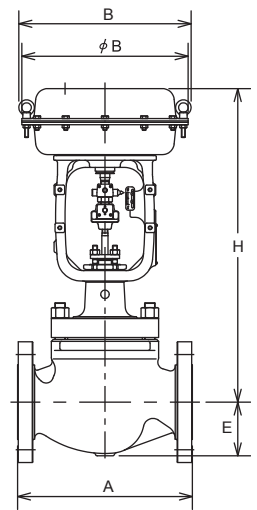
**Figure 4 Face-to-face and other dimensions**

Note) 1) "H" dimension are applicable when a hand wheel is not provided. When top-mounted hand wheel are used, add the hand wheel dimensions designated in specification sheet (No.SS2-8213-0500).

Note) 2) "H" dimensions of Extension bonnet Type 1 are as follows: The left side for JIS 10K and ANSI 150, and the right side for JIS 16K and ANSI 300 or over.

Table 10 Weight

[Unit: kg]

Nominal size (in.)	Actuator model no.	Weight															
		Flange type JIS 10K, ANSI / JPI 150				Flange type JIS 16K, 20K, 30K ANSI / JPI300				Flange type JIS 40K, ANSI / JPI 600				Welded type JIS 10K, 16K, 20K, 30K ANSI / JPI 150, 300, 600			
		Plain bonnet	Extension Type 1 Bellows type	Extension type 2		Plain bonnet	Extension Type 1 Bellows type	Extension type 2		Plain bonnet	Extension Type 1 Bellows type	Extension type 2		Plain bonnet	Extension Type 1 Bellows type	Extension type 2	
				Integral cast type	Welded type			Integral cast type	Welded type			Integral cast type	Welded type			Integral cast type	Welded type
1 ½	HA2R,R	31	34	37	39	36	39	42	44	44	47	50	52	36	39	42	44
	HA3D,R	43	46	49	51	48	51	54	56	56	59	62	64	64	51	54	56
2	HA2D,R	37	40	43	45	42	45	48	50	47	50	53	55	42	45	48	50
	HA3D,R	49	52	55	57	54	57	60	62	59	62	65	67	54	57	60	62
2 ½	HA2R,R	43	47	51	53	48	52	56	58	65	69	73	75	48	52	56	58
	HA3D,R	55	59	63	65	60	64	68	70	77	81	85	87	60	64	68	70
3	HA2R,R	53	59	65	68	63	69	75	78	85	91	97	100	63	69	75	78
	HA3D,R	65	71	77	80	75	81	87	90	97	103	109	112	75	81	87	90
4	HA2D,R	63	73	78	81	78	88	93	96	113	123	128	131	75	85	90	93
	HA3D,R	75	85	90	93	90	100	105	108	125	135	140	143	87	97	102	105
	HA4D,R	106	116	121	124	121	131	136	139	156	166	171	174	118	128	133	136
5	HA3D,R	132	140	154	157	142	150	164	167	187	195	209	212	135	143	157	160
	HA4D,R	168	176	190	193	178	186	200	203	223	231	245	258	168	179	190	193
6	HA3D,R	157	172	179	182	187	202	209	212	237	252	259	262	177	192	199	202
	HA4D,R	188	203	210	213	218	233	240	243	268	283	290	293	208	223	230	233
8	HA4D,R	268	288	298	303	318	338	348	353	438	458	468	473	308	328	338	343

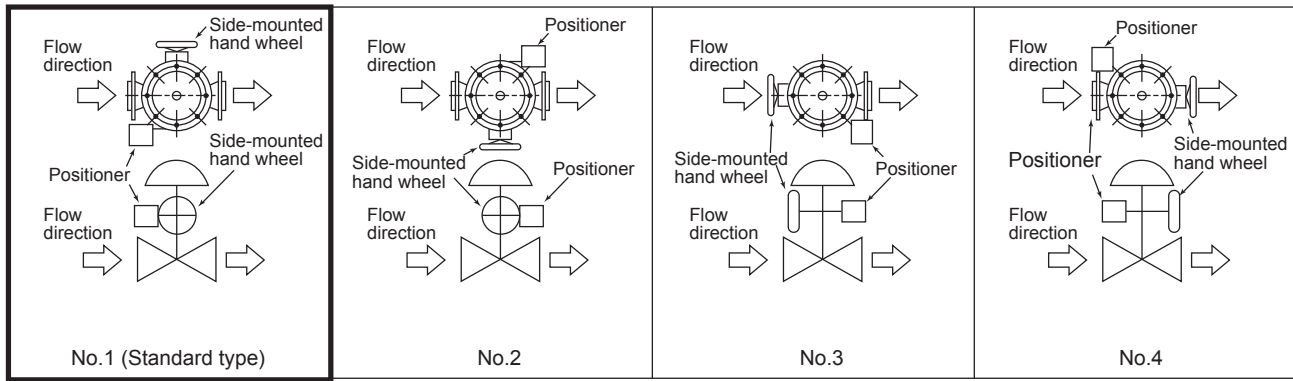

Figure 5 Actuator orientation

Note) Indicate by position number when installation other than the standard type is required.

Ordering information

When ordering, please specify;

- | | |
|---|---|
| <ul style="list-style-type: none"> 1) Model Number: ACN 2) Nominal size × Port size 3) Type and rating of end connections 4) Body and trim material, necessity of hardening 5) Type of bonnet 6) Valve and plug characteristics 7) Type of actuator, air to diaphragm 8) Valve action (direct or reverse) 9) Accessories (positioner, hand wheel, pressure regulator etc.) | <ul style="list-style-type: none"> 10) Special requirement of degreasing, free from copper and etc. 11) Name of flow medium 12) Normal flow and maximum required flow 13) Pressure of flow medium upstream and downstream pressure at maximum and minimum, required flow 14) Temperature and specific gravity of flow medium 15) Viscosity of flow medium, inclusive or exclusive of slurry |
|---|---|

Please read the "Terms and Conditions" from the following URL before ordering or use:

<http://www.azbil.com/products/bi/order.html>

Specifications are subject to change without notice.



Azbil Corporation

Advanced Automation Company

1-12-2 Kawana, Fujisawa
 Kanagawa 251-8522 Japan
 URL: <http://www.azbil.com/>

1st Edition: Issued in Oct. 2001
 3rd Edition: Issued in June 2012

No part of this publication may be reproduced or duplicated without the prior written permission of Azbil Corporation.