

# CV3000 Series

## Small-Port Single Seated Control Valves

### Model HLS

#### **OVERVIEW**

CV3000 Series Small-Port Single Seated Control Valves (model HLS) are designed for heavy duty service. The compact valve body, having an S-shape flow passage that features low pressure loss, allows a large flow capacity, rangeability, and high accuracy flow characteristics.

The valve plugs are available in wide range of Cv values. The flow shutoff performance complies with the IEC or JIS standards. The actuator integrated with simplest mechanisms utilizes a compact yet powerful diaphragm actuator leaded with multiple springs.

The model HLS Control Valve are widely applicable for reliable control of small flows in high or low temperature, high pressure process lines.

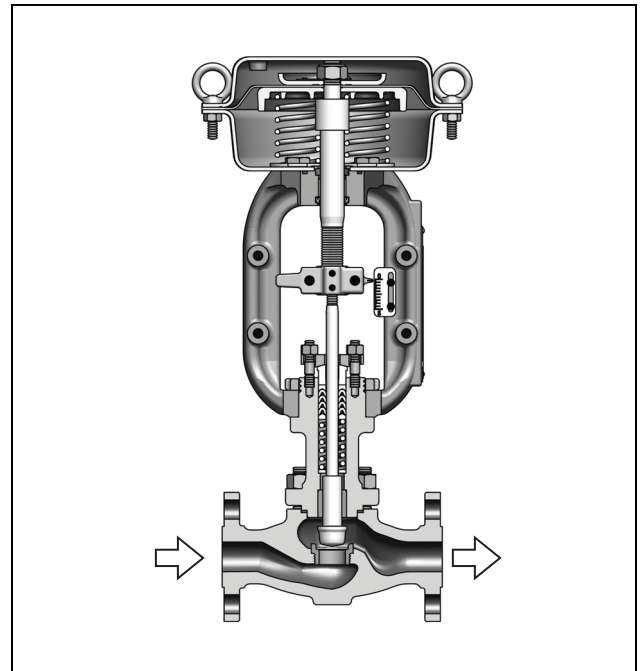

#### **SPECIFICATIONS**

##### **Body**

###### **Type**

Straight-through, cast globe valve

###### **Nominal size**

1/2, 3/4, 1 inch

###### **Pressure rating**

- JIS 10K, 16K, 20K, 30K, 40K
- ANSI Class 125, 150, 300, 600
- JPI Class 125, 150, 300, 600

###### **End connection**

- Flanged end:

Connection type	Pressure rating	Applicable standard
FF	JIS10K	JIS B2210-1984
	ANSI Class 125	ANSI B16.5-1981
	JPI Class 125	JPI-7S-15-1993
RF	JIS10K, 16K, 20K, 30K, 40K	JIS B2210-1984
	ANSI Class 150, 300, 600	ANSI B16.5-1981
	JPI Class150, 300, 600	JPI-7S-15-1993
RJ, LG	ANSI Class 150, 300, 600	ANSI B16.5-1981
	JPI Class 150, 300, 600	JPI-7S-15-1993
Tongue and groove(groove) Male and female(female)	JIS16K, 20K, 30K, 40K	JIS B2202-1984

- Welded end: SW, BW
- Threaded end: Rc

##### **Material**

For body/trim material combinations and operating temperature ranges, refer to Table 1.

##### **Bonnet**

- Plain bonnet (-17 to 230 °C)
- Extension bonnet Type 1 (-45 to -17 °C and 230 to 566 °C)
- Extension bonnet Type 2. Integral-cast type (-100 to -45 °C)  
Welded type (-196 to -100 °C)
- Bellows type (For operating temperature and pressure range, refer to Figure 2.)

*Note) Take care not to exceed the operating temperature ranges specified for respective materials.*

##### **Gland type**

Bolted gland

##### **Packing / Grease**

- Crease not provided: When V shaped PTFE packing or PTFE yarn packing is used.
- Grease provided: When graphite packing is used.

*Note) PTFE: Polytetrafluoroethylene*

**Gasket**

**Type**

Flat type, serrated type

**Material**

Carbon steel (S15C), Stainless steel (SUS316, SUS316L, SUS329J1), copper, aluminum, titanium, ASTM B574 (Hastelloy C-276 equivalent), or Alloy 20

**Note: Sizing**

When the flow rates are small, a laminar flow is formed at the vena contracta of the valve if the fluid viscosity is relatively small or the differential pressure is high. Valve capacity is defined on the assumption that the flow at the vena contracta is turbulent. For this reason, valve capacity at the vena contracta is calculated large unless the Cv value calculation formula is corrected to the logical dimensions, which may produce a valve capacity insufficient for the application. Refer to the Instrumentation Bulletin No. ID2-8000-3800 correcting Cv calculations based on fluid viscosity, and refer to No. PD2-8110-0500 for valves with such micro Cv values as 0.01, 0.04 or 0.1.

**Spring range**

20 to 98 kPa {0.2 to 1.0 kgf/cm<sup>2</sup>} or  
80 to 240 kPa {0.8 to 2.4 kgf/cm<sup>2</sup>}

**Supply pressure**

120 to 390 kPa {1.2 to 4.0 kgf/cm<sup>2</sup>}

*Note) Allowable differential pressure varies depending on spring range and air supply pressure.*

**Air connection**

Rc1/4 or 1/4NPT internal thread

**Ambient temperature**

-30 to 70 °C

**Valve action**

Air-to-close (Direct action actuator is combined.)

Air-to-open (Reverse action actuator is combined.)

**Optional accessories**

Positioner\*, pressure regulator with filter, hand wheel\*, limit switch, solenoid valve, motion transmitter, booster relay, lock-up valve, and others.

*Note) 1) For the optional items, refer to the specification sheets and installation drawings of respective accessories.*

*2) Accessories with the asterisk mark(\*) are selected from among the following types depending on the actuators to be combined.*

Actuator	Positioner		Hand wheel	
	P/P	I/P	Top	Side
PSA1	VPE/HTP	AVP/HEP	THM	SHM
HA2	HTP	AVP/HEP	THM	SHM

**Additional specifications (by special order)**

- Special inspection  
Flow characteristics inspection, material inspection (Material certificate), non-destructive inspection, steam inspection, low-temperature inspection
- With drain plug
- Double gland
- Oil/water free treatment
- Copper free treatment
- York material SCPH2 (Yoke material of PSA1 is SCPH2 as standard)
- Stainless steel (SUS304) atmosphere-exposed nuts and bolts
- Special air piping and joint
- Sand-/dust-preventive measure
- Saline damage countermeasure
- Cold-area use specification
- Tropical-area use specification
- Vacuum service

**Trim**

**Valve plug**

Single seated, Contoured type plug

- Metal seat (for flow characteristics, refer to Figure 1.)  
Equal percentage (%CF), Linear (LCF)
- Soft seat (for flow characteristics, refer to Figure 1.)  
Equal percentage (%TF), Linear (LTF)

Single seated, Quick-opening type plug

- Metal (Stellite) seat (QS)  
When a soft seat is required, use a contoured type soft seat.

*Note) 1) For operating temperature or pressure range of soft seat, refer to Figure 3.*

*2) For rated CV 0.01 to 0.1 cage guide trim*

**Material**

For body/trim material combinations and operating temperature ranges, refer to Table 1.

*Note) For fluid conditions requiring stellite, refer to Figure 4.*

**Actuator**

**Type**

Single acting diaphragm actuator (TypePSA, HA)

**Action**

Direct or reverse action

**Diaphragm**

Cloth embedded ethylene propylene rubber

## Performance

### Rated Cv value

Refer to Table 2.

### Flow characteristics

Refer to Figure 1.

### Inherent rangeability

Refer to Table 2.

- Optional; 75 : 1 for rated Cv 1.0 to 14

### Allowable differential pressure

Refer to Table 3 to Table 8.

### Leakage specifications

- Contoured type plug  
IEC 60534-4:2006 or JIS B 2005-4:2008  
<Metal seat>  
Standard..... Class IV: Leakage less than 0.01% of maximum valve capacity.  
Option..... Leakage less than 0.001% of maximum valve capacity.  
<Soft seat>  
Class VI: Leakage less than 0.00001% of maximum valve capacity.
- Quick opening type plug  
Leakage less than 0.00001% of maximum valve capacity

### Hysteresis error

Without positioner: Within 3% F.S. (Within 5% F.S.)

With positioner: Within 1% F.S.

### Linearity

Without positioner: Within  $\pm 5\%$  F.S.

With positioner: Within  $\pm 1\%$  F.S.

(VPE: Within  $\pm 3\%$  F.S., AVP&HEP: Within  $\pm 2\%$  F.S.)

*Note) 1) When positioner is not provided, operating performance may vary depending on types of packings used.*

*2) Parenthesized figures are applicable to Type PSAI.*

## Dimensions

Refer to Figure 5, Table 13 and Table 14.

## Weight

Refer to Table 15, Table 16 and Table 17.

## Actuator orientation

Refer to Figure 6.

## Finish

Blue (Munsell 10B5/10) or silver, or other specified colors.

Table 1 Body/trim material combinations and operating temperature ranges (°C)

Body material / Trim material		JIS	SCPH2	SCPH21	SCPH61	SCPL1	SCS11	SCS13A	SCS14A	SCS16A	SCS19A
		ASTM	A216WCB	A217WC6	A217C5	A352LCB	-	A351CF8	A351CF8M	A351CF3M	A351CF3
JIS	SUS304		-5 to 300	—	—	-45 to 300	—	-196 to 300	—	—	—
JIS	SUS316		-5 to 300	—	—	-45 to 300	—	-196 to 300	-196 to 300	—	—
JIS	SUS304L		—	—	—	-45 to 300	—	-196 to 300	—	—	-196 to 300
JIS	SUS316L		-5 to 300	-5 to 300	—	-45 to 300	—	-196 to 300	-196 to 300	-196 to 300	-196 to 300
JIS	SUS440C		-5 to 425	-5 to 425	-5 to 425	—	—	—	—	—	—
JIS	SUS329J1		—	—	—	—	-5 to 300	—	-196 to 300	—	—
JIS	SUS304 Stellite		-5 to 425	-5 to 550	-5 to 566	-45 to 350	—	-196 to 550	—	—	—
JIS	SUS304 Stellite face		-5 to 425	-5 to 550	-5 to 566	-45 to 350	—	-196 to 550	—	—	—
JIS	SUS316 Stellite		-5 to 425	-5 to 550	-5 to 566	-45 to 350	—	-196 to 550	-196 to 550	—	—
JIS	SUS316 Stellite face		-5 to 425	-5 to 550	-5 to 566	-45 to 350	—	-196 to 550	-196 to 550	—	—
JIS	SUS304L Stellite		—	—	—	-45 to 350	—	-196 to 550	—	—	-196 to 450
JIS	SUS316L Stellite		—	—	—	-45 to 350	—	-196 to 450	-196 to 450	-196 to 450	-196 to 450
JIS	SUS329J1 Stellite		—	—	—	—	-50 to 550	—	-196 to 550	—	—
JIS	SUS304 Soft seat		-5 to 230	—	—	-45 to 230	—	-80 to 230	—	—	—
JIS	SUS316 Soft seat		-5 to 230	—	—	-45 to 230	—	-80 to 230	-80 to 230	—	—
JIS	SUS316L Soft seat		—	—	—	-45 to 230	—	-80 to 230	-80 to 230	-80 to 230	-80 to 230
JIS	SUS329J1 Soft seat		—	—	—	—	-50 to 230	—	-80 to 230	—	—

Body material / Trim material		JIS	SCPH2	SCS13A	SCS14A	SCS16A	SCS19A	Titanium	Hastelloy C	Alloy 20
		ASTM	A216WCB	A351CF8	A351CF8M	A351CF3M	A351CF3	—	—	—
JIS	Titanium alloy		—	—	—	—	—	-196 to 315	—	—
JIS	Titanium		—	—	—	—	—	-196 to 315	—	—
JIS	Hastelloy C		—	—	—	—	—	—	-196 to 450	—
JIS	Alloy 20		—	—	—	—	—	—	—	-196 to 300
JIS	Monel		-5 to 300	-196 to 300	-196 to 300	-196 to 300	-196 to 300	—	—	—

Note) “” shows standard combination of value body and trim materials.

Table 2 Cv value and travel

Plug type/ characteristics / Rated travel (mm) / Rated Cv value		0.01	0.04	0.1	0.16	0.25	0.4	0.63	1.0	1.6	2.5	4.0	6.3	10	14
Contoured type	Metal seat	Equal percentage (%CF)				✓	✓	✓	✓	✓	✓	✓	✓	✓	✓
		Linear (LCF)	✓	✓	✓	✓	✓	✓	✓	✓	✓	✓	✓	✓	✓
	Soft seat	Equal percentage (%TF)				✓	✓	✓	✓	✓	✓	✓	✓	✓	✓
		Linear (LTF)				✓	✓	✓	✓	✓	✓	✓	✓	✓	✓
Quick-opening type	Metal (Stellite) seat (QS)	6.0												✓	✓
Inherent rangeability		20:1	25:1	20:1	30:1	50:1									
Nominal size (inch)	1/2 inch	←—————→													
	3/4 inch	←—————→													
	1 inch	←—————→													

Note) “✓” denotes production ranges.

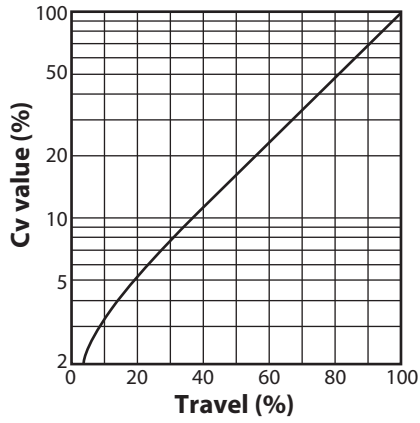

a. Equal percentage characteristics (%CF Metal seat)

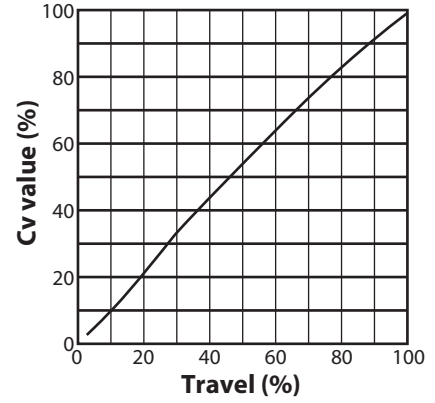

b. Linear characteristics (LCF Metal seat)

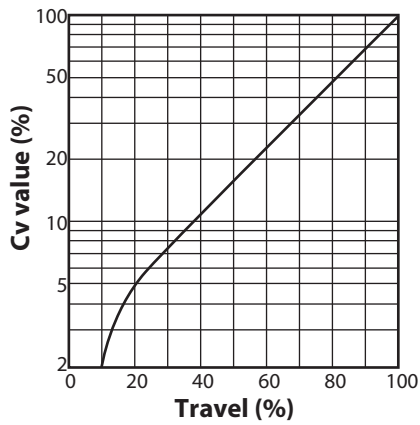

c. Equal percentage characteristics (%TF Soft seat)

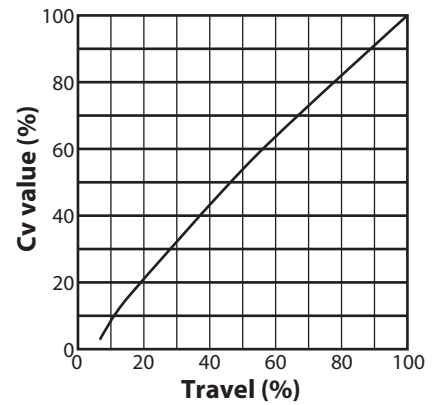

d. Linear characteristics (LTF Soft seat)

**Figure 1 Flow characteristics: Contoured type (Cv value: 0.4 to 1.4)**

*Note) The above graphs indicate typical flow characteristics.*

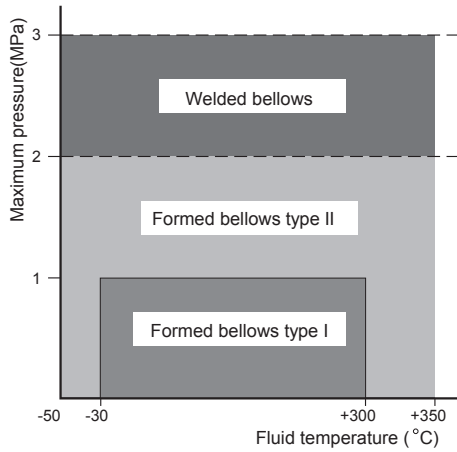

**Figure 2 Bellows Type by Temperature and Pressure Ranges**

Note) Bellows type are classified into Formed bellows type I, II and welded bellows by temperature and pressure ranges.  
Please refer to No. SS2-BSL100-0100 about detail of bellows specification.

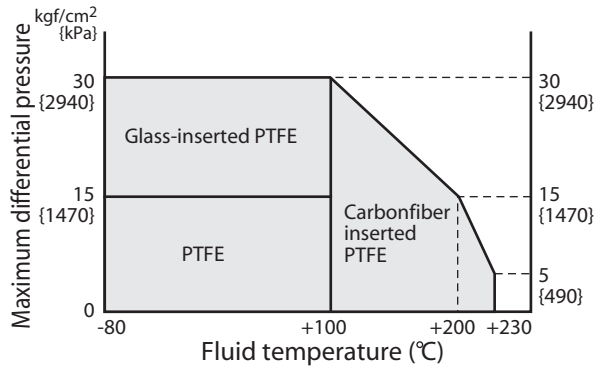

**Figure 3 Temperature and maximum differential pressure range for soft-seat**

Note) If there is any possibility to cause erosion due to saturated steam or superheated-water, use the metal seat.

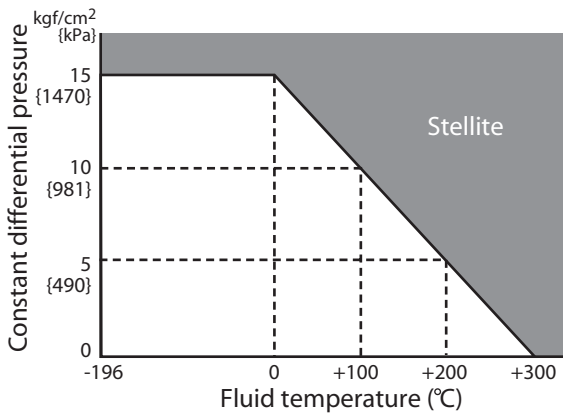

**Figure 4 Temperature / normal differential pressure ranges requiring Stellite**

- Note) 1) When cavitation / flashing service, oil prohibitive service, or retention of valve-close performance is required, use of Stellite is recommended regardless of temperature or differential pressure.
- 2) SUS440C hardened Stainless steel is recommended for valves for cavitation / flashing service of water or for superheated service of water of higher than 100°C.
- 3) When rated Cv value is 0.16 or lower, Stellite faced valve plugs or 440C hardened Stainless steel valve plugs are standard.

**Allowable differential pressure**

**Contoured-type metal seat (%CF, LCF) : PTFE packing**

Table 3 Air-to-close

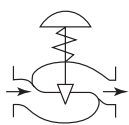

Actuator Model No.	Supply Pressure kPa {kgf/cm <sup>2</sup> }	Spring range kPa {kgf/cm <sup>2</sup> }	Positioner	Differential pressure {by Cv value} kPa {kgf/cm <sup>2</sup> }											
				Below 0.1	0.16 to 0.25	0.4	0.63	1.0	1.6	2.5	4.0	6.3	10	14	
PSA1D	140 {1.4}	20 to 98 {0.2 to 1.0}	△	—	3920* {40.0}	3040 {31.0}	3040 {31.0}	1570 {16.0}	1570 {16.0}	981 {10.0}	981 {10.0}	550 {5.6}	410 {4.2}	250 {2.6}	
				—	5490 {56.0}										
	160 {1.6}	20 to 98 {0.2 to 1.0}	✓	—	3920* {40.0}	3920* {40.0}	3920* {40.0}	3920* {40.0}	3920* {40.0}	3920* {40.0}	3920* {40.0}	3920* {40.0}	2740 {28.0}	2060 {21.0}	1270 {13.0}
				—	9810 {100}	9810 {100}	9810 {100}	8240 {84.0}	8240 {84.0}	5100 {52.0}	5100 {52.0}				
	390 {4.0}	80 to 240 {0.8 to 2.4}	✓	3920* {40.0}	—	—	—	—	—	—	3920* {40.0}	3920* {40.0}	3920* {40.0}	3920* {40.0}	3820 {39.0}
				9810 {100}	—	—	—	—	—	9810 {100}	9810 {100}	8240 {84.0}	6180 {63.0}		
HA2D	140 {1.4}	20 to 98 {0.2 to 1.0}	△	—	3920* {40.0}	3920* {40.0}	3920* {40.0}	3200 {32.6}	3200 {32.6}	1960 {20.0}	1960 {20.0}	1070 {10.9}	800 {8.2}	490 {5.0}	
				—	9810 {100}	6080 {62.0}	6080 {62.0}								
	160 {1.6}	20 to 98 {0.2 to 1.0}	✓	—	—	3920* {40.0}	3920* {40.0}	3920* {40.0}	3920* {40.0}	3920* {40.0}	3920* {40.0}	3920* {40.0}	3920* {40.0}	3920* {40.0}	2470 {25.2}
				—	—	9810 {100}	9810 {100}	9810 {100}	9810 {100}	9810 {100}	9810 {100}	9810 {100}	5300 {54.0}		
	390 {4.0}	80 to 240 {0.8 to 2.4}	✓	3920* {40.0}	—	—	—	—	—	—	—	—	3920* {40.0}	3920* {40.0}	3920* {40.0}
				9810 {100}	—	—	—	—	—	—	—	9810 {100}	9810 {100}	7350 {75.0}	

Table 4 Air-to-open

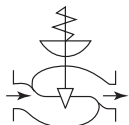

Actuator Model No.	Supply pressure kPa {kgf/cm <sup>2</sup> }	Spring range kPa {kgf/cm <sup>2</sup> }	Positioner	Differential pressure {by Cv value} kPa {kgf/cm <sup>2</sup> }											
				Below 0.1	0.16 to 0.25	0.4	0.63	1.0	1.6	2.5	4.0	6.3	10	14	
PSA1R	140 {1.4}	20 to 98 {0.2 to 1.0}	△	—	3920* {40.0}	3040 {31.0}	3040 {31.0}	1570 {16.0}	1570 {16.0}	981 {10.0}	981 {10.0}	550 {5.6}	410 {4.2}	250 {2.6}	
				—	5490 {56.0}										
	270 {2.8}	80 to 240 {0.8 to 2.4}	✓	3920* {40.0}	3920* {40.0}	3920* {40.0}	3920* {40.0}	3920* {40.0}	3920* {40.0}	3920* {40.0}	3920* {40.0}	3820 {39.0}	2840 {29.0}	1760 {18.0}	
				9810 {100}	9810 {100}	9810 {100}	9810 {100}	9810 {100}	7060 {72.0}	7060 {72.0}					
HA2R	140 {1.4}	20 to 98 {0.2 to 1.0}	△	—	3920* {40.0}	3920* {40.0}	3920* {40.0}	3200 {32.6}	3200 {32.6}	1960 {20.0}	1960 {20.0}	1070 {10.9}	800 {8.2}	490 {5.0}	
				—	9810 {100}	6080 {62.0}	6080 {62.0}								
	270 {2.8}	80 to 240 {0.8 to 2.4}	✓	3920* {40.0}	—	3920* {40.0}	3920* {40.0}	3920* {40.0}	3920* {40.0}	3920* {40.0}	3920* {40.0}	3920* {40.0}	3920* {40.0}	3920 {40.0}	3430 {35.0}
				9810 {100}	—	9810 {100}	9810 {100}	9810 {100}	9810 {100}	9810 {100}	9810 {100}	7450 {75.9}	5490 {56.0}		

Note) 1) ✓ : Positioner is necessary, △ : Can be operated either with or without positioner.

2) Take care not to cause the maximum allowable differential pressure to exceed the maximum operating pressure designated by ANSI B 16. 34-1981 or JIS B2201-1984.

3) The upper figures denote the operating allowable differential pressure. The lower denote allowable differential pressure at full closure.

4) When liquid service the operating allowable differential pressure with an asterisk(\*) should be read as 2940 kPa {30 kgf/cm<sup>2</sup>}. When operating differential pressure of liquid exceeds 2940 kPa {30 kgf/cm<sup>2</sup>}, use model HLC. (Refer to the Specification sheet No.SS2-8113-0210.)

**Allowable differential pressure**

**Contoured type soft seat (%TF, LTF) : PTFE packing**

Table 5 Air-to-close

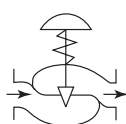

Actuator Model No.	Supply Pressure kPa {kgf/cm <sup>2</sup> }	Spring range kPa {kgf/cm <sup>2</sup> }	Positioner	Differential pressure {by Cv value} kPa {kgf/cm <sup>2</sup> }									
				Below 0.25	0.4	0.63	1.0	1.6	2.5	4.0	6.3	10	14
PSA1D	140 {1.4}	20 to 98 {0.2 to 1.0}	△	710 {7.2}	710 {7.2}	710 {7.2}	710 {7.2}	710 {7.2}	710 {7.2}	710 {7.2}	390 {4.0}	280 {2.9}	180 {1.8}
	160 {1.6}	20 to 98 {0.2 to 1.0}	✓	2940 {30.0}	2940 {30.0}	2940 {30.0}	2940 {30.0}	2940 {30.0}	2940 {30.0}	2940 {30.0}	1860 {19.0}	1370 {14.0}	890 {9.1}
	390 {4.0}	80 to 240 {0.8 to 2.4}	✓	—	—	—	—	—	—	—	—	2940 {30.0}	2940 {30.0}
HA2D	140 {1.4}	20 to 98 {0.2 to 1.0}	△	1960 {20.0}	1960 {20.0}	1960 {20.0}	1960 {20.0}	1960 {20.0}	1370 {14.0}	1370 {14.0}	740 {7.6}	560 {5.7}	340 {3.5}
	160 {1.6}	20 to 98 {0.2 to 1.0}	✓	—	2940 {30.0}	2940 {30.0}	2940 {30.0}	2940 {30.0}	2940 {30.0}	2940 {30.0}	2940 {30.0}	2740 {28.0}	1720 {17.6}
	390 {4.0}	80 to 240 {0.8 to 2.4}	✓	—	—	—	—	—	—	—	—	2940 {30.0}	2940 {30.0}

Table 6 Air-to-open

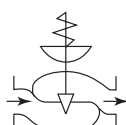

Actuator Model No.	Supply Pressure kPa {kgf/cm <sup>2</sup> }	Spring range kPa {kgf/cm <sup>2</sup> }	Positioner	Differential pressure {by Cv value} kPa {kgf/cm <sup>2</sup> }									
				Below 0.25	0.4	0.63	1.0	1.6	2.5	4.0	6.3	10	14
PSA1R	140 {1.4}	20 to 98 {0.2 to 1.0}	△	710 {7.2}	710 {7.2}	710 {7.2}	710 {7.2}	710 {7.2}	710 {7.2}	710 {7.2}	390 {4.0}	280 {2.9}	180 {1.8}
	270 {2.8}	80 to 240 {0.8 to 2.4}	✓	2940 {30.0}	2940 {30.0}	2940 {30.0}	2940 {30.0}	2940 {30.0}	2940 {30.0}	2940 {30.0}	2650 {27.0}	1960 {20.0}	1180 {12.0}
HA2R	140 {1.4}	20 to 98 {0.2 to 1.0}	△	1960 {20.0}	1960 {20.0}	1960 {20.0}	1960 {20.0}	1960 {20.0}	1370 {14.0}	1370 {14.0}	740 {7.6}	560 {5.7}	340 {3.5}
	270 {2.8}	80 to 240 {0.8 to 2.4}	✓	—	2940 {30.0}	2940 {30.0}	2940 {30.0}	2940 {30.0}	2940 {30.0}	2940 {30.0}	2940 {30.0}	2940 {30.0}	2350 {24.0}

Note) 1) ✓ : Positioner is necessary, △ : Can be operated either with or without positioner.  
 2) Take care not to cause the maximum allowable differential pressure to exceed the maximum operating pressure designated by ANSI B 16. 34-1981 or JIS B2201-1984.

**Quick-opening type metal (Stellite) seat (QS) : PTFE packing**

Table 7 Air-to-close

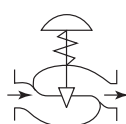

Action Model No.	Supply pressure kPa {kgf/cm <sup>2</sup> }	Spring range kPa {kgf/cm <sup>2</sup> }	Differential pressure kPa {kgf/cm <sup>2</sup> }	
			Cv=10	Cv=14
PSA1D	140 {1.4}	20 {0.2}	720 {7.3}	490 {5.0}
	290 {3.0}	20 {0.2}	1960 {20.0}	1760 {18.0}
HA2D	140 {1.4}	20 to 52 {0.2 to 0.53}	1430 {14.6}	1270 {13.0}
	290 {3.0}	20 to 52 {0.2 to 0.53}	3920 {40.0}	3630 {37.0}

Table 8 Air-to-open

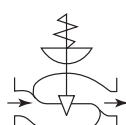

Action Model No.	Supply pressure kPa {kgf/cm <sup>2</sup> }	Initial spring compression kPa {kgf/cm <sup>2</sup> }	Differential pressure kPa {kgf/cm <sup>2</sup> }	
			Cv=10	Cv=14
PSA1R	140 {1.4}	40 {0.4}	330 {3.4}	290 {3.0}
	270 {2.8}	80 {0.8}	670 {6.8}	590 {6.0}
HA2R	140 {1.4}	40 {0.4}	660 {6.7}	590 {6.0}
	270 {2.8}	80 {0.8}	1320 {13.5}	1190 {12.1}

Note) Take care not to cause the maximum allowable differential pressure to exceed the maximum operating pressure designated by ANSI B16. 34-1981 or JIS B2201-1984.

## Contoured type metal seat (%CF, LCF) : Graphite packing "P6610CH+P6528"(+230 to +500 °C)

Table 9 Air-to-close

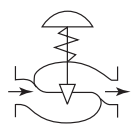

Actuator Model No.	Supply Pressure kPa{kgf/cm <sup>2</sup> }	Spring range kPa{kgf/cm <sup>2</sup> }	Positioner	Differential pressure {by Cv value} kPa {kgf/cm <sup>2</sup> }											
				Below 0.1	0.16 to 0.25	0.4	0.63	1.0	1.6	2.5	4.0	6.3	10	14	
HA1D	390 {4.0}	80 to 240 {0.8 to 2.4}	✓	3920* {40.0}	3920* {40.0}	3920* {40.0}	3920* {40.0}	3920* {40.0}	3920* {40.0}	3920* {40.0}	3920* {40.0}	3920* {40.0}	3920* {40.0}	3920* {40.0}	3920* {40.0}
				9810 {100}	9810 {100}	9810 {100}	9810 {100}	9810 {100}	9810 {100}	9810 {100}	9810 {100}	9810 {100}	9810 {100}	9810 {100}	9810 {100}

Table 10 Air-to-open

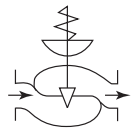

Actuator Model No.	Supply Pressure kPa{kgf/cm <sup>2</sup> }	Spring range kPa{kgf/cm <sup>2</sup> }	Positioner	Differential pressure {by Cv value} kPa {kgf/cm <sup>2</sup> }											
				Below 0.1	0.16 to 0.25	0.4	0.63	1.0	1.6	2.5	4.0	6.3	10	14	
HA1R	270 {2.8}	80 to 240 {0.8 to 2.4}	✓	3920* {40.0}	3920* {40.0}	3920* {40.0}	3920* {40.0}	3920* {40.0}	3920* {40.0}	3920* {40.0}	3920* {40.0}	3920* {40.0}	3920* {40.0}	3920* {40.0}	2710 {27.6}
				9810 {100}	9810 {100}	9810 {100}	9810 {100}	9810 {100}	9810 {100}	9810 {100}	9810 {100}	9810 {100}	5900 {60.1}	4400 {44.8}	

Note) 1) ✓ : Positioner is necessary.

2) Take care not to cause the maximum allowable differential pressure to exceed the maximum operating pressure designated by JIS B 2201-1984 or ANSI B 16.34-1981.

3) The upper figures denote the operating allowable differential pressure. The lower denote allowable differential pressure at full closure.

4) When liquid service, the operating allowable differential pressure with an asterisk(\*) should be read as 2940 kPa {30 kgf/cm<sup>2</sup>}. When operating differential pressure of liquid exceeds 2940 kPa {30 kgf/cm<sup>2</sup>}, use model HLC. (Refer to the Specification sheet No.SS-8113-0210)

## Contoured type metal seat (%CF, LCF) : Graphite packing "P6610CH+M8590"(+500 to +560 °C)

Table 11 Air-to-close

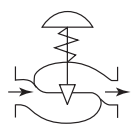

Actuator Model No.	Supply Pressure kPa{kgf/cm <sup>2</sup> }	Spring range kPa{kgf/cm <sup>2</sup> }	Positioner	Differential pressure {by Cv value} kPa {kgf/cm <sup>2</sup> }											
				Below 0.1	0.16 to 0.25	0.4	0.63	1.0	1.6	2.5	4.0	6.3	10	14	
HA2D	390 {4.0}	80 to 240 {0.8 to 2.4}	✓	3920* {40.0}	3920* {40.0}	3920* {40.0}	3920* {40.0}	3920* {40.0}	3920* {40.0}	3920* {40.0}	3920* {40.0}	3920* {40.0}	3920* {40.0}	3920* {40.0}	3920* {40.0}
				9810 {100}	9810 {100}	9810 {100}	9810 {100}	9810 {100}	9810 {100}	9810 {100}	9810 {100}	9810 {100}	9810 {100}	9810 {100}	9450 {96.3}

Table 12 Air-to-open

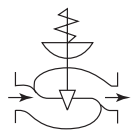

Actuator Model No.	Supply Pressure kPa{kgf/cm <sup>2</sup> }	Spring range kPa{kgf/cm <sup>2</sup> }	Positioner	Differential pressure {by Cv value} kPa {kgf/cm <sup>2</sup> }												
				Below 0.1	0.16 to 0.25	0.4	0.63	1.0	1.6	2.5	4.0	6.3	10	14		
HA2R	270 {2.8}	80 to 240 {0.8 to 2.4}	✓	3920* {40.0}	3920* {40.0}	3920* {40.0}	3920* {40.0}	3920* {40.0}	3920* {40.0}	3920* {40.0}	3920* {40.0}	3920* {40.0}	3920* {40.0}	3920* {40.0}	3750 {38.2}	2310 {23.5}
				9810 {100}	9810 {100}	9810 {100}	9810 {100}	9810 {100}	9810 {100}	9810 {100}	9810 {100}	9260 {94.4}	5020 {51.1}			

Note) 1) ✓ : Positioner is necessary.

2) Take care not to cause the maximum allowable differential pressure to exceed the maximum operating pressure designated by JIS B 2201-1984 or ANSI B 16.34-1981.

3) The upper figures denote the operating allowable differential pressure. The lower denote allowable differential pressure at full closure.

4) When liquid service, the operating allowable differential pressure with an asterisk(\*) should be read as 2940 kPa {30 kgf/cm<sup>2</sup>}. When operating differential pressure of liquid exceeds 2940 kPa {30 kgf/cm<sup>2</sup>}, use model HLC. (Refer to the Specification sheet No.SS-8113-0210)

**DIMENSIONS**

Table 13 Face-to-face dimensions

[Unit: mm]

Nominal size (inch)		1/2	3/4	1
A	JIS 10K FF, RF      ANSI 150 RF *	184	184	184
	ANSI 125 FF      JPI 150 RF			
	JPI 125 FF			
	JIS 16K RF	190	190	193
	JIS 20K RF      ANSI 300 RF *	194	194	197
	JIS 30K RF      JPI 300 RF			
	JIS 40K RF      JPI 600 RF SW, BW *	206	206	210
	ANSI 600 RF			
	ANSI 150 RJ      JPI 150 RJ			197
	ANSI 300 RJ      JPI 300 RJ	206	206	210
	ANSI 600 RJ      JPI 600 RJ	206	206	210
	JIS 20K      Tongue and groove male and female	198	198	198
	JIS 30K      Tongue and groove male and female	208	208	212
	ANSI 300 LG      JPI 300	203	203	206
Threaded end connection type	125	125	125	

Note) \*: Face-to-face dimensions conform to following standards.  
 -IEC 60534-3-1:2001  
 -JIS B 2005-3-1:2005

Table 14 External dimensions

[Unit: mm]

Actuator model no.	H				Bellows - type bonnet	φ B	B	E
	Plain bonnet	Extension bonnet Type 1	Extension bonnet Type 2					
			Integral cast type	Welded type				
PSA1D, R	416	566	726	941	566	218	230	40
HA2D, R	450	600	760	975	600	267	281	40

Note) "H" dimensions are applicable when a hand wheel is not provided. When a top-mounted hand wheel actuator is used, add the dimensions of hand wheel specified on Specification Sheets (No.SS2-8213-0500).

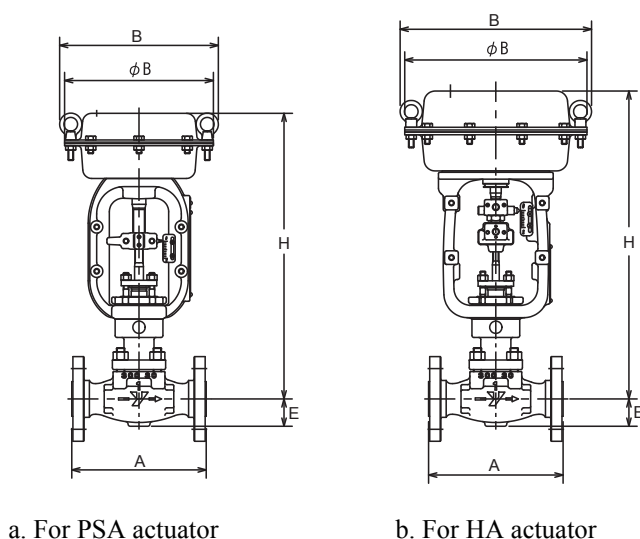

Figure 5 Face-to-face and external dimensions

**Weight****Table 15 Screwed end connection type**

[Unit: kg]

Nominal size (inches)	Actuator model	Weight				
		Plain bonnet	Extension bonnet Type 1	Extension bonnet Type 2		Bellows-type bonnet
				Integral cast type	Welded type	
1/2	PSA1D, R	13	15	18	23	16
3/4	PSA2D, R	20	22	25	30	23
1						

**Table 16 Flanged end connection type**

[Unit: kg]

Nominal size (inch)	Actuator model No.	Weight									
		JIS 10K, ANSI 125, 150, JPI 125, 150					JIS 16K, 20K, 30K, 40K, ANSI 300, 600, JPI 300, 600				
		Plain bonnet	Extension bonnet type	Extension bonnet Type 2		Bellows- type bonnet	Plain bonnet	Extension bonnet Type 1	Extension bonnet Type 2		Bellows- type bonnet
				Integral- cast type	Welded type				Integral- cast type	Welded type	
1/2	PSA1D,R	15	17	20	25	18	16	18	21	26	19
	HA2D,R	22	24	27	32	25	23	25	28	33	26
3/4	PSA1D,R	16	18	21	26	19	17	19	22	27	20
	HA2D,R	23	25	28	33	26	24	26	29	34	27
1	PSA1D,R	16	18	21	26	19	17	19	22	27	20
	HA2D,R	23	25	28	33	26	24	26	29	34	27

**Table 17 Welded type**

[Unit: kg]

Nominal size (inch)	Actuator model No.	Weight				
		Plain bonnet	Extension bonnet Type 1	Extension bonnet Type 2		Bellows-type bonnet
				Integral cast type	Welded type	
1/2, 3/4, 1 (SW)	PSA1D, R	14	16	19	24	19
	HA2D, R	21	23	26	31	26

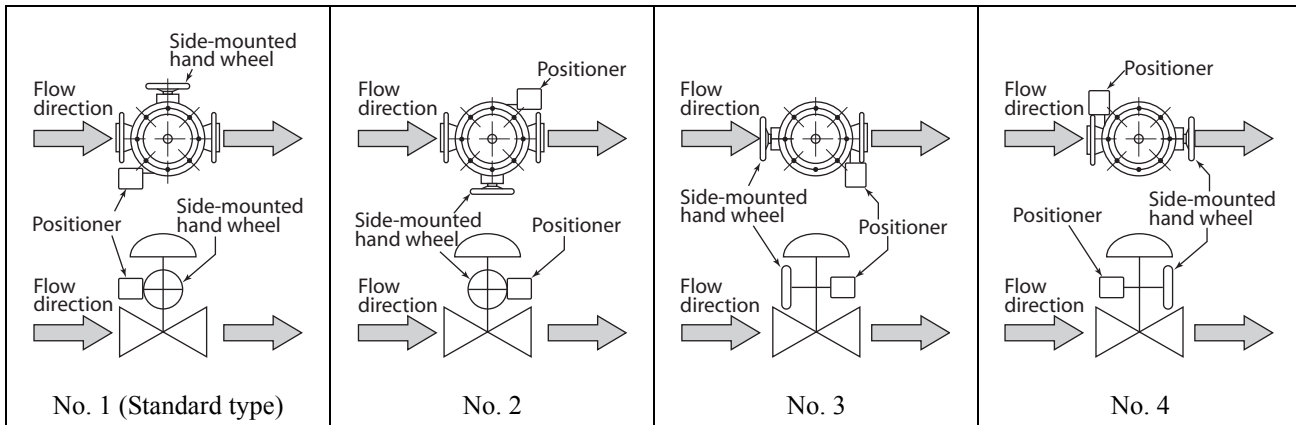

**Figure 6 Actuator orientation**

*Note) Indicate by position number when installation other than the standard type is required.*

## Ordering information

*When ordering, please specify;*

- |  |   |
|--|---|
| 1) Model Number: HLS   | 9) Accessories (pressure regulator and etc.)  |
| 2) Nominal size × Cv required                                      | 10) Special requirement of degreasing, copper free and etc.   |
| 3) Type and rating of end connections                              | 11) Name of flow medium   |
| 4) Body and trim material, necessity of hardening                  | 12) Normal flow and maximum required flow   |
| 5) Type of bonnet  | 13) Pressure of flow medium, upstream and downstream pressure at maximum and minimum, required flow |
| 6) Valve and plug characteristics                                  | 14) Temperature and specific gravity of flow medium   |
| 7) Type of actuator, necessity of hand wheel, and air to diaphragm | 15) Viscosity of flow medium, inclusive or exclusive of slurry                                      |
| 8) Valve action (direct or reverse)                                |   |

Please read the "Terms and Conditions" from the following URL before ordering or use:

<http://www.azbil.com/products/bi/order.html>

*Specifications are subject to change without notice.*

**azbil**

**Azbil Corporation**

Advanced Automation Company

1-12-2 Kawana, Fujisawa

Kanagawa 251-8522 Japan

URL: <http://www.azbil.com/>

1st Edition: Issued in Mar. 2001  
14th Edition: Issued in June 2012

*No part of this publication may be reproduced or duplicated without the prior written permission of Azbil Corporation.*