

Yamatake <b>YAMATAKE</b> Corporation	<b>INSPECTION PROCEDURE</b>	<b>SF2-8000-0001</b>	
	Control valve (general)	ISSUED	May.1.'98
		PAGE	1 OF 9

## Contents

<b>1.Scope</b> .....	<b>2</b>
<b>2.Outline</b> .....	<b>2</b>
<b>3.General Structure and Specification Check</b> .....	<b>2</b>
3.1 Structure and Specifications .....	2
3.2 Appearance .....	2
3.3 Dimensions .....	2
<b>4.Pressure and Leak Test</b> .....	<b>3</b>
4.1 Actuator .....	3
4.2 Valve Body.....	4
<b>5.Seat Leakage Test</b> .....	<b>6</b>
5.1 Double-seated Valves.....	6
5.2 Single-seated Valves , Three-way Valves .....	6
<b>6.Valve Action Test</b> .....	<b>7</b>
6.1 Travel .....	7
6.2 Opening, Closing and Rated Travel Point .....	7
6.3 Linearity. ....	8
6.4 Hysteresis Error .....	8

Yamatake  Corporation	<b>INSPECTION PROCEDURE</b>	SF2-8000-0001	
	Control valve (general)	ISSUED	May.1.'98
		PAGE	2 OF 9

## 1.Scope

This test procedure shall be applied to the customer-witnessed test for the following completed pneumatic actuating automatic control valves.

Model numbers:

HLS, HLC, HTS, HSC, HCU, HPS, HCB, HCP, HPC, HCN, HAV, HMT, HDT, VST, VDC, VDN, VDP, VAA, VAC, VSL, VTM, VAV, EGVT, VTD, HAF, ACP, ACN, AMT.

## 2.Outline

This inspection shall be carried out for the following items:

- (1) Visual inspection of the valve structure and specifications.
- (2) Measuring major dimensions of the valve and checking for its permissible differences.
- (3) Pressure and leak test for confirming no-leakage from the valve body, actuator and its air piping.
- (4) Valve seat leakage test for confirming the shut-off performance.
- (5) Action test for confirming the accuracy of valve opening degrees.

## 3.General Structure and Specification Check

### 3.1 Structure and Specifications

The structure, specification and nameplate of the valve shall be confirmed as per those stated in the approved drawings.

### 3.2 Appearance

The appearance check shall be carried out by visual inspection.

Harmful casting nests, casting burrs, adhering sand fusion scale and crack shall not be found inside and outside of the casting products.

Tucking and joggling cracks shall not be found on the forged products.

Harmful cracks and irregularities in finishing levels shall not be found on the machined surfaces.

Accessories shall be securely mounted, bolts and nuts shall be firmly tightened, flow direction mark shall be provided with an arrow.

### 3.3 Dimensions

The dimensions of major part shall be confirmed as per those stated in the approved drawings, and tolerance shall be as shown in Table 1.

Tolerance in flange dimensions shall be as shown in Attachment 1.

Yamatake <b>YAMATAKE</b> Corporation	<b>INSPECTION PROCEDURE</b>	SF2-8000-0001	
	Control valve (general)	ISSUED	May.1.'98
		PAGE	3 OF 9

Table 1. Tolerance of major dimensions

Dimensional item	Tolerance
Face-to-face(A) (Note)	Nominal valve size: 10 inches (250mm) and under $\pm 1.5$ mm 12 inches (300 mm) and over $\pm 3.0$ mm
Height (H)	$\pm 5\%$
Actuator outer diameter ( B )	$\pm 5\%$
From body center to bottom (E)	$\pm 10\%$

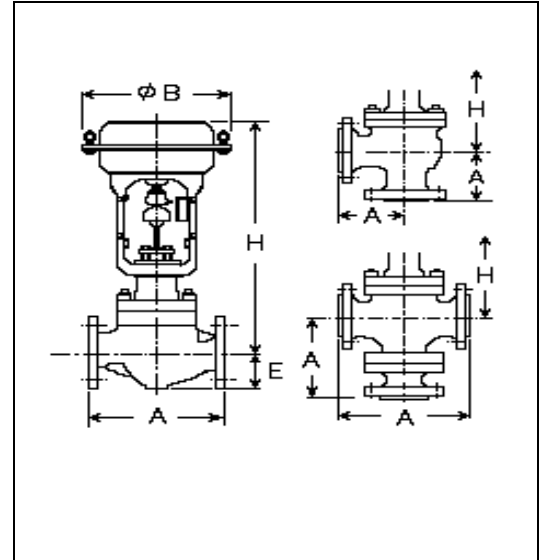

Note. In case of Three-way valves, Tolerance of A shall be  $\pm 2.0$  mm for 6 inches and under,  $\pm 3.0$  mm for 8 inches and over.

#### 4. Pressure and Leak Test

Pressure and leak test of the valve shall be carried out for pneumatic actuator and valve body using following procedure.

##### 4.1 Actuator

In the witnessed test after positioner, solenoid valve and others (if any) are mounted and piped on the actuator, no leakage on the actuator and its piping shall be confirmed, by applying the supply air pressure stated in the approved drawings.

Pressure test of this actuator, before completion, had been carried out and passed in accordance with the test conditions of Table 2.

Table 2. Pressure and leak test conditions for an actuator

Model	Test fluid	Test pressure	Duration time
VA (Diaphragm type)	Air	350 kPa (3.5 kgf/cm <sup>2</sup> )	3 minutes
HA (Diaphragm type)		490 kPa (5.0 kgf/cm <sup>2</sup> )	
VP ,PSA6R,SLOP (Piston cylinder type)		690 kPa (7.0 kgf/cm <sup>2</sup> )	

Yamatake	<b>INSPECTION PROCEDURE</b>	<b>SF2-8000-0001</b>	
	Control valve (general)	ISSUED	May.1.'98
		PAGE	4 OF 9

#### 4.2 Valve Body

This test is carried out for the joint section of gaskets, drain plugs, gland packing and body outer surfaces.

Leakage, penetration at each part and generation of bubbles shall not be found on the test conditions stated in Table 3.

Pressure test of the body shell test, before completion, had been carried out and passed in accordance with ANSI B 16.34 or JIS B 2238,2239.

Yamatake <b>YAMATAKE</b> Corporation	<b>INSPECTION PROCEDURE</b>	<b>SF2-8000-0001</b>	
	Control valve (general)	ISSUED	May.1.'98
		PAGE	5 OF 9

Table 3. Pressure and leak test conditions for a valve body

Valve specification	Test fluid	Test pressure	Duration time
General valve (including PTFE seated valve)	Water	Use higher pressure (1) or (2) as below (1) Rated pressure. [ANSI.API.JPI] Class 150 : 2.1MPa (21kgf/cm <sup>2</sup> ) 300 : 4.2MPa (42kgf/cm <sup>2</sup> ) 600 : 8.3MPa (84kgf/cm <sup>2</sup> ) 900 : 12.4MPa (126kgf/cm <sup>2</sup> ) 1500 : 21MPa (210kgf/cm <sup>2</sup> ) 2500 : 35MPa (350kgf/cm <sup>2</sup> ) [JIS] Cast steel valves : Twice nominal pressure Cast iron valves : 1.5 times designed pressure (2) Operating pressure 1.5 times the maximum operating pressure	10 minutes
Water-prohibitive valve. Oil-prohibitive valve. Low temperature valve. Chlorine valve. Bellows sealed valve. Stellite On-off valve.	Air or (N <sub>2</sub> Gas)	1.25 times the maximum operating pressure. However, the minimum pressure shall be 690 kPa(7.0kgf/cm <sup>2</sup> )	5 minutes
High-pressure Gas safe law approved valve.	Water and Air or (N <sub>2</sub> Gas)	Water pressure : 1.5 times designed pressure Air-tight : 1.0 time designed pressure	10 minutes
	Remarks : For such as oil or water prohibitive valves which can not undergo water-pressure test, 1.5 times the designed pressure is used for air-tight test.		

<b>Yamatate</b>  <b>Corporation</b>	<b>INSPECTION PROCEDURE</b>	<b>SF2-8000-0001</b>	
	Control valve (general)	ISSUED	May.1.'98
		PAGE	6 OF 9

## 5. Seat Leakage Test

This test shall check valve seat leakage when the valve is completely closed. The test fluid shall apply to the inlet side of the valve.

The air pressure to the actuator in this test shall be the supply pressure for direct-action valves and zero kPa (kgf/cm<sup>2</sup>) for reverse-action valves.

Classifications of shut-off performance shall conform to IEC standard.

### 5.1 Double-seated Valves

Model numbers: HCB, HPC, HCP, HCN, VDC, VDN, VAC, VDP.

The shut-off performance of these valves shall be applied following permissible maximum values.

**Metal-seat:**

- Class (0.5 % flow of the rated Cv value)
- Class (0.1 % flow of the rated Cv value.)

**Soft-seat:**

- Class (soft-seated shut-off valve).

According to the shut-off performance classification stated in the approved drawings, the seat leakage shall be confirmed within permissible value.

Permissible maximum leakage ( $Q_{LM}$ ) shall be as per Attachment 2.

### 5.2 Single-seated Valves, Three-way Valves

Model numbers:

HLS, HTS, HCU, HPS, HLC, HSC, HAV, HMT, HDT, VSL, VST, VTM, VTD, VAV, VAA.  
EGVT, HAF, ACP, ACN, AMT

The shut-off performance of these valves shall be applied following permissible maximum values.

**Metal-seat:**

- Class (0.01 % flow of the rated Cv value)
- Class -S1 (0.0005 % flow of the rated Cv value.)
- Class -S2 (ultra-low leakage for metal-seated)
- Class (metal-seated shut-off valve).

**Soft-seat:**

- Class (soft-seated shut-off valve).

Yamatake  Corporation	<b>INSPECTION PROCEDURE</b>	SF2-8000-0001	
	Control valve (general)	ISSUED	May.1.'98
		PAGE	7 OF 9

According to the shut-off performance classification stated in the approved drawings, the valve leakage shall be confirmed within permissible value.

Permissible maximum leakage ( $Q_{LM}$ ) shall be as per Attachment 2.

Note1. For water prohibitive valve of class , air or nitrogen gas shall be used, and test pressure shall be 350kPa(3.5kgf/cm<sup>2</sup>).

Note2. For valve which differential pressure limit is smaller than 350kPa(3.5kgf/cm<sup>2</sup>), test pressure shall be maximum operating differential pressure.

Note3. For valve which seat leakage are regulated other than above (Example. Stellite On-off valve :  $1 \times 10^{-5}$ % water flow or  $5 \times 10^{-4}$  air flow of the rated Cv value), or test pressure is less than 350 kPa(3.5kgf/cm<sup>2</sup>), permissible maximum leakage ( $Q_{LM}$ ) shall be calculated individually.

## 6.Valve Action Test

Valve action test shall be carried out for inner-valve travel, opening, closing and rated travel point, linearity of travel, hysteresis error.

Setting of signal air pressure or signal current shall be carried out using an input setter, and travel measurement shall be carried out using a dial gauge (metal scale shall be used for travel of 50 mm or over).

Measuring an input to the actuator with overrange spring shall be carried out using a precision pressure gauge.

In case of On-off valves, action test shall be carried out for only valve travel test.

### 6.1 Travel

The valve shall be confirmed to open or close smoothly on its full travel, and its maximum travel being equal to and greater than the rated travel.

However, in case of three-way valve, maximum travel tolerance shall be within  $\pm 7\%$  of the rated travel.

### 6.2 Opening, Closing and Rated Travel Point

According to Table 9 (for valves with positioner), the input signal value deviation at the valve starting to open and closing completely, shall be confirmed within tolerance.

Also the rated travel deviation shall be confirmed within tolerance.

In case of three-way valves, opening point and rated travel point shall be applied as follow.

Opening point: the input signal value which the closed port at zero signal, starts opening.

Rated travel point: the input signal value which the open port at zero

Yamatake  Corporation	<b>INSPECTION PROCEDURE</b>	SF2-8000-0001	
	Control valve (general)	ISSUED	May.1.'98
		PAGE	8 OF 9

signal, closes completely.

### 6.3 Linearity

According to Table 9(for valves with positioner), each travel deviation from its standard travel at inputs of 25, 50 and 75%, in both directions of valve opening and closing, shall be confirmed within tolerance.

For a valve with positioner being applied special unit or cam, standard values of travel and tolerance of linearity shall be as per Attachment 3.

### 6.4 Hysteresis Error

According to Table 9(for valves with positioner), differences between each travel on opening and closing at inputs of 25, 50 and 75%, shall be confirmed within tolerance.

Table 9. Tolerance of valve action with positioner(HEP.HTP.VPP.VPE)  
Unit: %FS (full scale)

Test item	Positioner input	Standard range: 20to100kPa,or4to20mA		Half split range: 1/2 of standard input	
		Standard gland type	Special type C (Note1)	Standard gland type	Special type C (Note1)
Opening point of valve travel (Note2)	Model HA1	± 2	± 4	± 4	± 6
	Except Model HA1	± 1	± 2	± 2	± 3
Rated travel point	Model HA1	± 2	± 4	± 4	± 6
	Except Model HA1	± 1	± 2	± 2	± 3
Linearity	Model HA1	± 2 ( ± 3 )	± 4 ( ± 6 )	± 4 ( ± 6 )	± 6 ( ± 8 )
	Except Model HA1	± 1	± 2	± 2	± 3
Hysteresis error	Model HA1	1	2	2	3
	Except Model HA1	1	2	2	3

<b>Yamatake</b>  <b>Corporation</b>	<b>INSPECTION PROCEDURE</b>	<b>SF2-8000-0001</b>	
	Control valve (general)	ISSUED	May.1.'98
		PAGE	9 OF 9

Figure in ( ) shows data for positioner model VPE applied.

Note1. gland type.

Special type C : Valve with formed graphite packing.  
 (Example of gland packing : T-2200, NP315)

Note2. Closing point of a valve with positioner

In case of a valve with positioner, closing point shall be confirmed with change over point of positioner output as follows.

For direct action control valve, the change over point is the signal value being up from 100% of range so that output of positioner increases to supply air pressure.

For reverse action control valve, the change over point is the signal value being down from 0% of range so that output of positioner decreases to zero.

At this condition, actuator closes valve-port overcoming to the force caused by fluid pressure, with maximum thrust.

According to Table 10, this input signal value shall be confirmed within permissible value.

**Table 10. Permissible input value for output to change over**

Valve action	Electric positioner (model : HEP)	Pneumatic positioner (model : HTP, VPE)
Direct ( from 100% value of range )	0 ~ + 1 mA	0 ~ + 10 kPa
Reverse ( from 0% value of range )	- 1 ~ 0 mA	- 10 ~ 0 kPa

6.5 In the case of AVP Positioner, refer to Attachment 4