

# ThermoPLUS

## Advanced Temperature Transmitter

### Model ATT61/71 (Integral Sensor type)

#### OVERVIEW

The models ATT61/71 Advanced Transmitter are temperature transmitters for the model ATT90 integral temperature sensor and models ATT9□ protecting wells for the temperature sensor. It converts and transmits the input signal from a thermocouple or resistance thermometer sensor into a 4 to 20mA DC or a digital signal.

CommPad (Smart Communicator) or HART<sup>®</sup> 375 communicator facilitates remote setting of various parameters, calibration or self-diagnostics.

The models ATT61/71 Transmitter, consisting of a sensor and a transmitter have been certified to conform with the TIS Flameproof structure standard. For this reason, use of Yamatake's Model ATT sensor are highly recommended.

#### FEATURES

1. Vastly improves maintenance efficiency. CommPad facilitates setting, calibration and self-diagnostics of the transmitter from the control room
2. Reduces transmitter inventory  
Single model accepts wide range of sensor types.
3. Reduces installation costs.  
Two-wire system eliminates the need for compensating lead wire or three-core shield cable from site to control room.
4. Self-diagnostic functions facilitates simple operation:
  - Abnormal ambient temperature:  
If deviates from the range of -40 to +85°C  
(Current ambient temperature can be monitored)
  - Abnormal cold junction: If platinum temperature sensor for cold junction becomes abnormal
  - Abnormal input:  
If temperature sensor output shows irregularity
  - Open thermocouple wire:  
If thermocouple wire becomes open
5. An optimal range for process operation can be selected.  
The maximum/minimum holding function allows read-out if the range is exceeded.
6. Useful integral indicator  
Integral digital indicator provides both field indication and signal transmission.
7. Explosion-proof model can be used in an acetylene or a hydrogen atmosphere  
The transmitter has been certified for TIS Flameproof, Ex d IIC T6.

**Note) \*1** External appearance may differ from those shown in the photographs in this Specification Sheet depending on type of sensors used.

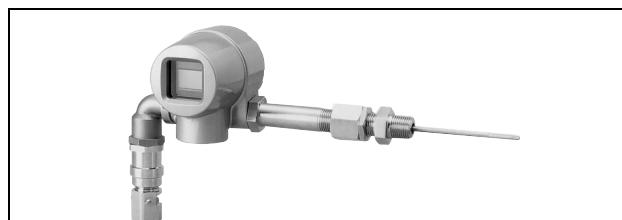

Combination of ATT71 temperature transmitter and ATT90 temperature sensor (Sold separately) \*1

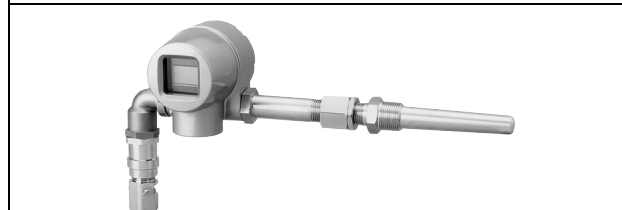

Combination of ATT71 temperature transmitter and ATT90 temperature sensor with ATT92 sensor protecting well (Sold separately) \*1

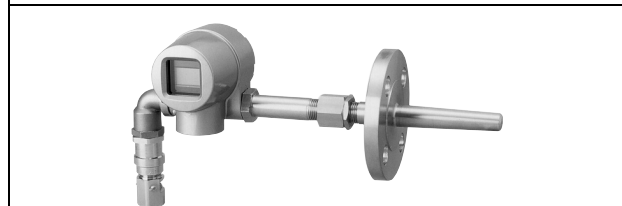

Combination of Temperature Transmitter ATT71, Temperature Sensor ATT90 (Sold separately) with Sensor Protecting Well ATT95 (Sold separately) \*1



CommPad (Sold separately)

#### China RoHS

This device is used in the Oil & Gas, Petrochemical, Chemical, Pulp & Paper, Food & Beverage, Machinery, Steel/Metal & Mining, and Automobile industries and therefore does not fall under the China RoHS Legislation. If this device is used in semiconductor manufacturing equipment, labeling on the device and documents for the China RoHS may be required. If such documents are required, consult a Yamatake representative.

HART<sup>®</sup> is a registered trademark of the HART Communication Foundation.

**STANDARD SPECIFICATIONS**

**Converter**

**Input**

**Thermocouple (T/C)**

SJ(J), SK(K), ST(T),SE(E)

**Resistance thermometer sensor (RTD)**

Pt100

mV

**Measurable range**

**Thermocouples (T/C) and Resistance thermometer sensor (RTD)**

All temperature ranges listed in official JIS Table (For details, refer to Table 1)

mV

-20 to 120mV

**Burnout**

Up-scale (over 21.2mA DC) or down-scale (under 3.6mA DC)

**Cold junction compensation**

Internal/External cold junction compensation (selected by CommPad)

**Cold junction compensation accuracy**

±0.5°C

**Conversion accuracy**

Depends on the sensor type and measurement span. (For details refer to Table 2.)

**Output**

Analog output (4 to 20 mA DC) or Digital output (DE protocol)

**Built-in indicating meter**

An optional LCD display is in 4.5-digit (-1999.9 to 1999.9) with an engineering unit (degree C, degree F, mV) including 0-100% bar graph.

**Supply voltage and load resistance**

17.5 to 42V DC/250 to 1271 Ω (For details, refer to Figure 1)

**Input/output insulation**

500V AC

**Ambient temperature limits**

Waterproof model:

Without LCD display: -40 to 85°C

With LCD display: -20 to 70°C

TIIS Flameproof model:

-20 to 60°C

**Ambient humidity limits**

5 to 100% RH

**Vibration tolerance**

5 to 9 Hz 0 to 7.5mmp-p

9 to 2000 Hz 0 to 29.4m/s<sup>2</sup> (3G)

**Additional characteristics**

**Influence of ambient temperature**

±0.5% F.S. (30°C)

**Influence of ambient humidity**

±0.01%F.S. (5 to 100% RH)

**Influence of power supply voltage**

±0.1%F.S. (@17 to 42V DC)

**Construction**

**Case**

Aluminum alloy

**Waterproof model**

JIS C0920 immersion-proof

NEMA Type 4X, IEC IP67

**TIIS Flameproof model**

TIIS Flameproof Ex d IIC T6 (Ambient temperature

-20 to 60°C)

**Installation**

Horizontal or on 2 in. vertical pipe pedestal

**Color**

Metallic green (Munsell 5G7/8)

**Weight**

Approx. 830g (with integral LCD, without sensor and bracket)

**Setting at factory shipment (All settings can be modified with CommPad)**

**Sensor type**

Pt100 (by specifying 'C' of additional specifications)

**Temperature range**

0 to 100 °C (by specifying 'C' of additional specifications)

**TAG No.**

XXXXXXXX (by specifying 'C' of additional specifications)

**Output characteristics**

Linear

**Damping time**

0.0sec

**Cold junction compensation**

Internal cold junction

**Table 1 Measurable range**

Type of sensor	Guaranteed accuracy range *1	CommPad's setting range *2	Applicable standards
SJ(J)	-50 to 1200°C	-200 to 1200°C	JIS C1605-1995
SK(K)	-170 to 1250°C	-200 to 1370°C	
ST(T)	-120 to 400°C	-250 to 400°C	
SE(E)	-100 to 1000°C	-200 to 1000°C	
Pt100	-200 to 850°C	-200 to 850°C	JIS C1604-1997
mV	-20 to 120mV	-10 to 120mV	--

Note) 1. Guaranteed accuracy means the range of signal conversion that is guaranteed. Measurable range is governed by sensor that is used.

Note) 2. CommPad's setting range is the output range that can be set by CommPad.

Table 2 Conversion accuracy

Type of sensor	Digital accuracy	Internal cold junction compensation accuracy	Analog accuracy	Minimum span
SJ(J)	±0.3 °C	±0.5°C	±0.05%F.S.	25°C
SK(K)	±0.4 °C			
ST(T)	±0.4 °C			
SE(E)	±0.3 °C			
Pt100	±0.2 °C	Not required		10°C
mV	±0.05%rdg, or ±50μV, whichever is larger		2mV	

Note) \* Overall accuracy = Digital accuracy + analog accuracy  
 (For digital output type, only digital accuracy applies.)

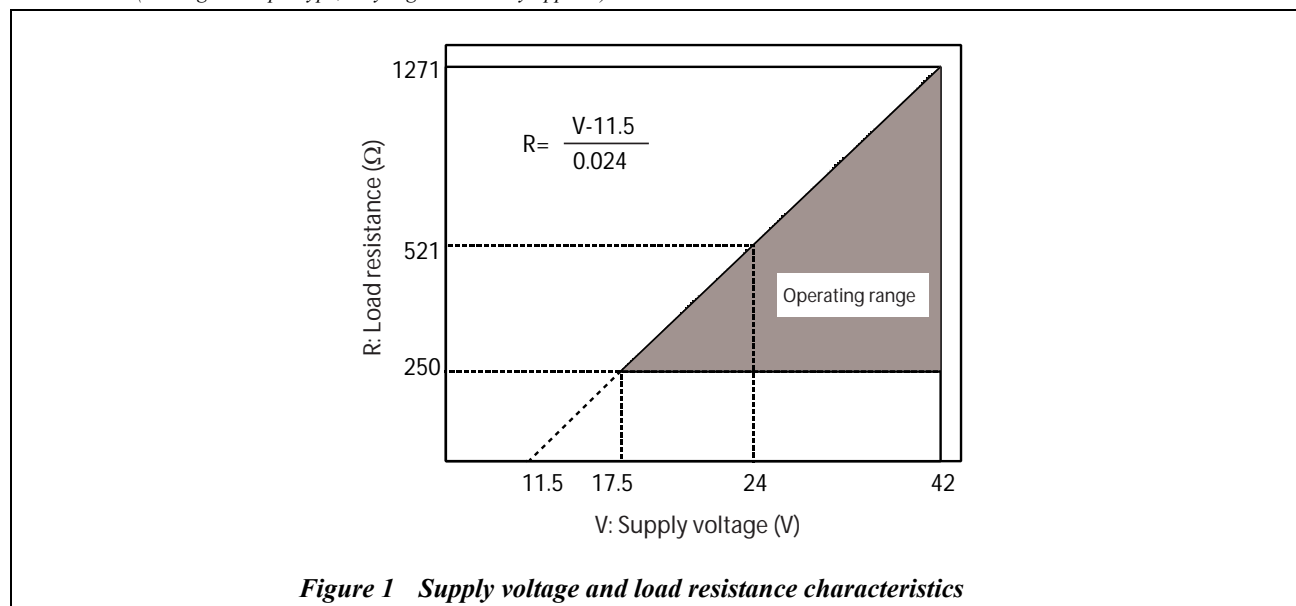

Figure 1 Supply voltage and load resistance characteristics

**Example of accuracy calculation**

When the models ATT61/71 are used with an model ATT90 sensor (sold separately) the maximum error and accuracy can be calculated as follows:  
 Both models ATT61/71 and model ATT90 have their own integral errors. When they are integrated, the total sum of the errors must be taken into consideration.  
 Each temperature sensor's error differs one from the other, depending on type of sensor, measuring location and class. Refer to our model ATT90 Sensor's Specifications. If another manufacturer's sensor is used with the model ATT61, please inquire of the accuracy with that sensor's manufacturer.

• **Calculation of maximum error when SN (N) thermocouple range is set at 0 to 1000°C analog output**

[Converter error]

$$\begin{aligned} \text{Converter accuracy} &= \text{digital accuracy} + \text{analog accuracy} \\ &\quad + \text{internal cold junction compensator accuracy} \\ &= 0.5 + 1000 \times 0.05\% \text{ F.S.} + 0.5 \\ &= 0.5 + 0.5 + 0.5 \\ &= 1.5 \text{ (}^\circ\text{C)} \end{aligned}$$

Hence the maximum converter error is within +1.5 °C.  
 (Accuracy is  $1.5/1000 \times 100 = 0.15\%$  F.S.)

[Temperature sensor error]

<ul style="list-style-type: none"> <li>• Type of thermocouple: SN(N)</li> <li>• Class:2</li> <li>• Operating temperature range: 1000 °C</li> </ul>	From model ATT90 Specifications $\Rightarrow + 0.0075   t  $ $+ 0.0075 \times 1000$ $= +7.5 \text{ (}^\circ\text{C)}$
--	--

[Overall error]

$$\begin{aligned} \text{Overall error} &= \text{Converter error} + \text{temperature sensor error} \\ &= 1.5 + 7.5 \\ &= 9.0 \text{ (}^\circ\text{C)} \end{aligned}$$

The overall maximum error for a combination of a converter and sensor is approximately +9°C.  
 (Overall accuracy is  $+ 9.0/1000 \times 100 = 0.9\%$  F.S.)

• **Calculation of maximum analog output error when Pt100 resistance thermometer sensor range is set at -20 to 80°C analog output**

[Converter error]

$$\begin{aligned} \text{Converter accuracy} &= \text{digital accuracy} + \text{analog accuracy} + \text{internal cold junction compensator accuracy} \\ &= 0.2 + 100 \times 0.05\% \text{ F.S.} + 0 \\ &= 0.2 + 0.05 + 0 \\ &= 0.25 \text{ (}^\circ\text{C)} \end{aligned}$$

Hence, the maximum converter error is  $\pm 0.25^\circ\text{C}$   
 (Overall accuracy is  $0.25/100 \times 100 = 0.25\%$  F.S.)

[Temperature sensor error]

<ul style="list-style-type: none"> <li>• Resistance temperature detector: Pt100</li> <li>• Class: A</li> <li>• Temperature range 100°C</li> </ul>	From model ATT90 Specifications, $\Rightarrow \pm 0.15 + 0.002   t  $ ; $\pm 0.15 + 0.002 \times 100$ $= \pm 0.35 \text{ (}^\circ\text{C)}$
---	--

[Overall accuracy]

$$\begin{aligned} \text{Overall accuracy} &= \text{Converter error} + \text{temperature sensor error} \\ &= 0.25 + 0.35 \\ &= 0.6 \text{ (}^\circ\text{C)} \end{aligned}$$

Hence, the maximum converter and sensor combination error is under  $\pm 0.6^\circ\text{C}$ .  
 (Overall accuracy is  $0.6/100 \times 100 = 0.6\%$  F.S.)

• **Calculation of maximum digital output error when Pt100 resistance thermometer sensor range is set at 0 to 200 °C analog output**

[Converter error]

$$\begin{aligned} \text{Converter accuracy} &= \text{digital accuracy} + \text{analog accuracy} + \text{internal cold junction compensator accuracy} \\ &(\rightarrow \text{No analog error because output is digital}) \\ &= 0.2 + 0 + 0 \\ &= 0.2 \end{aligned}$$

The maximum error is under  $\pm 2^\circ\text{C}$   
 (Accuracy is  $0.2/100 \times 100 = 0.2\%$  F.S.)

[Temperature sensor error]

<ul style="list-style-type: none"> <li>• Resistance temperature detector: Pt100</li> <li>• Class: B</li> <li>• Temperature range 200°C</li> </ul>	From model ATT90 Specifications, $\Rightarrow + 0.3 + 0.005   t  $ ; $0.3 + 0.005 \times 200$ $= 1.3 \text{ (}^\circ\text{C)}$
---	---

[Overall error]

$$\begin{aligned} \text{Overall error} &= \text{converter error} + \text{temperature sensor error} \\ &= 0.2 + 1.3 \\ &= 1.5 \text{ (}^\circ\text{C)} \end{aligned}$$

The maximum overall error for a combination of a converter and temperature sensor is under +1.5°C.  
 (Overall accuracy is  $1.5/200 \times 100 = 0.75\%$  F.S.)

## Explanation of converter model number symbols

### Standard model number

ATT61 Waterproof models (integral type)

ATT71 Explosion-proof models (integral type)

### Selectable specifications

#### Output type

A 4 to 20 mA DC analog

D DE protocol

H 4 to 20 mA DC analog with HART® communication

#### Construction

Case: Aluminum alloy

1 Waterproof: JISC0920 immersion-proof NEMA3 and 4X, IEC IP67

2 TIIS Flameproof: Ex d IIC T6 (Ambient temperature -20 to 60°C)

#### Electric conduit

1 G1/2 thread

6 1/2 NPT (for adaptor)

7 M20\*1.5 thread (for adaptor)

8 Pg13.5 thread (for adaptor)

### Additional specification selection

#### Integral indicator

X No indicator

M Digital indicator (°C)

Digital indication: 4.5 digits -1999.9 to 1999.9°C

Plus 4 to 20mADC level bar graph indication

Self-diagnostic status

F Digital indicator (°F)

Digital indication: 4.5 digits -1999.9 to 1999.9°C

Plus 4 to 20mADC level bar graph indication

Self-diagnostic status

#### Painting

S Standard finish

Baked acrylic resin

A Corrosion-proof paint

Baked acrylic resin, fungus proof finish

B Corrosion-proof paint

Baked epoxy resin, fungus proof finish

#### Direction of burn-out

U Upscale on failure

D Downscale on failure

### Additional specifications

A Traceability certificate

This certificate consists of three copies of the measurement management system's block diagram, calibration certificate, and test report.

B 2-inch pipe mounting bracket

Can be mounted either horizontally or vertically

C Customer configurations

Type of sensor, range setting, Tag. No. (Engraved on name plate and written into EEPROM in eight alpha numerical characters) before shipment. Please specify setting when ordering.

E One electric conduit elbow

One elbow is provided to direct the explosion-proof cable gland and cable downward.

Material: brass, Wire diameter: Ø9 to 12

T Calibration test report

This test report covers testing such as for external appearance, insulation resistance, and voltage withstanding, input/output characteristics. Since input/output test of thermocouple input model and mV input model are identical, the test is conducted with mV input. Note that this test is for the temperature transmitter itself and not for the integrated temperature transmitter-sensor test.

## Other common specifications

### Lightning guard specifications

Voltage surge peak amplitude: 100kV

Current surge peak amplitude: 1000A

### Anti-vibration specifications

5 to 9Hz 0 to 7.5 mmp-p

9 to 2000Hz 0 to 29.4 m/s<sup>2</sup>

*Note) Product specifications except sensor and bracket*

### Finish

Metallic green (Munsell 5G7/8)

## Cautions regarding product selection

- TIIS Flameproof construction consists of temperature transmitter itself and temperature sensor. When specifying a TIIS Flameproof model, please order a Yamatake Temperature sensor model ATT90. Also, please use a protecting well to protect temperature sheath.
- According to the 'TIIS Flameproof Technical Standard (February 1997)' the ambient temperature should be -20 to 60°C, and applicable range for explosion-proof is -20 to 85°C. Also, explosion-proof standards can be ensured of by using a explosion-proof packing type cable gland. If cable glands of other makes are incorporated, Yamatake cannot guarantee that the unit will comply to explosion-proof standards.
- Even though ambient temperature is within the specified range, heat may accumulate in converter. If this occurs, provide a shield to keep the converter temperature within the specified range.

**MODEL SELECTION**

**Model ATT61 Waterproof model**

Basic Model No.

**ATT61** -

		Selection1	Selection2	Option
Output	Analog (4 to 20 mA)	A		
	Digital (DE -protocol)	D		
	Analog (4 to 20 mA) with HART <sup>®</sup> communication	H		
Housing	Waterproof and dust -proof structure	1		
Electrical connection	G1 / 2	1		
	1/2NPT (with adaptor)	6		
	M20 × 1.5 (with adaptor)	7		
	Pg13.5 (with adaptor)	8		
Integral digital meter	Without		X	
	LCD meter for Deg. C *1		M	
	LCD meter for Deg. F *1		F	
Finish	Standard finish		S	
	Corrosion -resistant finish		A	
	Corrosion -proof finish		B	
Burnout feature	Upscale		U	
	Downscale		D	
Options *2	No selection			X
	Certificate of traceability			A
	Mounting bracket			B
	Customer configurations (sensor type and measuring range) *3			C
	One elbow for electrical conduit *4			E
	Calibration test report			T

Note) \*1. If sensor type is “mV”, LCD meter displays “mV” as engineering unit.

\*2. Up to five options may be selected simultaneously.

\*3. If it is required to configure sensor type, range and tag No. at the ex factory, please select “C” and specified specifications separately. If there is no specified specification, the unit will be configured with the default value.

\*4. Only applicable for the G1/2 “code 1” in the Electrical connection.

## Model ATT71 Explosion-proof model

Basic Model No.		Selection1		Selection2		Option		
ATT71								
Output	Analog (4 -20mA)	A						
	Digital (DE -protocol)	D						
	Analog (4 -20mA) with HART® communication	H						
Housing	TIIS Flameproof *1		2					
Electrical connection	G1 / 2							1
Integral digital meter	Without				X			
	LCD meter for Deg. C *2				M			
	LCD meter for Deg. F *2				F			
Finish	Standard finish				S			
	Corrosion -resistant finish				A			
	Corrosion -proof finish				B			
Burnout feature	Upscale							U
	Downscale							D
Options *3	No selection							X
	Certificate of conformance and origin							A
	Mounting bracket							B
	Customer configurations (sensor type and measuring range) *4							C
	One elbow for electrical conduit							E
	Calibration test report							T

Note) \*1. Use model ATT90 (sold separately) for the temperature sensor. TIIS Flameproof construction consists of temperature transmitter itself and temperature sensor.

\*2. If sensor type is "mV", LCD meter displays "mV" as engineering unit.

\*3. Up to five options may be selected simultaneously.

\*4. If it is required to configure the sensor type, range and tag No. at the ex factory, please select "C" and the specified specifications separately. If there is no specified specification, the unit will be configured with the default value.

# DIMENSIONS

## External dimensions

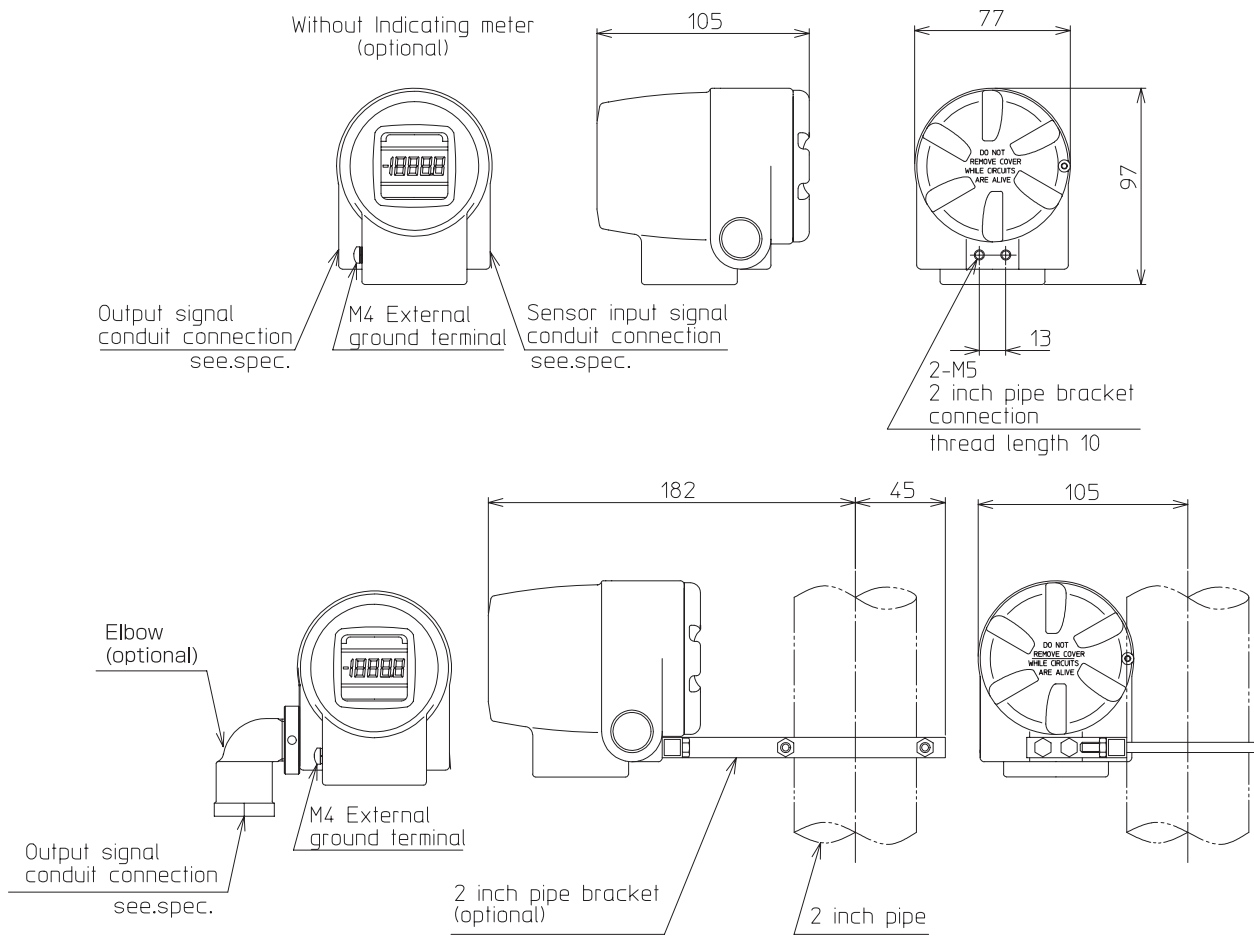

### Output wiring

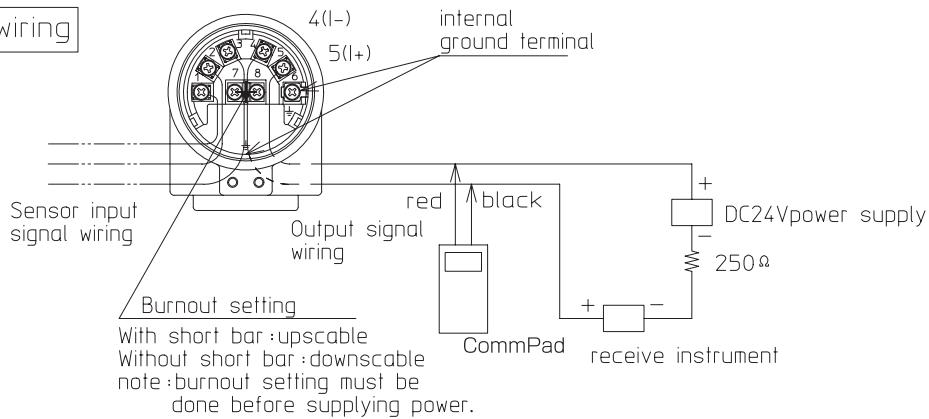

note : terminal screws are M4

**Caution:**  
The above drawing are of the external appearance of ATT61/71. For external appearance with sensor, refer to ATT90 specification, SS2-ATT900-0100.

Specifications are subject to change without notice.

**azbil**

**Yamatake Corporation**  
**Advanced Automation Company**

1-12-2 Kawana, Fujisawa-shi  
Kanagawa-ken 251-8522 Japan

URL: <http://www.azbil.com>

No part of this publication may be reproduced or duplicated without the prior written permission of Yamatake Corporation.

Oct. 2006-Y/Y  
May. 2009 (rev.2)-Y/Y