

Harmonas-FLeX

Harmonas-FLeX Distributed controller

1. Introduction

The Harmonas-FLeX Distributed controller (FLC) is a compact controller designed to be installed in a local control panel. The FLC has the following functions and features:

■ Control

- The FLC has functions equivalent to those of yamatake's DCS process controllers.
It can be used for executing both PID control and sequence control and it is provided with various functions.
- Control program generation and maintenance can be performed with the integrated engineering environment (RTC). Debugging can be performed easily by using a FLC virtual simulation software runs on a personal computer.
- Control programs can be represented with logic charts using the function block for easy tracing.
Generated programs can be displayed in the form of drawings.

■ Installation

- Compact type controller that can be installed in a small-size box (400 × 400 mm).
Mountable on an existing control cabinet or wall-mounted box.
- Built-in field power supply and power supply wiring for field device signal and short protection circuit.
As it may be connected directly with the field wiring, installation is completed by just installing FLC and connecting the power supply with the field wiring.
- 368 input/output points at the maximum (approximately 256 points with a usual combination).
Various input/output types can be combined in accordance with the application.
- Environment-endurable design that allows operation in an encapsulated box.

■ System Compatibility

- Redundant Ethernet ports are equipped for standard specifications.
- A programmable smart terminal EST555Z can be connected to perform graphic operation and collecting and storing data.
This system can be used as a digital recorder.
- Integrated to a system such as the Harmonized automation system Harmonas-DEO by connecting a Ethernet cable. The FLC can be installed in each local control panel individually, making stepwise networking and systemization possible.

Note: Refer to CP-SS-1800 for the specification sheet of the programmable indicator "EST555Z".



Figure 1. Example of Installation in a Box



Figure 2. EST555Z

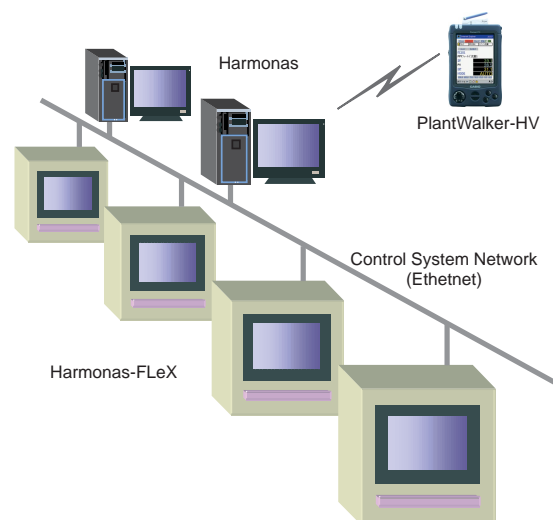

Figure 3. System Architecture

2. Functional Overview

The FLC consists of a main unit and three expansion units at the maximum, and each unit has 6 I/O slots to mount I/O cards. When using an expansion unit, mount an interface card for the expansion unit to an I/O slot of the main unit, and mount similarly an interface card for interfacing with the main unit to each expansion unit, and connect them with a dedicated cable ^(*). The remaining I/O cards can be selected from with the following cards of the necessary number and mounted.

- AI [4 to 20 mA/1 to 5 VDC] : 8 points/card
- Thermocouple mV input[Thermocouple input/-100 to 100mV] : 4 points/card
- AO [4 to 20 mA] : 8 points/card

*1: The interface card in each expansion unit does not require an I/O slot, which resides in a control card slot instead as the I/O expansion units do not require the control card.

- RTD : 8 points/card (Air-conditioning specification), 4 points/card (Free range)
- Pulse input : 8 points/card
- DI : 16 points/card
- DI [Relay input] : 16 points/card
- DO [Semiconductor output] : 16 points/card
- DO [Relay output] : 16 points/card
- EST I/F : 1 port/card (Mounted to the main unit.)

In addition, Ethernet is adopted for the control network and connection to other systems such as the Harmonized automation system Harmonas-DEO, and information systems. The control network is provided with a redundant port for the standard specification. A single configuration of Ethernet is also available.

■ Specifications

Table 1. Hardware Specifications

Item	Specifications
CPU	32 bits
Number of I/O points	Largest configuration when three expansion units are connected - 23 I/O cards at the maximum (When the EST is connected, 22 cards at the maximum.) - HLAI: 184 points (maximum), 8 points/card - Thermocouple mV input: 92 points (maximum), 4 points/card - RTD AI for room temperature: 184 points (maximum), 8 points/card, fixed range of - 20 to 80°C - RTD AI: 92 points (maximum), 4 points/card, free range - AO: 184 points (maximum), 8 points/card - DI: 368 points (maximum), 16 points/card - DO: 368 points (maximum), 16 points/card - Pulse input: 184 points (maximum), 8 points/card Note: The maximum number of points shown above is the restriction for the mounted slots when three expansion base units are connected. A certain restriction on the number of cards for practical use may be given from the control functional performance point of view. Configuration with only the main unit - 6 I/O cards (5 cards if the EST is connected.)
Weight	Approximately 4 kg
Power supply specification	100 VAC ±10%, 50 or 60 Hz
Grounding	D-type grounding
Power consumption	FLC (built-in power supply for field: 2.2 A) 150VA FLC (field power supply, external type) 50 VA

Table 2. Specifications for Communication

Item	Specifications
Host communication (Harmonas-DEO system, etc.)	Ethernet 10 Mbps, 400 PPS at the maximum (parameter/second: 400 PPS in total with communication between controllers)
Communication between controllers	Available through Ethernet, 400 PPS at the maximum (parameter/second: 400 PPS in total with host communication)
I/O communication	Dedicated parallel bus (An I/O slot of the main unit is occupied for the interface with the expansion units. No occupancy on the expansion unit side.)
Flat panel display (EST) communication	1:1 communication with the controller through RS232 or RS485 Models that can be connected is EST555Z. (An I/O slot of the main unit is occupied for the interface.)

Table 3. Software Specifications

Item	Specifications
Regulatory control point	Regulatory control point: 32 points Regulatory PV point: 32 points
Regulatory control algorithm	19 types (48 formulas)
Control cycle	Select the basic cycle from 0.1, 0.2, 0.5 and 1 second (CL is fixed to 1 second.) Partly, 0.1 second execution processing is possible (CL is also possible.)
Sequence	128 CL programs (Maximum) * CL: Control Language 6080 MU: 18240 - 24480 CL statements (The CL memory has no relation with other functions and can be used as a dedicated memory.)
Logic	64 points 1024 blocks at the maximum, 16 blocks at the maximum for each Logic Point. 25 algorithms
SAMA function block	128 points at the maximum 2048 blocks at the maximum 91 algorithms (When monitoring from the Harmonas-DEO Supervisory Station and/or EST is necessary, values and/or status of block calculations are allocated to the numeric variables or the flag variables.)
Digital composite	256 points at the maximum
Numeric value variable	8192(Note 1) + 80×(number of sequences used) points
Flag variable	8192(Note 2) + 128×(number of sequences used) points
Timer variable	32 points

Note 1: 3,000 points are for use by the user, and the rest is reserved for the system.

Note 2: 3,000 points (including 512 for alarm) are for use by the user, and the rest is reserved for the system.

■ Installation environment conditions

Installation environment conditions for an FLC installation are shown in the following table. For an FLC installation, provide clearances of the specified dimensions around the main unit.

In addition to the following conditions, pay appropriate attention to the external magnetic field, electrostatic discharge, radio interference, etc.

Table 4. Installation Environment Conditions

Item		Standard operating conditions	Normal operating conditions	Marginal operating conditions	Conditions for storage and transportation
Ambient temperature (Note 1)	Range (°C)	23 ± 2	0 to 50	0 to 50	0 to 50
	Rate of change (°C/h)	± 5	± 20	± 20	-
Relative humidity	(% RH)	50 ± 10	5 to 95 (0.020kg/kg') ^{Note2}	5 to 95 (0.020kg/kg')	5 to 95 (0.020kg/kg')
Vibration (Note 3)	Amplitude	0	0.35 mm or lower (2 to 9 Hz)	0.35 mm or lower (2 to 9 Hz)	1.5 mm or lower (2 to 9 Hz)
	Acceleration	0	1m/s ² or lower (9 to 150 Hz)	1m/s ² or lower (9 to 150 Hz)	5m/s ² or lower (9 to 150 Hz)

Note 1: The atmosphere for use shall not include any corrosive gas. It is recommended to install in the control panel with a temperature of 45°C or lower.

Note 2: Maximum relative humidity (ratio of mass, kg/kg between wet air and dry air)

Note 3: Do not install in a place in which strong vibration is applied continuously.

■ Input and output specifications

Table 5. Input and Output Specifications

Item		Specifications
Analog input	Number of points	8 points/card
	Input power supply voltage and consumption current	24 VDC $\pm 10\%$, 70 mA (When the transmitter* power supply is not used.)
	Input signal	1 to 5 VDC (0 to 100%)
	Input range (FS)	0.726 to 5.276 VDC (- 6.9 to 106.9%)
	Accuracy	0.5% F.S. (factory-shipped adjustment, under the environment of 25°C $\pm 2^\circ\text{C}$)
	Repeatability	0.5% F.S.
	Insulation	Common isolation with the input power supply and system power supply Differential input for use between channels (allowable operating voltage ± 3 V)
	Input impedance	1 M Ω or higher
	Transmitter power supply	18.6 to 26.4 VDC, 200 mA or more at the maximum (8 points common, prepared for each card)
Thermocouple mV input	Number of points	4 points/card
	Input supply voltage, Consumption current	24 VDC $\pm 10\%$, 50 mA
	Input circuit	Isolation per point
	Input signal	Thermocouple input: Refer to the table 6 below mV input: -100 to 100 mV
	Cold contact compensation precision	$\pm 0.5^\circ\text{C}$ (in an environment of 25°C)
	Conversion reference precision	mV input: $\pm 20\ \mu\text{V}$ Thermocouple input: Refer to the table 6 below
	Influence by temperature change	Thermocouple input: Based on FLC environmental temperature = 25°C, as the additional precision add the result of the calculation by the following formula to the conversion reference precision. T1 = FLC environmental temperature (°C) T2 = Conversion reference precision = Corresponding value in the table 6 "Thermocouple Type and Conversion Reference Precision" Conversion precision = Conversion reference precision (T2) $\pm T2 * (T1 - 25)/15$
	Withstand voltage	500 VAC (between input channels, and between input and field power supply)
	Common mode rejection ratio (CMRR)	120 dB or more (DC to 60 Hz)
	Normal mode rejection ratio (NMRR)	40 dB or more (50 Hz/60 Hz)
	Scan cycle	1 second
	Open circuit detection (OTD)	Upscale or downscale, selectable Per point
	Input impedance	1 M Ω or more
	RTD input: free range (Resistance temperature sensor input)	Number of points
Input supply voltage, Consumption current		24 VDC $\pm 10\%$, 50 mA
Input circuit		Isolation per point
Input signal		Pt 100 Ω , variable range
Conversion reference precision		$\pm 0.8^\circ\text{C}$
Influence by temperature change		Based on FLC environmental temperature = 25°C, as the additional precision add $\pm 0.8 / 25^\circ\text{C} \pm 15^\circ\text{C}$ to the conversion reference precision with the result of the calculation by the following formula. T = FLC environmental temperature (°C) Conversion precision = conversion reference precision ($\pm 0.8^\circ\text{C}$) $\pm 0.8^\circ\text{C} * (T - 25)/15$
Allowable wiring resistance		Maximum 20 Ω
Difference in resistance values of wiring		Since this becomes the temperature measurement error, make the difference of the resistance value small.
Withstand voltage		500 VAC (between the input and SG)
Common mode rejection ratio (CMRR)		110 dB or more (DC to 60 Hz)
Normal mode rejection ratio (NMRR)		40 dB or more (50 Hz/60 Hz)
Scan cycle		1 second
Input impedance		1 M Ω or more
Temperature input (Room temperature, outside air temperature, etc.)	Number of points	8 points
	Input power supply voltage and consumption current	24 VDC $\pm 10\%$, 70 mA
	Input signal	PT 100 Ω , - 20 to 80°C , fixed range
	Accuracy	1% F.S. (under the environment of 25°C $\pm 2^\circ\text{C}$)
	Isolation	Common isolation with the input power supply and system power supply
	Allowable wiring resistance	5 Ω or lower
Analog output	Number of points	8 points/card
	Output power supply voltage and consumption current	24 VDC $\pm 10\%$, 140 mA (at 100% output on all points)
	Output range	4 to 20 mA (0 to 100%)
	Output scope	2.9 to 21.1 mA (- 6.9% to 106.9%)
	Accuracy	0.5% F.S. (factory-shipped adjustment, under the environment of 25°C $\pm 2^\circ\text{C}$)
	Repeatability	0.5% F.S.
	Isolation	Common isolation with the input power supply and system power supply
	Maximum load resistance	300 Ω

*Remarks: The transmitter power supply is not insulated from the input power supply.
When the transmitter power supply is used, the minus input becomes common and differential input cannot be performed.
When connecting a two-wire transmitter or 4 to 20 mA input, install a 250 Ω resistor to the external terminal.

Table 5-2. Input and Output Specifications (Continued)

Item		Specifications
Pulse input	Number of points	8 points/card
	Input circuit	Photocoupler input (source or sink are selectable by card)
	Common	8 points common
	Input supply voltage, Consumption current	24 VDC \pm 10%, 50 mA (when all points are ON)
	Input signal	On: 13 V or more (12 mA or more) Off: 4 V or less (1.2 mA or less)
	Input impedance	1.5 k Ω
	Input range	HI : 0 to 5 kHz LO: 0 to 20 Hz
	Minimum pulse width	Input range HI : 0 to 5 kHz, ON \geq 0.1 ms, OFF \geq 0.1 ms. Input range LO: 0 to 20 Hz, ON \geq 25 ms, OFF \geq 25 ms.
Digital input	Isolation	Isolated with the system power supply, not isolated with the input power supply
	Number of points	16 points/card
	Input circuit	Photocoupler input (source or sink are selectable by card)
	Common	16 points common
	Input power supply voltage and consumption current	24 VDC \pm 10%, 100 mA (When all points are ON.)
	Input signal	ON: 18 V or higher (2.4 mA or higher) OFF: 6 V or lower (0.8 mA or lower)
	Input impedance	6.8 k Ω
	Input filter time constant	10 ms
	Isolation	Isolated from the system power supply and not isolated from input power supply
	Input type	Status-type, or latch-type (push button) input or counter-type Specifiable for each point (depending on the software)
	Latch type DI input detection width	100 ms or more
Integratable pulse width	100 ms or more (200 ms or higher at ON/OFF)	
Digital input (Connected to the Omron G7TC)	Number of points	16 points/card
	Input circuit	With the relay used for the Omron G7TC
	Common	
	Input supply voltage, Consumption current	24 VDC \pm 10%, 100 mA Do not feed power to the Omron G7TC from the FLC power supply. Not isolated.
	Input signal	
	Input impedance	With the relay used for the Omron G7TC
	Input filter time constant	
	Isolation	The I/O card side is isolated with the system power supply. With the relay used for the Omron G7TC
	Input type	Status-type input, latch-type (push-button type) input or counter-type input Specifiable for each point (by software)
	Latch-type DI input detector	100 ms or more
	Integrating pulse width	100 ms or more (200 ms or more for on and off)
Digital output	Number of points	16 points/card
	Output circuit	Open collector
	Common	16 points common
	Output power supply voltage and consumption current	24 VDC \pm 10%, 10 mA (When all points are OFF.)
	Maximum key current (load current)	Maximum 0.5 A (for one point) Maximum 2 A (for one card)
	Output transistor ON voltage	1.5 V or lower (When the load current is 0.5 A.)
	Isolation	Isolated from the system power supply and not isolated from the output power supply
	Output type	Latch-type (status) output or pulse-type output, specifiable for output of each point (Depending on the software)
	Pulse-type DO pulse width	100 ms to 120 s, 100 ms resolution
Digital output (Connected to the Omron G7TC)	Number of points	16 points/card
	Output circuit	With the relay used for the Omron G7TC
	Supply voltage for output, Consumption current	24 VDC \pm 10%, 10 mA (excluding power supply to the Omron G7TC) 24 VDC \pm 10%, 400 mA (supplying power to the Omron G7TC, relays 16 points excited) Note
	Contact rating	
	Operation time	With the relay used for the Omron G7TC
	Reset	
	Isolation	The I/O card side is isolated with the system power supply. The Omron G7TC side depends on the used relay.
Output type, pulse width	Same as open collector input	

Note: Limit the number of digital output cards (connected to the Omron G7TC) when power is supplied from the FLC power supply to the Omron G7TC to 4 cards/unit at the maximum.

Table 6. Thermocouple Type and Conversion Reference Precision

Thermocouple Type	Input Temperature	Precision
T	-200 to 0 °C	$\pm(1.0 - 0.005 * \text{Input Temperature}) \text{ } ^\circ\text{C}$
	0 to 350 °C	$\pm 0.5 \text{ } ^\circ\text{C}$
J	-100 to 0 °C	$\pm(1.0 - 0.005 * \text{Input Temperature}) \text{ } ^\circ\text{C}$
	0 to 1100 °C	$\pm 0.5 \text{ } ^\circ\text{C}$
E	-200 to 0 °C	$\pm(1.0 - 0.005 * \text{Input Temperature}) \text{ } ^\circ\text{C}$
	0 to 900 °C	$\pm 0.5 \text{ } ^\circ\text{C}$
K	-200 to 0 °C	$\pm(1.0 - 0.005 * \text{Input Temperature}) \text{ } ^\circ\text{C}$
	0 to 1300 °C	$\pm 0.5 \text{ } ^\circ\text{C}$
R	0 to 400 °C	$\pm 3.0 \text{ } ^\circ\text{C}$
	400 to 1600 °C	$\pm 2.0 \text{ } ^\circ\text{C}$
S	0 to 300 °C	$\pm 3.0 \text{ } ^\circ\text{C}$
	300 to 1700 °C	$\pm 2.0 \text{ } ^\circ\text{C}$
R	0 to 100 °C	$\pm 3.0 \text{ } ^\circ\text{C}$
	100 to 1770 °C	$\pm 2.0 \text{ } ^\circ\text{C}$

The above precisions do not include cold junction compensation precision ($\pm 0.5 \text{ } ^\circ\text{C}$).

■ **Model**

Table 7. List of Models

varnish finished	Model	Name	Remarks
*	HD-FXFLC00P	Main unit: With field power supply	Controller main unit (Either one shall be selected.)
*	HD-FXFLC00PE	Main unit: With field power supply + With expansion unit I/F board	
*	HD-FXFLC00N	Main unit: Without field power supply	
*	HD-FXFLC00NE	Main unit: Without field power supply + With expansion unit I/F board	
	HD-FXSWFLC20	FLC license	Necessary for each main unit
*	HD-FXFLE00P	Expansion unit: With field power supply	Controller expansion unit (Either one shall be selected.)
*	HD-FXFLE00N	Expansion unit: Without field power supply	
*	HD-FXDCBX00	Expansion unit I/F board (3 ports on the main unit side)	Necessary when connecting an expansion unit to the main unit without an expansion unit I/F
	HD-FXEXPNL	Front panel for connecting the expansion unit (A part on the main unit side)	
	HD-FXCBL01	Expansion unit connection cable: 1 m	Necessary when using expansion unit
	HD-FXCBL02	Expansion unit connection cable: 2 m	
	HD-FXCBL03	Expansion unit connection cable: 3 m	
*	HD-FXAIPS00	Analog input card (with terminals)	Input/output card
*	HD-FXLIPS00	Thermocouple mV input card (with terminals)	
*	HD-FXRTDPS0	RTD input card (Air conditioning specifications: - 20 to 80°C , with terminals)	
*	HD-FXRTDPS1	RTD input card (free range, with terminals)	
*	HD-FXPIPS00	Pulse input card (with terminals)	
*	HD-FXAOPS00	Analog output card (with terminals)	
*	HD-FXDIPS00	Digital input card (with terminals)	
*	HD-FXG7IS00	Digital input card (with terminal panel for connecting to the OMRON G7TC)	
*	HD-FXDOPS00	Digital output card (SS output, with terminals)	
*	HD-FXG7OS00	Digital output card (with terminal panel for connecting to the OMRON G7TC)	
*	HD-FXDYPS00	Digital output card (with relay terminals)	Necessary when using terminal panel for connecting to the OMRON G7TC
	HD-FXG7C10	G7TC connection cable : 1m	
	HD-FXG7C15	G7TC connection cable : 1.5m	
	HD-FXG7C20	G7TC connection cable : 2m	
	HD-FXG7C30	G7TC connection cable : 3m	
	HD-FXG7C50	G7TC connection cable : 5m	
*	HD-FXESTS00	EST smart terminal I/F card	Necessary when connecting the EST
	HD-FXSWRTCF	RTC_FLEX (software)	

* : For varnish finished products, a "C" is affixed to the end of the model number.

■ Functions of each part

Names of each part are shown in Figure 4.

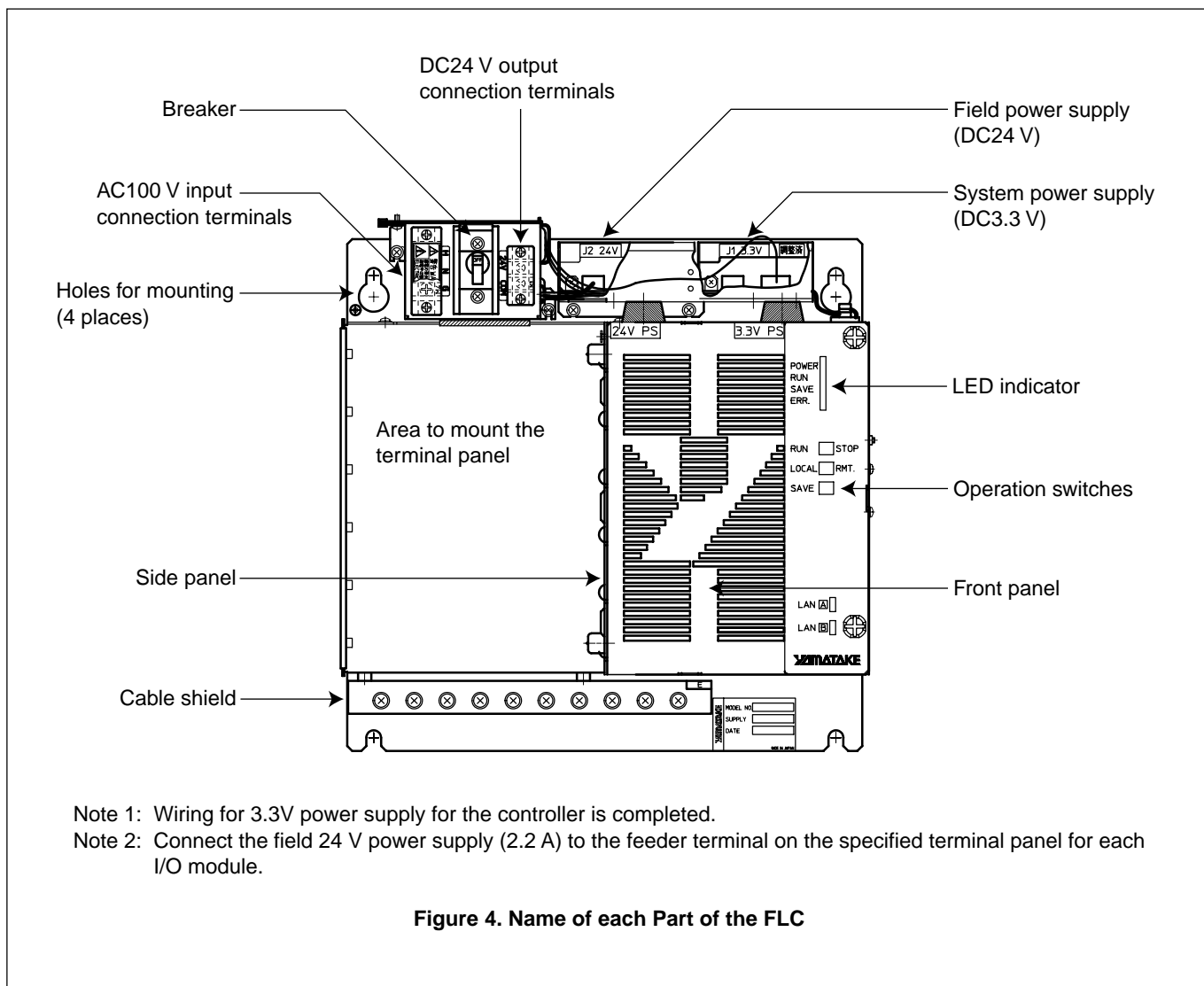

Functions of the LED indicator are as follows:

- POWER : Lights up when the power supply of the communication control unit is normal.
- RUN : Lights up while the control is being executed.
- SAVE : Lights up when the control database exists in the flash memory. Blinking during saving.
- ERR. : Blinking when any error occurs.

Functions of the operation switches are as follows:

- RUN/STOP : Starts/stops the control and brings the system into idling status.
- LOCAL/RMT. : Switches to the LOCAL side when operating control start and stop with the above-mentioned switch; switches to the RMT. side when operating through the RTC.
- SAVE : Executes saving. Move the switch to the left and continue to hold it there until the SAVE LED starts to blink. When the switch is released, it returns to the right.

3. Control Functions

Control functions are classified into the following control points:

■ Regulatory PV Point (RegPV)

Standard I/O processing functions, like industrial unit conversion and alarm, are directly carried out by using I/O monitoring. The regulatory PV point performs the process variable (PV) calculation and compensation functions. Algorithms such as flow rate compensation, integration and variable dead time compensation implement PV processing. It is available to provide more enhanced configuration such as alarm suppression, signal filtering, etc. Signal filtering, algorithm and calculation formula options.

For available algorithm and other supported functions, see Table 8.

Table 8. Regulatory PV Points

Available algorithm	Support function
Data acquisition	PV source selection (Automatic, manual, substitution)
Flow rate compensation	
Middle of three	PV clamping
High/low/average selector	Engineering unit conversion and PV extension range check (Sensor failure)
Summer	
Totalizer	PV status
Variable dead time	PV filtering
Lead/lag compensation	PV alarming
General linearization	- Bad PV (Sensor failure)
Calculator algorithm	- PVHI, PVLO - PVHIHI, PVLOLO - PV rate of change alarm

■ Regulatory Control Point (Reg Ctl)

Regulatory control points are used to carry out the control functions of FLC. Configuration of the algorithms listed in Table 9 carries out the regulatory control point functions. Each algorithm contains configurable options and performs complicated control by a simple menu selection. Functions provided as standard functions include initialization and windup protection. The set point ramping (by operator entry of target values and lamp time) is also configurable.

Table 9. Regulatory Control Points

Available algorithm	Support function
PID	Mode/mode attribute
PID with feed forward	Red tag
PID with external feedback	Initialization
Position proportional	Anti-reset windup
Ratio control	External mode switching
Ramp/soak	Safety shutdown
Auto/manual station	Output limit
Incremental summer	PV source selection
Switch	PV alarming
Override selector	- Bad PV (Sensor failure) - PVHI, PVLO - PVHIHI, PVLOLO - PV rate of change alarm

■ Digital Composite Point (Dig Comp)

Digital composite points are multi input and multi output points that provides interface to discrete equipment, like the motors, pumps and solenoid valves. These points provide interlock processing functions as standard functions. These points can also display interlock states on the screen of an Harmonas-DEO supervisory station. The displayed states have information effective for tracking the cause of interlock. The " / local / hand / off / auto / " switches generally used for motor driving equipment can also be handled. Figure 5 shows the major parameters related to this type of control point.

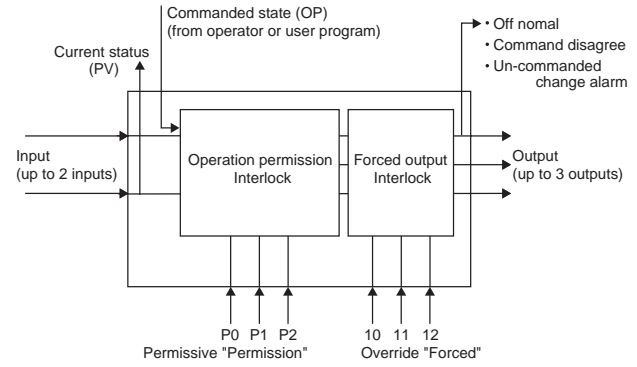

Figure 5. Structure of Digital Composite Points

■ Logic Point (Logic)

Logic points are used together with digital composite points to provide interlock logic functions.

A logic point has a processing equivalent of up to two pages of relay ladder logic.

A logic point consists of logic blocks, flags, numeric variables, input connection and output connection. There are three types of combinations in configuration of inputs, outputs, and logic block of a logic points. (See Table 10)

In addition to the logic block functions, logic points are available as data transfer points. This reads data from input connections and makes an output connection of this data, so that the data can be transferred to a parameter of other defined databases.

Table 10. Maximum Configuration Example of Logic Points

Type \ Configuration	Input	Output	Logic block
Option 1	12	4	16
Option 2	12	8	8
Option 3	12	12	0

Note: Each logic point provides six status flags, six user flags and four numeric value variables.

Table 11. Logic Block Algorithm

Logic	AND
	OR
	NOT
	NAND
	NOR
	XOR
	QUALIFIED-OR 2 (2-input majority decision) QUALIFIED-OR3 (3-input majority decision)
Comparison	EQ (= with dead band)
	NE (\neq with dead band)
	GT (> with dead band)
	LT (< with dead band) LE (\leq with dead hand)
Delay	DELAY
	ON DELAY
	OFF DELAY
Pulse	FIXPLS (fixed length pulse)
	MAXPLS (maximum time limit pulse)
	MINPLS (minimum time limit pulse)
Watch dog timer	WATCHDOG
Flip flop	FLIPFLOP
Input error check	CHECKBAD
Switch	SWITCH
State change detection	CHDETECT

Note:AND, OR, NAND and NOR gates accept three inputs per block. Options are available to inverse inputs.

■ Function Block Point (FB)

Function block point consists of 91 types of function blocks (see Table 12). Up to 2048 function blocks are available per point. Conforming to a block notation system called SAMA (Scientific

Apparatus Makers Association), these function blocks can construct control functions by a logic diagram system.

Table 12. Function Block Algorithm

Arithmetic operation (8 types)	ADD (addition) MOD (modulo)	SUB (subtraction) EXPT (exponent xy)	MUL (multiplication) SUM (4-point addition)	DIV (division) DADD (digital addition)
Single number value variable (13 types)	ABS (absolute value) LOG (customary logarithm) TAN (tangent) PSQRT (percent square root)	SQR (square) EXP (exponent ex) ATAN (arctangent)	SQRT (square root) SIN (sine) TRUNC (truncation)	LN (logarithm natural) COS (cosine) ROUND (rounding)
Selection (9 types)	MAX (maximum value) HSE (high selector) SW (switch)	MIN (minimum value) LSE (low selector) SFT (softening switch)	AVG (average value) MID3 (middle of three) ALSW (alternate switch)	
Detection (12 types)	HLM (high limiter) LMS (low monitor) BADCHK (badness check)	LLM (low limiter) DRM (rate-of-change monitor) INFCHK (infinity check)	DRL (rate-of-change limiter) DMS (deviation monitor) QLTCHK (change check 1)	HMS (high monitor) NUMCHK (normality check) CHGCHK (change check 2)
Conversion (4 types)	PTE (EU value conversion)	ETP (% conversion)	FUNC (function conversion)	CONV (data type conversion)
Logical operation (11 types)	AND (logical product) NOR (inverted logical sum) RS (reset)	OR (logical sum) XOR (exclusive logical sum) ORIN4 (4-input logical sum)	NOT (inversion) QOR2 (2-input majority decision) ANDIN4 (4-input logical product)	NAND (inverted logical product) SR (set)
Comparison (6 types)	EQ (= with dead band) GE (\geq with dead band)	NE (\neq with dead band) LT (< with dead band)	GT (> with dead band) LE (\leq dead band)	
Pulse (3 types)	FIXPLS (fixed length pulse)	MAXPLS (maximum time limit pulse)	MINPLS (minimum time limit pulse)	
Timer (5 types)	CYCPLS (timer) OFFDLY (off delay)	WDT (watch dog timer)	DELAY (delay)	ONDLY (on delay)
Counter (4 types)	UCNT (up counter)	DCNT (down counter)	AAV (analog totalizer)	PAV (pulse totalizer)
Control operation (8 types)	PID (PID operation) LDLG (leading/delay)	PRO (proportion) DED (waste time)	INT (integration) TF (filtering time)	DIF (differentiation) DLTPV (speed type PV)
Others (7 types)	RMP (Ramp) SG (single)	MAV (moving average) FL (flag)	ANMA (analog memory) TIMFL (one shot FL)	GW (gate way) REDTAG

■ Process Module Data Point (Proc Mod)

Process control often requires flexible control programs that are also available for continuous process, batch or hybrid applications. Process module data point is a user generated program (CL program) written in special-purpose control language. This language provides powerful sequence control and calculation functions.

CL programs can access analog input and output, digital input and output, logic block status, alarm status, failure status, numeric value variables, and flags.

Process module data points provide phase, step and statement structures suitable for implementing batch process control functions. They can also activate a sequence for hold, shutdown, or emergency shutdown by means of the powerful function of the multilevel error processing.

■ Flag Point

Flag points indicate two states, such as on and off, and accepts entries of Boolean algebra values. Flag points can be changed by operators and user programs. Per FLC, 8192 flags are prepared, and 3000 flags out of 8192 are usable for user applications, others are reserved for system use. Of these 3000 flags, the first 512 flags support off-normal alarms (e.g. generates alarm at status on).

■ Numeric Point

Numeric points are numeric variables that literally save real values and are effective for batch (recipe) operations. Per FLC, 8192 numeric variable points are prepared and 3000 numeric variables are usable for users applications, others are reserved for system use. Like flag points, numeric value variable points are not included in the point processing schedule.

■ Timer Point

Timer points are effective for operators and user programs to supervise process events. Timer points are processed once every second. Per FLC, 32 timer points are prepared.

4. Alarm Functions

FLC supports alarm functions. If alarms occur, these alarms are notified onto an Harmonas-DEO supervisory station via various types of screens. Alarms are generally classified into PV alarms and digital alarms.

■ PV Alarm

For process variables, configurable PV alarms are as follows. Methods are available for setting alarms in I/O points or in control points. In general, if a control point uses an I/O point, an alarm is set in a control point. Otherwise, it is set in an I/O point.

- High
- High high
- Low
- Low low
- Rate-of-change positive
- Rate-of-change negative

A dead band can be set in all PV alarms mentioned above.

■ Digital Alarm

Digital alarms are divided into the following three types:

- Off-normal alarm
- Uncommanded change alarm
- Command disagree alarm

Off-normal alarms are simply generated when the status is on or off. Both uncommanded change alarms and command disagree alarms are set within digital composite points and detect a disagreement between input and output. A command disagree alarm detects a disagreement between input and output just after an output change, while an uncommanded change alarm detects a disagreement between input and output when no output change is made. Both alarms can set dead band time.

■ Alarm Priority

Alarm priority can be configured for individual alarm types for each point. Selectable alarm priorities can be divided into the following five types:

- Emergency
- High
- Low
- Journal only
- Only journal printer output (not used when the EST is connected)
- Journal recording + printer output (not used when the EST is connected)
- None (no action)

■ Contact Cutout

The contact cutout function allows a program to temporarily stop an alarm for each point having alarm functions. The "CONTCUT" parameter, prepared for the points having alarm functions, can be set to on to put the points in the alarm stop status.

5. Processing Performances

Combining regulatory control loops, logic functions, sequence and I/O processes, FLC can configure control functions according to applications. The configuration needs to take into account restrictions on the maximum number of points per FLC, the processing unit (PU value), which is a unit of processing capability, and the memory unit (MU value), which is a permitted memory unit of CL program size.

■ Maximum Number of Points

The maximum number of points settable per FLC is as follows.

Table 13. Maximum Number of Points (per FLC)

Point type	Maximum number of points
Regulatory control	32
Regulatory PV	32
Process module	128
Logic	64
Digital composite	256
Function block	128
Numeric value variable (NN)	8,192(Note 1) + 80 × (number of sequences used)
Flag variable (FL)	8,192(Note 2) + 128 × (number of sequences used)
Timer variable (TM)	32
I/O point	(Number of points per I/O card) × 23

Note 1: 3,000 points are for use by the user, and the rest is reserved the system.

Note 2: 3,000 points (including 512 for alarm) are for use by the user and the rest is reserved for the system.

■ Maximum Number of Blocks

The following restrictions apply to the function blocks, components of function block points.

Table 14. Maximum Number of Function Blocks

Function block point Per point	2048 blocks
Per FLC	2048 blocks

■ Processing Unit (PU Value)

This unit represents the processing capability of FLC, determined based on the point types, control cycles, etc.

PU values differ depending on point types and control cycles. The following table lists the maximum PU values per FLC and PU values at points.

Table 15. Maximum PU Value (Per FLC)

Point Type	PU value
Total of control points and function blocks and of I/O points	700

Table 16. List of PU Values of I/O Points

Device	PU Value				
	I/O Monitoring Cycle				
	1sec	0.5sec	0.2sec	0.1sec	
Main unit	2.0	-			
Expansion unit (for each unit)	4.0	-			
Digital input (DI) (for each card)	-	0.7	1.1	2.3	4.3
Digital output (DO) (for each card)	-	0.2	0.4	1.0	2.0
Analog input (AI) (for each card)	-	1.5	2.2	4.3	7.8
Thermocouple mV input (for each card)	-	0.9	-	-	-
RTD input (Room temperature) (for each card)	-	1.5	2.2	4.3	7.8
RTD input (Free range) (for each card)	-	0.9	-	-	-
Analog output (AO) (for each card)	-	0.3	0.6	1.5	3.0
Pulse input (PI) (for each card)	-	1.0	1.4	2.6	4.6

Note: In AI, it is assumed that two alarms (occurrence or restoration) at a time occur every second in the 4 slots.

In DI, it is assumed that one off-normal alarm at a time occurs every second in the 8 slots.

Table 17. List of PU Values (Control Cycle = 1 sec)

Control Point Name	1sec PU Value
RegPV	0.8
RegCtl	1.1
Logic	0.7
DigComp	0.1
ProcMod (short)	1.0
ProcMod (long)	2.0

Function Block	1sec, PU Value	Function Block	1sec, PU Value	Function Block	1sec, PU Value
ADD	0.027	LLM	0.018	LE	0.027
SUB	0.027	DRL	0.044	FIXPLS	0.027
MUL	0.027	HMS	0.018	MAXPLS	0.027
DIV	0.027	LMS	0.018	MINPLS	0.027
MOD	0.022	DRM	0.044	CYCPLS	0.031
EXPT	0.027	DMS	0.027	WDT	0.027
SUM	0.031	NUMCHK	0.018	DELAY	0.018
DADD	0.031	BADCHK	0.018	ONDLY	0.031
ABS	0.018	INFCHK	0.018	OFFDLY	0.031
SQR	0.018	QLTCHK	0.018	UCNT	0.022
SQRT	0.018	CHGCHK	0.027	DCNT	0.022
LN	0.027	PTE	0.022	AAV	0.031
LOG	0.027	ETP	0.022	PAV	0.031
EXP	0.027	FUNC	0.031	PID	0.083
SIN	0.027	CONV	0.035	PRO	0.027
COS	0.027	AND	0.022	INT	0.053
TAN	0.027	OR	0.022	DIF	0.070
ATAN	0.027	NOT	0.022	LDLG	0.044
TRUNC	0.027	NAND	0.022	DED	0.040
ROUND	0.027	NOR	0.022	TF	0.053
PSQRT	0.018	XOR	0.022	DLTPV	0.027
MAX	0.031	QOR2	0.027	RMP	0.035
MIN	0.031	SR	0.022	MAV	0.048
AVG	0.031	RS	0.022	ANMA	0.031
HSE	0.027	ORIN4	0.031	GW	0.022
LSE	0.027	ADDIN4	0.031	SG	0.018
MID3	0.031	EQ	0.027	FL	0.018
SW	0.027	NE	0.027	TIMFL	0.031
SFT	0.044	GT	0.027	REDTAG	0.018
ALSW	0.022	GE	0.027		
HLM	0.018	LT	0.027		

■ Memory Unit (MU Value)

Memory unit value is a unit value indication that helps user in using memory of FLC, this determines the total size of CL programs. Memory unit values are used to store CL programs themselves. For MU value calculation, a total numbers of statements of CL programs are divided by three statements in average. An MU value is then found by the quantity of statements. Each division is called a CL block, with 1CL block = 1 MU.

The maximum MU value per FLC is 6080.

Different from PU values, MU values are not affected by control cycles or the number of I/O points.

■ Control Cycle

Control cycles are selectable per FLC from among 1 sec, 500 msec, 200 msec and 100 msec (for combinations, see Table 18). In addition to the control cycles, some of the data points can be processed at high speed (100 ms) by means of fast scan function.

Table 18. Combination of Control Cycles

SCANRATE Parameter	Point Type			FB
	RegcTl, RegPV	Logic, DigComp	PromMod	
Reg1 Log1	1sec	1sec	1sec	Selection of the following control cycles per point • 1sec • 500msec • 200msec • 100msec
Reg1 Log2	1sec	500msec	1sec	
Reg1 Log5	1sec	200msec	1sec	
Reg1 Log10	1sec	100msec	1sec	
Reg2 Log2	500msec	500msec	1sec	
Reg2 Log5	500msec	200msec	1sec	
Reg2 Log10	500msec	100msec	1sec	
Reg5 Log5	200msec	200msec	1sec	
Reg5 Log10	200msec	100msec	1sec	
Reg10 Log10	100msec	100msec	1sec	
Fast scan	100msec	100msec	100msec	

6. Smart Debug

The smart debug function can check operations of various control functions and I/O processing functions provided by FLC without using I/O cards.

This function can be carried out per FLC. After the transition to the debug mode, the function neither receives inputs from I/O cards nor transmits outputs to I/O cards, except for performing controlling operations within FLC and I/O processing operation. Engineers can set any values on FLC as virtual process data, making the debugging of CL programs, etc., easy. Engineers can operate and supervise the status of the debug mode on the EST or the Harmonas-DEO supervisory station.

7. Software Simulation

The software simulation function (option) allows standalone PCs to virtually runs functions of FLC. Using this function enables creating and verifying (debugging) applications in an environment without actual machines. One PC can perform those operations for more than one FLC.

8. Restart

The FLC restarts operation based on data from the flash memory on the control card (CTC) at a time of normal restart. It is designed so that, at restart, the necessary startup operations become minimal, while the status of the process is maintained. The control loop performing output to the field is switched into the manual mode, and the sequence can be selected from among automatic start from the beginning, stop at the first step, or stop at the last execution position.

Data save to the flash memory can be manually performed with switches on the front panel of the controller or on the EST.

9. Connection of the expansion base units

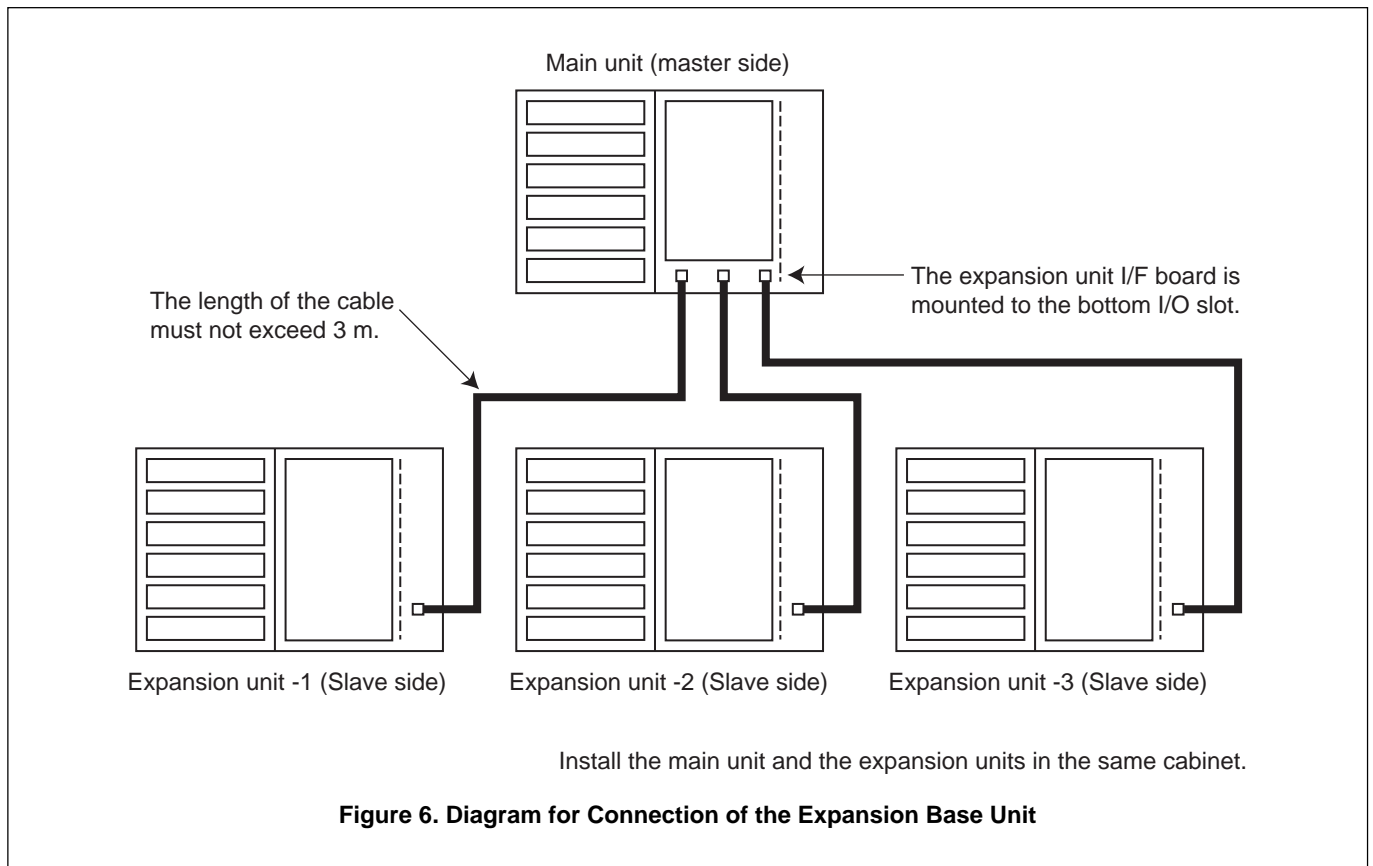

10. Outer Dimensional Drawing

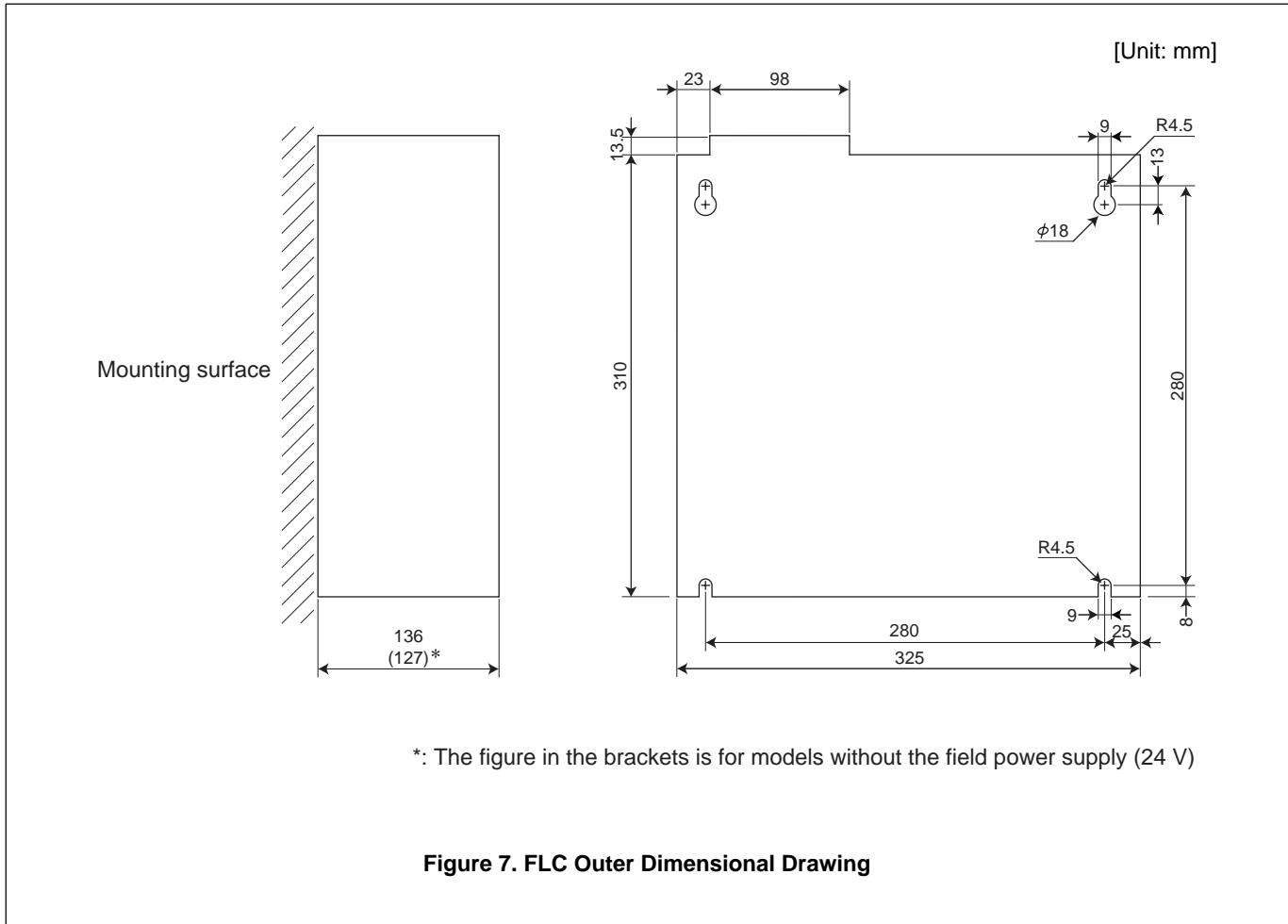

- Windows 2000, Windows, MS are trademarks of Microsoft Corporation of USA and other countries.
- Ethernet is a trademark of the XEROX Corporation of USA.
- Pentium is a trademark of Intel Corporation of USA.
- Other product names, model nos., company names are trademarks of each company.

Specifications are subject to change without notice.

Yamatake Corporation Advanced Automation Company

1-1-32 New Stage Yokohama, Shin-urashima-cho,
Kanagawa-ku, Yokohama, Kanagawa-ken 221-0031, Japan
Tel : +81-45-461-8800

YAMATAKE

Savemation

Saving through Automation

<http://www.yamatake.com/>

0406-Y/Y