

# TDC 3000 SSC II Fixed Program Controller Model KAS 110/210

## Introduction

The TDC 3000 Single Strategy Controller II (SSC II) Fixed Program Controller is a high-performance microprocessor-based digital controller. Auxiliary functions include square-root extraction, approximation by linearization table and alarm processing. These functions can be preselected with the Handy Communicator, or Data Setter on the side of the instrument which eliminates the need for complex programming procedures.

## Features

- A microprocessor is provided for each loop, maintaining independence of each control loop.
- Control loops can be expanded or modified in the unit of one loop.
- Cascade control can be performed with a single unit of controller.
- Control mode transfer can be done balanceless and bumpless.

## Operation

- Simultaneous bar graph (color LCD) and digital value displays.
- Parameter/reference display changes easily made on the side of the instrument.

## Engineering support tool

- Configuration can be made by the SSC II itself through the Data Setter on the side of the instrument.
- Easy configuration through interaction with personal computer.
- Configuration data changes in the field done with dedicated SSC II Handy Communicator.

## Standards met

- Panel dimensions comply with IEC regulations.

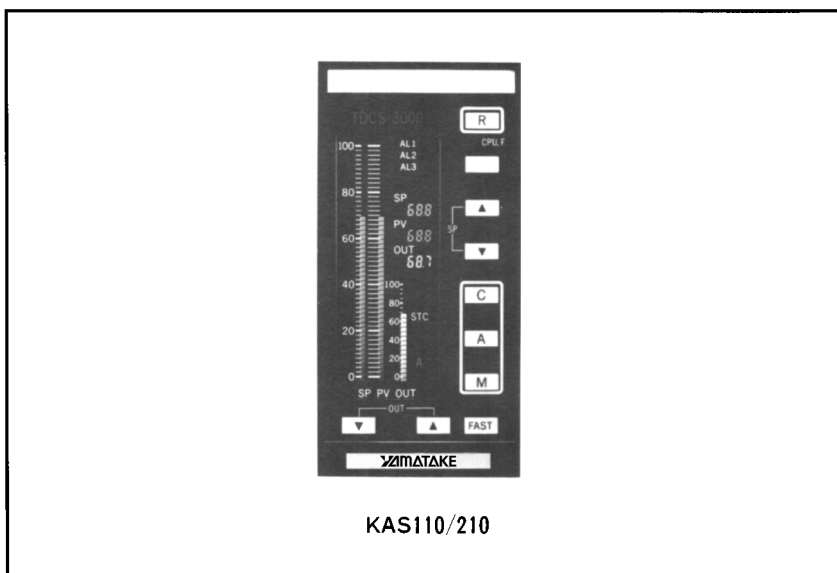

## Engineering configuration diagram

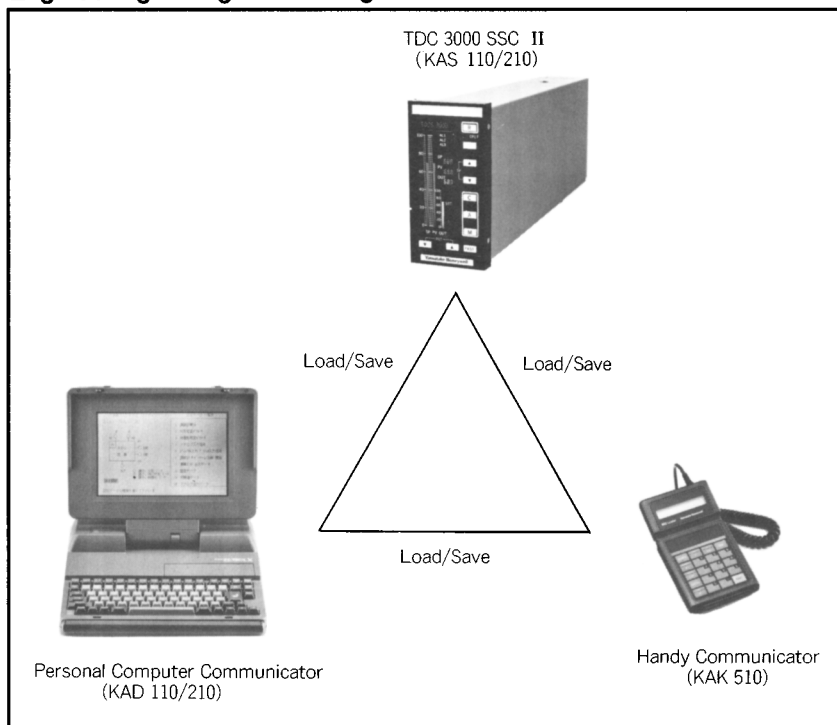

## Functional structure

- Regular PID control
- PID control with derivative-precedented on measured value
- PID control with differential gap
- PID control with ratio setting
- Cascade control
- External reset feedback

Legend :

SQR ...Square-root extraction

TBL .....Characterization table

DF .....Digital filtering

LLM ...Low limit

HLM ...High limit

MAN ...Manual output

PPAR ..Variable parameter

PPAR1 : Output lo-limit value

PPAR2 : Output hi-limit value

PPAR3 : AI1  $\sqrt{\quad}$  , dropout value

PPAR4 : AI2  $\sqrt{\quad}$  , dropout value

## Standard processing functions

- Square-root extraction
- Input linearization (2 tables available, 11 segments)
- Digital filtering
- Alarm (PV and deviation)
- Output limiting
- Automatic balanced mode transfer

## Input processing functions

The single function controller provides the two points of analog input signals with the following input processing

- Approximation by linearization table
- Square-root extraction
- Digital filtering
- Input alarm detection

## Construction of PID arithmetic

Units for PID arithmetic unit of each type of controllers, either one of the following two types of control actions can be selected.

Legend :

RSP.....Remote SP

LSP .....Local SP

HMS ...High monitor

LMS ...Low monitor

DEV.MS ..Deviation monitor

GAP.....Gap

DRL.....Deviation rate limiter

PPAR ..Variable parameter

PPAR5 : PID1 Monitor Hysteresis width

PPAR6 : PID2 Monitor Hysteresis width

## Functional block diagram

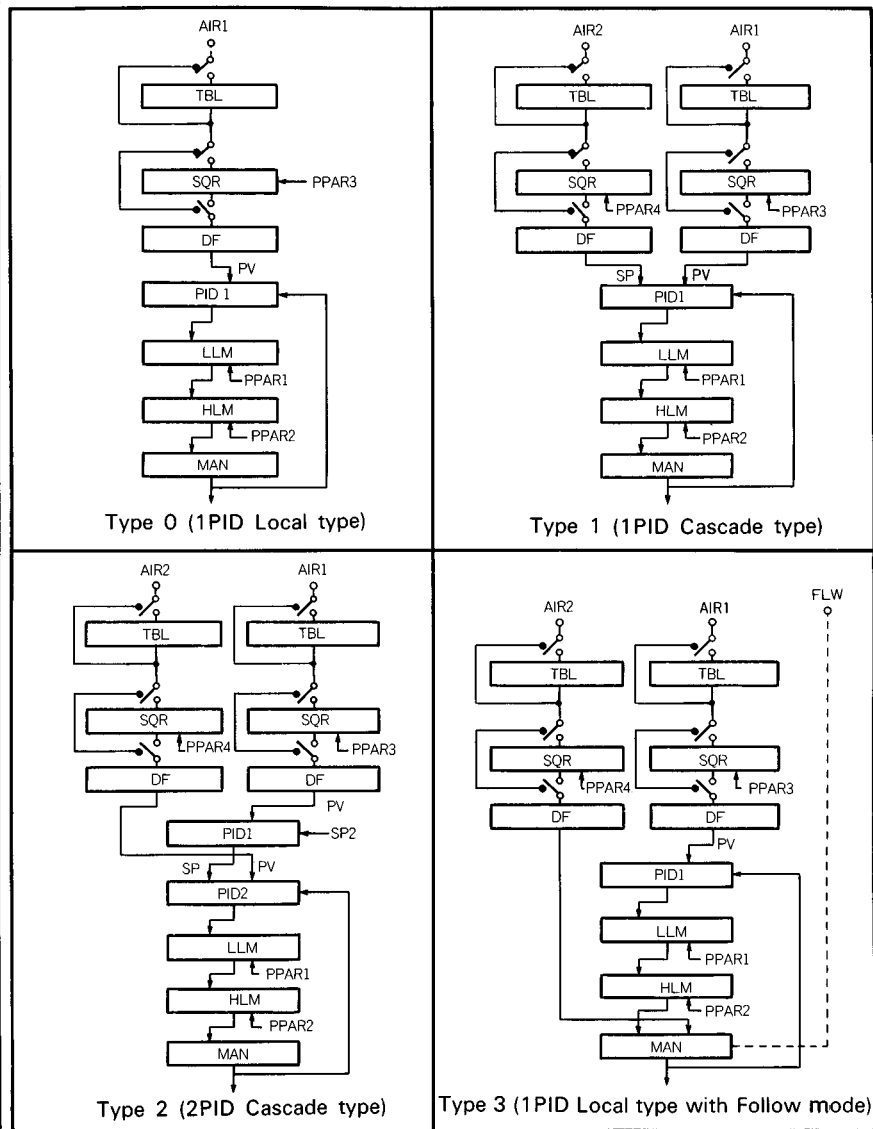

### (1) Regular PID control

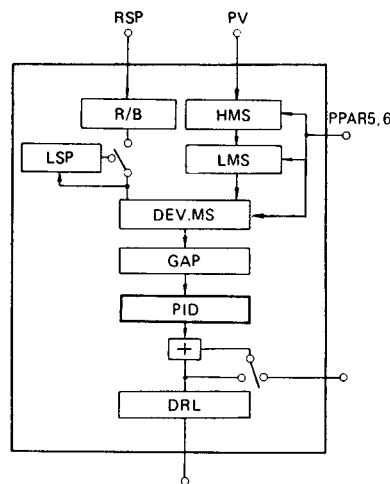

### (2) Derivative-precidedented PID control

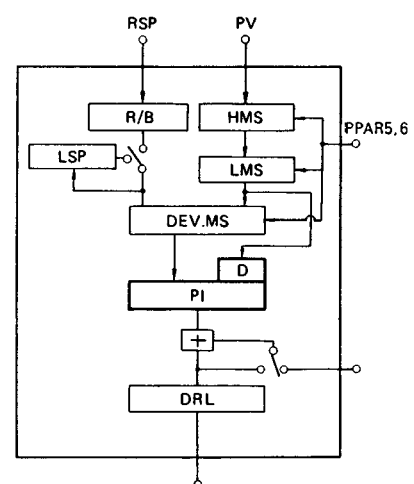

## Self-tuning function

The self-tuning function is based on Yamatake-Honeywell's unique "Advanced Loop Tuning" method. This technique is safe since tuning is continuously performed with a closed loop, which means there is no process instability.

- Automatic tuning by monitoring the process.
- Tuning as requested by the operator.
- Selectable between lo-gain control and hi-gain control.

## Advanced loop tuning block diagram

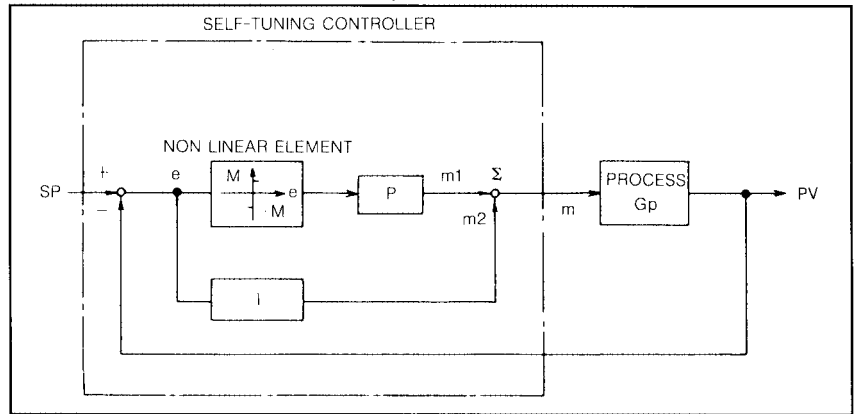

## Standard specifications

Item		Description	
Input Section	Analog Input	No. of inputs Input voltage Input impedance Receiving system Allowable input overvoltage	
	Digital Input	No. of inputs Input voltage Input bias current Allowable input overvoltage	
Output Section	Analog Output	Voltage	No. of outputs Output voltage Output impedance Output system
		Current	No. of outputs Output current Output impedance Allowable load Output system
	Digital Output	No. of outputs Output system Contact rating	
Indicator Section	Input	No. of indications Type of indicator	2 points (SP : green, PV : red) Simultaneous bar graph (% in color LCD) and digital value (engineering units) displays [bar graph: 53 segments, digital value: 7 segments (4 digits)] Digital indication : $\pm 0.15\% \text{ FS} \pm 1$ digit, bar graph resolution : 2%
		Indicating accuracy	
	Output	No. of indications Indication system	1 points (OUT: yellow) Simultaneous bar graph (% in color LCD) and digital value (engineering units) displays [bar graph: 23 segments, digital value: 7 segments (4 digits)] Digital indication: $\pm 0.25\% \text{ FS} \pm 1$ digit, bar graph resolution: 5%
		Indicating accuracy	
Alarm	No. of indications Indicating system	4 points (process alarm: 3, equipment alarm: 1) Color LCD and LED lamp	
Mode indication		Character indication by color LCD	

Operating Section	Operation control buttons		SP raise/lower buttons: 2 Output raise/lower buttons: 2 SP, output raise/lower acceleration button: 1 Mode switch buttons: 3 Reset button:1
	Data setter	Indicating method	LCD (16 digits)
		No. of setting buttons	24 (including display change button)
		Parameter tuning	PID Parameter Proportional band: 0.0 to 799.9% Reset time: 0.00 to 99.99min. Rate time: 0.00 to 99.99min. Reset upper/lower limit, Ratio, Bias, Dead band, Output deviation rate limit, Deviation alarm, PV alarm upper/lower limit, Analog input processing, Digital filtering, Engineering unit upper/lower limit Variable parameters % : -699.9 to 799.9% Time : 0.00 to 99.99min. Parameters for self-tuning Proportional band upper/lower limit, Reset time upper/lower limit, Rate time upper/lower limit, Rate time dropout, Decision rule, Giegler-Nichols/Chien
Auxiliary switches		Data entry enabling: 1 Start-up method switching: 1 Direct/reverse selectors: 2 Higher-order writing enabling: 1 Communication enabling: 1 Calibration switch: 1 Communicator switch: 1	
General Specifications	Power supply		24V dc + 15%, - 10%
	Power consumption		400mA dc maximum (24V dc, without option)
	Signal line connection		Instrument rear-panel terminal connection, Connecting line diameter: 1.25mm <sup>2</sup> maximum
	Power interruption/failure		16V dc or over, within 200 msec. (with STX type power supply) Data holding at power interruption • User program: Backup by EEPROM • Control data (SP OUT mode): RAM backup by super capacitor (72 hours) Power failure reset function: • HOT start (Operation resumes from prefailure status) • COLD start (Operation starts from preset value)
	Ambient temperature Ambient humidity		0 to 50°C 10 to 90% RH
	Installation Mounting angle		Panel flush mount, indoor installation Horizontal (Instrument back can be slanted 60° maximum from horizontal position.)
	Finish		Case: Dark beige Bezel: Black
	Weight		3.0kg (without standby manual unit)

### Optional specifications

Item	Description
① Standby manual unit (Preset type/follow-up type)	No. of indications: 1 point (with OUT/PV switch: A-type, preset B-type; without indication, follow-up B-type; is output only.) Indicating system: Moving coil type (A-type) LED bar graph type (follow-up type-B only) Indicating accuracy: ±5% FS Power supply: 24V dc Output impedance: 250kΩ Allowable load: Preset type; 500Ω Follow-up type; 600Ω Power consumption: Preset type: 60mA dc maximum (24V dc) Follow-up type: 120mA dc maximum (24V dc)
② Communication interface	S-link communication: 48k bits/sec. Transmission system: Complies with HDLC Transmission distance: 200m total Host: SSC Port, LCI

**Model number table**

Basic Model No.	Selections	Options			Description
	I	I	II	III	
KAS110					Fixed-program controller (A/M, SP operation available)
KAS210					Fixed-program controller (C/A/M, SP operation available)
	-0				Main power supply: 24V dc
		-0			Without communication interface
		-1			With communication interface
			0		Without self-tuning function
			1		With self-tuning function
				0	Without standby manual unit
				1	With standby manual unit (preset type A)
				2	With standby manual unit (follow-up type A)
				3	With standby manual unit (preset type B)
				4	With standby manual unit (follow-up Type B)

## Connection

1	2	23	24
3	4	25	26
5	6	27	28
7	8	29	30
9	10	31	32
11	12	33	34
13	14	35	36
15	16	37	38
17	18	39	40
19	20	41	42
21	22	43	44

No.	Symbol	Contents	No.	Symbol	Contents
1	+24V	Instrument main power ⊕	23	AIR1+	1-5V dc input ⊕
2	SM+24V	Standby manual power ⊕	24	AIR1-	1-5V dc input ⊖
3	AOI+	4-20mA dc output ⊕	25	AIR2+	1-5V dc input ⊕
4	AOI-	4-20mA dc output ⊖	26	AIR2-	1-5V dc input ⊖
5	AOV+	1-5V dc output ⊕	27	—	—
6	AOV-	1-5V dc output ⊖	28	—	—
7	—	—	29	—	—
8	—	—	30	—	—
9	—	—	31	—	—
10	—	—	32	—	—
11	OV	For Power, ALM, H/L/DEV and S common	33	—	—
12	OV		34	—	—
13	ALM·H	Alarm contact (H)	35	OV	For FLW, INT'K common
14	ALM·L	Alarm contact (L)	36	OV	
15	ALM·DEV	Alarm contact (DEV)	37	FLW	Follow mode select input
16	—	—	38	—	—
17	—	—	39	—	—
18	S	Standby mode output	40	—	—
19	SMPV+	PV ⊕ for standby unit	41	—	—
20	SMPV-	PV ⊖ for standby unit	42	INT'K	External interlock signal input
21	GND	Chassis ground	43	LINK+	S-link ⊕
22	GND		44	LINK-	S-link ⊖

## Dimensions

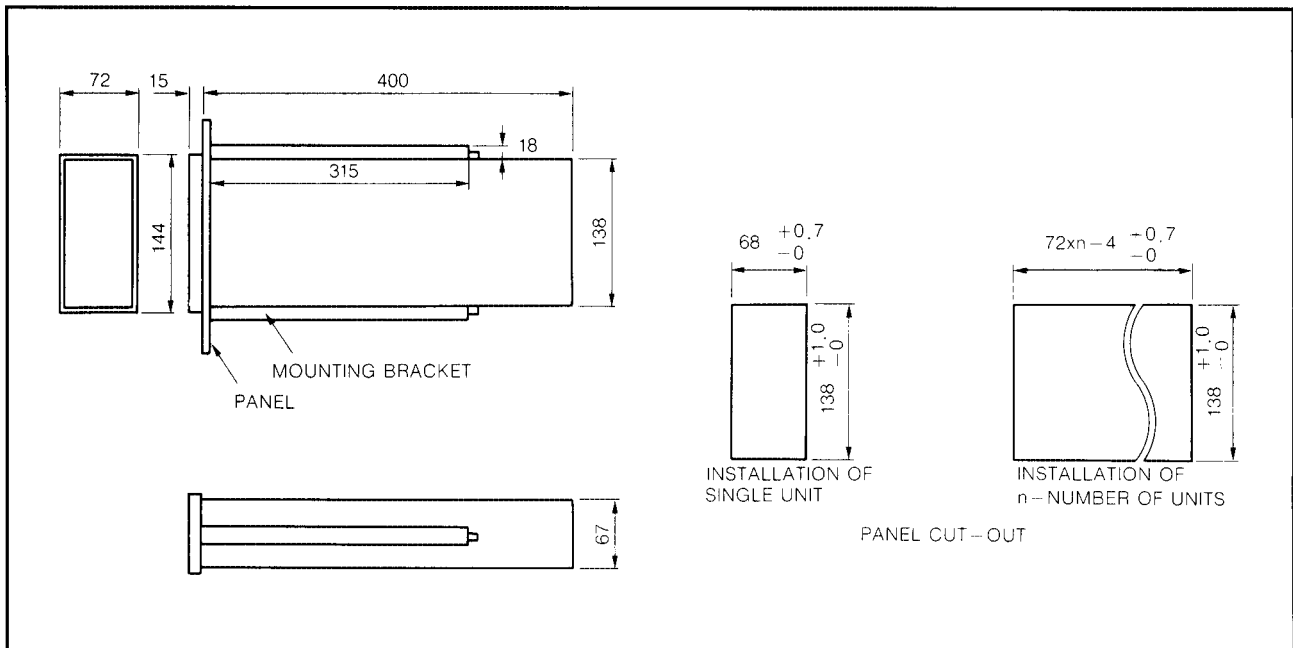

## Ordering Information

When ordering, please specify :

- 1) Model No.
- 2) Measuring range
- 3) Tag No.



Specifications are subject to change without notice.

**YAMATAKE**

## Yamatake Corporation

Totate International Building  
2-12-19 Shibuya  
Shibuya-ku Tokyo 150-8316  
Tel : 81-3-3486-2216  
Fax : 81-3-3486-2503

Yamatake-SIC Control Systems Co., Ltd.	: China	86-10-6510-2505
Shanghai Yamatake Jinshan Control Instruments Co., Ltd.	: China	86-21-6428-8661
Yamatake Korea Co., Ltd.	: Korea	82-2-785-0280~2
Yamatake Taiwan Co., Ltd.	: Taiwan	886-2-2501-1066
Yamatake (Thailand) Co., Ltd.	: Thailand	66-2-210-0900~7
Yamatake Philippines, Inc.	: Philippines	63-2-817-6452
PT. Yamatake Berca Indonesia	: Indonesia	62-21-230-5538
Yamatake Controls Singapore Pte. Ltd.	: Singapore	65-778-5966
Yamatake Automation (M) Sdn. Bhd	: Malaysia	60-3-706-5740
YCV Corporation	: U.S.A.	1-281-880-8188

## Yamatake Industrial Systems Co.,Ltd.

*This has been printed on recycled paper.*

**Savemation**

*Saving through Automation*

<http://www.yis.yamatake.co.jp/>

0301-Y/Y