

I/O card < Pulse Input >

Specification of PIM00/PIF00

	Item	Specification
High-Speed Pulse (Counter) Inputs	Module Type	<u>J-PIM00/PIF00</u>
	Points/Module	8
	Points/Controller	64 (maximum)
	Isolation	Optical isolation with photocoupler
	Common	8 points/common
	Input Circuits	Current source type
	Input Power Supply	
	• when FTB is used	Nominal: 24 Vdc Operable Range: 15 to 30 Vdc
	• when RTP is used	Nominal: 24 Vdc Operable Range: (15+0.015ℓ) to 30 Vdc ℓ ≤ 100 m (ℓ: I/O cable length)
	Input Signals	Contact signals or open collector signals ON: 13 Vdc or greater, or 3 mA or greater OFF: 5 Vdc or greater, or 1.2 mA or greater
	Pulse Rate	5 kHz maximum
	Input Filter Constants	A) 10 μs (up to 5 kHz) B) 10 ms (up to 20 Hz) Selectable for each input point
ON/OFF Time	A) ON: 0.1 ms or greater, OFF: 0.1 ms or greater (When filter A is used) B) ON: 25 ms or greater, OFF: 25 ms or greater (When filter B is used)	
Scan Period	0.5 sec.	

EC-Link Adaptor (ECLA)

When the EC-Link is mounted between the cabinets, it uses the EC-Link Adaptor (ECLA). The ECLA is directly mounted on the cabinet. TB1 and TB2 connect the external EC-Link and the terminator.

Field Termination

Input and output connection terminals to the field are designed to cope with a wide range of wiring requirements. The Front Terminal Block (FTB) termination type allows direct connection of field wiring to the front end of the I/O modules. The Remote Terminal Panel (RTP) allows connection between the terminal panel mounted in the cabinet or the relay terminal panel and the I/O modules via a dedicated cable (up to 100 m). The field signals can be connected to the terminal through the systempak signal converter.

It provides a total of 9 types of RTPs depending on the kinds of inputs and outputs: for digital input/output, digital output, analog input, analog output, pulse input and extended digital output. One type of FTB allows connection to a range of inputs and outputs. The remote terminal panel for analog output (for standby manual) provides the connector to connect the

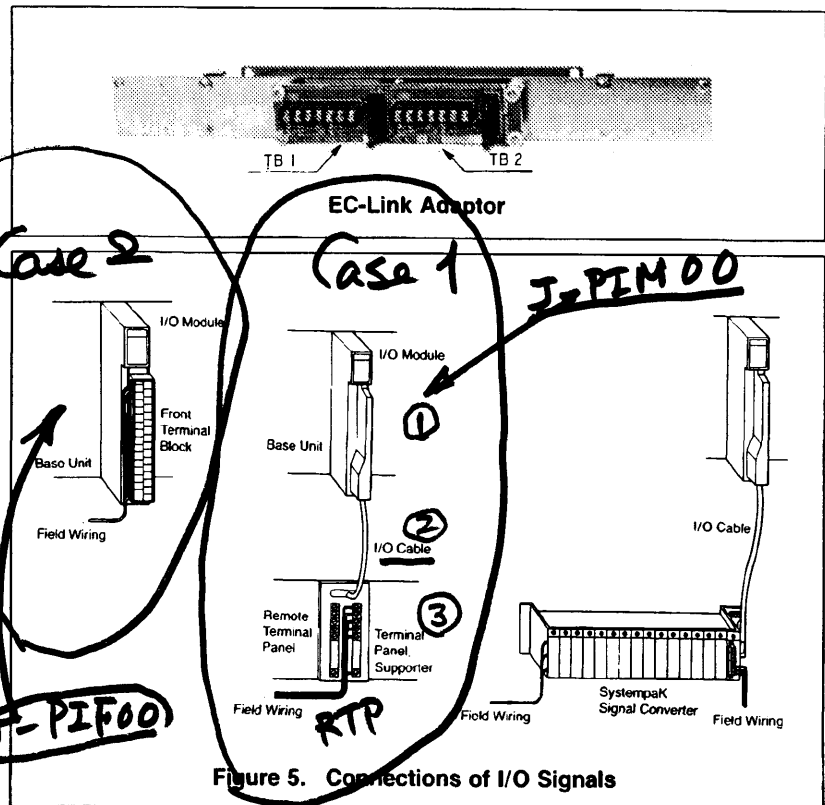

Figure 5. Connections of I/O Signals

standby manual unit. The RTP for analog input provides the transmitter power supply, current limiter circuit and current-voltage conversion resistor.

Table 4. Remote Terminal Panel

Name	Model No.	Available I/O module Combination	Description
Analog input RTP	J-RTP10	J-HAM10 J-HAM00 J-STM00	Transmitter power supply available (24 Vdc) With current limiter circuit 16 inputs, 4 to 20 mA or 1 to 5 V (Selectable for each input)
Analog output RTP	J-RTP20	J-AOM10	16 or 8 outputs can be used. 4 to 20 mA
	J-RTP30	J-AOM10	Standby manual unit can be connected in conjunction with the RTP20
Digital input RTP	J-RTP00	J-DIM00 J-DIM10	32 inputs, dry contact input
Digital output RTP	J-RTP00	J-DOM00 J-DOM10	16 outputs, open-collector output 32 outputs, open-collector output
	J-RTP40	J-DOM00	32 outputs, open-collector output (One J-RTP40 requires 2 modules of J-DOM00.)
	J-RTP80	J-DOM20	16 outputs, relay output (Relay is on the DO module (not on the RTP.))
Extended digital output RTP	J-ETP00	J-DOM00	16 outputs, relay output (Relay is on the RTP and open collector is corrected to a relay output.)
Pulse input RTP	J-ETP50	J-PIM00	8 inputs, dry contact input

Auxiliary terminal

In addition to the terminal for field input/output, this terminal provides devices which display external system status, initialize UAC backup by an external contact input, and judge power interruptions and failures.

The Base Unit Terminal (J-BTP00) provides the contact outputs to show the UAC backup state and UAC disable state and the contact inputs to initialize the UAC backup and restart after an interruption. The Power Down Monitor (J-PDM00) monitors the ac power supply and commands the restart procedure to the A-MC by comparing actual ac interruption time with the interruption definition time. Connection between the Power Down Monitor and the A-MC Base Unit is accomplished through the Base Unit Terminal.

Power Supply and Grounding Requirements

AC Power Requirements	Type: J-STX5I 1/6□ Voltage: ac 105/115/230 V ±15% Frequency: 50/60 Hz ±1 Hz
DC Power Requirements	Voltage: 22 to 30 V Ripple: 0.8 Vp-p Interruptions: <1 ms
Grounding Requirements	One grounding point for each of the following is required. <ul style="list-style-type: none"> • Protective ground (FG) Class 3 • System ground (SG) Class 1 or Special Class 3

< Case 1 >

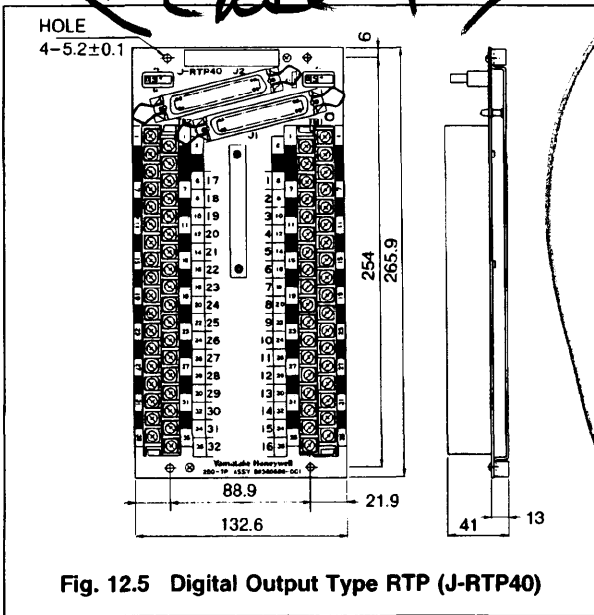

Fig. 12.5 Digital Output Type RTP (J-RTP40)

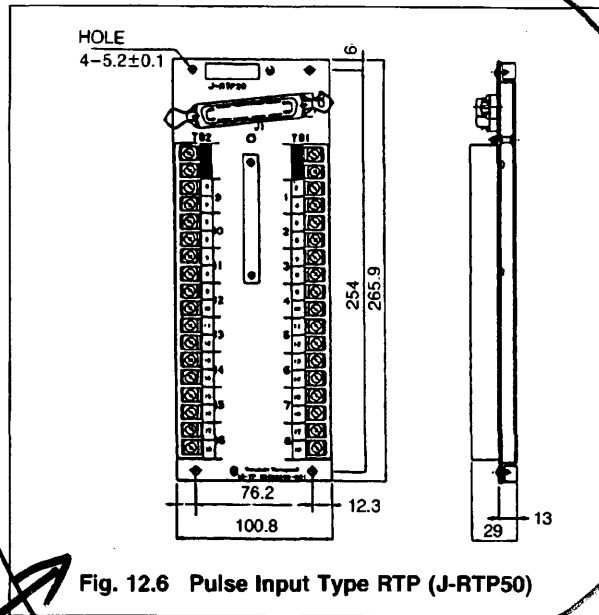

Fig. 12.6 Pulse Input Type RTP (J-RTP50)

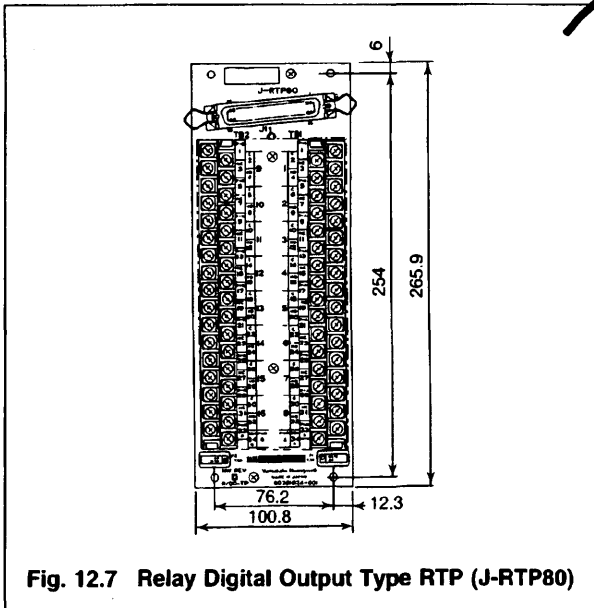

Fig. 12.7 Relay Digital Output Type RTP (J-RTP80)

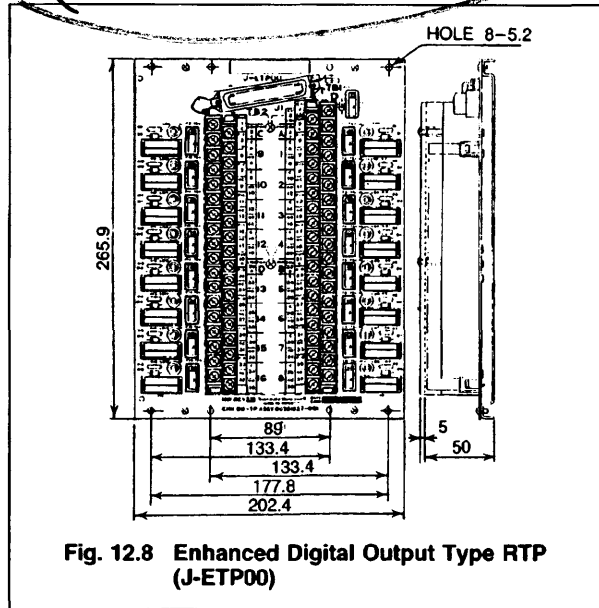

Fig. 12.8 Enhanced Digital Output Type RTP (J-ETP00)

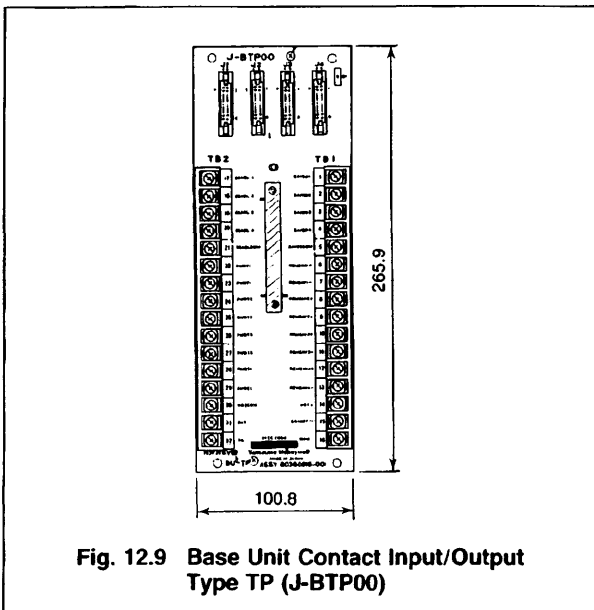

Fig. 12.9 Base Unit Contact Input/Output Type TP (J-BTP00)

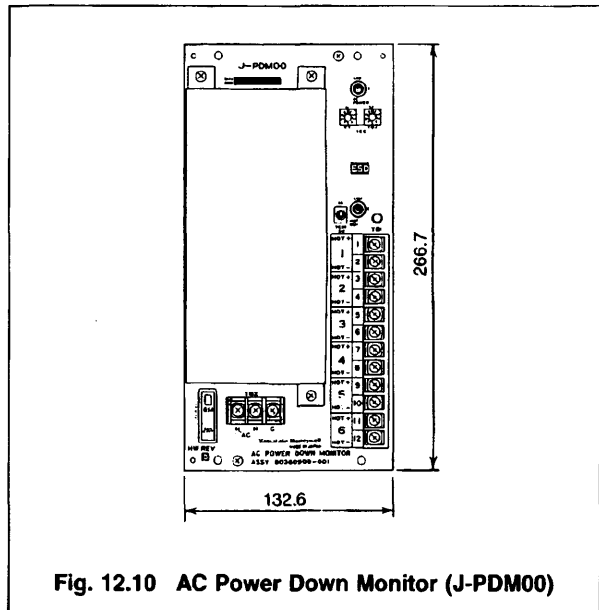

Fig. 12.10 AC Power Down Monitor (J-PDM00)

Figure 12. Dimensions of Remote Terminal Panels

< Case 1 > Use "RTP" for Pulse Input Card (PIM00)

(6) ~~パルス入力用~~ (J-RTP50)

パルス入力モジュール (J-PIM00) に対して使用します。入力はTB1に接続し、TB2は空端子となります。



図 7-28

TB1 の 1、2 番端子には、パルス入力モジュールの入力回路用 DC24V 電源を接続します。PIM00 システム電源と非絶縁で良い場合は、TB2 の 1、2 番端子 (PIP +、PIP-) を接続します。

< Case 1 >

PI cable PIN ^{Assigned} Numbers.

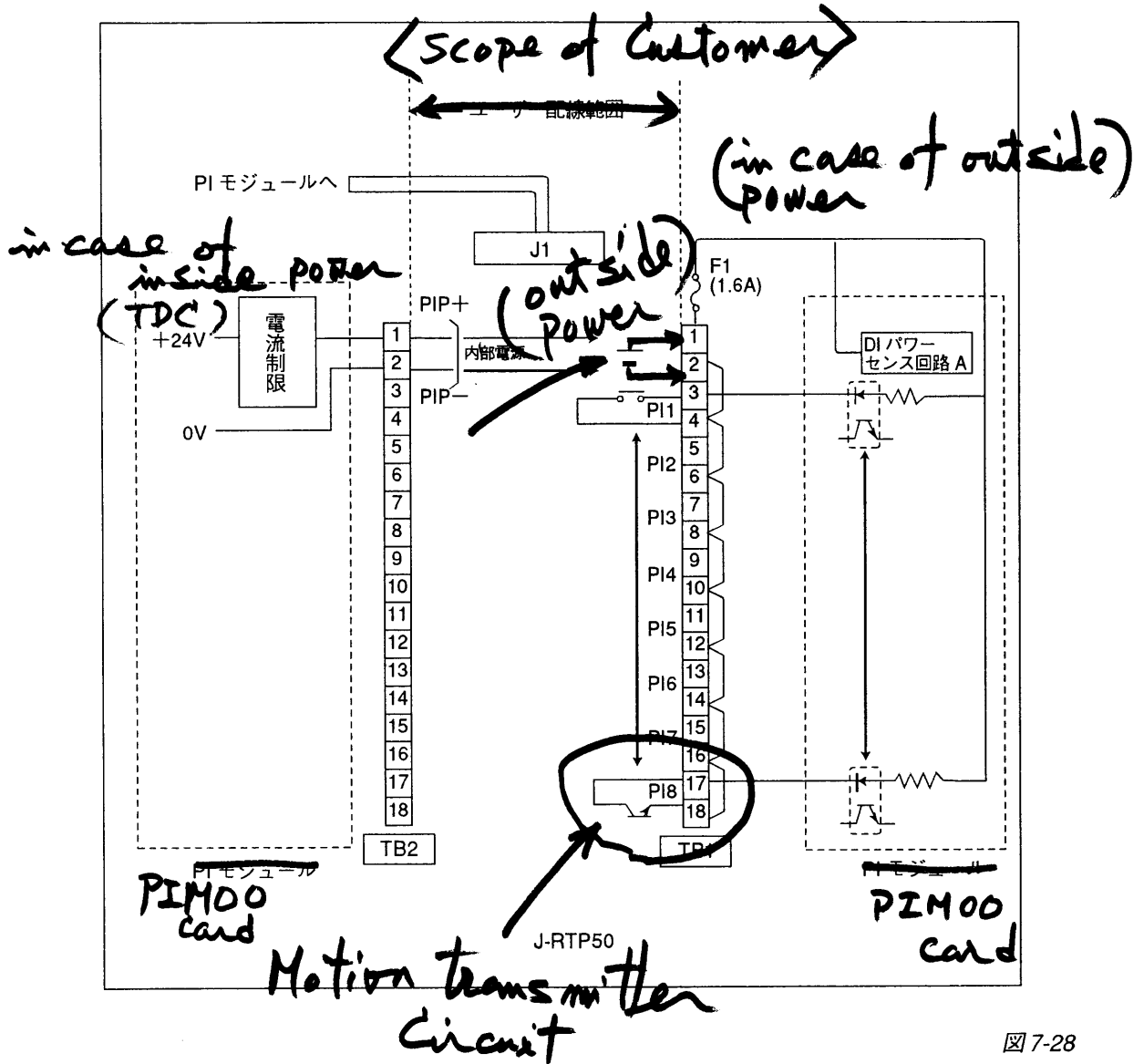
表 7-5 PI ケーブル・ピン番号表 (J-PIM00 使用時)

信号名	コネクタ・ピン番号	
	RTP用	汎用
EX24V	1	A
	36	AA
	38	y
	39	x
EXCOM	2	B
	34	CC
	35	BB
	37	z
1PI	+	3 C
	-	4 D
2PI	+	5 E
	-	6 F
3PI	+	7 J
	-	8 K
4PI	+	9 L
	-	10 M
5PI	+	27 MM
	-	26 NN
6PI	+	29 KK
	-	28 LL
7PI	+	31 HH
	-	30 JJ
8PI	+	33 DD
	-	32 EE
PIP+	41	u
	42	t
	43	s
	45	p
PIP-	40	v
	44	r
	46	n
	47	m
	11	N
	12	P
	13	R
	14	S
	15	U
	16	V
	17	W
	18	X
	19	Y
	20	Z
	21	a
22	b	
23	c	
24	d	
25	e	
LIC	48	l
LICC	49	k
	50	j

(outside power supply)
24 VDC (外部電源の場合)
PIP +, - (内部電源の場合)
24V~27V.
outside power

PI 4
PI 5 Motion transmitter

- 注1. PIPを使用した場合はアイソレーション機能はなくなります。
2. 外部電源の場合電源ヒューズが必要です。
3. 入力信号ラインはできるだけツイストペア線を使用してください。

内部電源使用のとき EX24V/EXCOMに接続
(in case of using internal power supply)
not recommend!!

< Case 2 > FTB

7-3-5 フロントターミナル・ブロック (FTB) 方式

FTB方式では、フィールドからの入出力配線を入出力モジュール前面の入出力端子に直接接続します。

- FTBの入出力ワイヤは0.3～0.75mm²をお薦めします。
- FTBは端子カバーに1～38の番号が、また端子ブロックには(A0～A18)、(B0～B18)が表示されています。本書では1～38の番号を使って入出力の接続を示します。また、各々の入出力I/Oケーブルについて信号とピン番号の関係を添付します。



図 7-44

注1) 配線上のコモン端子は入出力の種類によって8点、または16点単位に1端子が設けられていますので、中継端子盤などでの入出力コモン線のまとめが必要となります。

注2) 各種入出力（発信器、DO負荷など）用の電源ヒューズは必要に応じ外部で用意してください。

< Case 2 > FTB.

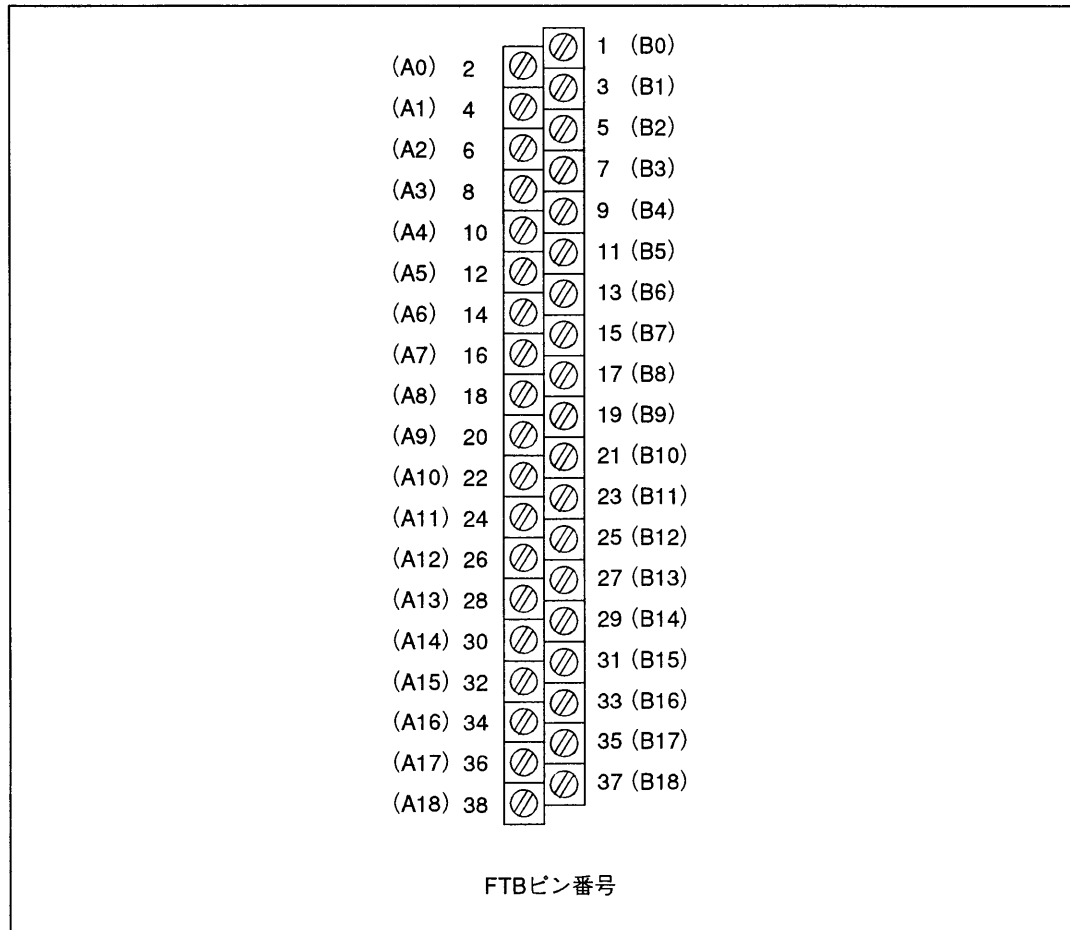
(5) パルス入力 (J-PIF00 使用時)

外部電源または内部電源の使用による2種類の接続方法があります。

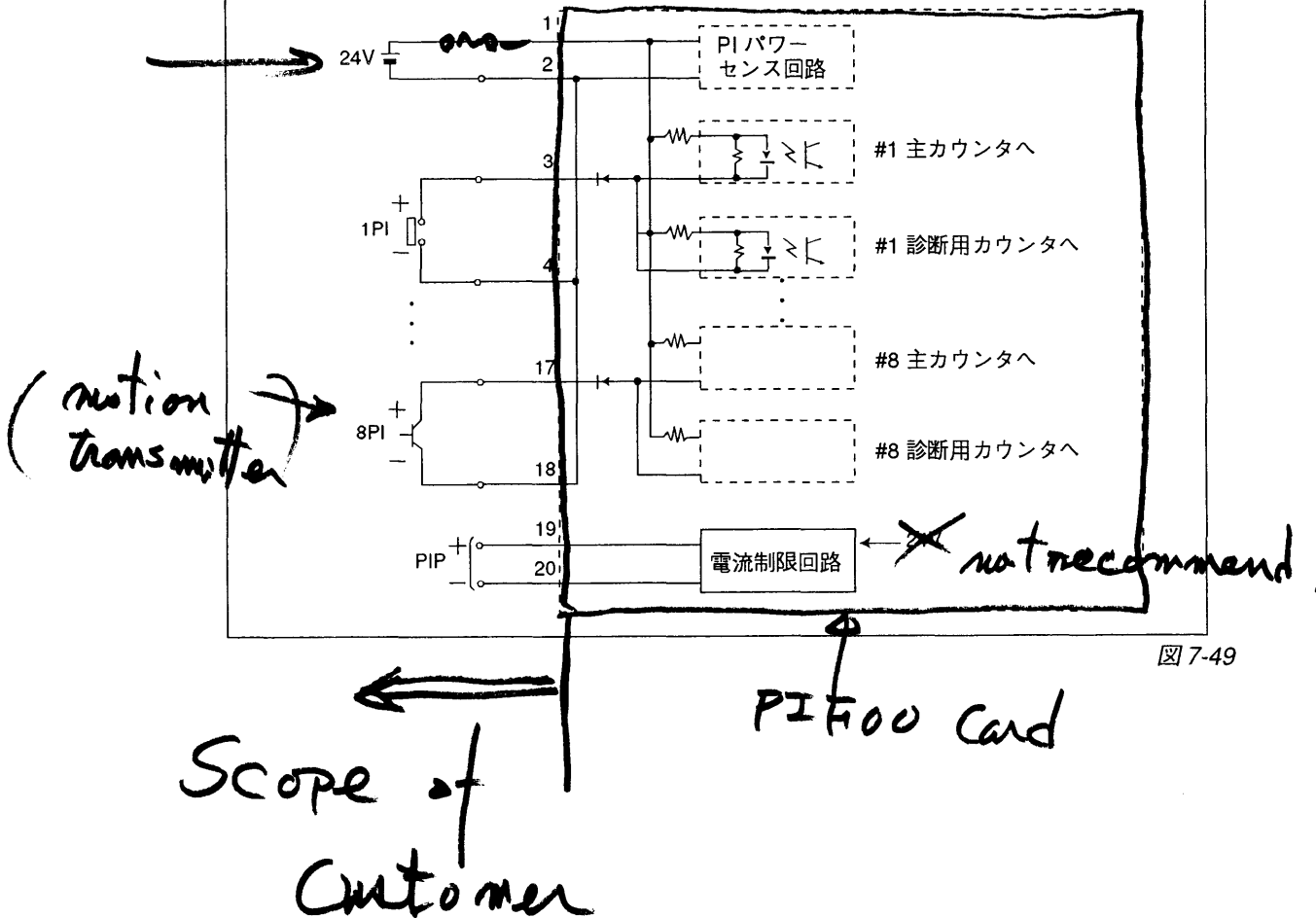
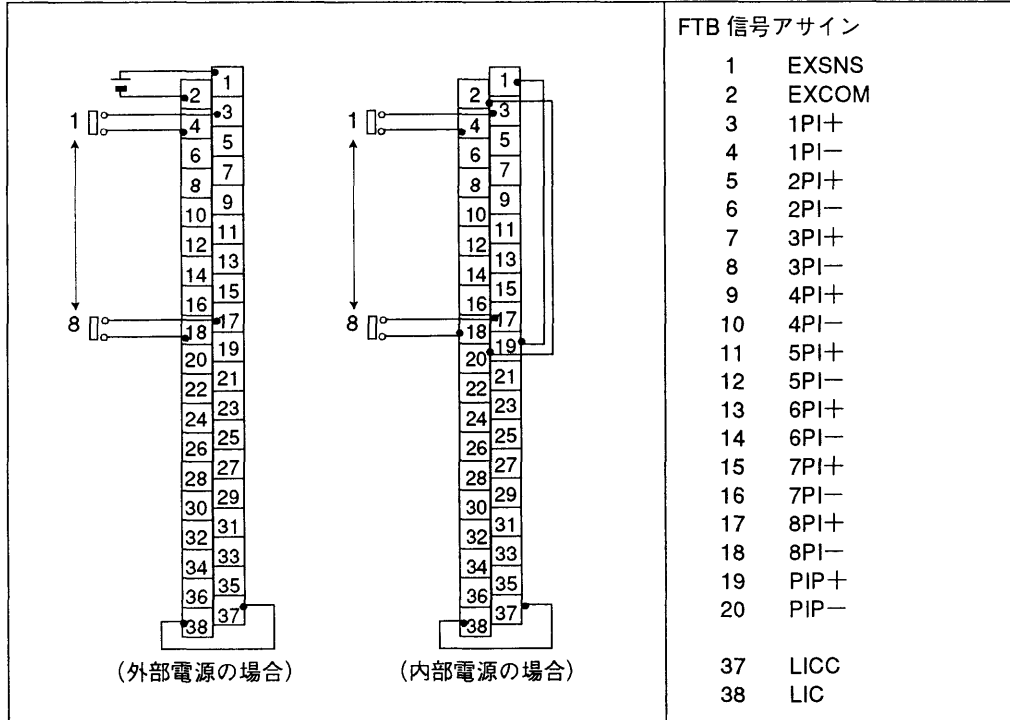

図 7-49