

### 5.3 Ink Injection

1. Cut off the swelled end of the ink container using a razor or a nipper.

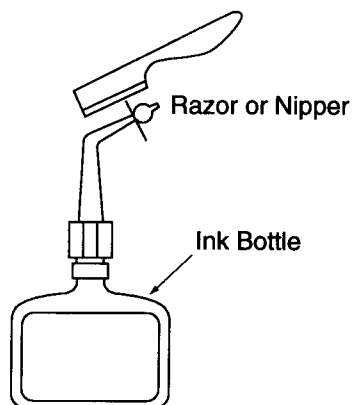


Figure 5-11. Ink Bottle

2. Connect the injection needle to the end of the ink bottle. Use the injection needle of the same color with that of ink used. (See Table 1.)

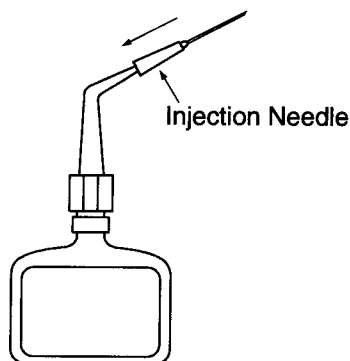
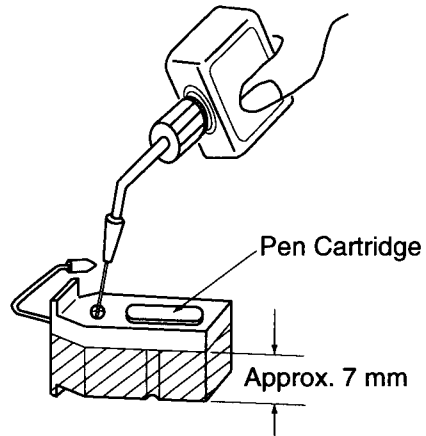


Figure 5-12. Setting the Injection Needle on the Ink Bottle

Table 1. Parts Nos. for Ink Injection

Color	Ink	Injection needle	Pen cartridge assembly
Blue	80041692-023	80279772-001	80279596-001
Red	80041692-021	80279772-002	80279596-002
Green	80041692-025	80279772-003	80279596-003

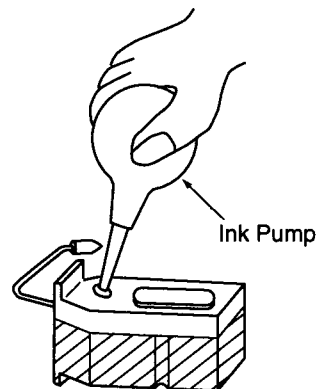
3. Inject ink into pen cartridge from its top, to a level of approximately 7 mm from the empty level (approximately 1.2 c.c.).
- 



**Figure 5-13. Injecting Ink into Cartridge**

---

4. To feed ink to the pend tip, use the ink pump.
- 



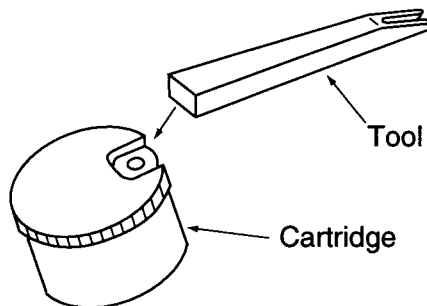
**Figure 5-14. Feeding Ink to the Pend Tip Using Ink Pump**

---

## 5.4 Installing the Fiber Tip

---

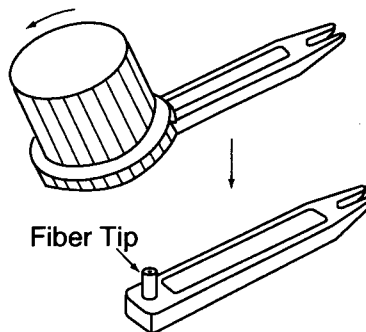
1. Take out the cartridge and tool from the fiber tip kit. Insert the tool in the slot of the cartridge.
- 



**Figure 5-15. Fiber Tip Kit**

---

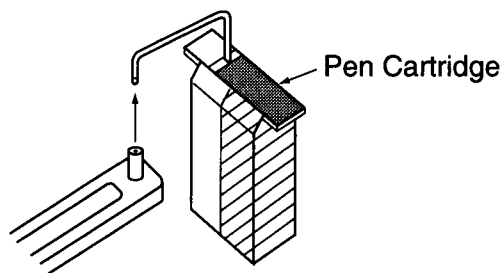
2. Turnover the cartridge and let a fiber tip fall into the hole of the tool.
- 



**Figure 5-16. Setting a Tip on the Tool**

---

3. Install the fiber tip on the pen cartridge assembly.
- 

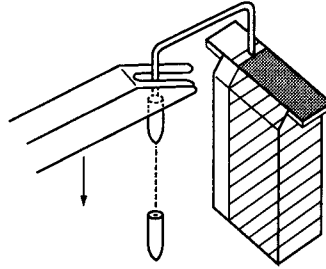


**Note:** When the width of the recorded trace has become wider than 0.5 mm, replace the fiber tip with a new one. When in the normal operating conditions, the fiber tip will serve for several months.

**Figure 5-17. Installing the Tip onto the Pen Cartridge**

---

4. To remove the fiber tip, use the other end of the tool. Set the tool on the fiber tip and pull it down.



**Figure 5-18. Removing the Tip from the Pen Cartridge**

---

## 5.5 Installing the Pen Cartridge

---

1. Turning the handle at the lower section of the scale with your finger, open the scale frontward.

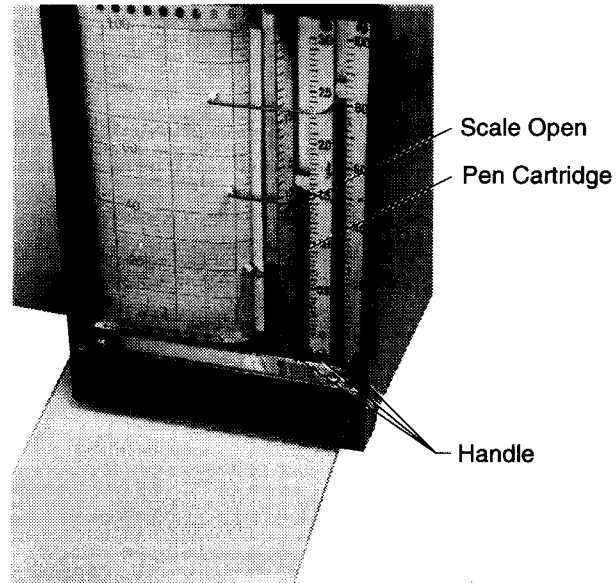


Figure 5-19. Pulling out the Scale

---

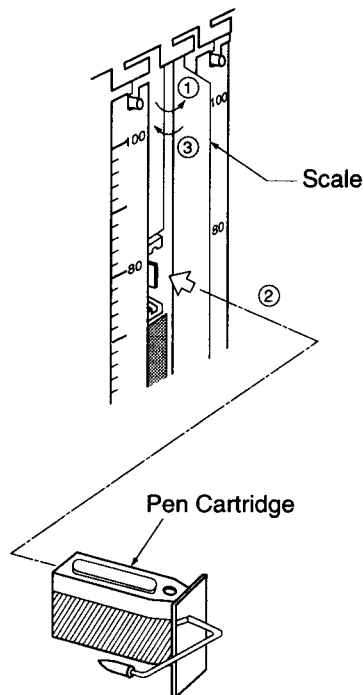


Figure 5-20. Inserting the Ink Cartridge

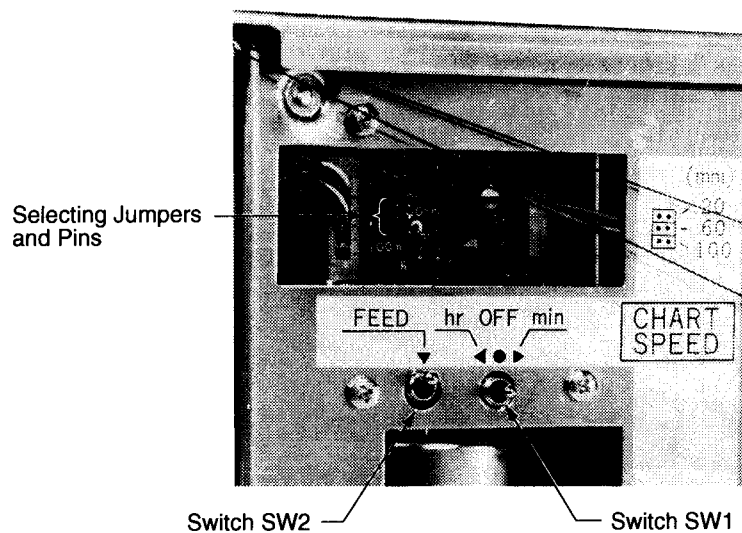
---

2. Insert the pen cartridge to the point where it is locked by the pen mechanism.
3. Close the scale by turning the handle with your finger.

To take out the pen cartridge

4. Open the scale frontward by turning the handle with your finger.
5. Pull out the pen cartridge frontward.

## 5.6 Selecting Chart Drive Speed



**Figure 5-21. Chart Drive Speed Selecting Mechanism**

The chart feed speed is selectable with the selecting jumpers. Insert the jumper socket onto the pins for 20, 60, or 100 mm, as required.

Switch SW1 is a 3 horizontal position toggle switch. The OFF position is for chart stop, the “hr” position for chart drive in the unit of hour, and the “min” position for chart drive in the unit of minute.

Switch SW2 is a 2 vertical position non-lock toggle switch. When it is depressed in the FEED direction and held in the depressed state (in the downward position), the chart is fed at a speed of 100 mm/minute irrespective of setting of SW1 selector jumper (except when SW1 is in the OFF state).

**MEMO**

---

✓

✓

✓

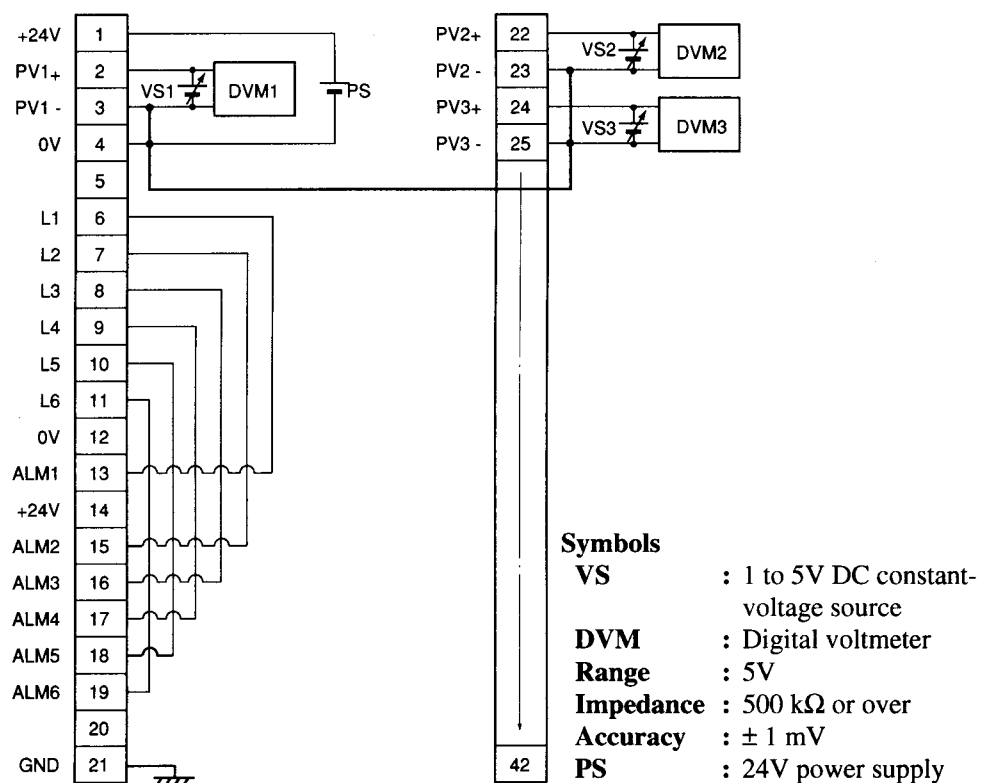
✓

✓

## Section 6. Adjustment and Calibration

### 6.1 Preparation

1. Prepare a test setup as shown in figure 6-1.
2. After turning on the instrument power, allow 15 minutes or more of stabilization time.



**Note:** 1. The monitor output can be made by jumpering terminals 6–19 as shown in the above.

2. If the instrument has a provision for ON/OFF-control of chart motor with an external control signal, connect an external contact signal between terminals 20 and 26. (Note that the chart may be broken if the pen is driven on the stationary chart.)

Figure 6-1. Test Setup

## 6.2 Adjustment and Calibration

1. Mechanical and electrical adjustments of the recorder are completed before shipping it from the factory. Check the accuracy of the recorder as described in Paragraph 6.2.2.
2. If the accuracy is insufficient, adjust the servo amplifier as explained in the following.

### 6.2.1 Servo Amplifier

The explanation in the following is for the case of No. 1 input. The same method applies to No. 2 input also.

1. Set the potentiometers as follows:

VR1: }  
 VR2: } In a midposition of total adjusting angle

VR3: }  
 VR4: } At fully clockwise position  
 VR5: }

VR6: At fully counterclockwise position

2. Connect the constant-voltage source (VS1) and digital voltmeter (DVM1) to the recorder.

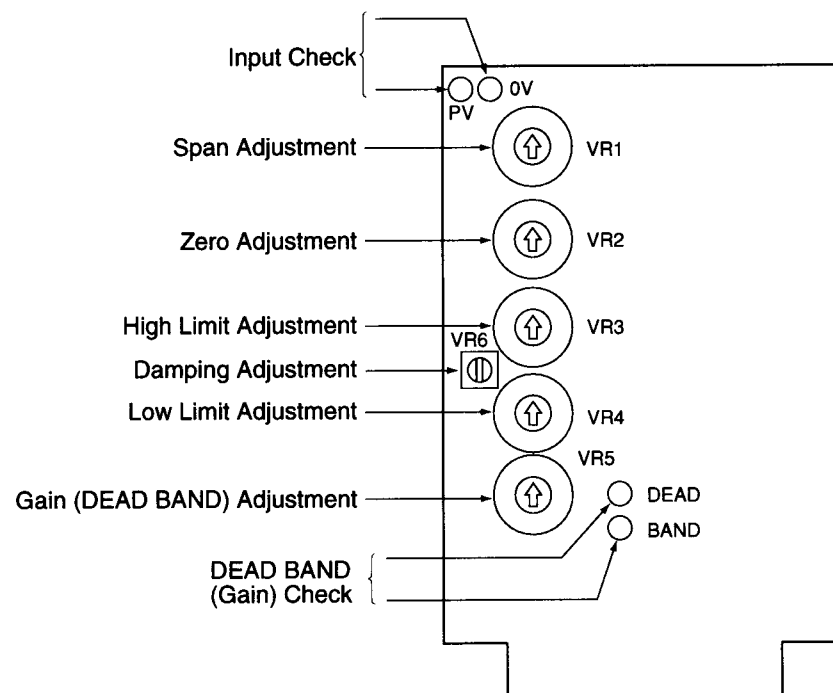


Figure 6-2. Adjustments and Check Points on Servo Amplifier PC Board

3. Set VS1 at 3.000V on DVM1. Turn VR5 to a point immediately before the point where the instrument starts hunting. Check that the voltage between the DEAD BAND check terminals is approximately 5 to 8mV. If the instrument does not start hunting even when VR5 is turned to the fully counterclockwise position and the dead band is not greater than 0.3%, no further adjustment of dead band is needed. (Dead band adjustment)
4. Set VS1 at 1.000V on DVM1. Adjust VR2 so that the indication becomes 0%. (Zero adjustment)
5. Set VS1 at 5.000V on VM1. Adjust VR3 so that the indication becomes 100%. (Span adjustment)
6. Setting VS1 at 0%, 25%, 50%, 75% and 100%, check that accuracy is within +0.5% FS at each of these check points.
7. Turn VR3 and VR4 to the fully counterclockwise position.
8. Set VS1 at 0V on DVM1. Adjust VR4 so that indication is between 0% and mechanical stopper. (Low limit adjustment)
9. Set VS1 at 6V on DVM1. Adjust VR3 so that indication is between 100% and mechanical stopper. (High limit adjustment)
10. By turning VR6 clockwise, time constant can be adjusted to 660 m sec maximum. Set time constant at an appropriate value depending on the rate of change of the input signal. (Damping adjustment)

### **6.2.2 Internal Monitor Switches**

To remove the monitor switches, remove the clamping screws and then pull out the unit.

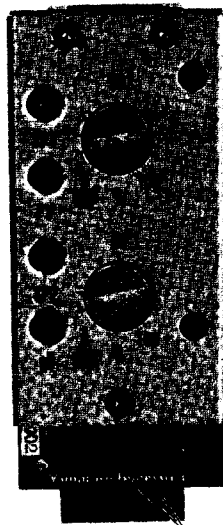
1. Set the SPAN ADJ potentiometer, VR1 (VR2), at a midposition of its total adjusting angle.
2. Set the PV input at 1V. Turn the monitor setting dial until the transistor output of the monitor switch is switched. In this case, adjust the mechanical position relationship between the setting dial and the shaft of the setting potentiometer, VR3 (VR4), so that the met point of the monitor becomes 0%.
3. Set the PV input at 5V. Adjust the SPAN ADJ potentiometer, VR1 (VR2), so that the transistor output of the monitor switch is switched at 5V.

4. Repeat steps (b) and (c) alternately until the setting accuracy of the monitor scale becomes  $\pm 0.2V$  ( $\pm 5\%$  FS) in input equivalent value.
5. Remove the three clamping-screws of the monitor witch. Change connections of jumper wires so that the required modes of operation are obtained, referring to the following table.

Alarm	Status of output when in alarm	Connections of jumper wires		
		1-point monitor	2-point monitor	
		ALM1	ALM1	ALM2
High limit alarm	ON	A-B	A-B	E-F
		C-D	C-D	G-H
	OFF	A'-B'	A'-B'	E'-F'
		C'-D'	C'-D'	G'-H'
Low limit alarm	ON	A'-B'	A'-B'	E'-F'
		C'-D'	C'-D'	G'-H'
	OFF	A-B	A-B	E-F
		C-D	C-D	G-H

**Example 1:** When a 2-point monitor is used, the output is to be ON when in the alarm state, and the high limits are to be monitored for both ALM1 and ALM2, connect the jumper wires as follows: (A-B, C-D), (E-F, G-H).

**2:** When a 2-point monitor is sued, the output is to be ON when in the alarm state, and the high limit of ALM1 and the low limit of ALM2 are to be monitored, connect the jumper wires as follows: (A-B, C-D), (E'-F', G'-H').



Monitored Item Selecting Jumper Wires

Figure 6-3. Monitor Switch PC Board

---

## **Section 7. Maintenance**

---

### **7.1 Routine Maintenance**

---

#### **■ Recording Chart Paper**

1. A red band will appear at a point of 600 mm before the end of the chart.
2. For chart paper replacement, refer to Section 5.2.
3. When chart paper has become slack, tighten it by pressing the FEED switch referring to Section 5.7.

#### **■ Recording Mechanism**

1. For replacement of the ink cartridge, see Section 5.5.
2. For replacement of the fiber tip, see Section 5.4.
3. For recording ink, see Section 5.3.

---

### **7.2 Replacement of Parts**

---

#### **7.2.1 Bezel and Door**

To replace the bezel and door, remove the rubber magnet and five screws of the bezel.

#### **7.2.2 Chart Drive Mechanism**

Refer to Section 5.2.

### 7.2.3 Drive Cable

#### ■ Removing the Drive Cable

Disengage the spring of the drive cable assembly and remove the cable from the stud.

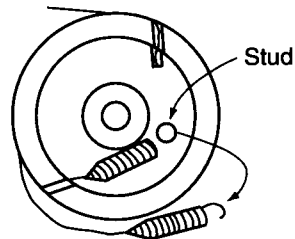


Figure 7-1. Removing the Cable from the Stud

#### ■ Threading the Drive Cable

1. Thread the drive cable assembly (Parts No. 80279602-ITEM) in the order of 001, 002 and 003. If it is threaded in the reverse order, cables will cross.

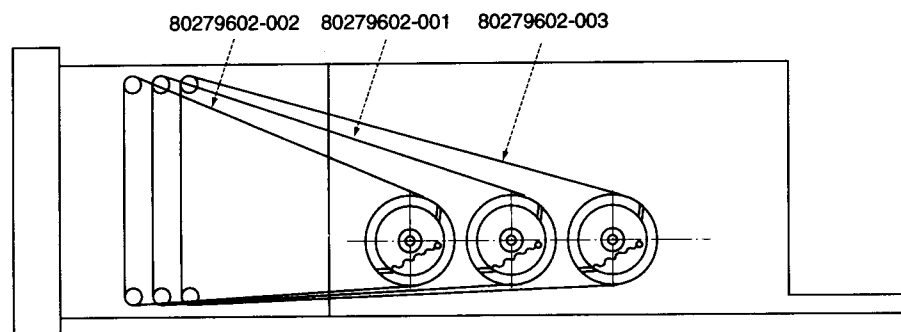
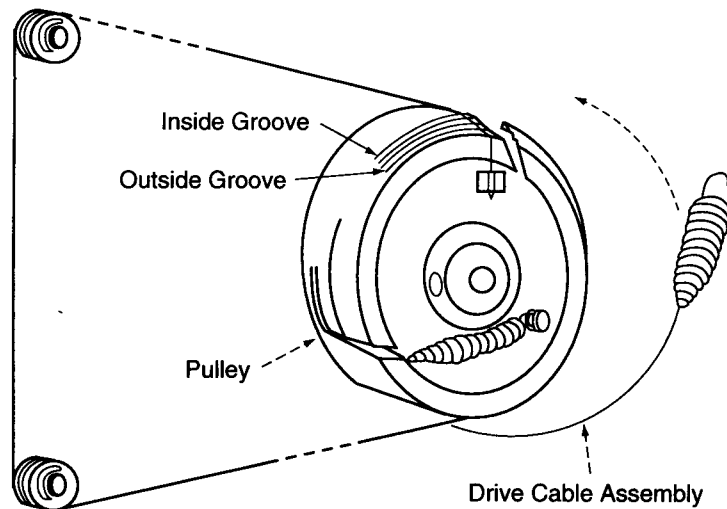


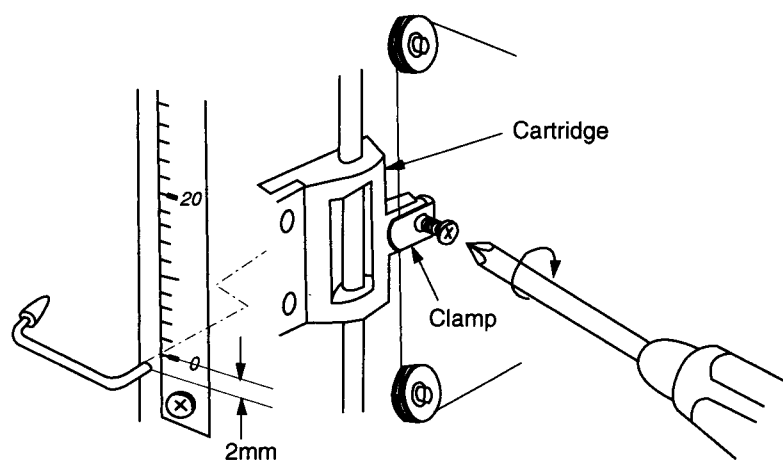
Figure 7-2. Threading the Drive Cable

2. Insert the pressed sleeve in the inside groove and the spring in the outside slot, and pull the drive cable assembly.

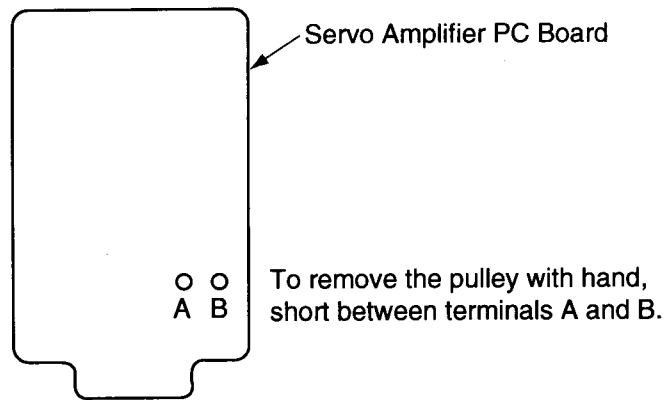


**Figure 7-3. Threading the Drive Cable (2)**

3. Lock the clamp plate as follows:
  - a. Turn the pulley clockwise until it is stopped by the stopper.
  - b. Let the cartridge assembly positioned always at the bottom (approximately 2 mm lower than the zero scale position).
  - c. Lock the clamp plate with the lock screw.



**Figure 7-4. Fixing the Drive Cable and Cartridge**



*Notes: When terminals A and B on the servo amplifier PC board is shorted, the pen cartridge can be moved by moving the pulley with your hand. Moving the pen on the scale for the range from 0 to 100%, adjust the pen position and recording position with respect to the mechanical topers. After the adjust is over, remove the shorting wire from terminals A and B.*

**Figure 7-5. Servo Amplifier PC Board**

---

#### **7.2.4 Pen assembly**

1. Remove the bezel and the drive cable.
2. Remove the three fixing-screws of the pen assembly.

### 7.2.5 Tape Assembly

1. Remove the pen assembly.
2. Remove the spring and E-clip. Pull out the cartridge assembly.
3. Remove the tape assembly from the cartridge assembly.
4. Replace the tape assembly with a new one. Fix it by following in the reverse order the procedure of (1) to (3) above.

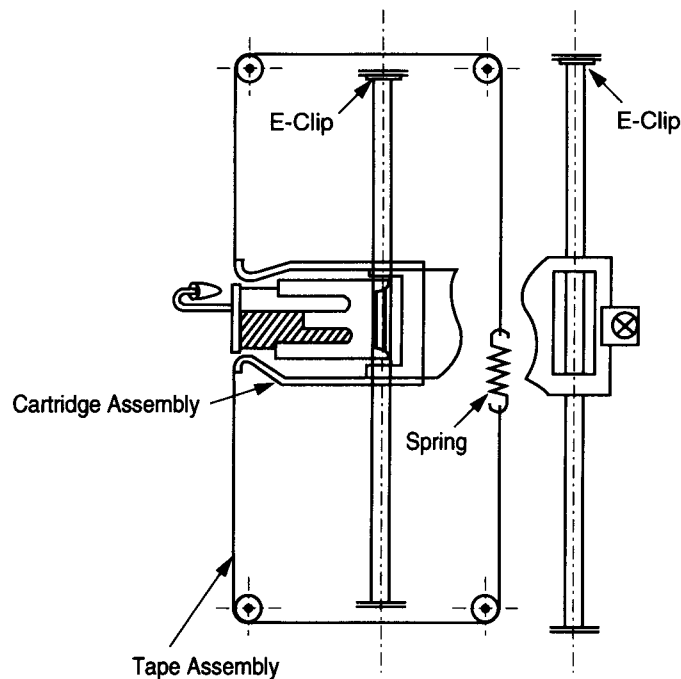


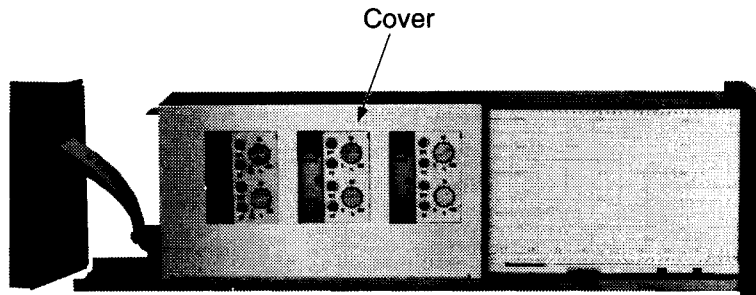
Figure 7-6. Tape Assembly

### 7.2.6 Chart Motor Assembly

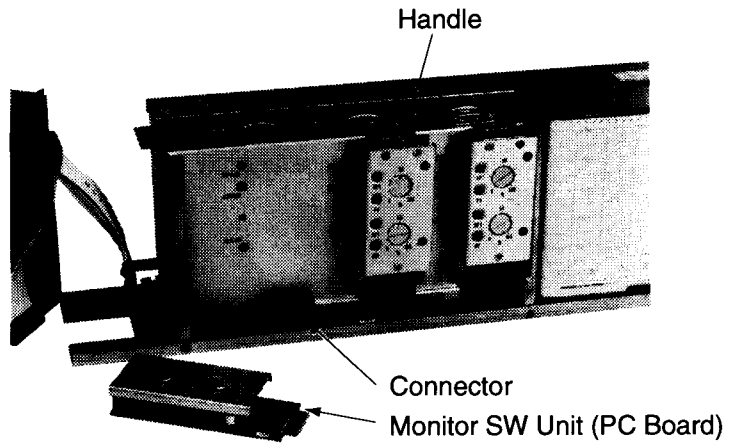
1. The chart motor assembly has been correctly connected and adjusted to the chart feed motor assembly. When replacing the chart motor, do not remove the screws.
2. Remove the chart drive assembly.
3. Remove the two fixing-screws of the chart motor using a short-stud screwdriver. In this case, be sure not to remove the screws of the chart motor assembly.
4. Replace the chart motor with a new one. Fix it by following in the reverse order the procedure of (1) and (2) above.

### 7.2.7 Monitor Switch

1. Remove the cover.
2. Holding the handle with your hand, pull out the monitor switch PC board.



**Figure 7-7-1. Left-hand View of the Chassis**



**Figure 7-7-2. Removing the Monitor Switch PC Board**

### 7.2.8 Servo Amplifier PC Board

1. Remove the cover.
2. Disconnect the 3P and 5P connectors from the pulse motor and potentiometer, respectively.
3. Holding the handle with your hand, pull out the amplifier.

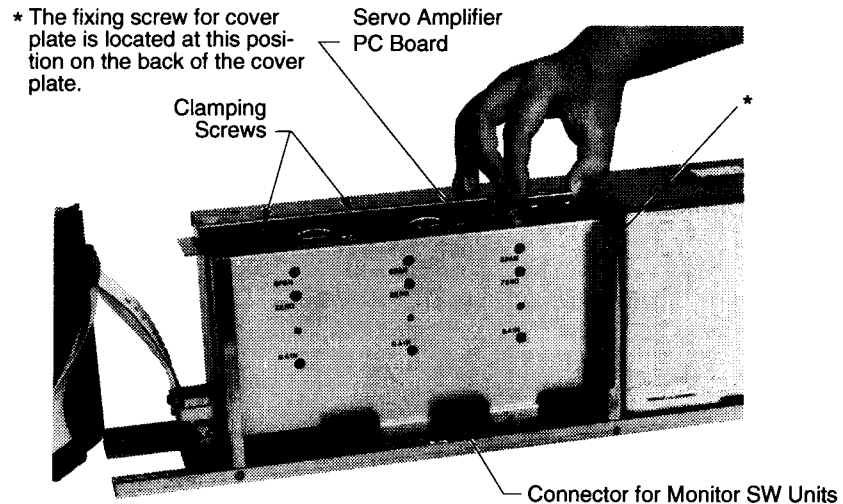


Figure 7-8. Servo Amplifier PC Board

### 7.2.9 Servo Unit

1. Remove the cover and the drive cable.
2. Remove the monitor switch PC board.
3. Remove the servo amplifier PC board.
4. Remove the fixing screws (two) of the amplifier cover and pull out the servo amplifier PC board.
5. Remove the three fixing-screws of the servo unit.

### 7.2.10 Pulse Motor

1. Remove the servo unit.
2. Remove the two fixing-screws of the pulse motor.
3. Install the pulse motor and fix it by following in the reverse order the procedure of (1) and (2) above.

### 7.2.11 Potentiometer

1. Remove the servo unit.
2. Undo the setscrews of the pulley assembly. Remove the pulley assembly.
3. Remove the two fixing-screws of the potentiometer.
4. Instal the potentiometer and fix it by following the above procedure in the reverse order.
5. Install and adjust the pulley  
After the above adjustment is over, adjust the pulley so that its surface becomes flush with the end surface of the potentiometer shaft and fix the setscrews in this state.

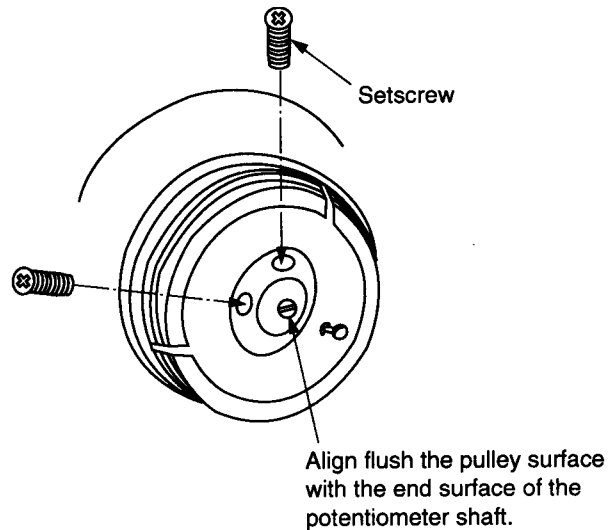


Figure 7-9. Installing the Pulley

### 7.2.12 Chart Drive PC Board

1. Remove the cover
2. Disconnect the connector (3P) of the mother board.
3. Open the chart cartridge, and remove the two mounting-screws on the side of the recorder.






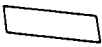




**7.2.13 Main Connector Board**

1. Remove the connector bracket.
2. Remove the cover.
3. Remove the servo amplifier PC board and servo unit.
4. Undo the three fixing-screws of the main connector board.

**7.2.14 Life Expectancy of Components**

Parts Name	Parts No.	Longevity	Remarks
Servo unit ass'y	80330547-001	5 years	
Chart motor unit ass'y	80330538-002	5 years	
Fiber tip	80279758-001	3 months	When linear trace is written with chart speed of 20 mm/hour
Ink	80041692-ITEM	3 months	250 meters or more with 1.2 cc of ink
Chart	80279578-001	1 month	15 meters long
Drive cable	80279602-ITEM	5 years	
Color tape	80279670-ITEM	5 years	
Pen cartridge		—	Wash with fresh water once a year. (Wash also when the recorder has not been operated for a prolonged period of time.)

**Table of Accessories**

Accessory		Quantity			Parts No.
		KSR100	KSR200	KSR300	
	Mounting bracket	1	1	1	80233916-001
	Chart	1	1	1	80279578-001
	Chart bobbin	1	1	1	80279579-001
	Fiber tip kit	1	1	1	80279758-001
	Ink pump	1	1	1	80234103-001
	Name plate	1	1	1	80330596-001
	Ink, red, 30 cc Ink, blue, 30 cc Ink, green, 30 cc	1 — —	1 1 —	1 1 1	80041692-021 80041692-023 80041692-025
	Injection needle, red Injection needle, blue Injection needle, green	1 — —	1 1 —	1 1 1	80279772-002 80279772-001 80279772-003
	Pen cartridge, for Pen No. 1 Pen cartridge, for Pen No. 2 Pen cartridge, for Pen No. 3	1 — —	1 1 —	1 1 1	80279752-002* 80279752-001* 80279752-003*
	Pen marker, red Pen marker, blue Pen marker, green	1 — —	1 1 —	1 1 1	80279756-002* 80279756-001* 80279756-003*

\* : We do not sell pen cartridge and pen marker by each. Pen cartridge, pen marker and fiber tip are combined with pen cartridge assembly. In place of the above parts number, refer to the following numbers.

Pen cartridge assembly for No.1 Pen: 80279596-002

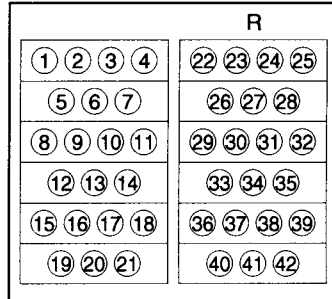
Pen cartridge assembly for No.2 Pen: 80279596-001

Pen cartridge assembly for No.3 Pen: 90279596-003

## 7.3 Reference Drawings

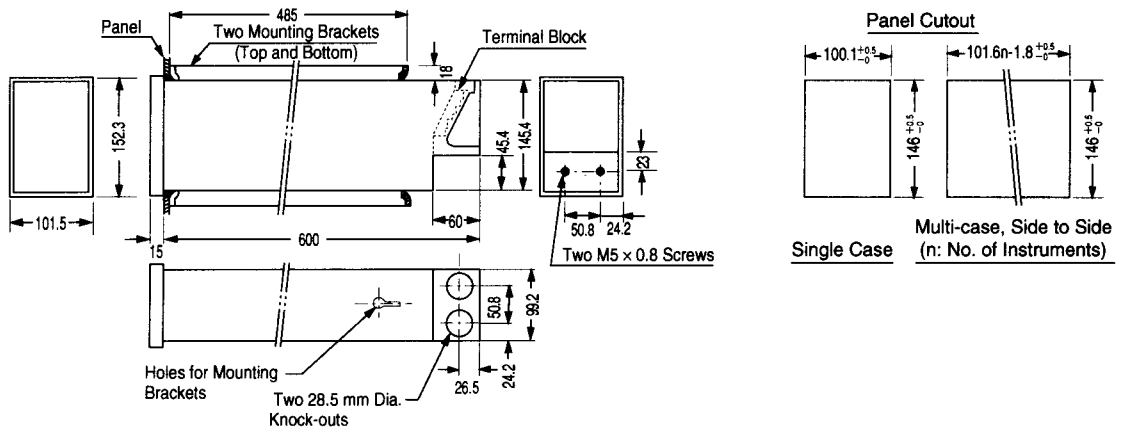
### Customer Terminal Connections

Customer Terminals



No.	Symbol	Contents	No.	Symbol	Contents
1	+24V	DC24V power supply +	20	CH. M. SW	Chart motor switch
2	PV1 +	Process variable 1 +	21	GND	Chassis ground
3	PV1 -	Process variable 1 -	22	PV2 +	Process variable 2 +
4	0V	Power common	23	PV2 -	Process variable 2 -
5	—	—	24	PV3 +	Process variable 3 +
6	AL1	Lamp power supply 1	25	PV3 -	Process variable 3 -
7	AH1	Lamp power supply 2	26	CH. M. SW	Chart motor switch
8	AL2	Lamp power supply 1	27	PV1 I/V +	Process variable (current) 1 +
9	AH2	Lamp power supply 2	28	PV1 I/V -	Process variable (current) 1 -
10	AL3	Lamp power supply 1	29	PV2 I/V +	Process variable (current) 2 +
11	AH3	Lamp power supply 2	30	PV2 I/V -	Process variable (current) 2 -
12	0V	Power common	31	PV3 I/V +	Process variable (current) 3 +
13	PV1. ALM1	PV1. Alarm contact 1 +	32	PV3 I/V -	Process variable (current) 3 -
14	+24V	DC24V power supply +	33	0V	Signal common
15	PV1. ALM2	PV1. Alarm contact 2 +	34	0V	Signal common
16	PV2. ALM1	PV2. Alarm contact 1 +	35	0V	Signal common
17	PV2. ALM2	PV2. Alarm contact 2 +	36	—	—
18	PV3. ALM1	PV3. Alarm contact 1 +	37	—	—
19	PV3. ALM2	PV3. Alarm contact 2 +	38	—	—
			39	—	—
			40	—	—
			41	—	—
			42	—	—

### External Dimensions



# MEMO

---

---

**Document Number:** OM2-3220-0880

**Document Name:** NutroniK8000  
Recorder  
Operator's Manual (Model KSR110/210/310)

---

**Date:** September, 1982  
July, 1998 (Rev.5)

**Publisher:** Yamatake Corporation

**Edit:** Yamatake Industrial Systems Co.,Ltd.

---

# Yamatake Corporation